

# Power Supply Testing with the 5180A Waveform Recorder

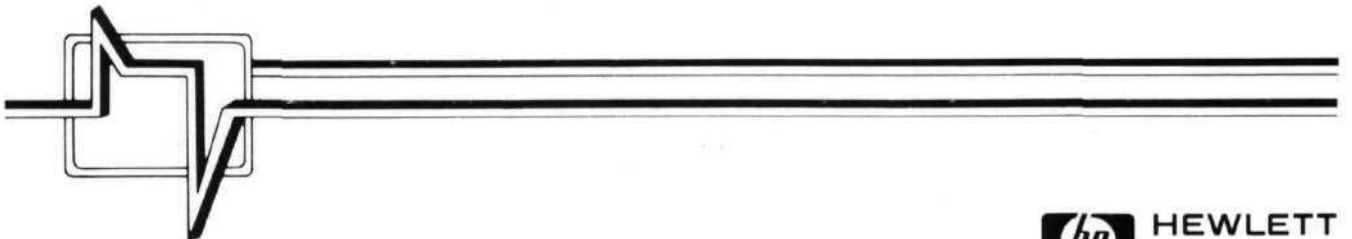

## INTRODUCTION

Traditional power supply tests include capturing transients for turn-on, turn-off, and step load recovery. Similar tests are performed during power supply design. In either case, the measurement problem is the same: A single shot must be captured and represented in useful form.

The degree of accuracy and resolution in the result as well as convenience in processing are also part of the measurement problem.

The transient signal, whether it comes from a power supply test or other measurement has usually been difficult to analyze. Recent advances in signal capturing technology, however, provide methods for acquiring and analyzing these events. The waveform recorder, a digital capturing instrument employing a high speed analog-to-digital converter and memory, can capture even the most elusive power supply test signal. The features of the HP 5180A Waveform Recorder make it an ideal measurement tool in power supply testing. Since data is captured and stored in digital form, viewing and analyzing transient events are simplified: specify a precise trigger level and position the viewing window anywhere along the transient, seeing as much of the pre-trigger baseline as needed. Read rise times and important voltage information by positioning measurement cursors. Expand the waveform in time with zoom or vertically with gain to see fine detail. Then, after the desired measurement is taken, transfer the data to a computer for processing. This note describes several well known power supply tests and shows how the 5180A is applied to simplify the measurements. Also, some useful data processing techniques are suggested.

## BACKGROUND

Transient performance of a loaded or unloaded supply during turn-on, turn-off, or step load is usually measured repetitively with a conventional scope or single shot with a storage scope. Both methods provide limited information to the design or test engineer. Rise time can't be accurately measured unless pre-trigger baseline information is displayed. There may be some pre-trigger interference (EMI) that goes unnoticed especially if the scope and power supply are triggered simultaneously. Repetitive techniques have been employed, but measurements performed this way may indicate a steady state response where a transient response is expected. Some measurements just aren't easy to perform repetitively, like a turn-off transient for an unloaded supply, where fall times may reach several seconds. Perhaps the most significant drawback is the limitation in signal processing – full automation isn't possible because oscilloscope data can't be easily manipulated.

### Waveform Recording

A waveform recorder offers improvement in three performance areas: triggering, resolution, and digital processing.

#### Triggering

The high speed memory system used in the 5180A permits viewing waveforms before or after the trigger event. When the recorder is armed and waiting for trigger, the ADC begins converting the input signal and outputting to a "wrap around" memory (think of an endless tape loop). When trigger occurs, the recording continues until a specified number of convert/write cycles are completed. The trigger position determines how much base line information is included in the data.

The high speed memory size of the 5180A is 16K x 10 bits (each word is 10 bits wide). The memory may be segmented into as many as 32 blocks, with a minimum size of 512 points. In pre-trigger recording, up to 100% of the memory block may contain data before the trigger (the *last* point displayed is the trigger point). Pre-trigger may be specified in either absolute time or percent of the record length.

Post-trigger recording places a precise, digitally controlled delay between the trigger event and data recording. (a 0% post-trigger means that the *first* point displayed is the trigger point; the same representation given by a scope). Delays from 50 nsec to several hours may be specified either in absolute time or percent of the record length.

#### Resolution

Improved resolution offered by a waveform recorder means that signal differences, previously going unnoticed, may be seen and measured. The 5180A's 10 bit ADC allows measuring voltages with about 0.1% resolution. Input frequencies may extend to 10 MHz (the Nyquist Frequency). Moveable cursors may be positioned anywhere along the captured waveform. Transients of unknown amplitude are easily measured by placing the cursor on the peak sample of the event. Time resolution is improved because the location of a sample point is precisely controlled by the conversion clock. The same cursors used to measure voltage are used to measure time.

## Digital Processing

Frequently it is necessary to capture and process analog data or save data permanently on tape. For example, it may be necessary to multiply two measurements, one current and one voltage, to obtain instantaneous power. Triggered photographic techniques, tediously implemented with a storage scope and camera, have been used to manually digitize transient events. The process is exhausting and often suffers from inadequate time and voltage resolution. A waveform recorder simplifies the task of retrieving and processing recorded data. Flexible data output schemes allow interfacing with a variety of processors; from simple desktop controllers to powerful scientific computers. In the 5180A, digital outputs include HP-IB and a powerful DMA port having a data transfer rate of 1 million data words per second. Processed data may also be input to the 5180A high speed memory, allowing complete measurement I/O capability.

## MEASUREMENTS:

### TURN-ON, TURN-OFF, AND STEP LOAD RECOVERY

Three typical performance measures for power supplies, turn-on, turn-off and step load recovery, were investigated using the 5180A 20 MHz, 10-bit waveform recorder. Generally accepted power supply testing rules were applied using standard term definitions and loading.

#### Turn-on and Turn-Off Events

Design and test engineers are interested in turn-on and turn-off performance. In design, it's necessary to measure rise times, fall times, and overshoot to evaluate the performance of regulators and protective circuitry. Test engineers want to monitor these tests for continuing effectiveness in each production run.

#### Turn-On Testing

A 5180A was used to capture the turn-on event for a loaded and unloaded supply. A 4096 point record length was chosen, although as few as 512 or as many as 16K samples could have been specified. What's most important is the time window covered (determined by a sample frequency of at least twice the highest input frequency and a sufficient number of points). The exact time window is simply the record length multiplied by the main timebase setting in time-per-point. A 5180A display gives the time window in seconds.

A 5 volt bench supply was loaded to rated output (one amp) using a 5 ohm resistor. The signal was input to the 5180A's A channel, one of two 1M ohm input channels with attenuation factors from  $\pm 0.1V$  to  $\pm 10V$  full scale. The  $\pm 5V$  range was used with a  $-0.25V$  input offset to capture the transients while allowing for possible overshoot.

Figure 1 shows the output turn-on transient at rated load. The intensified dot is the trigger point (placed in this measurement at  $-20\%$  to give the necessary pre-trigger baseline). The trigger level was chosen to be  $0.90V$ . Sample speed was  $50 \mu\text{sec}$  per point, giving a sweep time window of  $204.8 \text{ msec}$ .

Two cursors were used to measure to the turn-on time (0% to 100%). The time difference between cursors was  $106.4 \text{ msec}$  (read directly from a front panel display). Absolute voltage difference between the cursors was  $5.1V$ . With the 5180A, single and dual cursor modes may be used to make absolute or relative time and voltage measurements.

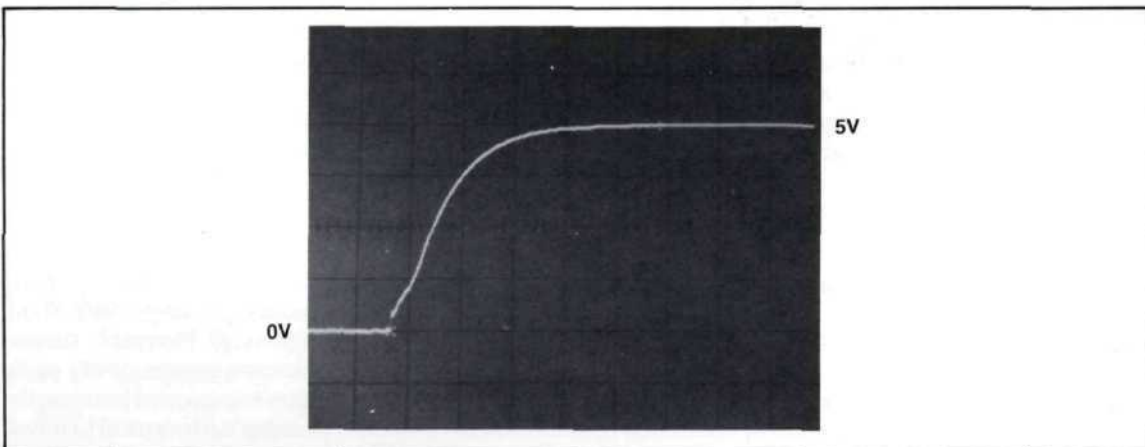
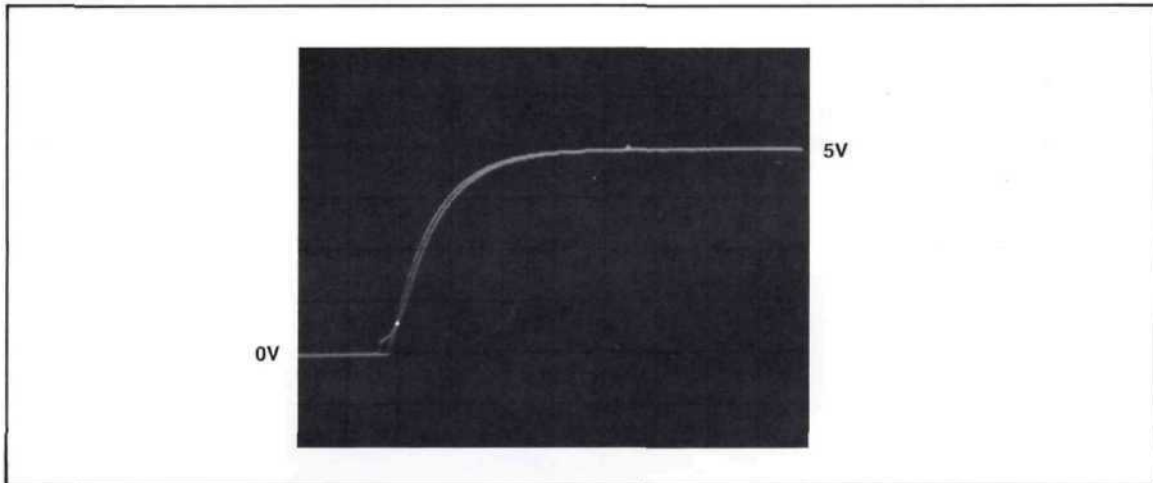

Figure 1. Turn-on transient, rated load. Two cursors measure rise time of  $106.4 \text{ msec}$ .

The unloaded turn-on transient resulted in a much slower rise time (Figure 2a). The 5180A's dual trace mode was used to display both the loaded and unloaded waveforms simultaneously. The waveform first to rise was that of the loaded turn-on.

For more detail, the two waveforms were expanded using horizontal zoom and vertical gain (Figure 2b). The display's horizontal sweep now shows 256 consecutive data points of the original 4096 point record, giving a time window of 12.8 msec. The time difference between the two cursors is 2.025 msec. Vertical gain has been increased from 5V to 0.64V full scale. A base line offset difference of 90mV was due to residual charge in the filter capacitor.



**Figure 2a.** Loaded and unloaded turn-on displayed using dual trace. The loaded response is first to rise.

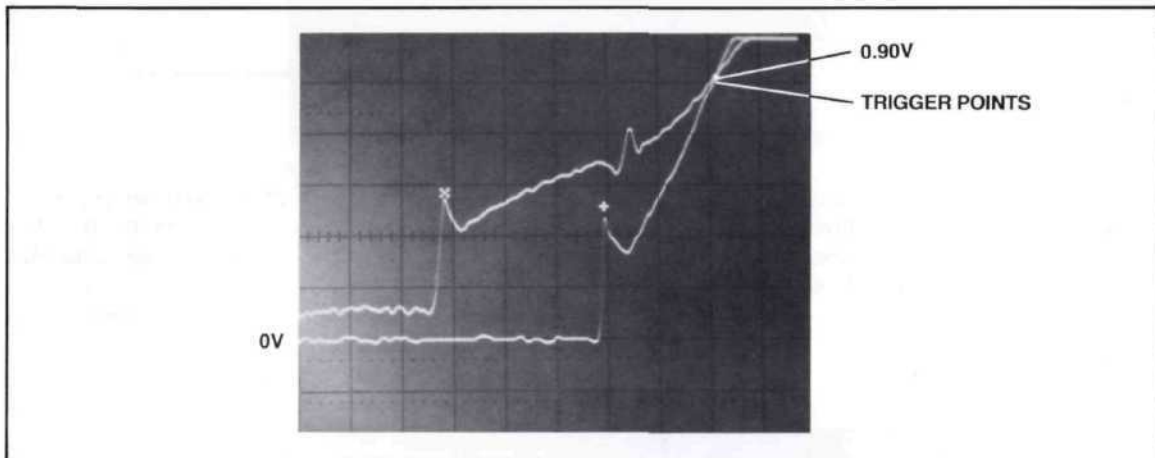

**Figure 2b.** Vertical and horizontal expansion of the turn-on transients shown in 2a. Each waveform covers 256 consecutive points of the original 4096 point records.

The intensified dots in Figure 2b represent the two trigger points. The exact alignment of the two trigger points is made possible by the repeatability of the 5180A's internal digital trigger. Both trigger level and hysteresis are implemented using an internal digital comparison between instantaneous ADC output code and a voltage entered from the front panel. Reliable and repeatable trigger is absolutely necessary for comparing two independently captured events.

### **Controlling Turn-on Performance**

Switching regulators are prone to damage at turn-on or turn-off because of voltage sensing in the feedback loop. During turn-on, for example, the feedback loop's error amplifier senses low output and tries to raise the output by driving the switching transistor to a 100% duty cycle. A capacitor is usually placed at the reference input of the error amplifier to force a minimum duty cycle during turn-on. Transistor "on time" is slowly increased preventing "run away" modulation of the switcher. The effectiveness of the protective circuitry can best be measured by inspecting signals within the switching regulator.

A simplified schematic for the switching supply under investigation is shown in Figure 3. The circuit employs an error amplifier/modulator device to provide base current pulses to Q1, the series pass element.

The base signal is a 28 KHz modulated duty cycle pulse wave. The width of the current pulses controls the on time for Q1 and in turn, the power supply output voltage. The inductor L1 and capacitor C1 filter the emitter current pulses, resulting in the regulated 5V output.

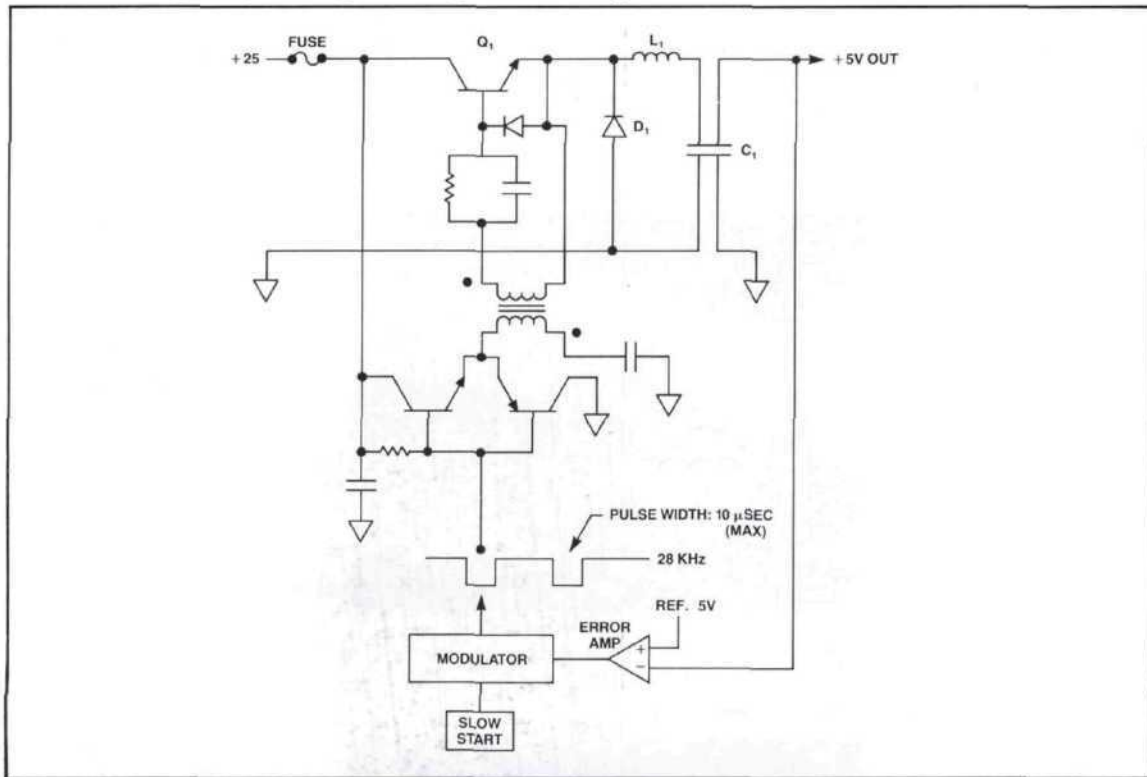

Figure 3. 5V Switching Regulator

An active current probe was used to measure the emitter current. The 5180A was set to sample at 50 nsec/point with a record length of 4096 points. Figure 4 shows the captured emitter waveshape under steady state rated load conditions. The pulse width was 10.8 μsec and the period was 36 μsec. The peak current was 11.04 amps. Remember, the pulse width becomes wider as load current increases and narrower as load current decreases. Important features of the emitter current pulse are presented in Figure 5.

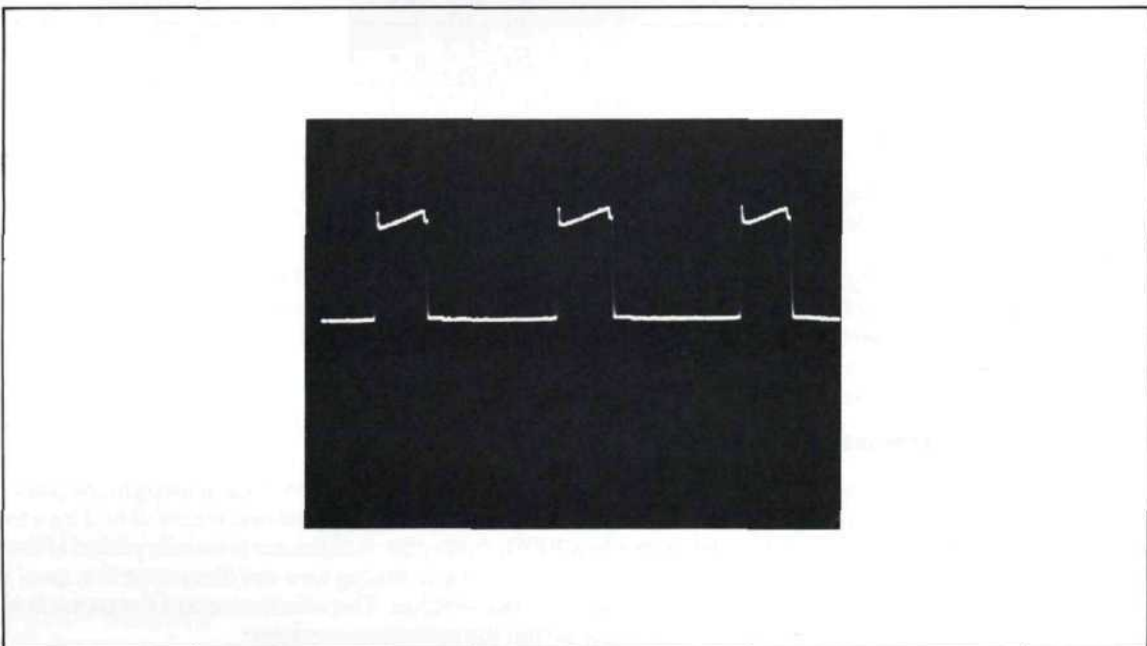

Figure 4. Emitter current pulses for steady state rated load. Pulse width is 10.8 μsec and pulse period is 36 μsec.

The slow start circuitry (shown in Figure 3) holds the transistor's duty cycle and amplitude to a minimum at turn-on. This action was tested by observing the emitter voltage at the instant of turn-on (emitter current and voltage have similar waveshapes). The 5180A was set up to pre-trigger at -10%. Figure 6 shows how the emitter voltage builds after turn-on. The variation in the duty cycle of each pulse was investigated using the 5180A's dual trace display mode (Figure 7). The pulses displayed were taken from two different sections within a single captured data block. The first pulse had a width of 1.44  $\mu\text{sec}$ . Another pulse, occurring 750  $\mu\text{sec}$  later, had a width of 2.1  $\mu\text{sec}$ . The width under full load can get as wide as 10.8  $\mu\text{sec}$ . Post-trigger delaying and dual display operations allow simultaneously analyzing any two pulses in the train. Another 5180A feature, toggle time base, allows the user to specify two timebase rates and divide memory between them. For example, the user could sample at maximum speed on the first pulse (first time base rate), then sample very slow for a determined period (second time base rate), then return to the fast rate to catch a later pulse. Sample rate and time segmentation may be adjusted to capture any two pulses. An example application for toggle timebase mode is given in the section on turn-off transients.

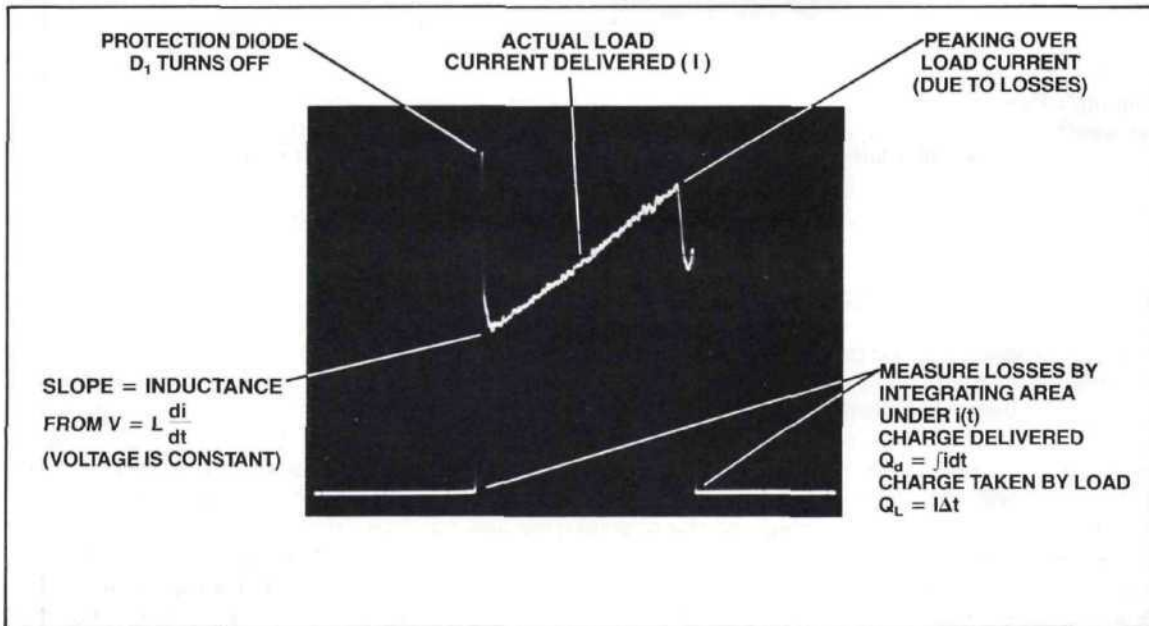

Figure 5. Expanded emitter current pulse.

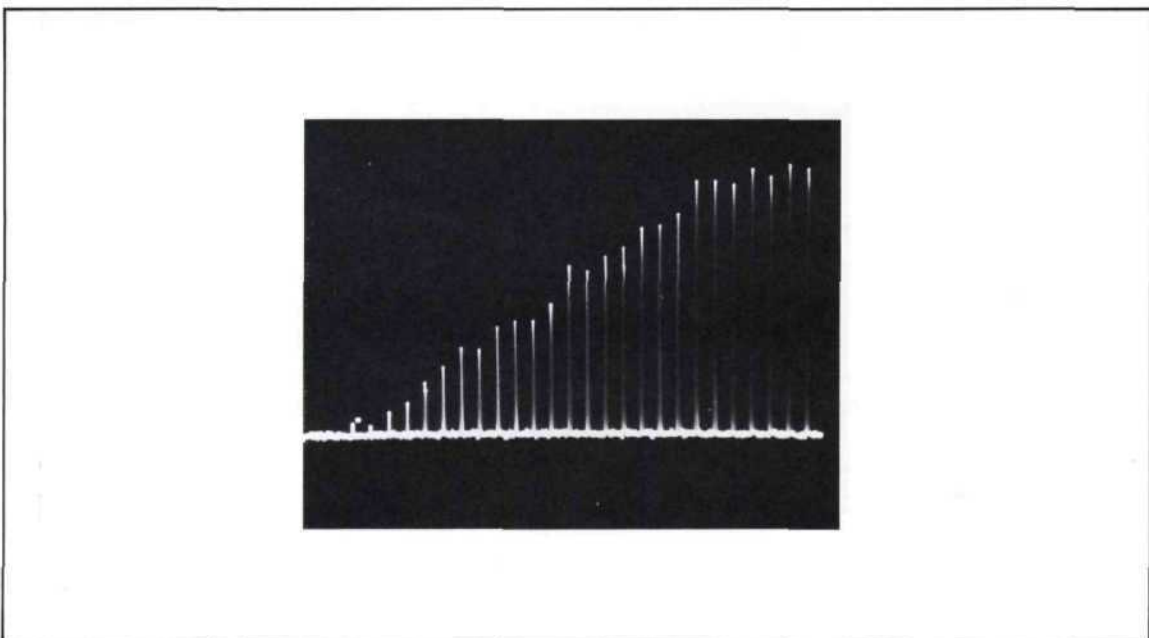
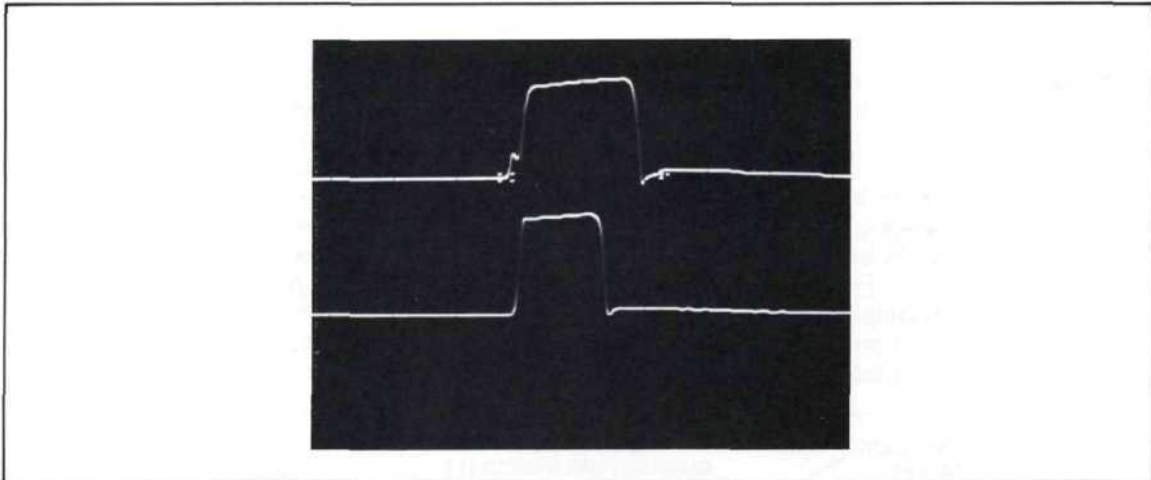

Figure 6. Emitter voltage at turn-on (-10% pre-trigger). Amplitudes controlled by the slow start circuitry.

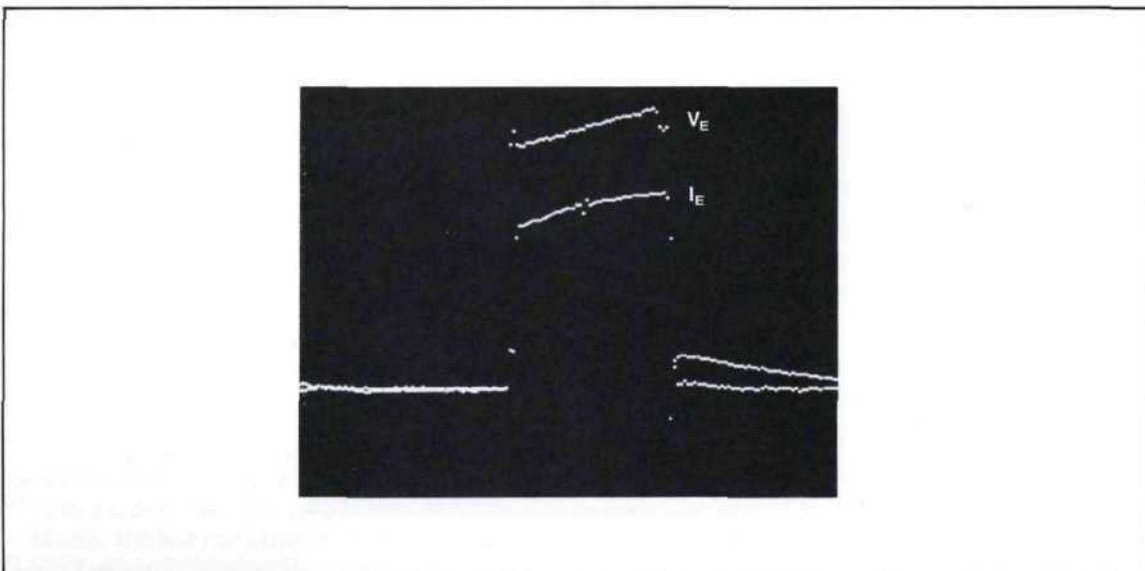

**Figure 7.** Pulse width comparison using dual trace. The bottom waveform is the first pulse in the train (emitter voltage pulse width at turn-on = 1.44  $\mu$ sec). The top trace shows another emitter voltage pulse, occurring 750  $\mu$ sec after turn-on. The latter pulse has a width of 2.1  $\mu$ sec. Cursors were used to measure both waveforms.

## Transistor Power Measurements

Power delivered by the pass transistor is one of the more important design parameters in the switching regulator circuit. The 5180A may be used along with a desktop computer to capture emitter voltage and current and then compute instantaneous power by multiplication of the two. Figure 8 is a dot mode display of an emitter voltage and current pulse. The two data records were transferred to a 9825 Desktop Computer for multiplication. Then the result was written to the 5180A's high speed memory for display. The result is shown in Figure 9 (line mode). The peak power delivered by the transistor is over 200 watts.

Significant temperature reduction may be realized if the switching transistor is brought out of saturation quickly (at the end of the pulse). The emitter voltage leads current and should be brought down before the emitter current reaches its peak. Figure 10 is an HP-GL plot of the current and voltage pulses. The annotations normally produced with an HP-GL plot have been deleted. Notice the alignment of emitter current and voltage. The power reduction is noted by reviewing Figure 9. The cause of the down-turn in peak power (Figure 9) is caused by the early drop in emitter voltage in Figure 10. This down-turn can save up to 50% in heat rise over ambient depending on pulse widths and magnitudes involved.



**Figure 8.** Emitter voltage and current waveforms (dot mode):

Top trace:  $V_E$   
Bottom trace:  $I_E$

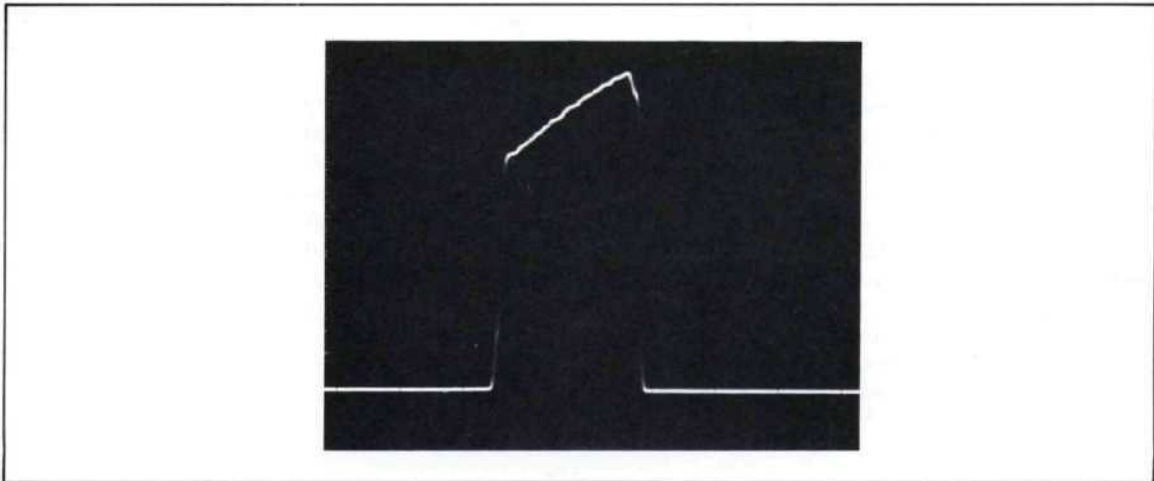

Figure 9. Instantaneous power, determined by multiplying  $V_E$  and  $I_E$  shown in Figure 8. The result was written to the 5180A and is displayed here.

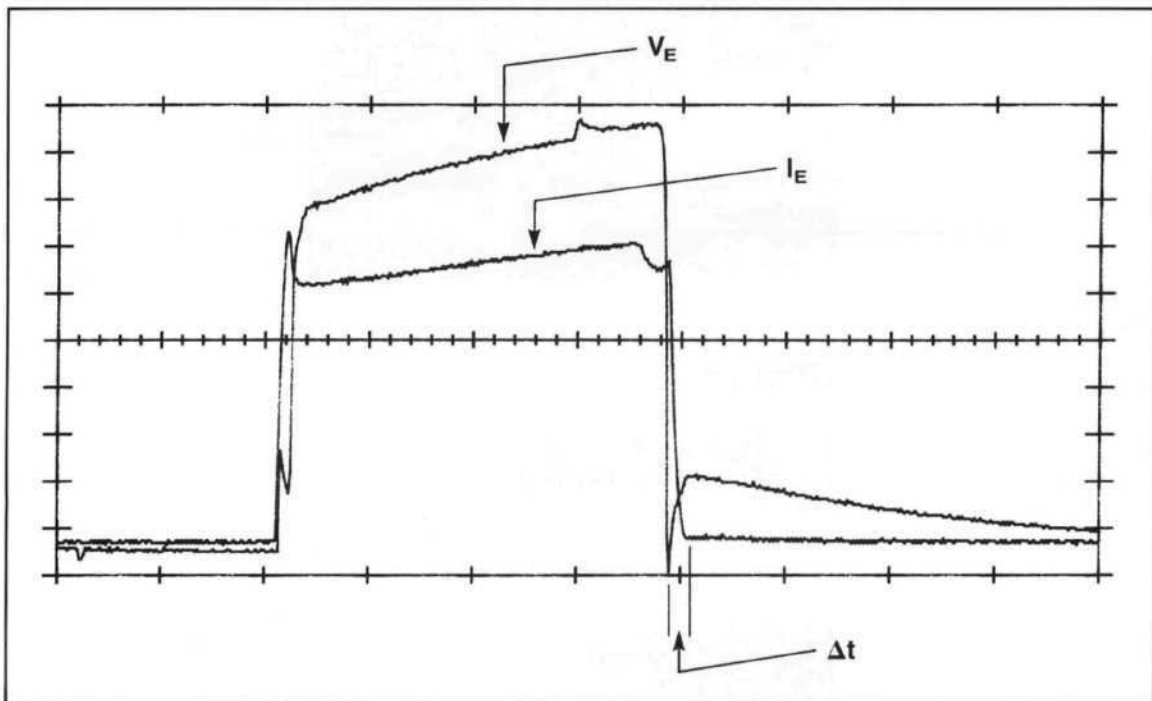

Figure 10. HP-GL plot (annotations deleted) of  $I_E$  and  $V_E$  pulses. The voltage lead time is indicated.

### Output Turn-Off Tests

Turn-off transients are somewhat difficult to capture using traditional scope techniques. Effectiveness depends on the turn-off time constant, a function which in turn depends on filter capacitors and bleeder resistance. The unloaded turn-off test, having time constants that may reach several seconds, is nearly impossible to perform with a standard scope. Even with a storage scope, the effectiveness isn't ideal. Pre-trigger top line information can't be shown so fall times can't be measured. The data, not in digital form, can't be processed automatically. A waveform recorder's pre-trigger and digital output capabilities offer measurable advantages in capturing turn-off events.

Fall times, loaded and unloaded, were compared using the 5180A. Figure 11 shows turn-off results for the unloaded (top trace) and the loaded (lower trace) tests. Trigger setup was position -10%, level 4.60V, negative slope, and is indicated by the intensified dots. Sample rate was 500  $\mu$ sec per point. The unloaded fall time was 1.8 sec (100% to 0). Both waveforms were sampled at the same rate to show the relative difference in fall times.

The loaded turn-off was further investigated using a unique timebase mode. In transient recording, it's often advantageous to change sample rates during the measurement. The turn-off transient requires fast sampling during the transition, especially if waveform analysis is to be performed. Slower sampling may be used to conserve memory on top and base lines, where data is only needed for reference. The 5180A's dual timebase was programmed in a toggle mode where the sample rate changed to a faster rate during transition (5  $\mu$ secs per sample). Sample rate for the top and baseline was 500  $\mu$ sec per sample. The width of the fast sample window was chosen to be 10.3 msec using the trigger position control. The resulting loaded fall time was 46.2 msec, compared to 1.8 sec for unloaded. The results are shown in Figure 12. The multi-sloped nature of the transition was due to regulator cutoff and protective circuitry (cutoff hold-up circuitry) that prevents ground undershoot.

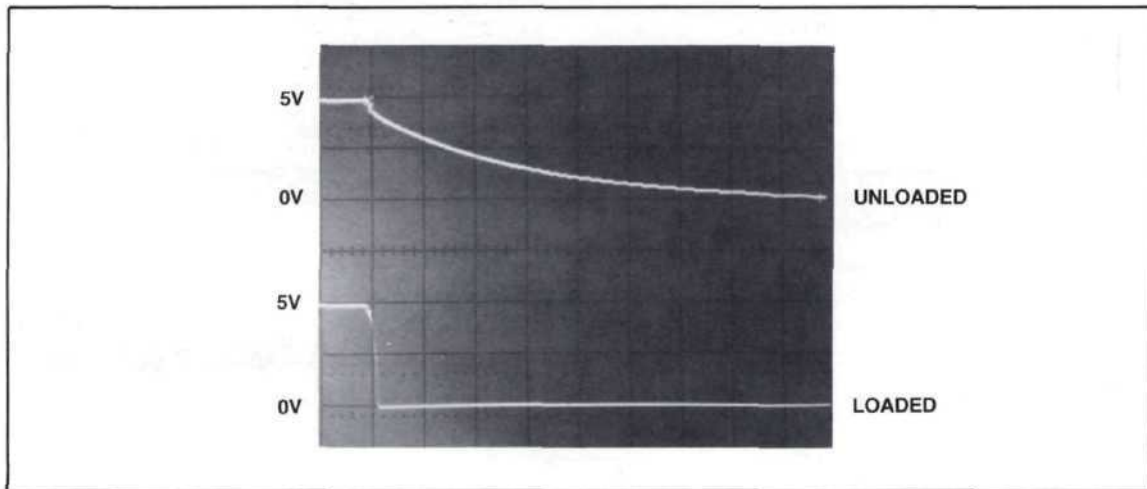

**Figure 11.** Dual trace comparison of unloaded (top trace) and loaded (bottom trace) turn-off. Cursors show 1.8 sec fall time for the unloaded test.

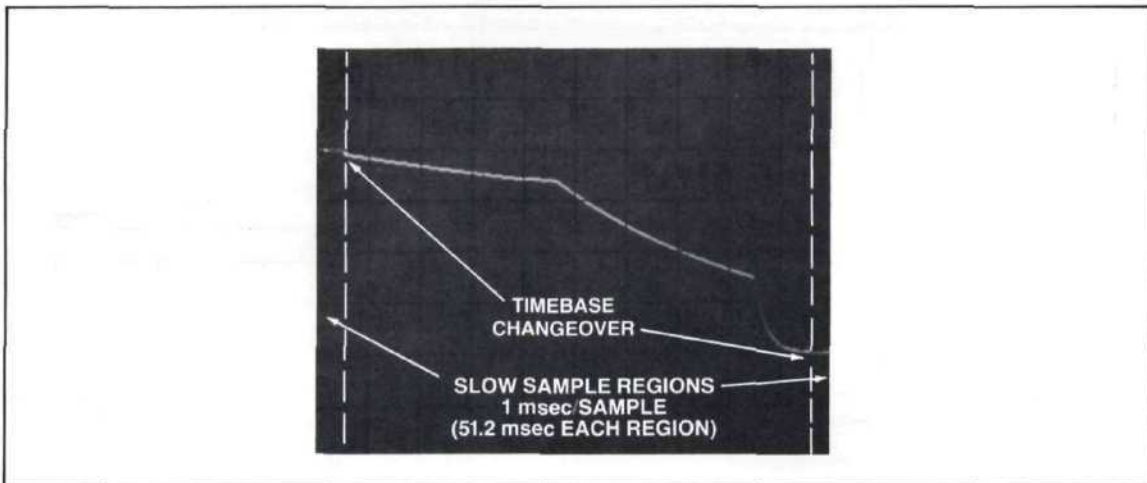

**Figure 12.** Toggle timebase samples fast on transition, slow on top and base lines. Fall time for loaded turn-off was 46.2 msec. Record length was 1024 points with 5% top and base lines. 90% of record length covered the fast sample period.

### Load Effect Transient Recovery (Step Load Test)

Perhaps the most difficult power supply transient test is step load recovery — the response to a step load change at the output. How fast does the power supply return to regulated output conditions after the step load has been applied? Does an over-voltage or over-current protection circuit accidentally trigger? Is there overshoot or oscillation? A waveform recorder offers the easiest way to find the answers.

Load effective transient recovery time for a constant voltage supply is generally defined as:

*The time required for the output voltage to recover to a specified voltage after a step load change of  $\Delta I$  amps is forced at the output.*

A typical waveshape is given in Figure 13. The unloading test requires changing the load current from 20% to 100% of rated maximum. Similarly, unloading requires a 100% to 20% load change. For both, power supply vernier current limit controls are set to maximum.

The 5180A was used with an active load circuit to perform loading and unloading recovery tests. A typical dynamic load circuit is presented in Appendix A. A constant voltage switching supply, exhibiting a noisy output, was tested. Figures 14a and 14b show the AC-coupled loading and unloading transients, respectively. A 4096 point record length was chosen. Sample rate was 500 nsec per point, giving a measurement time of 2.048 msec. In the loading test, a 2A to 10A current step caused an initial voltage drop of 460mV with a recovery time of 1.27 msec.

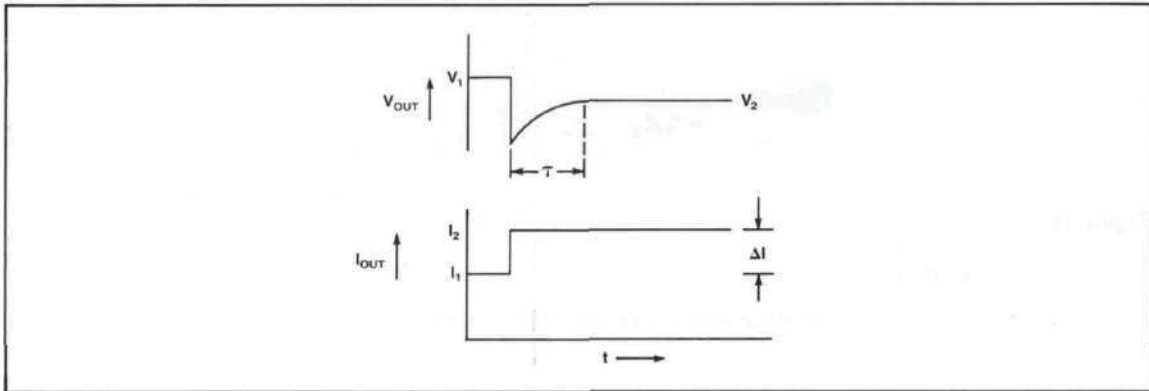

**Figure 13.** Step Load Recovery Test (Loading).  $I_1$  to  $I_2$  ( $\Delta I$ ) step current imposes  $V_1$  to  $V_2$  voltage changes.  $V_2$  usually will be slightly less than  $V_1$  and is specified. Step Load Recovery Time is  $T$ .

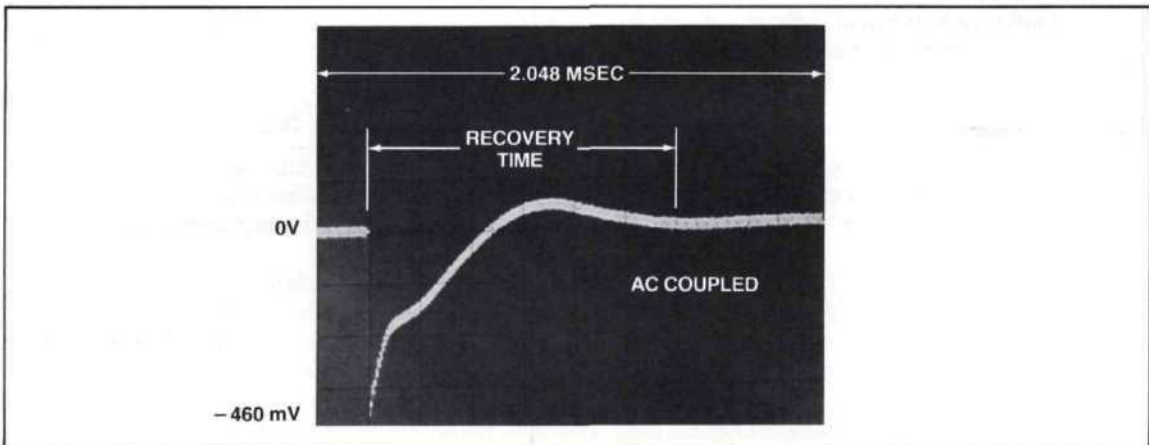

**Figure 14a.** Loading recovery test results for a 2A to 10A current step (AC coupled). Recovery time was 1.27 msec.

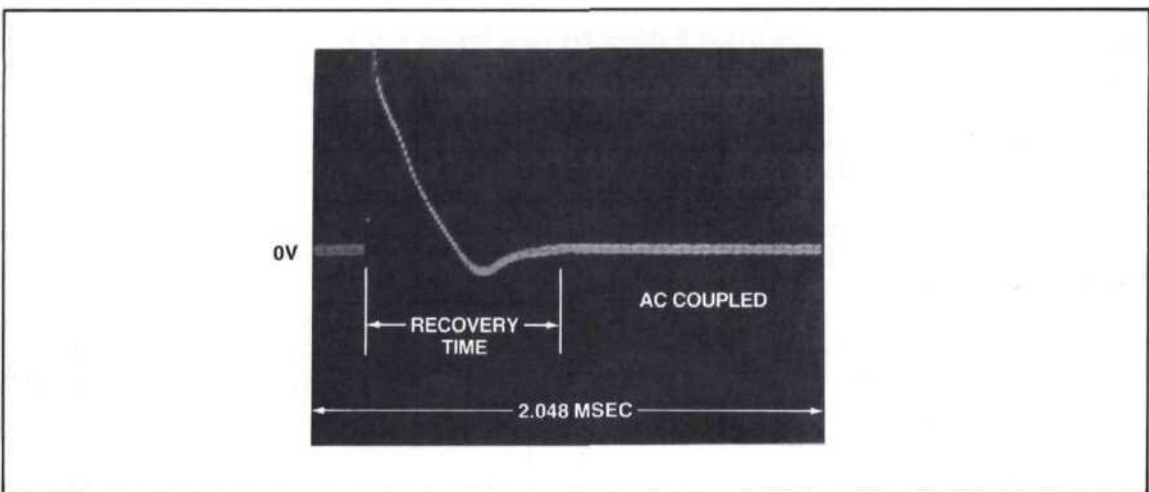

**Figure 14b.** Unloading recovery test (AC coupled), 10A to 2A current step resulted in a 819  $\mu$ sec recovery time.

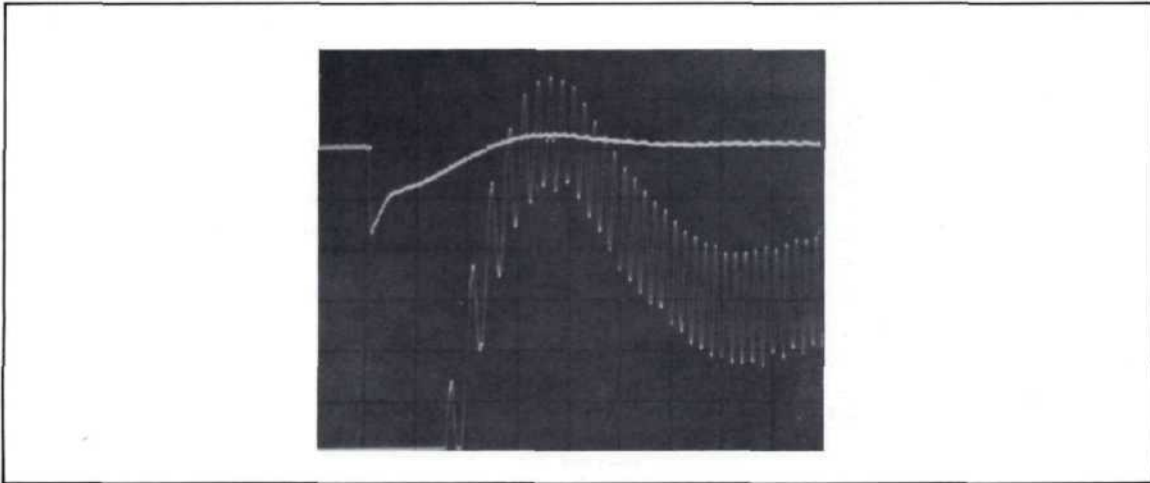

**Figure 14c.** Loading transient expanded for observation. Original transient expanded and shown with  $\pm 0.64V$  display range. The horizontal of the expanded waveform is centered in the vicinity of the overshoot and covers  $512 \mu\text{sec}$ . The original waveform covers  $2.048 \text{ msec}$ . The oscillation is  $400 \text{ KHz}$ .

Power supply noise was investigated in Figure 14c. The top trace is the loading transient, reduced and offset for viewing convenience. The second trace displays the same data, expanded for inspection. The expanded waveform covers 1024 consecutive points in the time vicinity of the overshoot (locate the cursor). The vertical expansion covered  $\pm 0.64$  volts. The oscillation, caused by a faulty filtering circuit in the switcher circuitry, had a measured frequency of  $400 \text{ KHz}$ . Often, impedance characteristics of the load circuit and the power supply output can induce stable oscillations. The presence of this noise makes the recovery time measurement difficult – it isn't easy to tell where the output voltage has recovered to the nominal level. In many rise and fall time measurements, accuracy may be enhanced if noise components are removed from the data.

### Post-Processing Technique for Reducing Step Load Noise

A waveform recorder's digital output makes processing measurement results convenient. In the step load example, a digital lowpass filter could be applied so that the  $400 \text{ KHz}$  noise component is removed. The desired characteristics of the filtering technique would also include preserving the transient waveshape.

Intuitively, the best way to remove noise is to average data. Several complete records of the transient could be captured, then averaged, point by point. With a single data record, however, an average must be applied to sequential data points so that the undesirable signal characteristics are removed. A last-N moving average filter was developed and applied to the captured data. "Last-N" means that a selected number of sequential data points are averaged to produce a single corrected data point. Analysis shows that an N-point average is actually a lowpass filter. The basic parameters of the filter include N, the number of points averaged, and T, the sample rate applied in the measurement. The parameter T must have units of time/point. A more detailed analysis of the last-N technique is presented in Appendix B.

### Application of an Averaging Filter to the Step Load Signal

The step load signal is repeated in Figure 15 (HP-GL plot of Figure 14a). The digital signal is to be filtered using an  $N = 5$  averaging technique (the  $400 \text{ KHz}$  noise component is to be removed). The sample rate applied in digitizing the data was  $500 \text{ nsec/point}$ .

*The  $400 \text{ KHz}$  component falls at the first minimum of the filter's gain function and will be reduced by up to  $30\text{dB}$ .*

An averaging program was implemented with the 9825 Desktop computer. A program listing and description is presented later. The routine given allows using the 5180A cursors to bracket a portion of the captured record for correction. Figure 16 is a 5180A plot of the smoothed waveform. The noise component has been significantly reduced while the rise time characteristics have been preserved. The recovery time obtained from the converted waveform was  $1.184 \text{ msec}$ . The recovery time estimated from the original data was  $1.27 \text{ msec}$ . Figure 17 shows display expansions of the original and filtered waveforms in the vicinity of the overshoot. Dot and line mode photos are given (Figures 17a and 17b). The noise was reduced by  $19.8 \text{ dB}$ .

The program allows a second pass through the digital filter. The result of second pass filtering is shown in Figure 17c (again, the original and filtered data are expanded and displayed simultaneously). The second pass resulted in further reduction of the noise component ( $-25.2 \text{ dB}$ ).

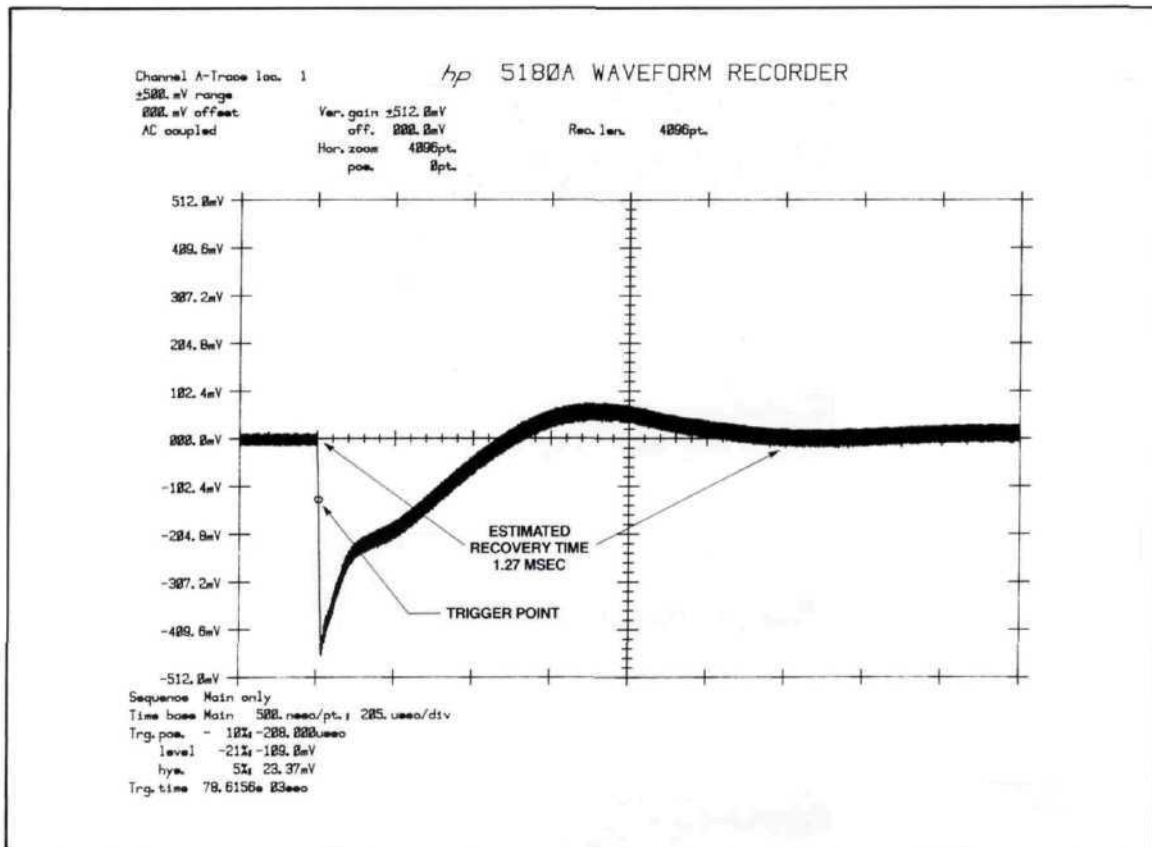

Figure 15. HP-GL plot of step load recovery transient. The noise signal is 400 KHz.

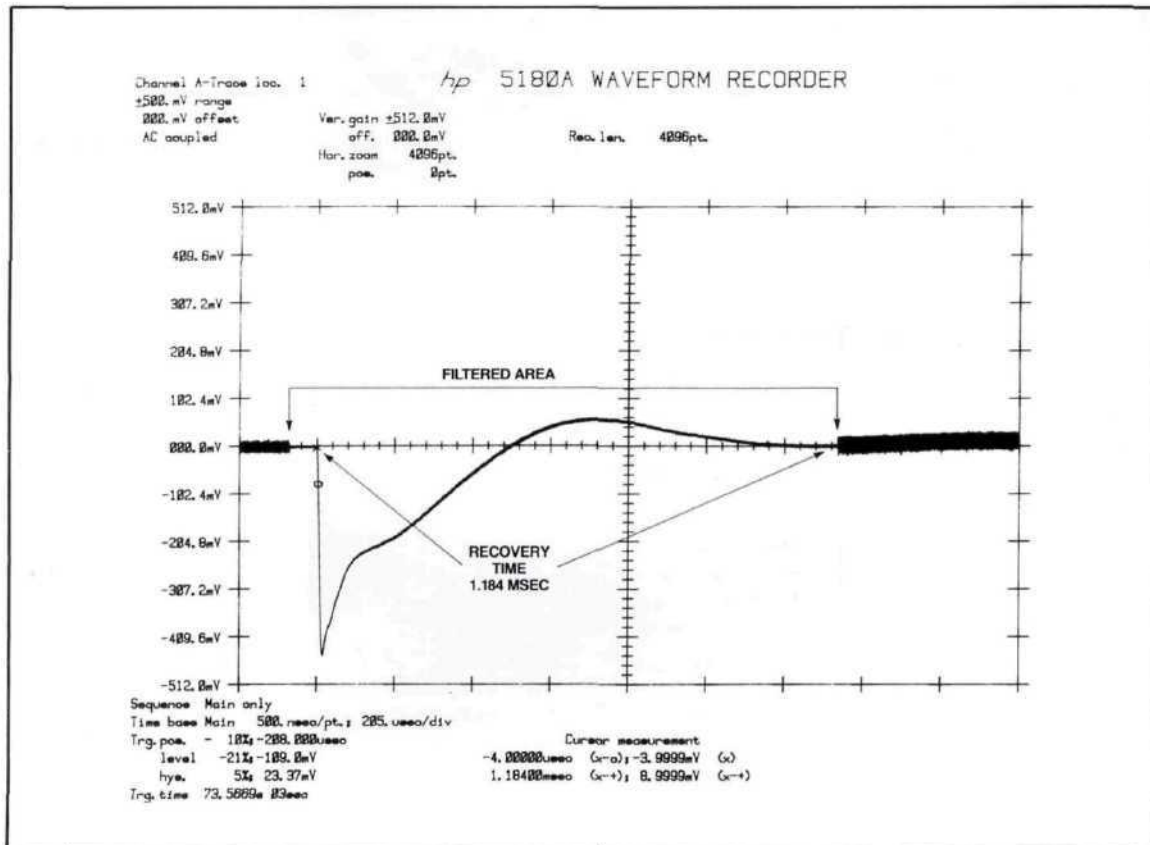
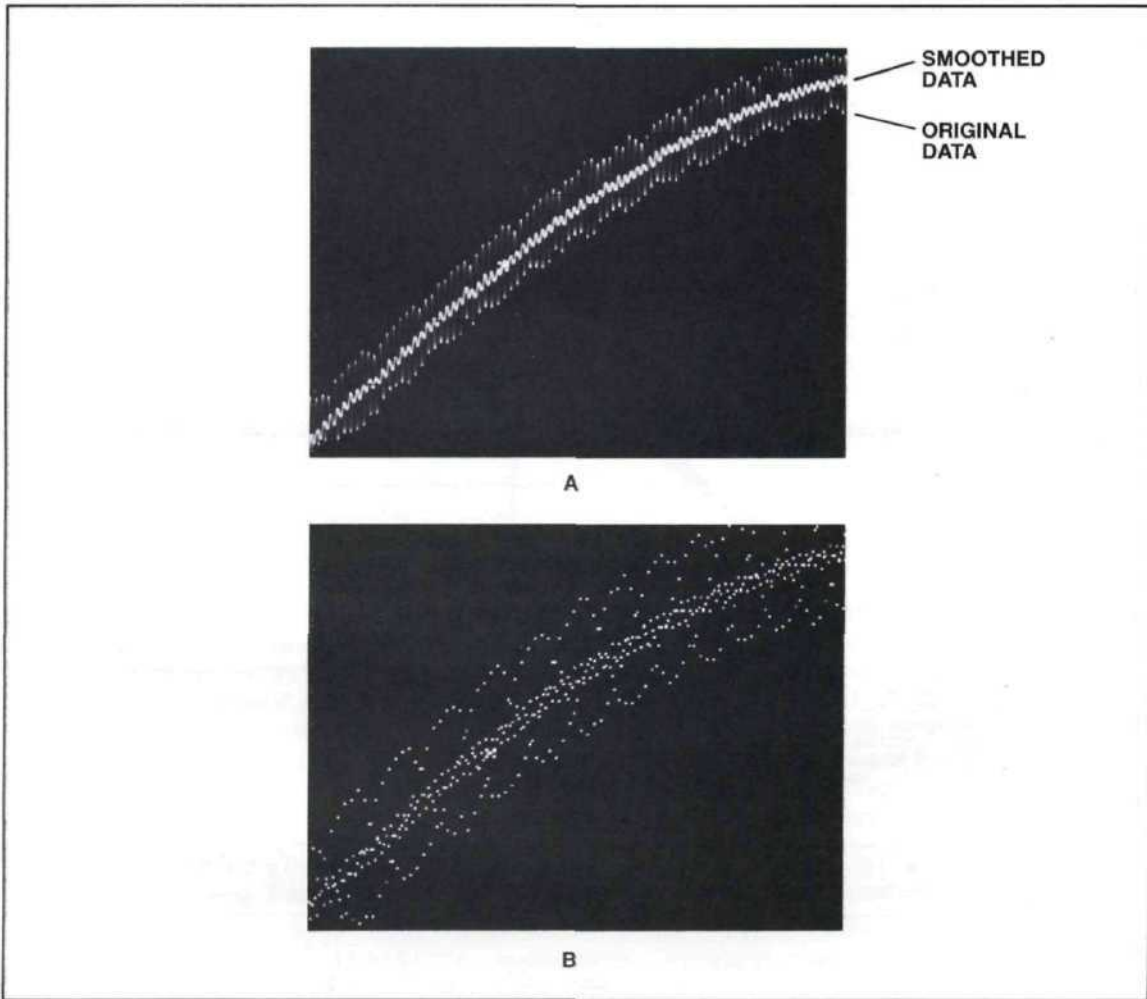

Figure 16. HP-GL plot of filtered step load recovery. Correction applied was a N = 5 average filter (single pass).



**Figure 17.** Data correction results

a,b Dot and line mode photos of the corrected waveform and the original in the vicinity of the overshoot (expanded using gain and zoom).

Original noise:	39 mV p-p	-19.8 dB
1st pass correction:	4 mV p-p	

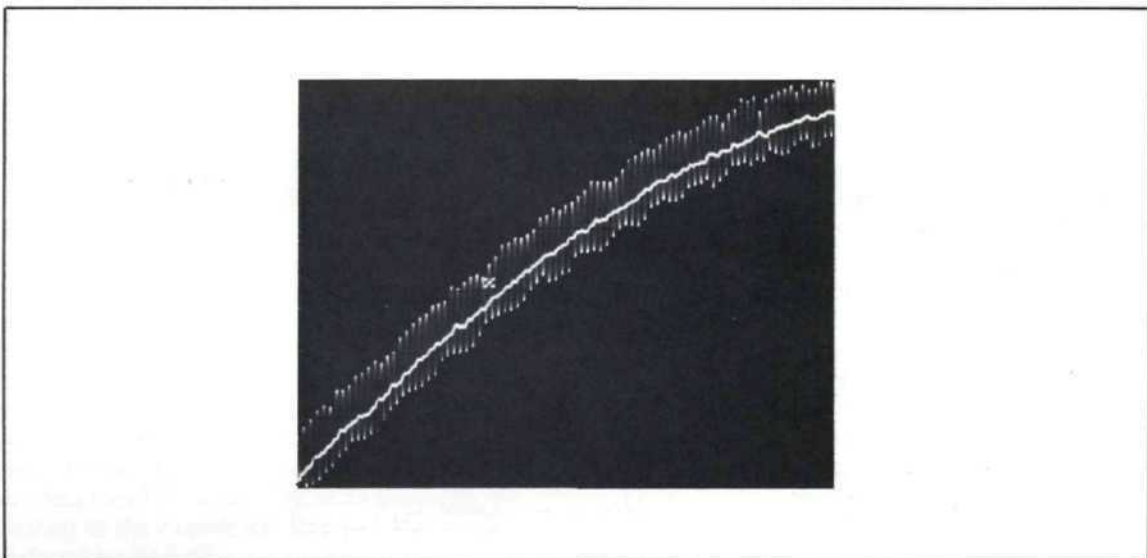

<b>Figure 17. c</b>	Result after 2nd pass correction:		
	Original noise:	39 mV p-p	-25.2 dB
	2nd pass correction:	2.15 mV p-p	

### Example Program: Last-N Average

The program listed allows the user to bracket a specific portion of a 4096 point record for correction. The data to be corrected may come from stored tape data or from a measurement. In either case the 5180A record length must be 4096 points. Record location 1 is used.

The  $N=5$  averaging filter is implemented in the "average" subroutine. Any suitable filtering, smoothing, or averaging algorithm may be used in place of "average".

After the data is smoothed, a second pass average may be applied. The "again" subroutine provides this capability. When all smoothing routines are complete, the original waveform is recalled from tape and is displayed. A Trace 1 – Trace 2 comparison may be executed. The difference waveform should be relatively flat throughout the smoothed area (if the filter is for the purpose of removing the 400 KHz component, then the difference signal should be the 400 KHz component). Deviations from a flat pattern indicate places where the constructed waveform failed to pass through the center points of the original data. Figure 18 is a Trace 1 – Trace 2 display after a single pass average was applied to the original data (the corrected data was shown in Figure 16). The initial deviation from the flat noise pattern expected indicates that the  $N=5$  filter made some small errors in that area. The peak voltage error between the original data points and the smoothed data points was measured to be 50mV.

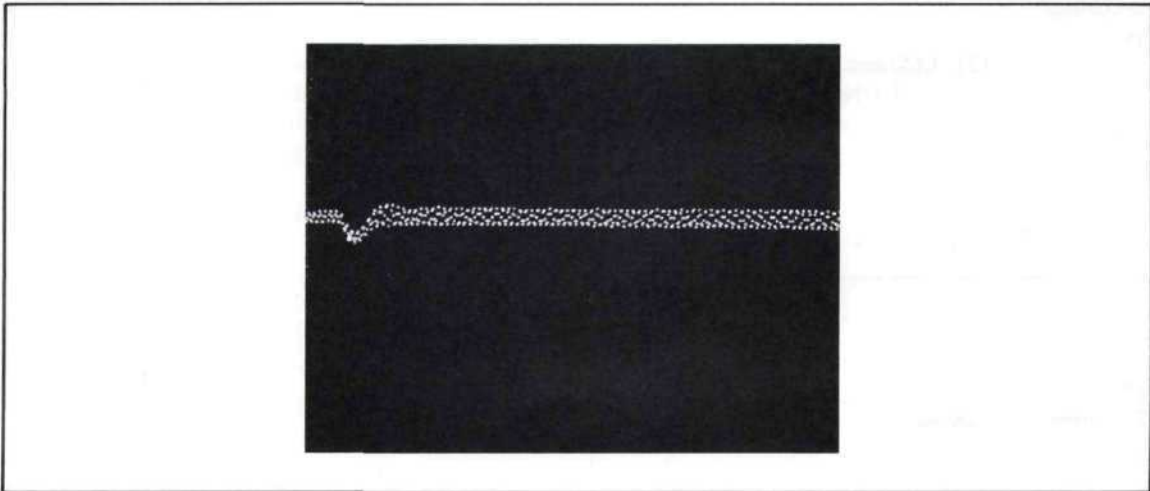

**Figure 18.** Trace 1-Trace 2 display of original data minus corrected data. Flatness over the corrected region shows good center line fit to the original data (the difference waveform is the noise component that was removed).

# APPENDIX A

## Power Supply Loading

In general, resistance and wattage of the test load should allow operating the power supply at maximum voltage and current. Transient measurements require using non-inductive loads so that recovery times are not affected. The load recovery test is carried out by causing a resistance or current step change at the power supply output. Manually switching the load can be inadequate because a finite resistance must be maintained during the transition. Switch bounce noise can make transient analysis difficult. The recovery test has been historically performed using a relay-switched repetitive load change which was synchronized to oscilloscope sweep. Mercury wetted relays may be used for small load currents but, when rated for larger loads, become too heavy for fast switching.

Active transistor load circuits are a simple solution to the loading problem. A typical circuit implementation is shown in Figure A1. The heart of the load circuit is the active transistor array. A sufficient number of transistors are paralleled to meet the load requirements. The load current is programmed by supplying a program voltage to the input of error amp U1. Rapid load changes, such as those required for the step load recovery test, are achieved by applying a step voltage to U1. The slew rate of the current step output is controlled by the input resistors R1, R2 and the capacitor C1. R1 and R2 also provide attenuation to the program voltage applied.

Transistors Q1, Q2, and Q3 are emitter followers that supply base current to the load array. Fewer followers may be used if the operational amplifier has sufficient drive capability. Resistors R3, R4, . . . for each array load transistor act as a summing network to provide feedback to the error amplifier. The summing resistors are typically about 10 ohms. The emitter resistors for each array load transistor R are much smaller (0.05 ohms).

Over-current protection may be added as shown. The sense circuit may be a simple voltage comparator that compares a reference to the SENSE feedback line.

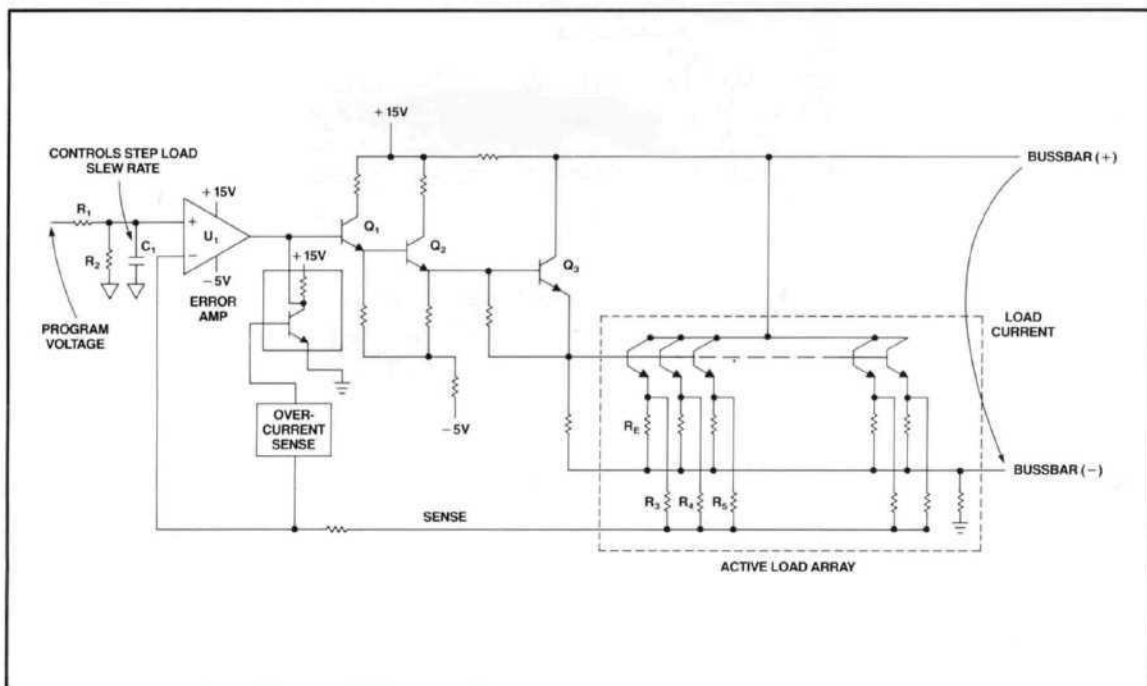

Figure A1. Active load circuit

- Program Voltage may be constant or stepped for static or dynamic loading
- Current may be determined by capturing sense line waveform

## APPENDIX B

### Extracting Signal Characteristics through Digital Post-Processing

A method for removing the unwanted noise component from the step load recovery signal has been presented. The "last-N" lowpass filter illustrates the power of post-capture processing in extracting hidden information from a set of data points.

The characteristics of the step load signal are determined by applying appropriate signal transformations; in this case, averaging.

The "last-N" moving average produces a value  $y(n)$  at each sample point by averaging the last  $N$  captured data points. If  $x(n)$  represents the sequence of captured data, then the "last-N" value  $y(n)$  is given by

$$y(n) = \frac{1}{N} [x(n) + x(n-1) + \dots + x(n-(N-1))] \quad \text{EQ. 1}$$

This can be written as a convolution sum by noting that the filter weighing, or impulse response, is equal to  $1/N$  for  $n = 0, 1, \dots, N-1$  and zero otherwise. Thus, if  $h(n)$  is the impulse response:

$$y(n) = \sum_{K=0}^{N-1} h(n)x(n-K) = \frac{1}{N} \sum_{K=0}^{N-1} x(n-K) \quad (\text{convolution sum}) \quad \text{EQ. 2}$$

Figure B1 shows an implementation of the moving average  $N = 5$ , near the point  $n = 15$ .

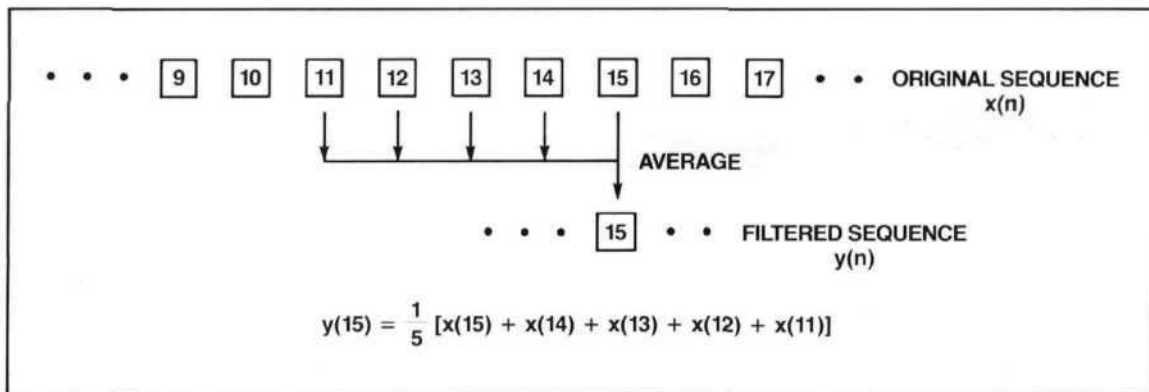

Figure B1.  $N = 5$  average near  $n = 15$

The frequency response of this simple lowpass filter is the Discrete Fourier Transform of its impulse response and is denoted by  $H(j\omega)$ .

$$H(j\omega) = \frac{1}{T} \sum_{n=0}^{N-1} h(n)e^{-j\omega n} = \frac{1}{NT} \sum_{n=0}^{N-1} e^{-j\omega n} \quad \text{EQ. 3}$$

where  $T =$  sample period applied. In the example,  $T = 500\text{nsec/point}$

$\omega =$  Discrete Fourier frequency variable

The relationship between  $\omega$  and input frequencies  $F_a$  is given by

$$\omega = (2\pi F_a)T$$

In the step load example, the 400 KHz component is located at  $\omega = 0.4\pi$  ( $T = 500\text{ nsec}$ ,  $F_a = 400\text{ KHz}$ ).

Since the sample rate applied must be at least twice the highest frequency component found in the sampled waveform, the maximum value of  $\omega$  is equal to  $\pi$ .

A more useful form for EQ. 3 is found by expanding the summation.

$$|H(j\omega)| = \underbrace{\frac{1}{NT} \frac{\sin(N \frac{\omega}{2})}{\sin(\frac{\omega}{2})}}_{\text{magnitude}} e^{-j(N-1) \frac{\omega}{2}} \quad \text{EQ. 4}$$

delay

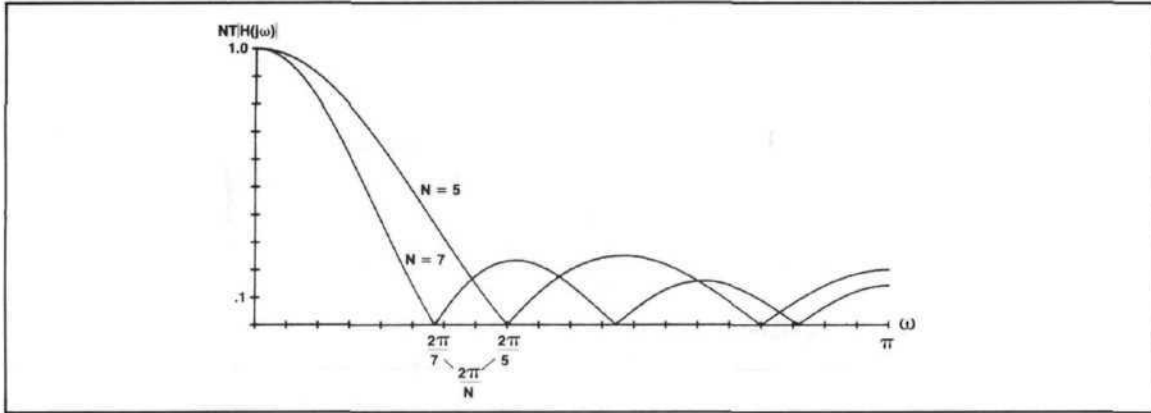

Figure B2. Magnitude responses for  $|H(j\omega)|$  from  $\omega = 0$  to  $\omega = \pi$ . First minimum is always  $2\pi/N$ . The function is given by:

$$|H(j\omega)| = \frac{1}{NT} \frac{\sin(N \frac{\omega}{2})}{\sin(\frac{\omega}{2})}$$

The magnitude and group delay elements of  $H(j\omega)$  are indicated. The magnitude of  $H(j\omega)$  can be written as  $|H(j\omega)|$  and is plotted in Figure B2. Responses for  $N = 5$  and  $N = 7$  are given. The first response minimum for any  $N$  occurs at  $2\pi/N$ . Increasing  $N$  increases the number of lobes to the right of  $2\pi/N$  and narrows the width of the main lobe. Values of  $N$  between 3 and 7 produce convenient "last- $N$ " filters because the moving average is easily implemented.

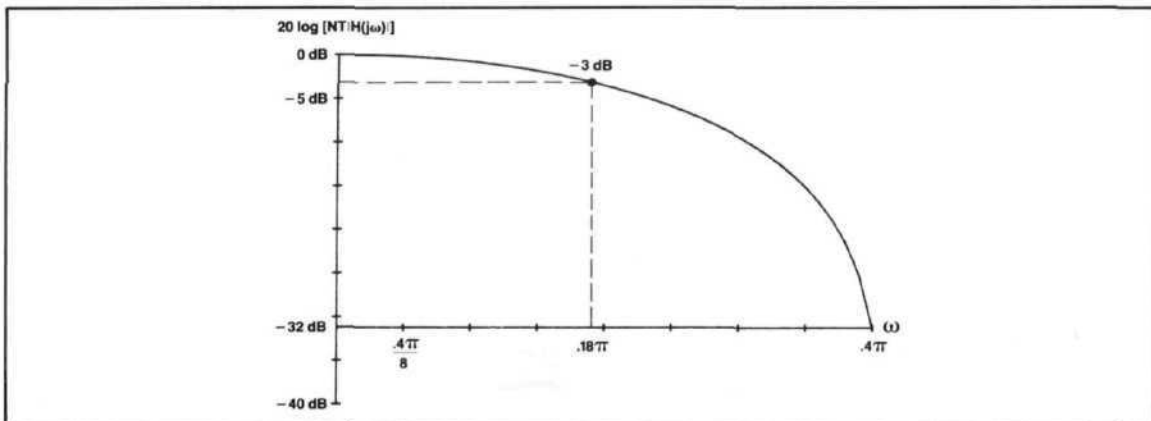

Figure B3. Log amplitude plot of  $|H(j\omega)|$  when  $N = 5$ .

Maximum cutoff rejection is realized by utilizing only the main lobe of the filter. In other words, if the highest frequency present ( $F_c$ ) is less than  $1/NT$ , no frequencies will be present in the bands greater than  $2\pi/N$ . In the step load example, the 400 KHz component falls at the first minimum of the response function.

Ideally, the first minimum is 30 dB below the pass band. A normalized log plot of  $|H(j\omega)|$  from  $\omega = 0$  to  $0.4\pi$  is given in Figure B3.

The effective cutoff frequency for the filter is 400 KHz and is found by:

$$F_c = \frac{\omega_c}{2\pi T} = \frac{0.4\pi}{2\pi (500 \text{ nsec})} = 400 \text{ KHz}$$

## Phase Delay

All filters, either analog or digital, exhibit a phase characteristic. The phase response of the "last-N" filter is given by:

$$\theta = -\frac{N}{2} \left(1 - \frac{1}{N}\right) \omega$$

and is linear. In relation to the original sample sequence  $x(n)$ , the smoothed sequence  $y(n)$  will be delayed by a few samples. Since the shift is linear, group delay is constant and phase distortion is prevented.

The 400 KHz component is delayed by only 1.6 samples (800  $\mu$ sec). Figure B4 shows the effect of sample shift at the 3 dB frequency ( $0.18\pi$  or 180 KHz). A 180 KHz sine wave was digitized with a sample period of  $T = 500$  nsec/point (top trace). The data was post-processed using the  $N = 5$  lowpass filter. The resulting waveform (bottom trace) is 3 dB down and has a phase delay of 0.72 samples (360 nsec).

The combination of 5180A Waveform Recorder and a compatible HP-IB computer allows powerful signal processing functions to be implemented. A very simple example showing the advantages of post-capture processing has been described. Highly sophisticated filtering operations may be readily implemented, enabling easy solutions to traditionally difficult measurement problems.

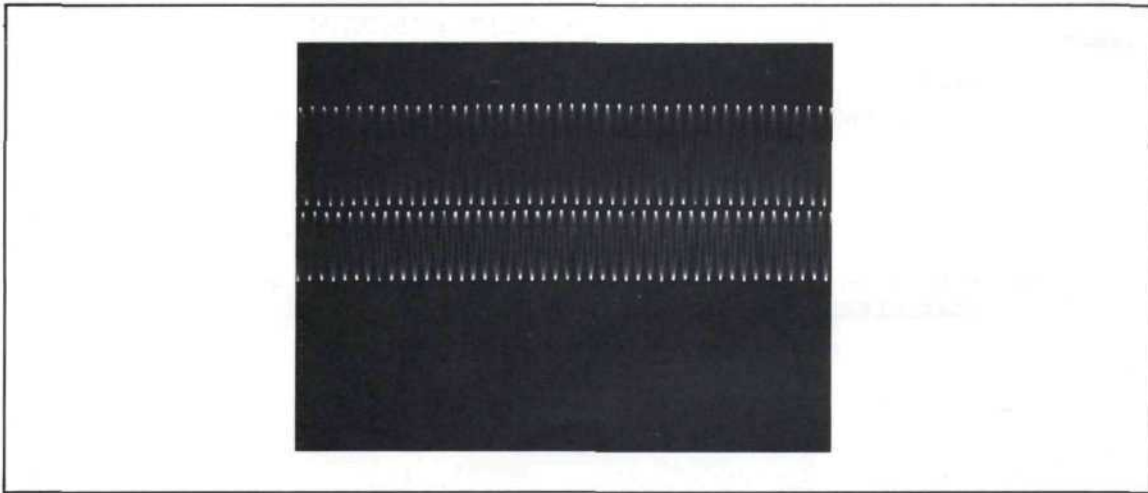

**Figure B4.** Sample shift at 3 dB frequency (180 KHz). Upper trace is the input sinewave. Lower trace is the filtered result (3 dB down, shifted 0.72 samples or 360 nsec).

```

0: "start":
1: dev "80",704;wrt "80","c11,mc0,dc0";lcl "80"
2: dsp "5180A Data Correction Pgm";wait 1000
3: dim C$(200),D$(8192+16),F$(32),S$(512);conv 39,101
4: buf "data",D$,3
5:
6: "select":
7: ent "tape or measure? t or m (CONT)",F$
8: if F$="t" or F$="T";gto "tape"
9: if F$="m" or F$="M";gto "measure"
10: beep;ent "illegal - t or m (CONT)",F$;jmc -2
11:
12: "tape":
13: dsp "get data from tape"
14: fdf 0;ldf 0,S$
15: dsp "5180A setup in progress"
16: wrt "80",S$
17: if bit("lxxx",rds("80"));gto +0
18: fdf 1;ldf 1,D$
19: wtb 704,"ibl,"
20: tfr "data",704,8192
21: if rds("data")=-1;dsp "inputting data";gto +0
22: dsp "transfer finished (CONT)"
23: beep;lcl "80";stp
24: gto "curs window"
25:
26: "measure":
27: beep;dsp "set up 5180A manually (CONT)"
28: lcl "80";stp
29: wrt 704,"sal,sa4"
30: if bit("l0xxx",rds("80"));gto +0
31: if bit("0xx",rds("80"));dsp "waiting for trig";gto +0
32: beep;dsp "measurement complete (CONT)"
33: lcl "80";stp
34: wrt "80","oal";red "80",S$
35: if bit("lxxx",rds(704));gto +0
36: wrt "80","bbl"
37: tfr "80","data",8192
38: if rds("data")=-1;dsp "reading 5180A data";gto +0
39: beep;dsp "insert data tape (CONT)";sto
40: dsp "recording data"
41: fdf 0;rcf 0,S$
42: fdf 1;rcf 1,D$
43: dsp "4096 points saved(CONT)"
44: lcl "80";stp

```

Initialize variables and "data" buffer.  
Display calibration signal on CRT.

Select "Tape" or "Measurement" program.

"Tape"  
Get data and setup conditions from  
tape. Write information to 5180A.

"Measure"  
Setup 5180A to make a measurement.  
When measurement is complete,  
transfer data and setup conditions  
to 9825 and save on tape.

```

45:
46: "curs window":
47: dsp "curs window";wait 1000
48: wrt "80","cu0,cv1"
49: lcl "80"
50: beep
51: dsp "put cursor at start (CONT)";stp
52: wrt "80","oc";red "80",C$
53: pos(C$,"cu")+2+C;val(C$[C]) +C
54: val(C$[pos(C$[pos(C$,"trl")+P],"po")+P+2]) +P
55: val(C$[pos(C$[pos(C$,"trl")+Z],"zo")+Z+2]) +Z
56: P+int((Z/1024)C)+L
57: wrt "80","cu",1023
58: beep
59: dsp "put cursor at stop (CONT)"
60: wrt "80","cv1"
61: lcl "80";stp
62: wrt "80","oc";red "80",C$
63: pos(C$,"cu")+2+D;val(C$[D]) +D
64: val(C$[pos(C$[pos(C$,"trl")+P],"po")+P+2]) +P
65: val(C$[pos(C$[pos(C$,"trl")+Z],"zo")+Z+2]) +Z
66: P+int((Z/1024)D)+U
67: if L>0;beep;dsp "ERROR- stop must be right";wait 3000;gto 57
68: U-L+1+N
69: pos(S$,"mm")+2+T;val(S$[T]) +T
70: fxd 0;prt "# points:";prt N;spc 1
71: flt 3;prt "time";prt "window:";T(N-1);spc 2
72:
73: "fix disp":
74: wrt "80","mc0,dc0"
75: wrt "80","hfvfct1"
76: int(L/4) +A;int(J/4) +B
77: wrt "80","cu",A;wrt "80","cd",E
78: dsp "display fixed (CONT)"
79: lcl "80";stp
80:
81: "read data window":
82: fmt 3,"bsl",",",",",i",",",i",",",z
83: buf "data"
84: wrt "80.3",L-3,N+3
85: tfr "80","data",2(N+3)
86: if rds("data")=-1;dsp "reading window";gto +0
87: dsp "window data transferred";stp
88:

```

Determine starting position for data correction. Memory sample location = L.

Determine stop position for data correction. Memory sample location = U.

Determine number of points in the window, N. Print time window information.

Remove horizontal and vertical expansion factors and place cursors at start/stop points.

Read in data between cursors. Must read 3 points before L. Last point read is location U.

```

89: "average":
90: fixd 0
91: fmt 4,"isl",",",",f",",",f",",",z
92: wrt "80.4",L+1,N-1
93: rdb("data")*32+rdb("data")/8+r20
94: rdb("data")*32+rdb("data")/8+r21
95: rdb("data")*32+rdb("data")/8+r22
96: rdb("data")*32+rdb("data")/8+r23
97: for I=L+1 to U
98: dsp "calculating",I-(L+1)
99: rdb("data")*32+rdb("data")/8+r24
100: frc(r 25) +r26
101: if r 26>.5 or r26=.5;int(r 25)+1+r25
102: if r 26<.5;int(r 25)+r25
103: (r 20+r21+r22+r23+r24)/5+r25
104: wtb "80",band(shf(r 25,5),255)
105: wtb "80",band(shf(r 25,-3),255)
106: r 21+r20;r 22+r21;r 23+r22;r 24+r23
107: next I
108: dsp "data corrected (CONT)";lcl "80";stp
109:

```

Average data and write results to 5180A. Implementation for N = 5.

Round each point written to nearest one-half code.

```

110: "again":
111: ent "re-average data? y or n (CONT)",F$
112: if F$="y" or F$="Y";gto "read data window"
113: if F$="n" or F$="N";gto "write original"
114: beep;ent "illegal - enter y or n (CONT)",F$;jmp -2
115:

```

Apply another connection to data?

```

116: "write original":
117: buf "data"
118: dsp "loading waveform from tape"
119: fdf 1;ldf 1,D$
120: dsp "inputting data to 5180A"
121: wtb "80","ib2,"
122: tfr "data","10",8192
123: if rds("data")=-1;dsp "inputting data to 5180A";gto +0
124: wrt "80","trl,hfvftr2,hfvf,trl"
125: wrt "80","trl,tl2,tr2,tll"
126: wrt "80","du"
127: dsp "data transferred - dual trace (CONT)"
128: lcl "80";stp
129:

```

Load original data from tape and write to 5180A. Display both the original and corrected waveforms.

```

130: "subtract":
131: dsp "waveform subtraction"
132: wrt "80","anl"
133: end

```

Instruct 5180A to execute Trace 1-Trace 2 for comparison of original and corrected waveforms.



For more information, call your local HP Sales Office or nearest Regional Office: **Eastern** (201) 265-5000; **Midwestern** (312) 255-9800; **Southern** (404) 955-1500; **Western** (213) 970-7500; **Canadian** (416) 678-9430. Ask the operator for instrument sales. Or write Hewlett-Packard, 1501 Page Mill Road, Palo Alto, CA 94304. **In Europe:** Hewlett-Packard S.A., 7, rue du Bois-du-Lan, P.O. Box, CH 1217 Meyrin 2, Geneva, Switzerland. **In Japan:** Yokogawa-Hewlett-Packard Ltd., 29-21, Takaido-Higashi 3-chome, Suginami-ku, Tokyo 168.

02-5952-7647

PRINTED IN U.S.A.