

## EXTERNALLY DRIVING THE 202A LOW FREQUENCY FUNCTION GENERATOR

### GENERAL

The Model 202A Low Frequency Function Generator has been used for some time as a high stability multi-purpose source of transient-free voltages. Thus, it is particularly useful for testing low frequency equipment and for the electrical simulation of mechanical phenomena. In addition the 202A can be adapted for single cycle operation.

### ADVANTAGES OF SINGLE CYCLE OPERATION

The ability to produce a single cycle from the 202A Low Frequency Function Generator permits its use as a source for observing the transient response of networks and systems rather than being limited to observations of steady state characteristics.

### METHOD

The method for single cycle operation consists of triggering the 202A circuit externally with single pulse which initiates one cycle of 202A operation. The only additional equipment required is an external single pulse source, a 185 volt source (or a potentiometer) and a diode.

### DESCRIPTION

A. An diode, 212-G11A, and a 185 vdc supply are inserted between the grid (pin 2) of V-17A (12AU7) and the B- buss in the 202A as shown by the dotted lines in Figure 5. The purpose of the diode is to keep the integrator from charging too high. The 185 volts may be easily supplied by inserting a 200K ohm potentiometer between B+ and B-, e.g. pin 1 of V-5 (OA2) and pin 2 of V-6 (OA3), as shown by the dotted lines in Figure 6 and adjusting the output for the proper voltage. The 185 volts should be established prior to the insertion of the diode to avoid exceeding the maximum back voltage of the 212-G11A (75 vdc).

If you prefer you may omit the potentiometer and insert a 185 volt power supply or battery between the terminals A-B shown in Figure 5.

B. Either capacitor C-10 or C-13 should be open-circuited from the plate of V-3 (6AL5). A negative pulse of at least 3 microseconds duration and 6 volts amplitude applied between the capacitor and B- will drive the 202A generating circuits. With the signal applied to C-10, the output will be a negative cycle; whereas, if the driving signal is applied to C-13, the output is a positive cycle.

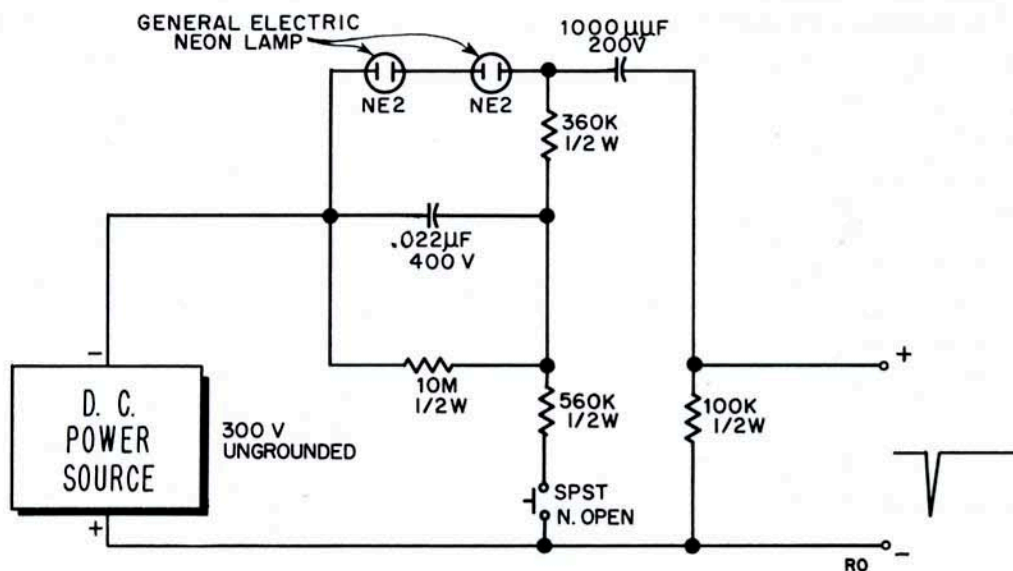

Figure 1

### PULSE FORMING CIRCUIT

If a pulse generator is not available, the circuit shown in Figure 1, illustrates a simple method of generating a fast rising single pulse of sufficient amplitude and duration to drive the 202A Low Frequency Function Generator.

The use of the 0.022  $\mu\text{f}$  capacitor provides a 10 millisecond "guard" interval during which time switch contact bounce will not generate undesired trigger pulses. Figure 2 shows an output pulse as generated by this circuit.

### OPERATION

Figures 3 and 4 indicate the output of the 202A Low Frequency Function Generator operating under normal conditions and when modified for single-drive operation. Generation of the single output wave was initiated by a trigger pulse from the pulse forming circuit shown in Figure 1.

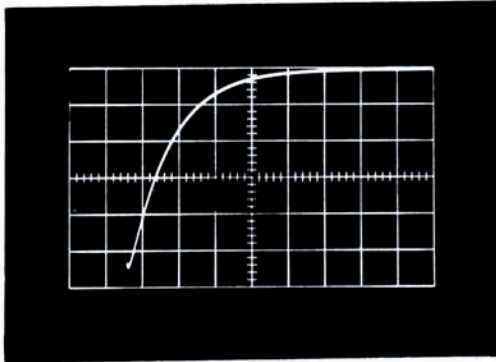

Figure 2. Negative going pulse  
Sweep time: 0.1 millisecc/cm  
Amplitude: 5 v/cm  
Presentation: Positive ac up

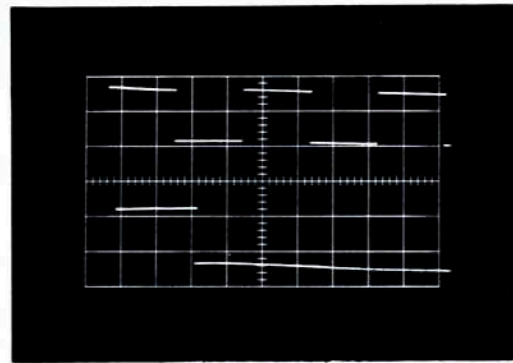

Figure 3. Single cycle square wave output.  
Driving trigger pulse applied to C13.  
Sweep time - 2.0 seconds/cm  
Amplitude - 5.0 volts/cm  
Presentation - Positive dc up

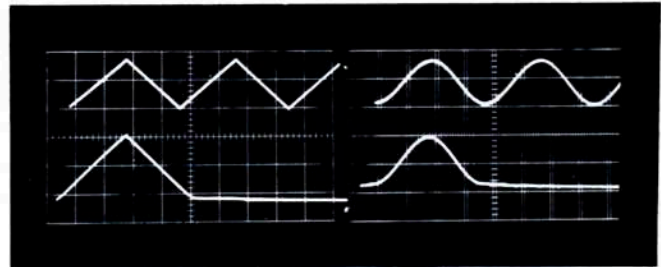
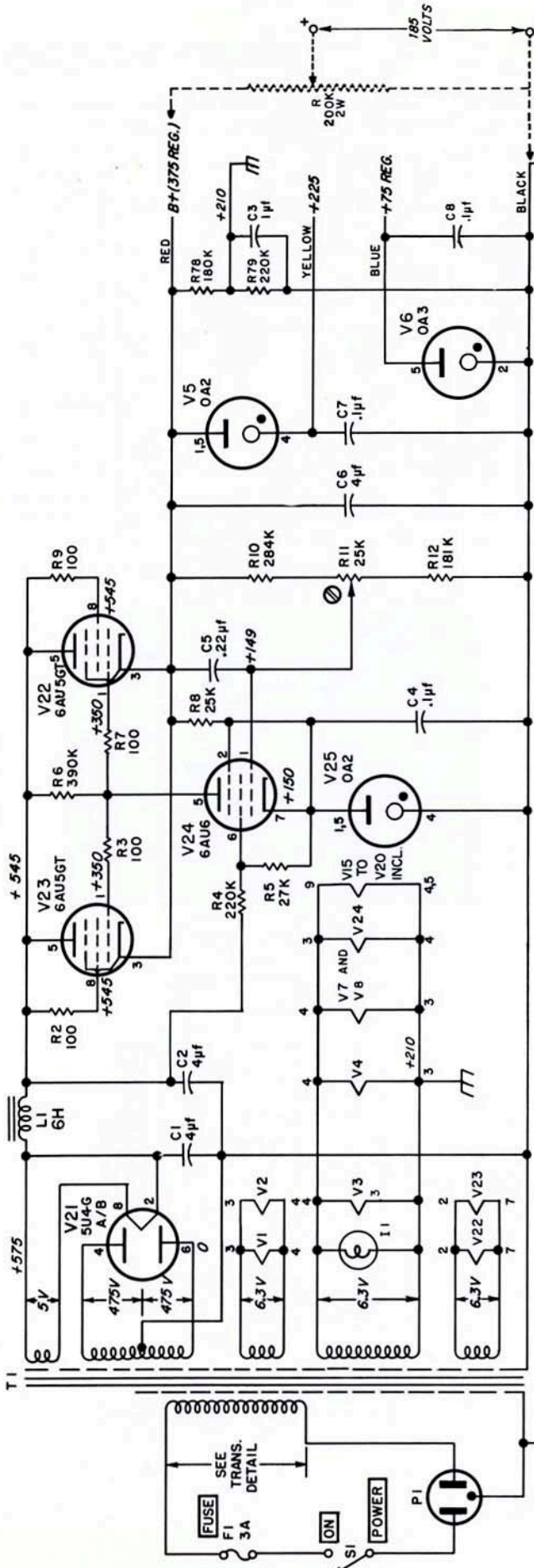

Figure 4. Single cycle triangular and sinusoidal output waves.  
Driving trigger pulse applied to C-13.  
Sweep time: 2.0 seconds/cm  
Amplitude: 5.0 volts/cm  
Presentation: Positive ac up





NOTES: (APPLY TO FUNCTION GENERATOR & AMPLIFIER SECTION AS WELL AS TO POWER SUPPLY SECTION).

CONDITIONS OF DC VOLTAGE MEASUREMENT:

1. 115/230V, 50/1000~ POWER SUPPLY
2. MEASURED BETWEEN THE INDICATED POINTS AND B- WITH A VOLTMETER OF 122MEG OHMS INPUT RESISTANCE. (B- IS ANY BLACK LEAD IN POWER SUPPLY EXCEPT T1 PRIMARY START.)
3. PANEL CONTROLS SET AS FOLLOWS:  
 RANGE AT X10.  
 FREQUENCY AT 5.  
 FUNCTION AT SINE.  
 AMPLITUDE AT MAX.

K = 1000 OHMS  
 M = 1 MEG OHM

↗ MAIN (EXTERNAL) CHASSIS, ISOLATED FROM POWER SUPPLY VOLTAGES.

↖ INTERNAL CHASSIS, ONE POINT CONNECTION TO DIVIDER R78 & R79

⚡ (POWER SUPPLY RETURN) IS NOT CONNECTED TO CHASSIS.

CAPACITY IN  $\mu$ JF UNLESS OTHERWISE NOTED.  
 202A - PS - 5311A

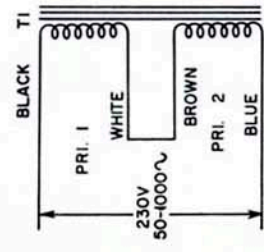
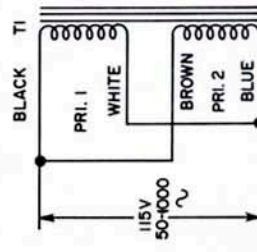

TRANSFORMER DETAIL

Figure 6