

APPLICATION NOTE 289

A Stimulus For Automatic Test

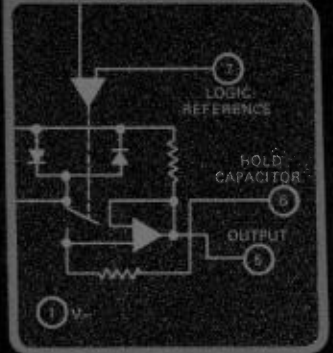
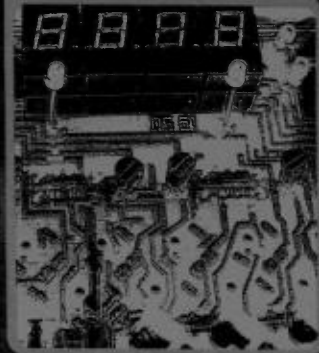

The 8165A programmable signal source as a cost effective solution.

HEWLETT  PACKARD

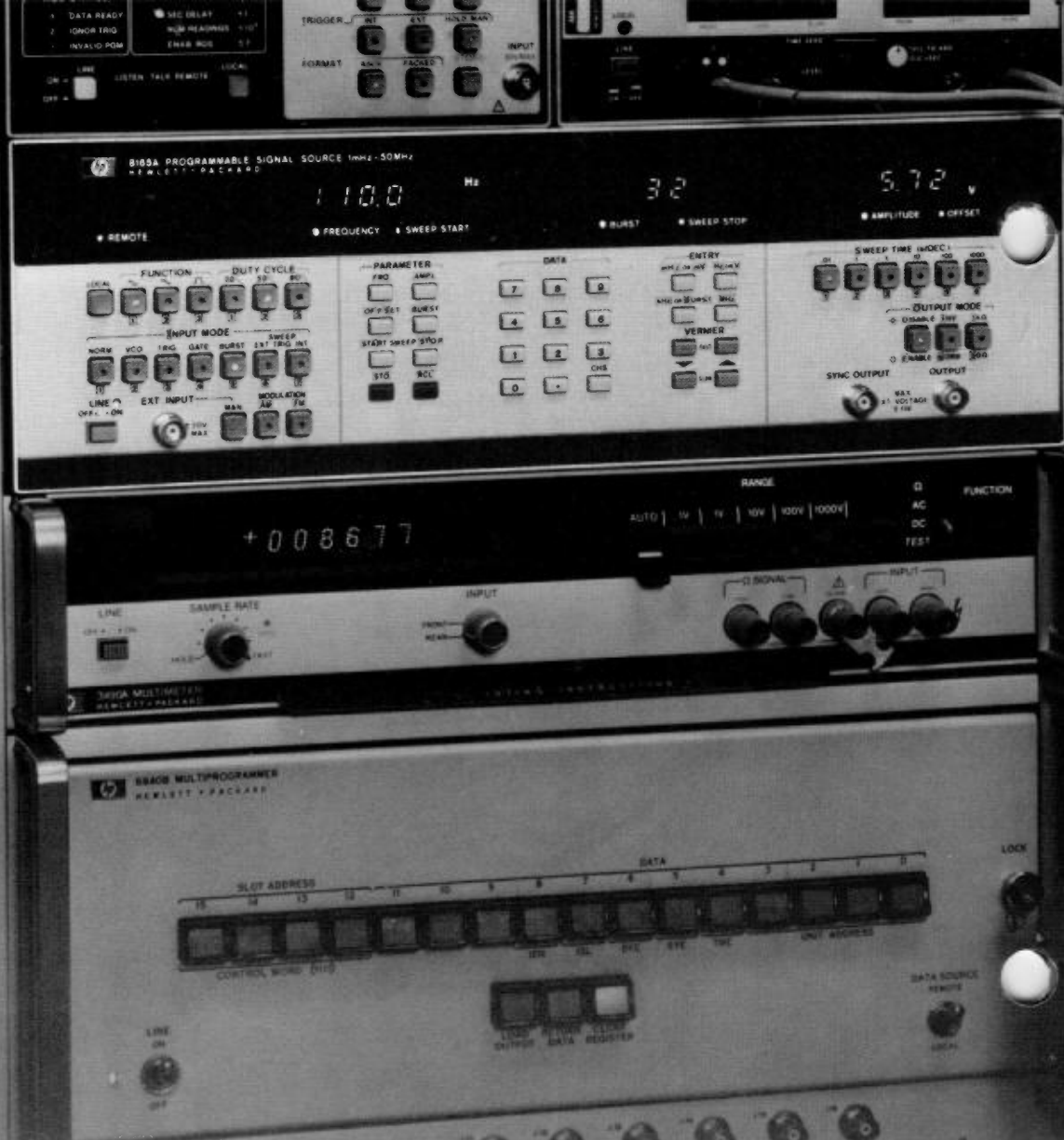

Contents

Introduction	3
Research for tomorrow's auto: Electrically-controlled combustion	4
Preparatory investigations for the Galileo Mission: Helium detector uses opto-electronics	6
Train receiver test for rail traffic control system	8
Automatic test for radar sample-and-hold amplifier	10
Appendix: Main 8165A capabilities	11

Introduction

Instead of investing in a range of dedicated instruments, a single source giving a choice of waveforms and operating modes can save you time, money and space. Later extensions to your bench or system test capability can often be carried out with a minimum of outlay.

Modern sources must provide good accuracy, clear displays and automatic error detection. This makes output monitoring redundant and you no longer have to tie up valuable scopes and voltmeters just to see if the source is correctly programmed.

Intelligent instruments, incorporating a microprocessor, are easy to program, straightforward to integrate into HP-IB* systems. High accuracy and intelligence eliminates software correction loops.

In embodying these features, the Hewlett-Packard Model 8165A Programmable Signal Source provides a high degree of flexibility at an affordable price. In the following pages, automotive and space research projects are presented in which the 8165A's adaptability and cost-effectiveness were exploited. In all examples, instrument intelligence, non-volatile memory and easy programmability contributed to rapid system integration and were among the features which led to the choice of this instrument.

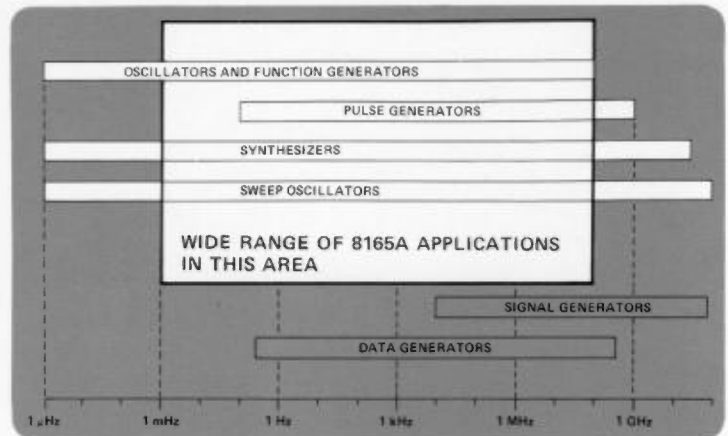

HP's sources cover a wide spectrum from dc to SHF. The 8165A finds application in areas where function, pulse and synthesizer features with trigger capabilities are required.

* Hewlett-Packard Interface Bus (HP-IB) — a versatile interconnect system for instruments and controllers. This is Hewlett-Packard's implementation of IEEE Std. 488-1975 "Standard Digital Interface for Programmable Instrumentation".

Research for tomorrow's autos: Electronically controlled combustion



A project was recently undertaken at a laboratory of the German autoelectric industry to develop and test an 'intelligent' electronic controller for the internal combustion engine. Functions specifically allocated for control were ignition and injection timing, injection duration, engine speed, and generation of speed-related switching pulses for automatic gearboxes. In addition, general monitor functions — such as oil pressure and water temperature — were to be carried out by the engine controller.

When operational, the engine controller would receive status information from a transducer located at the flywheel. Resulting controller action must then be synchronized, within a very small tolerance, to crankshaft rotation. Due to the finite time required for transducer signal transmission and subsequent controller response, this critical sync tolerance could be adversely affected. For this reason, a high resolution transducer capable of generating 3600 pulses per complete turn of the crankshaft was necessary in the development and test phase of the project. Production models, it was planned, would incorporate a unit of lower resolution.

Since reaching prototype stage, an HP-IB test system has been built for simulating the combustion engine and processing the collected measurement data in order to investigate engine controller performance. The transducer pulses are simulated using an 8165A Programmable Signal Source, criteria being programmability, high accuracy,

high frequency stability and the ability to change frequency rapidly.

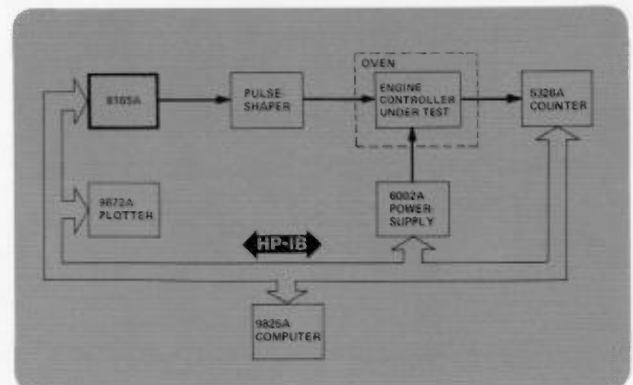

Figure 1. Discrete speed simulation by HP-IB programming

In the first test performed by the system, the control unit's behaviour under constant, then varying, speed was investigated. The system was configured as shown in Figure 1, the 8165A frequency (speed analog) being programmed directly via the HP-IB interface. Selected frequencies within the 1 kHz to 500 kHz range (corresponding to crankshaft speeds of 18 to 8400 rpm and 0.1° transducer resolution) were programmed. Then, for each frequency, the ignition timing, injection timing and injection duration generated by the control unit were measured. Because the control unit must function in temperatures ranging from -40°C to +130°C, this whole procedure was repeated for different controller environment temperatures.

Using the same setup, the controller's response under different speeds and temperatures was evaluated by plotting the computed ignition timing against simulated speed (Figure 2). To avoid lag and overshoot effects in the controller, the 8165A frequency was changed gradually. These curves are valuable for adjusting the controller so that the exhaust, consumption and power of individual engine types can be optimized.

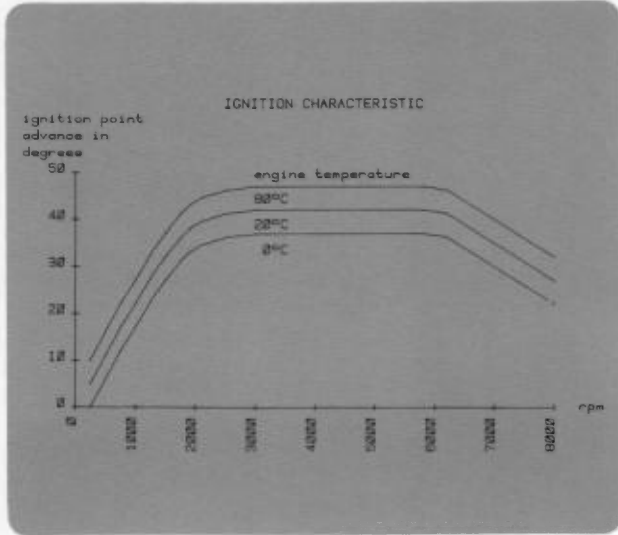

Figure 2. Engine controller response

The second test measured the controller's response to certain engine speed limits (e.g. safe maximum speed to avoid engine damage, and upper/lower switching tolerances for automatic gearboxes). The system (Figure 3) used the 8165A to simulate a continuous, linear speed change. A programmable D/A converter supplied the external voltage necessary for VCO operation. The VCO characteristic was linearized to 0.5% by software. Utilizing this precise characteristic, the 8165A frequency was changed until the control unit generated the trigger pulse under investigation. The exact 8165A frequency was then measured with the 5328A counter.

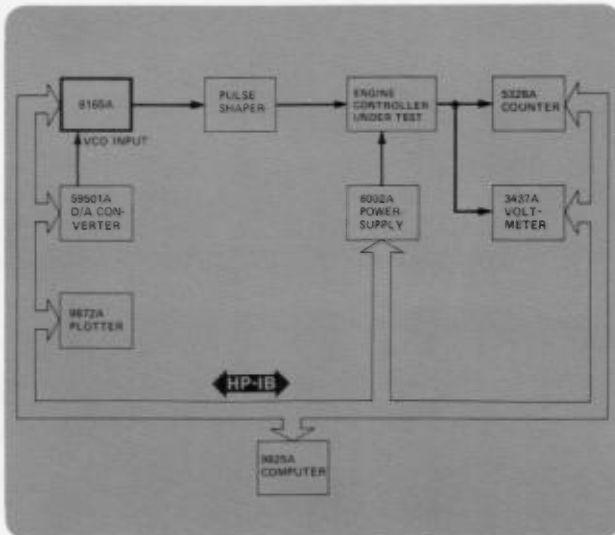

Figure 3. Continuous speed change in VCO mode

In the third test, the controller's reaction to fast speed changes (such as the speed-drop caused during gear changing), and its ability to initiate engine speed changes at precisely-defined times (e.g. between two ignition pulses) were investigated. Again, the system configuration shown in Figure 3 was used with the 8165A in the VCO mode. In this mode, an input voltage jump causes an extremely fast frequency change which is ideal for worst case testing and offers the advantage of high repeatability.

The time-span from the ignition pulse to the frequency drop (Figure 4) is divided into 5 distinct time intervals: counter measuring time, transfer time (counter-controller), controller time, software delay (variable), and D/A converter programming time. Because four of these intervals are fixed and known, the software delay was introduced to arrive at a total which was both variable and accurately measurable. The test objective of determining controller response to precisely defined reductions of speed could therefore be achieved.

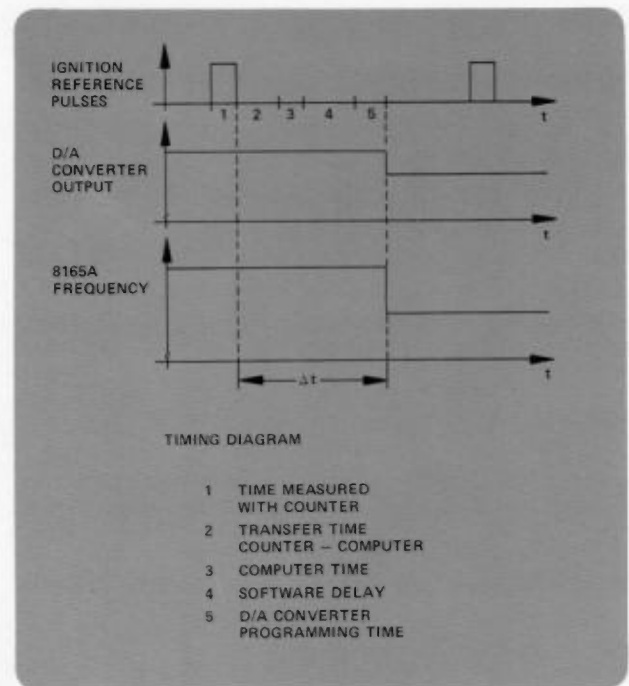
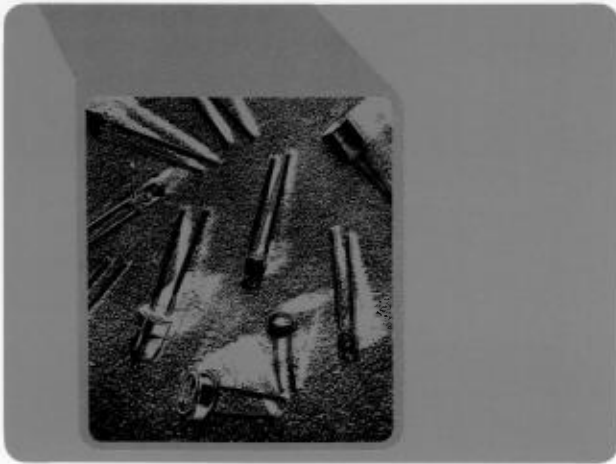

Figure 4. Speed cut-back must occur within the ignition pulse period

According to the researchers, the necessary test time for such a complex controller could be reduced by factor 10 when employing this system. Furthermore, the system enabled tests to be performed economically which previously required an unjustifiably high time and hardware investment. The benefits of such a system could therefore be measured both in terms of a better end product and current cost saving.

Preparatory investigations for the Galileo mission: Helium detector uses opto-electronics

* Prof. Dr. von Zahn, University of Bonn, is managing the investigation. Practical tests are carried out at the Hahn-Meitner Institute of West Berlin by Dr. D. Bräunig, F. Wulf, Dr. W. Gaebler.



In January 1982, the USA will launch a probe to explore Jupiter's atmosphere. One of the on-board investigations will concern helium abundance, measurements being made with an interferometer using opto-semiconductor diodes.

As the probe is expected to encounter high-energy particles which would cause behavioral change to the opto-diodes, error approximations must be determined beforehand so that valid measurements can be made during the actual mission. With this objective, the nature and degree of change to opto-diodes under radiation is being investigated. *

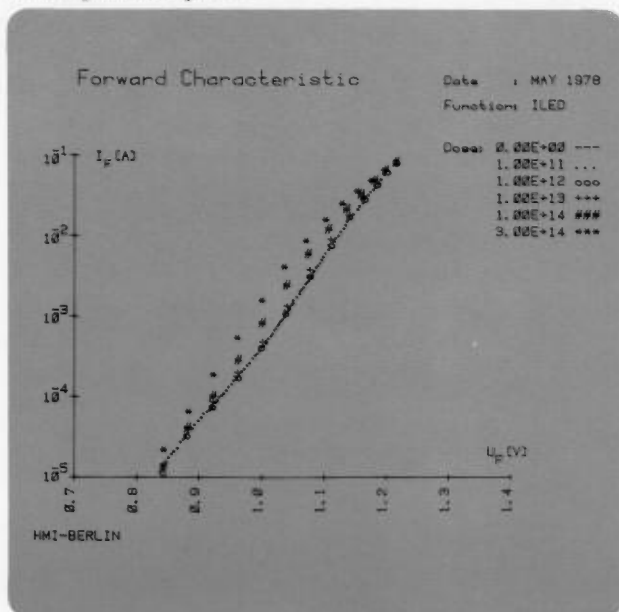

Figure 1.

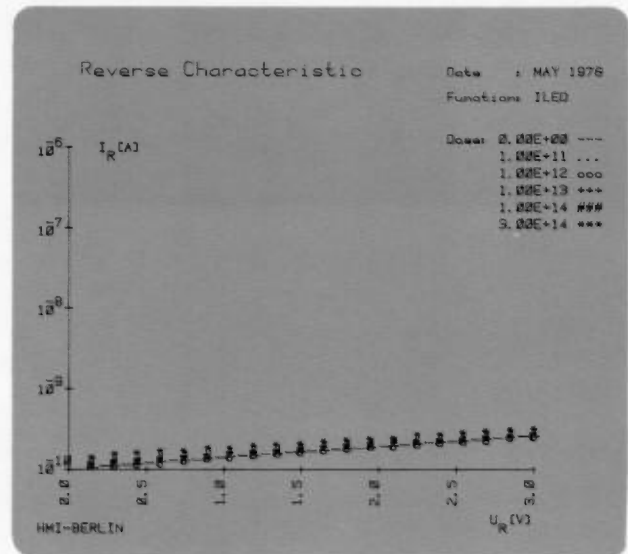

Figure 2.

Figures 1, 2 and 3 show some current results of the investigation where diode characteristics were measured before and after exposure to a specific radiation dose. Figure 1 shows a family of forward characteristics for a single diode at increasing doses (the dotted line on the plot relates to measurements made before irradiation, the other symbols to measurements on the same diode made after successive doses). Reverse characteristics are shown in Figure 2. By showing the varying post-radiation/pre-radiation light emission ratios I_{LR}/I_{L0} of six test diodes for different radiation doses, Figure 3 provides a behavioral pattern spread.

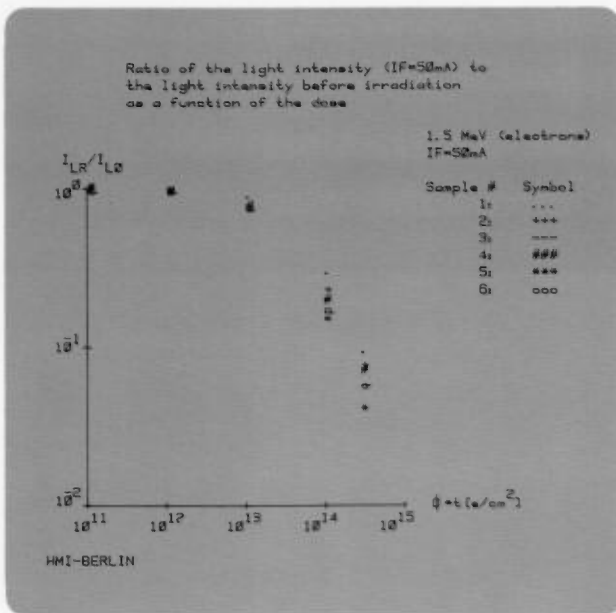

Figure 3.

Because of the numerous measurements to be performed on different semiconductor devices, a test system (Figure 4) was built up using two different interface buses: the HP-IB for programming the measurement, test and plotting instruments, and a 16-bit parallel bus for peripheral devices and the multiprogrammer. This brought maximum automation with a wide range of instrumentation, thus enabling fast repetitive test runs. The stimulus employed for dynamic LED testing was the 8165A

Programmable Signal Source, whose pulse transition times of less than 5 ns allowed easy measurement of the optical LED rise- and falltimes. Other requirements for the LED test signal were 150 mA current amplitude, 1 kHz repetition rate, and 20% duty cycle – all of which could be accomplished via simple 8165A software commands.

Due to the varying characteristics of the tested LED's an interactive adjustment loop was written into the 8165A software to guarantee a precise 150 mA current pulse for every test sample; the current flowing through the LED being measured using a precision resistor and the HP 3437A System Voltmeter. LED light pulse transition times were then measured using a fast photo diode and the HP 5363A Time Interval Probes together with the HP 5345A Counter. Because LED transition times change depending on the radiation dose, they provide an additional means of accurately plotting dynamic LED behaviour.

System choice was governed by flexible capability for future test and research needs. Among the envisaged tasks are automatic op amp tests, where Bode plots and slew rate measurements will be made using the 8165A as stimulus.

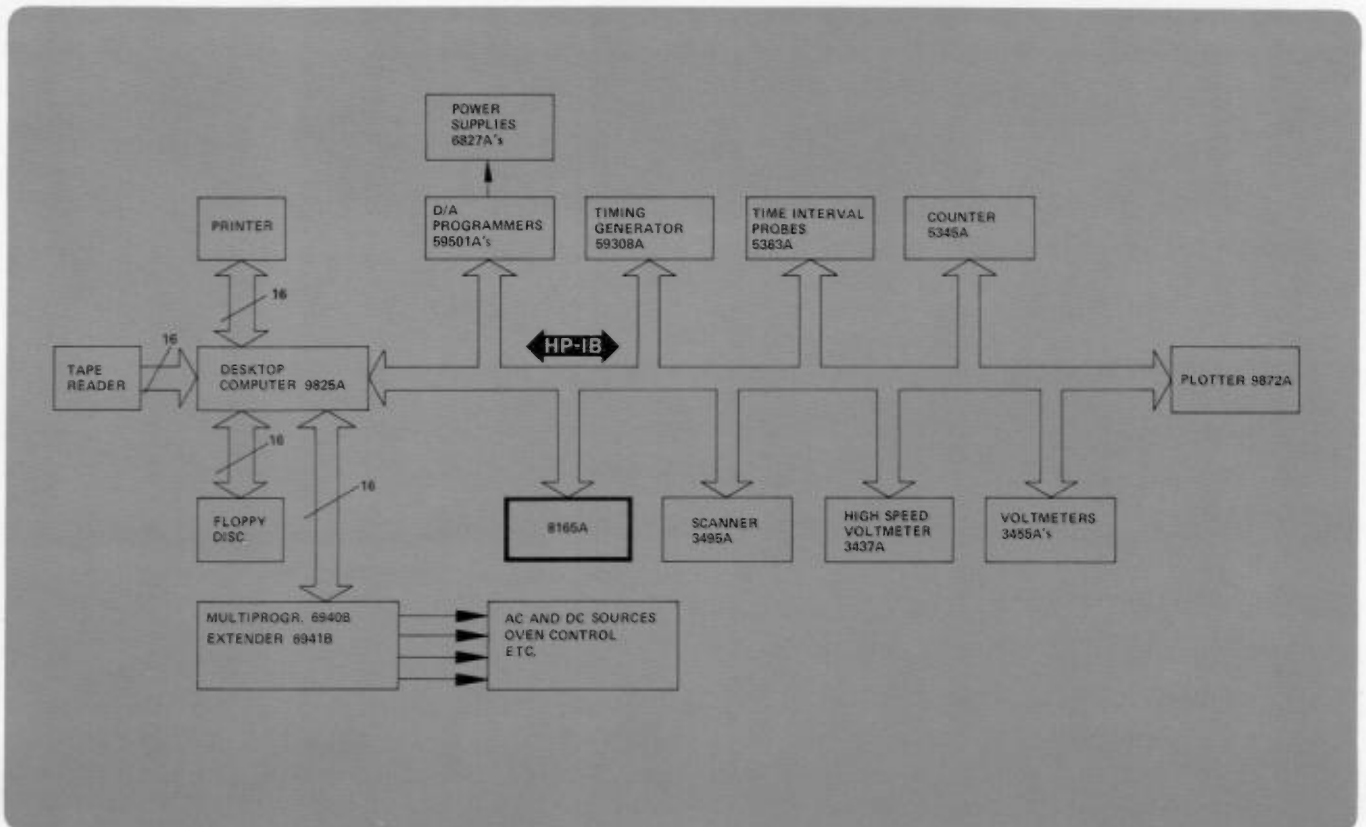
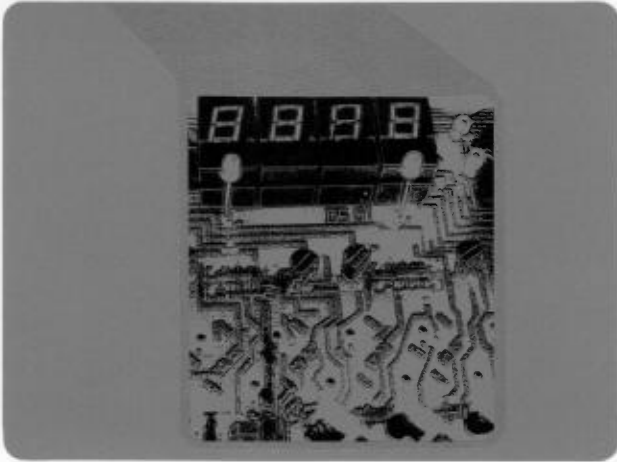

Figure 4. Test setup for opto-semiconductors

Train receiver test for rail traffic control system



Today's demands on city rail traffic require a fast, failsafe control system which optimizes the speed and efficiency of the network. A significant contribution in the further elimination of the human error element is represented by the new train control system being introduced on a city railway.

At key positions on the underground network, transmitters will be installed which transmit coded route information. Unique data from individual transmitters will make precise train positioning possible. Each train will carry an "intelligent" receiver, in which the train's route is pre-programmed. The received signals will be decoded and compared with the stored information. If no equivalence is detected, an alarm will be actuated in the driver's cab and, in an emergency, braking will occur.

The transmitted signal consists of sine-wave bursts. Transmitters are identified by the number of cycles per burst and the time interval between bursts (Figure 1).

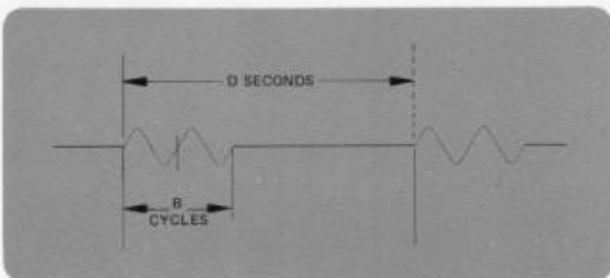

Figure 1. Signal from the trackside transmitter

A British company had the task to develop an automatic system for testing the receiver. In the system, a means had to be found to simulate typical transmitter signals and to measure the response. These sine-wave bursts were conveniently generated with the 8165A Programmable Signal Source, utilizing its counted burst capability.

Using just a few easy commands, the exact waveforms of all possible transmitter signals were programmed on the 8165A. Input mode (burst), sine wave, frequency, amplitude and offset programming is exemplified by the statement:

```
wrt 716 "I5 F1 FRQ 3 KHz  
AMPL 2 V OFS 0 V"
```

(the example uses Model 9825A Desktop Computer syntax. 716 is the 8165A's HP-IB address). Output modes (enable/disable output, normal/invert, 50 Ω / 1 k Ω output impedance) are typically programmed as follows:

```
wrt "OE ON 05" (Enable, Normal, 50  $\Omega$ ).
```

Burst length is programmed in terms of the number of cycles per burst as in the following example:

```
wrt 716 "BUR 5 BT" (for a burst of 5 cycles).
```

The foregoing give together one 'set' of operating parameters. When a number of sets are needed repeatedly, they may be stored in the 8165A's non-volatile memory by the statement:

```
wrt 716 "STOn" (where n is an integer 0-9  
and allows up to 10 sets to be stored).
```

The recall capability can then bring back a complete set of parameters with the single command:

wrt 716 "RCL n"

This saves system controller time and also means fast manual testing in repetitive situations.

The bursts were triggered via HP-IB with the burst repetition rate determined by a software wait loop. In addition to taking the controller's minimum and maximum wait times and execution time into consideration, the loop also ensured that the wait time (D seconds) was greater than the burst duration (B/C seconds). Each pass through the loop generates the trigger.

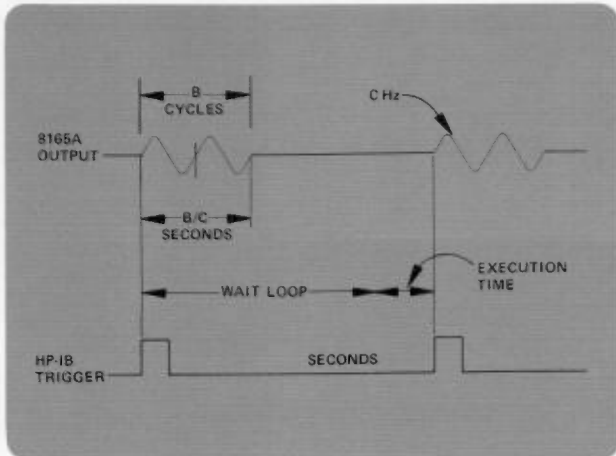

Figure 2. Parameters for programming a test signal burst

The following block diagram (Figure 3) shows the general test setup.

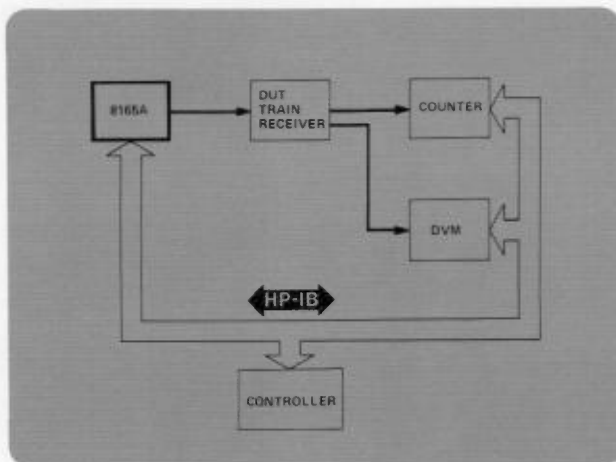

Figure 3. Test setup for train receiver

Counted burst mode with the ability to trigger bursts from the HP-IB were fundamental to this test. Additional grounds for choosing the 8165A were its easy programmability and many features. These contributed to easy system integration and ensured general applicability to many current and future stimulus needs. Requiring no instrumentation to monitor its output, the 8165A gained rapid acceptance in terms of precision and convenience.

Programming example

The following example illustrates the 8165A's easy programmability. The program is based on the train receiver's requirements, but is not part of the test system's software. The HP 9825A Desktop Computer is used as controller and triggers the 8165A via HP-IB to output a burst.

Required burst length (cycles) and frequency (kHz) are entered (see Dialog) and stored in registers B and C (see Listing). The 9825A then calculates the minimum burst spacing (see Dialog "delta time between bursts must be > ms") for the given conditions (i.e. $B \times 1/C$). To accommodate the 9825A's minimum wait time, the program automatically provides a lower limit of 3.5 ms to this value. The dialog is continued by entering the desired burst spacing (D ms) which must lie between the minimum delta time printed out and the 9825A's maximum wait time of 32 767 ms.

SINE-WAVE BURST

= Manual entry

BURST LENGTH

Press CONTINUE

FREQUENCY in kHz

Press CONTINUE

DELTA TIME BETWEEN BURSTS MUST BE >

3.500 MS

DELTA TIME IN MS

Dialog

The program deducts 2.7 ms from the value entered to allow for the 9825A's execution time, and then proceeds to a loop (program lines 21, 22) where the 8165A is triggered at each re-entry. Note that, to simplify changing the 8165A's address, the value is stored in register A.

```

01: prt "SINE-          11: 1/C+C
WAVE BURST":          12: C*B+C
SPC                    13: if C<3.51
14: wrt A:"F1150F     14: prt "DELTA
S&VAMP2VON050E"      TIME BETWEEN
34: enr "BURST        BURSTS MUST
LENGTH">B             BE >
4: fxd 0              15: fwt 1+(13.31
5: spc                " MS"
6: wrt A:"BUR":       16: wrt 16.1+C
B;"BT"                17: spc
7: enr "FREQUENC      18: enr "DELTA
Y in kHz",C           TIME IN MS":D
8: fxd 3              19: spc 2
9: spc                20: D-2.7+D
10: wrt A:"FRQ":      21: trs A:wait 0
C;"KHZ"               22: sto 21

```

Program Listing

Automatic test for radar sample-and-hold amplifier

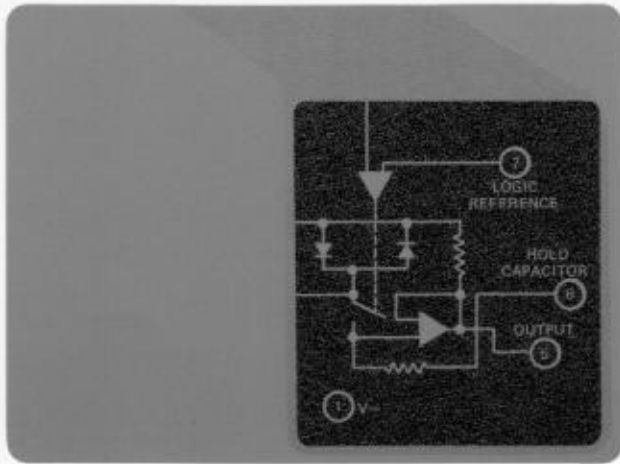

Radar continues to play a critical role in defense and air traffic control: low down times and fast module exchange and repair are essential to retain credibility. An English company has contributed to rapid module repair by developing a new automatic test complex for radar sub-assemblies. The system uses an HP 1000 Computer and, as stimulus, an 8165A.

One of the sub-assemblies tested is a fast sample-and-hold (S+H) amplifier. Two tests are performed, one for the sample capability, the second for the hold capability.

Sample capability is verified by measuring the bandwidth. The S+H amplifier is operated in the sample mode, and the 8165A is programmed to provide a continuous sinewave with the frequency changed step by step through the band of interest.

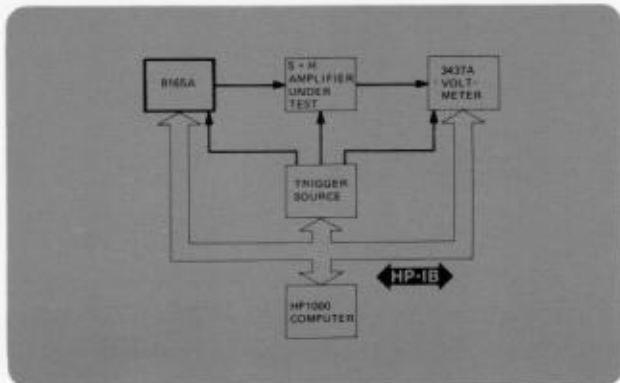

Figure 1. Setup for hold test

Hold capability test aim is to measure the output droop of the S+H amplifier in a $10 \mu\text{s}$ time interval. However, because the lag ($n \mu\text{s}$), caused by the 3437A High Speed Voltmeter's conversion time and the HP-IB handling routine is of the order of $200 \mu\text{s}$, the two amplitude measurements cannot be made within the required $10 \mu\text{s}$. Consequently, as shown in the Timing Diagram (Figure 2), a sampling method is used and the measurements are made on two consecutive cycles.

The custom designed HP-IB programmable trigger source determines the timing for the test. To achieve the required $2 \mu\text{s}$ pulse width, the 8165A is operated in squarewave with a frequency of 250 kHz ($4 \mu\text{s}$ period) and external trigger mode. Offset is programmed so that the waveform baseline is at zero volts. The first $2 \mu\text{s}$ pulse is triggered and, after the necessary acquisition time, the S+H amplifier will be switched to hold. After another delay for the hold settling time, the 3437A Voltmeter is triggered and the digital readout is transferred to the computer. The voltmeter trigger for the second cycle is arranged to be $t_s + 10 \mu\text{s}$, where t_s is the cycle period ($> n \mu\text{s}$). With these two amplitude values (A_1 and A_2) and the effective $10 \mu\text{s}$ time interval, the droop rate is calculated.

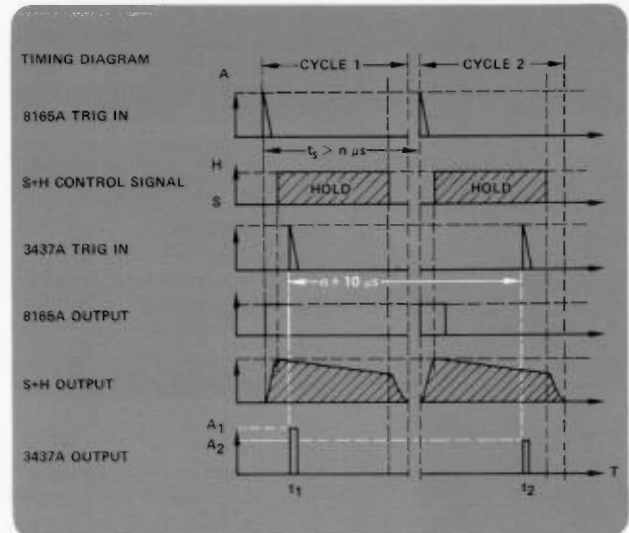

Figure 2. Sampling technique is used

This test demands high pulse quality with fast 5 ns transition times, small overshoot and ringing, short settling time and external trigger capability. An additional ground for using the 8165A was the choice of pulse/function outputs for other system applications. Furthermore, the need for an accurate system reference was met by the stability and resolution of the 8165A's frequency.

Appendix: Main 8165A capabilities



8165A Option 002 Sweep with AM

The 8165A Programmable Signal Source generates precision sines, square waves, pulses, ramps and triangles. Crystal reference provides a frequency accuracy of 0.001% across the entire 0.001 Hz to 50 MHz range.

Its variable 20 V_{pp} amplitude and clean, 5 ns transition time pulses are perfect for digital applications. Amplitude and offset are programmable with 2% accuracy to 5 MHz.

External trigger, synchronous gate, counted burst, VCO, FM and optional sweep modes and AM provide the flexibility to use the 8165A in many different applications. The source impedance is 50 Ω / 1 kΩ selectable and the output may be disabled, inverted or operated in dc mode. All specifications are guaranteed from 0 to 50°C for full confidence in system applications.

Microprocessor control sets new standards in operator convenience. Keyboard and LED's, together with the instrument's high accuracy, allow direct entry and display of desired waveform parameters.

In systems, the intelligent 8165A cuts software development costs and computer time. Key-stroke programming means identical control sequences for front panel and bus-entered commands. Programming mnemonics for all keys are indicated on the front panel. Error detection and a learn mode are also provided.

Refer to instrument data sheet 5952-9520 for complete specifications.

The 8165A stores parameters for 10 complete waveforms. An entire waveform is stored or subsequently recalled simply by pressing two front panel keys or by a single program step. Batteries provide power-off storage of all parameters for up to four weeks.

8165A Main Specifications

Frequency	1 mHz – 50 MHz
Output into 50 Ω	20 V _{pp}
Offset into 50 Ω	± 10 V
Selectable Z _s	50 Ω / 1 kΩ
Sine wave	up to 50 MHz
Square wave	up to 50 MHz
Triangles	up to 50 MHz
Ramp	20%, 80% symmetry up to 20 MHz
Haversine, havertriangle, (special)	50% symmetry up to 50 MHz 20%, 80% symmetry up to 20 MHz
Pulse:	20%, 80% duty cycle up to 20 MHz
Transition times	5 ns fixed
Ext. trigger	•
Gate	•
Burst	9999 cycles
VCO	3 decades
FM	± 1 % deviation
AM (Option 002)	0–100%, all waveforms
Sweep (Option 002)	3 decades
Programmability	HP-IB (all modes and parameters)



For more information, call your local HP Sales Office or East (301) 948-63 70 · Midwest (312) 255-98 00 · South (404) 955-15 00 · West (213) 877-12 82.
Or write: Hewlett-Packard, 1501 Page Mill Road, Palo Alto, California 94304. In Europe: Hewlett-Packard SA, P. O. Box, CH 1217 Meyrin 2, Geneva, Switzerland.
In Japan: Yokogawa-Hewlett-Packard Ltd., 29-21 Takaido-Higashi 3-chome, Suginami-ku, Tokyo 168.

12-01
5952-9517

Published by Hewlett-Packard GmbH
Printed in the Federal Republic of Germany, 5/79