



APPLICATION NOTES

APPLICATION NOTE 28 DRIFT MEASUREMENTS ON HIGH STABILITY SIGNALS

GENERAL

The introduction of the Model 560A Digital Recorder has greatly enhanced the value of frequency count-

ing equipment for drift measurements, because the 560A analog output feature provides an automatic, instantaneous record of signal drift.

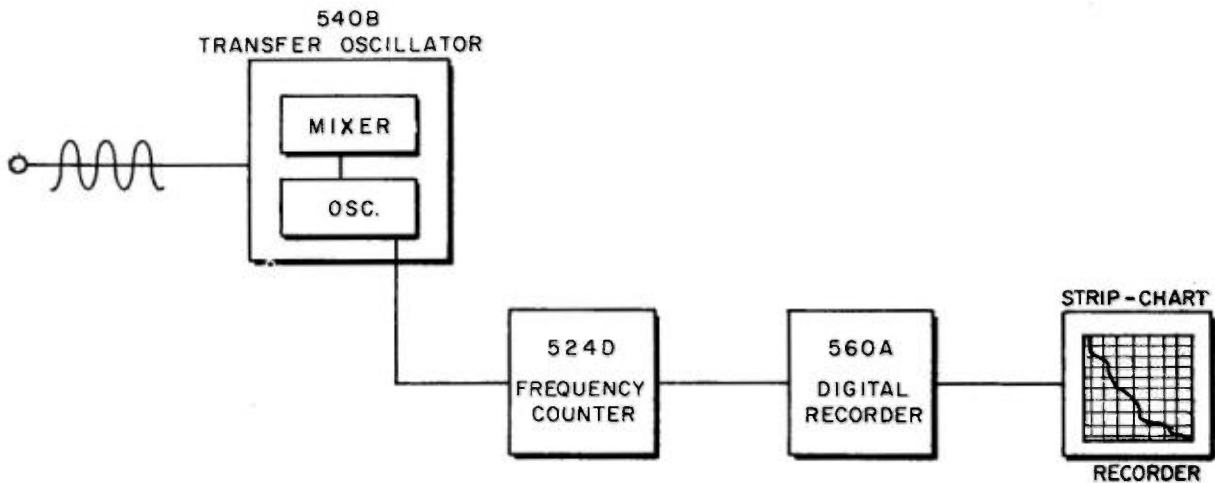

RO

The drift record above includes the signal drift and the 540 drift. 540 drift is usually so much smaller than signal drift however, that it can be neglected. When it can not, the system below

makes it possible to measure signal drift even when the signal stability is equal to or greater than 540 oscillator stability (approximately 2 parts 10^5 per minute).

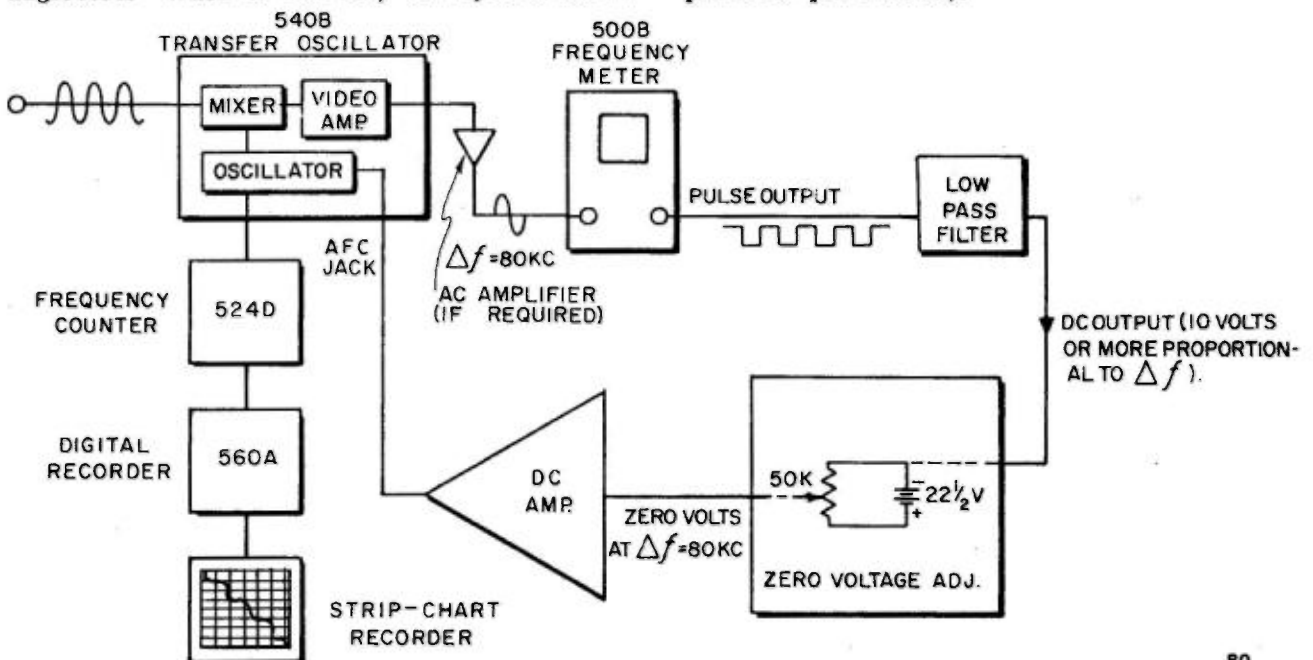

RO

CALIBRATION

1. Apply signal to 540A input.
2. Open feed back loop at dc amplifier input.
3. Ground the input to the amplifier.
4. Establish difference frequency of 80 kc (or any value less than 100 kc) by tuning the 540A Oscillator to the high side of zero beat. At 80 kc a negative voltage of 10 volts or more appears at filter output.
5. Adjust "zero voltage adjust" for zero volts at the amplifier input. (This permits a positive and a negative voltage output as the input and difference frequency drifts up and down respectively.)
6. Close loop at dc amplifier input.
7. Readjust 540A oscillator frequency if necessary.
8. Remove the ground connection from the input to the amplifier.

OPERATIONOscillator Drift

Any tendency for the 540A Oscillator to drift causes a change in the difference frequency which changes the dc voltage at the 540A afc jack and cancels the drift.

Carrier Drift

When the carrier drifts up or down, a positive or negative voltage will appear at the afc jack which will shift the oscillator frequency so that its harmonic increases or decreases correspondingly. Or, in other words so that the difference frequency will be constant.

Oscillator frequency change can then be measured and plotted with the 524B-560A¹.

RANGE

540A oscillator frequency control of approximately 0.1% is possible.

For example, with an oscillator frequency of 200 mc, the range is 0.1% (200 mc) or 0.2 mc.

At 10 kmc this corresponds to a carrier drift of $0.2 (50) = 10$ mc or 10 mc/10000 mc = 1000 ppm.

With a typical signal stability of 10 ppm/hr control would be possible for 100 hrs without changing 540A oscillator frequency.

EQUIPMENTDC-Amplifier -

Gain: between 100 and 500

The less drift the better - preferably chopper stabilized.

AC-amplifier ϕ 450A or equivalent. Not always required. Depends on 540B video amplifier output.

FILTER

Normally a one section RC filter with a cutoff frequency of from one to 10 cps will be sufficient. However, if it is desired to pass frequency modulation components and still suppress difference frequency components, a more elaborate filter can be constructed as described on page 4 of Application Note 1.

The actual input frequency will be the oscillator frequency times the harmonic number minus the 80 kc difference frequency. For example, with an oscillator frequency of 200.004 mc and a harmonic number of 20, the input frequency is $200.004(20) - .080 = 4000$ mc.