



APPLICATION NOTES

APPLICATION NOTE 27 BASIC MICROWAVE MEASUREMENTS

The field of microwave measurements can be conveniently divided into four general types: power, impedance, attenuation, and frequency. The versatility of Hewlett-Packard instruments permits you to make all of these measurements with a minimum of equipment. The four basic types of measurements are as follows: *

I. POWER MEASUREMENTS

Power measurements are considered more basic than voltage or current measurements at microwave frequencies, because power does not depend upon the position of measurement along a distributed type transmission line as voltage and current do.

The measurement of power is accomplished by means of a bolometer whose resistance changes with rf energy. The resistance change is measured in a bridge circuit such as the Model 430C Power Meter, and used to determine the rf energy.

Power measurements can be made on modulated as well as CW signals. In most cases where the modulation rate is high enough so the power meter does not attempt to follow the modulation envelope, the average power of the modulated signal will be indicated. Thus, one-half the peak power of square-waved carriers is displayed. In the case of sine-wave modulation the proper proportion of power to the CW level for the percentage modulation employed is displayed. For pulsed signals a power level proportional to the pulse width and repetition rate is shown.

There are two types of bolometers: barretters and thermistors. Barretters have a positive temperature coefficient of resistance (resistance increases with temperature increase) and thermistors have a negative temperature coefficient (resistance decreases with temperature increase). HP has mounted these bolometer elements so that when they are used in conjunction with the Model 430C, power delivered from both waveguide and coaxial systems can be measured.

For maximum convenience and versatility, HP has designed the following bolometer mounts for measuring rf power.

Model	Frequency Range	Characteristics
HP 475B Tunable Bolometer Mount	1000 to 4000 mc	Matches 50 ohm line to 100 or 200 ohms
HP 476A Universal Bolometer Mount	10 to 1000 mc	No tuning required. Swr less than 1.25
HP 477B Coaxial Thermistor Mount	10 to 10,000 mc	Broad band, low swr; no tuning
HP 485 Waveguide Detector Mount	2600 to 12,400 mc	Full coverage, tuned barretter mount
HP 487B Waveguide Thermistor Mount	4000 to 40,000 mc	Full coverage, no tuning, 1.5 swr G-X, 2 swr K-R

The Model 430C Power Meter has 5 power ranges 0.1, 0.3, 1.0, 3.0, and 10 milliwatts.

Power levels from 10 milliwatts to 10 watts can be measured with the Model 434A Calorimetric Power Meter which operates from dc to 12.4 kmc and does not require external bolometers.

Also, HP Directional Couplers and Attenuators can be used with the 430C and 434A Power Meters to measure power levels greater than 10 watts, as long as the maximum power limitations of the couplers and attenuators are not exceeded.

* Information on techniques for standards measurements is available in Application Note 21, Microwave Standards Prospectus.

W106

Up to 10 mw

10 mc to 10 kmc:

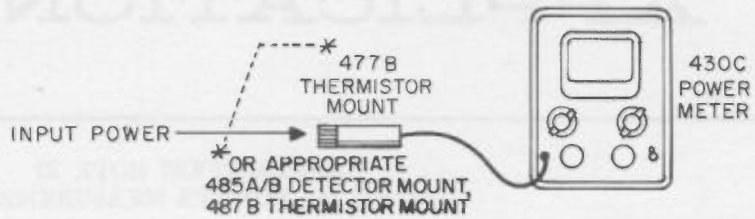

10 mw to 10 watts

dc to 12.4 kmc:

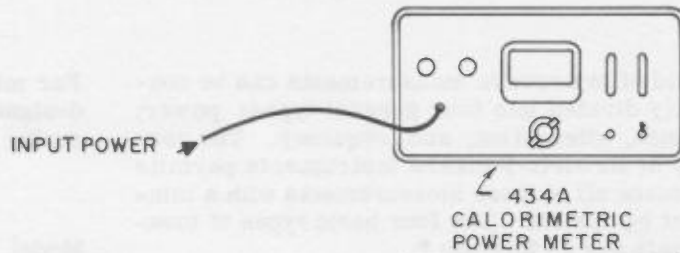

10 watts to 50 watts

216 mc to 4000 mc:

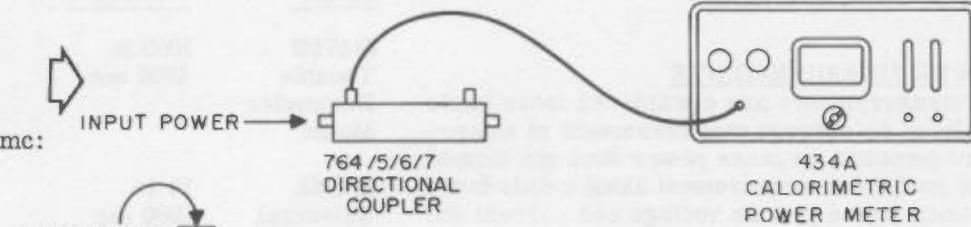

Up to 1 kw

2.6 to 12.4 kmc:

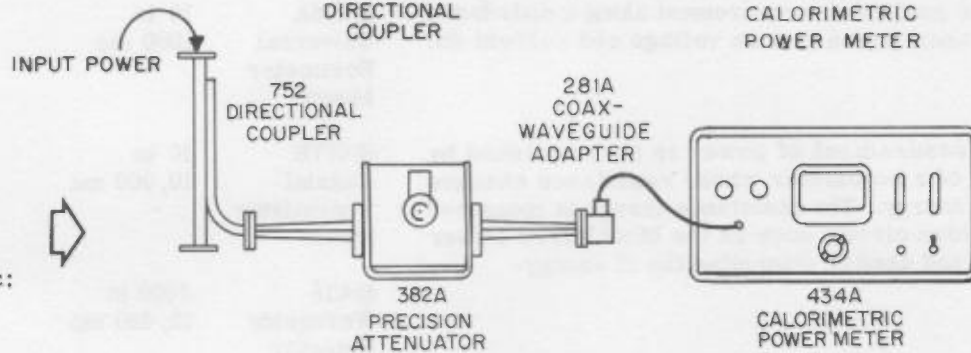

12.4 kmc to 40 kmc

Up to 10 mw:

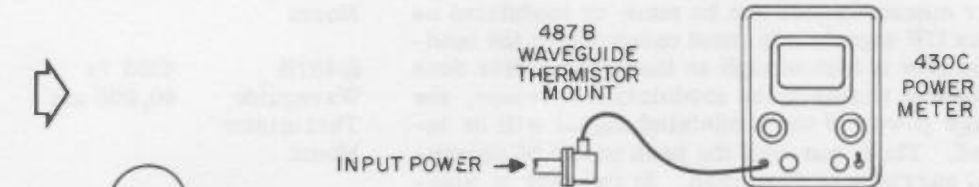

10 mw to 1 kw:

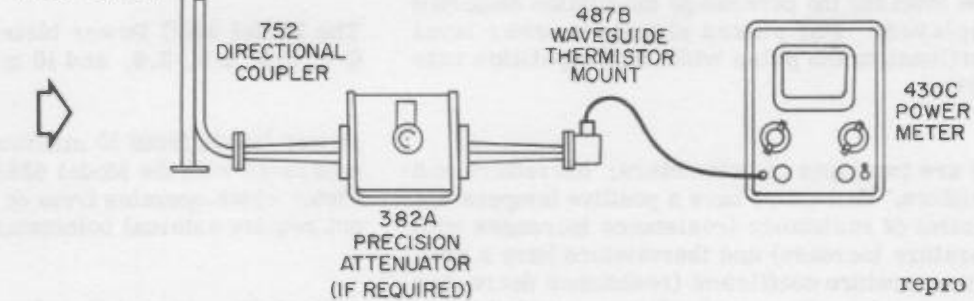

repro

Typical Power Measurement Systems

Figure 1

II. IMPEDANCE MEASUREMENTS

The measurement of impedance is perhaps the most frequent and most important measurement at microwave frequencies. Since impedance is a measure of reflected energy by the load, information concerning a load can be obtained if the reflection coefficient is determined.

There are two systems which can be used to quickly and conveniently evaluate reflection coefficients

and impedances; the slotted line system and the reflectometer system.

A. Slotted Line System

Magnitude and phase of the impedance of such devices as radomes and antennas can be obtained with a slotted line system.

A typical setup for making slotted line measurements is shown in Figure 2:

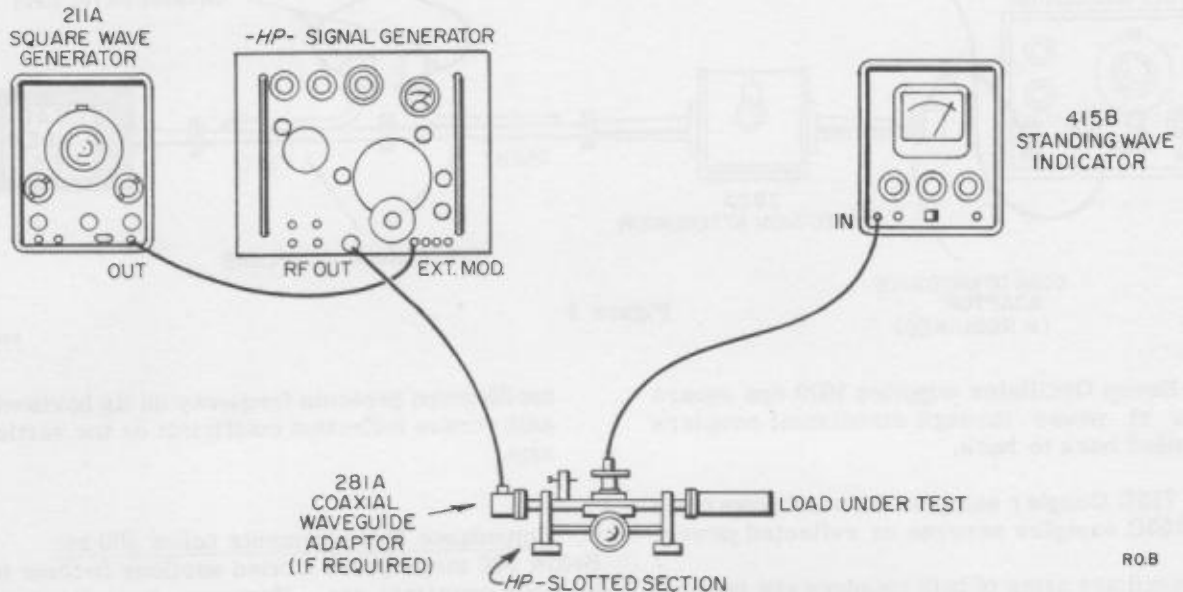

Figure 2

1. The standing wave voltage pattern is measured by means of a probe in a slotted section.
2. Detected probe output is connected to the Model 415B Standing Wave Indicator which measures the swr. The maximum and minimum positions of the probe are noted.
3. The load is replaced by a short circuit and the shift in the position of the minimum is recorded.
4. This data is entered on a Smith Chart from which the magnitude and phase of the reflection coefficient and impedance is determined.

B. Reflectometer Measurements

When phase information is not necessary, the reflectometer system is the easiest method for determining impedance for the following reasons:

The reflectometer setup saves engineering time by eliminating tedious swr measurements with slotted lines. Further, when driven by a swept oscillator, it makes possible direct and continuous oscilloscope or recorder presentation of reflection coefficient over a wide frequency range. The Model 416A Radio Meter automatically combines forward and reverse signals and displays their ratio directly irrespective of amplitude variations. A reflectometer setup is shown in Figure 3:

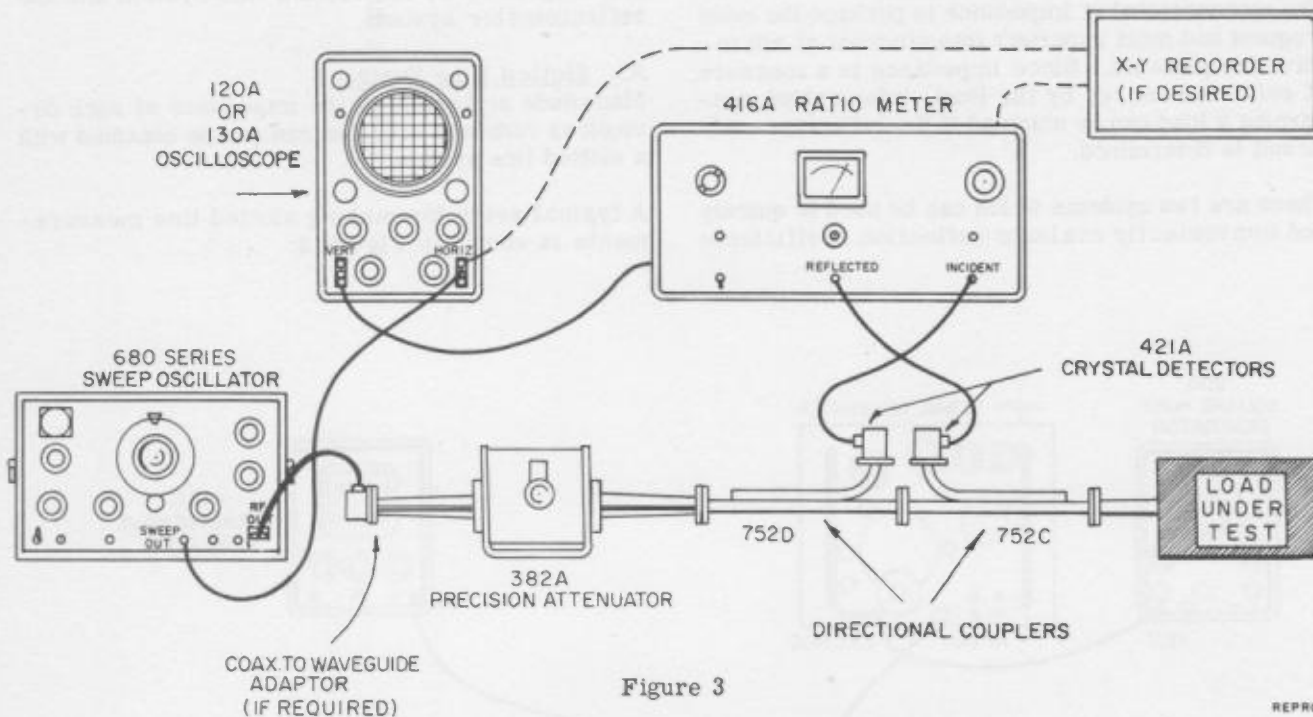

Figure 3

REPRO. B

1. The Sweep Oscillator supplies 1000 cps square wave rf power through directional couplers mounted back to back.
2. The 752D Coupler samples forward power and the 752C samples reverse or reflected power.
3. The auxiliary arms of both couplers are terminated in waveguide detector mounts such as the 421A which demodulate system power and provide 1000 cps signals to the ratiometer. The

oscilloscope presents frequency on its horizontal axis versus reflection coefficient on the vertical axis.

C. Impedance Measurements below 500 mc

Below 500 megacycles slotted sections become too long for practical use. However, impedance can be measured below 500 mc with the 803 VHF Bridge. A block diagram for this measurement is shown in Figure 4:

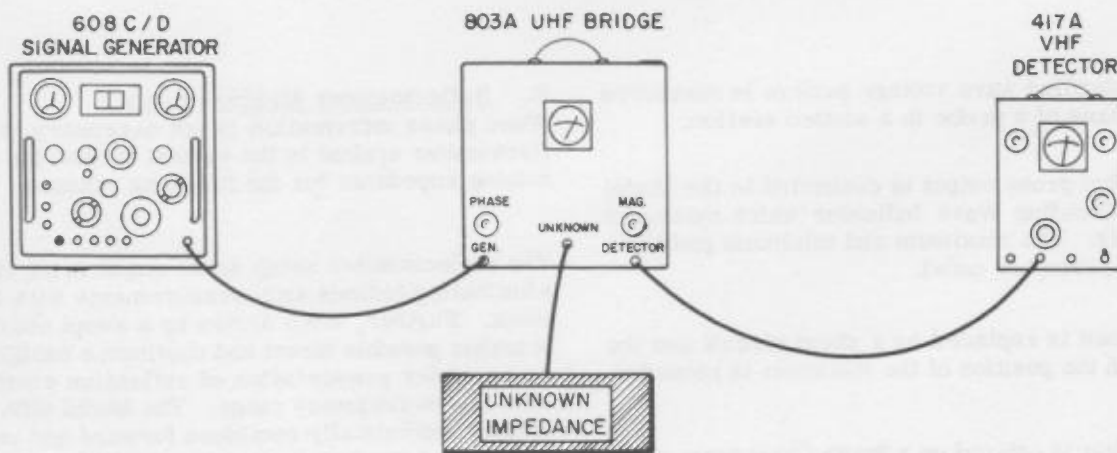

Figure 4

REPRO. B

1. The magnitude and phase dials of the Model 803A VHF Bridge are adjusted until a null is detected in the head phones which are plugged into the 417A VHF Detector.
2. The magnitude and phase of the impedance are read directly from the Model 803.

III. ATTENUATION MEASUREMENTS

There are two methods which can be used for making attenuation measurements quickly and accurately.

For the first method, a power level is first set on the 415B Standing Wave Indicator as shown in Figure 5. Care should be taken so that the power applied to the detector mount does not exceed 1 mv so the barretter will operate in the square law region. The unknown attenuation is next inserted in the system. The decrease in power level on the 415B is the attenuation on the unknown attenuator. By this method, and the use of an appropriate barretter, attenuations up to 40 db can be measured.

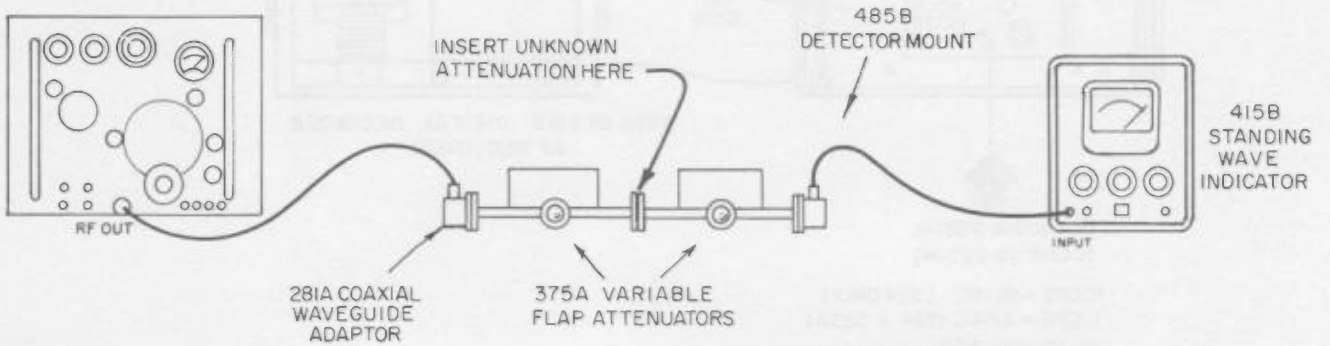

Figure 5

The second method is as follows:

The two 382's in Figure 6 are set at 0 db and a power level is set on the 415B. The unknown at-

tenuator is then removed from the system. The amount of attenuation which has to be added with the 382's to reach the same power level on the 415B is the attenuation of the unknown.

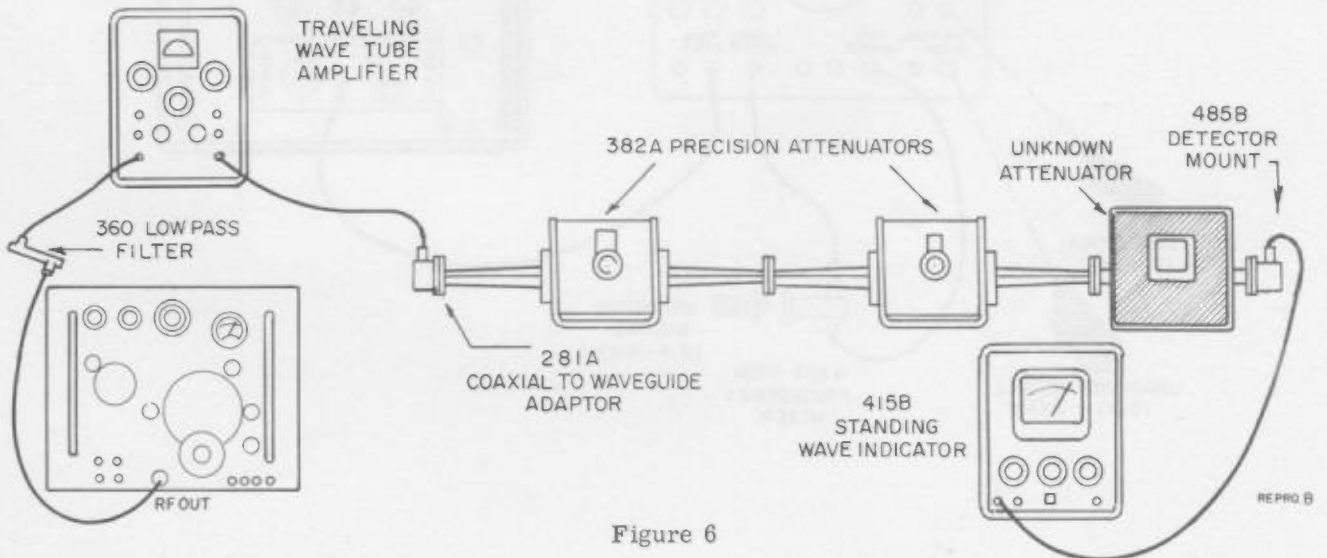
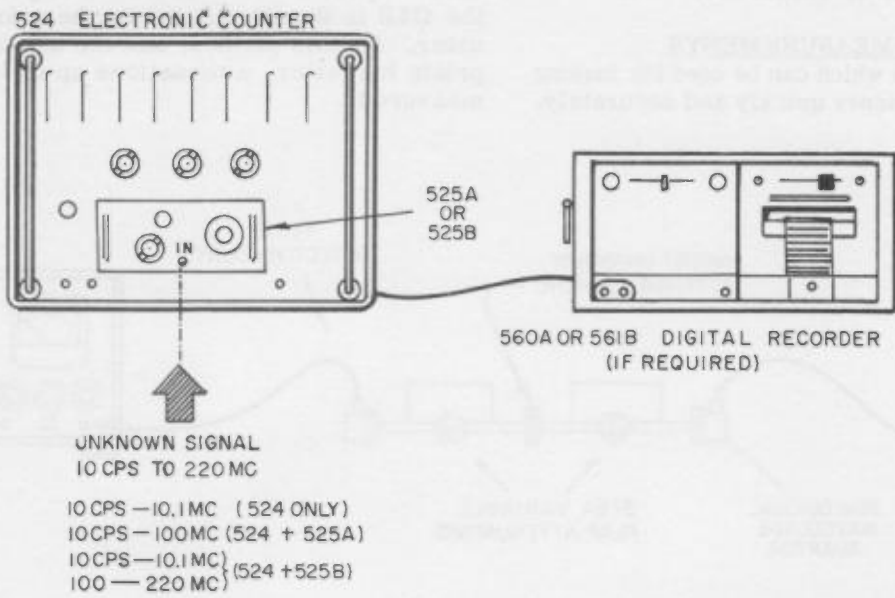

Figure 6

Frequency Measurements. 10 cps to 220 mc.



NEERO

Frequency Measurements. 10 mc to 18 kmc.

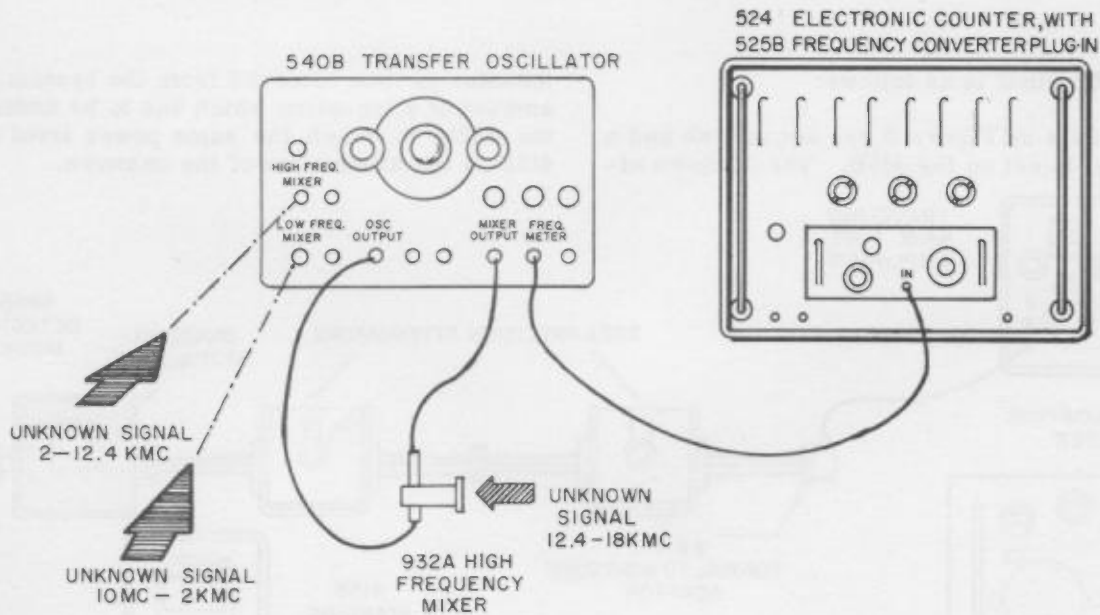

Figure 7

By this method, attenuations up to 100 db can be measured because you operate at the same power level, thus eliminating the problem of square law bolometer operation.

IV. FREQUENCY MEASUREMENTS

Frequencies from dc to 40 kmc can be measured and recorded with ϕ p frequency counters and associated equipment.

A block diagram of the ϕ p system for measuring frequencies up to 40 kmc is shown in Figure 7.

This system is extremely versatile because its major components can be used for other important applications. For example, the Model 524D Frequency Counter and the Model 560A Digital Recorder will

measure and record frequencies up to 220 mc, period, time intervals from one microsecond to 100 days, and with appropriate transducers, speed, pressure, temperature and flow.

Also, the Model 491A Traveling Wave Amplifier has a wide range of applications. For example, it can be used for broad band and narrow band amplification, power amplification and constant output amplification. It provides an exceptionally simple and flexible method of electronically checking radar, navigational and other instrumentation systems, because frequency shifts produced by sawtooth modulation make it uniquely suited for doppler simulation. Complicated methods for doppler simulation involving critically tuned crystals and mechanical cumbersome methods are thus eliminated.

EQUIPMENT FOR MICROWAVE MEASUREMENTS

POWER MEASUREMENTS

To 1 kw - 10 mc to 40,000 mc -- Coaxial and Waveguide Systems

Waveguide - Coax Adapters
S281A, G281A, J281A, H281A, X281A

Precision Attenuators
S380A, G382A, J382A, H382A, X382A, P382A, K382A, R382A

Directional Couplers (3 db)
S752A, G752A, J752A, H752A, X752A, P752A, K752A, R752A

Directional Couplers (10 db)
S752C, G752C, J752C, H752C, X752C, P752C, K752C, R752C

Directional Couplers (20 db)
S752D, G752D, J752D, H752D, X752D, P752D, K752D, R752D

Tunable Bolometer Mount
475B

Universal Bolometer Mount
476A

Coaxial Thermistor Mount
477B

Waveguide Detector Mounts
S485A, G485B, J485B, H485B, X485B

Waveguide Thermistor Mount
G487B, J487B, H487B, X487B, P487B, K487B, R487B

Microwave Power Meter
430C

Calorimetric Power Meter
434A

IMPEDANCE MEASUREMENTS

A. SLOTTED LINE MEASUREMENTS

Signal Generators
606A, 608C/D, 612A, 614A, 616A, 618B, 620A, 626A, 628A

Square Wave Generator
211A

Waveguide Frequency Meters
J530A, J530B, H530A, X530A, P530A, X532A, P532A, K532A, R532A

Flap Attenuators
S375A, G375A, J375A, H375A, X375A, P375A, K375A, R375A

Universal Probe Carriage (809B) and Slotted Sections
S810A, G810B, J810B, H810B, X810B, P810B, also 806B

Probe Carriage (18 to 40 Kmc)
814B

Slotted Sections (18 to 40 Kmc)
K815B, R815B

Coaxial Slotted Lines
805A/B

Broadband Probes
442B

Untuned Probes
444A, 446B

Standing Wave Indicators
415B

B. REFLECTOMETER MEASUREMENTS

Ratio Meter
416A

Oscilloscope
130B

Swept Frequency Oscillators
683A, 684A, 685A, H01686A, 686A, 687A

C. MEASUREMENTS BELOW 500 MC

VHF Bridge
803A

VHF Detector
417A

ATTENUATION MEASUREMENTS

No additional equipment necessary.

FREQUENCY MEASUREMENTS

Frequency Counter with Plug-In Units
524D, 525A, 525B

Digital Recorder
560A or 561B

Transfer Oscillator
540B

High Frequency Mixer
P932A

Traveling Wave Amplifiers
491A, 492A, 494A

2/28/61