

AUTOMATING THE HP 8410B MICROWAVE NETWORK ANALYZER



CONTENTS

| | |
|---|-----------|
| INTRODUCTION TO THE AUTOMATED NETWORK ANALYZER | 1 |
| ACCURACY ENHANCEMENT FUNDAMENTALS | 5 |
| TYPICAL MEASUREMENT RESULTS | 12 |
| CONFIGURING THE SYSTEM | 15 |
| SYSTEM FUNCTIONAL CHECK | 23 |

This application note describes the configuration and use of an automatic vector (magnitude and phase) RF and microwave network analyzer that is based upon the HP 8410B Network Analyzer, using the Hewlett-Packard Interface Bus (HP-IB), and HP 9845T Desktop Computer. This system is an improved version of the system described in HP Application Note 221 in these major respects:

- A Source Phase-lock Subsystem is incorporated to provide synthesizer-class frequency accuracy and repeatability. By phase-locking the receiver to the source, small magnitude and phase non-repeatabilities typical of non phase-locked systems are completely eliminated and precision measurement capability is extended to high Q and electrically long devices which require a very stable stimulus signal.
- A Test Set Selector, which allows measurements in either the 0.11 to 2 GHz or 2 to 18 GHz band without the need to manually change system configuration, is included. By electrically switching appropriate source and test set outputs to the network analyzer, this unit greatly reduces test time and simplifies measurements on devices which operate over both frequency ranges.
- Along with the Eight-term Error Model which provides full vector error correction for reflection measurements of one-port devices and fast transmission vector frequency-response-only error correction of two-port devices, this system offers a comprehensive Twelve-term Error Model to provide full vector error correction for transmission and reflection measurements of two-port devices.
- Group Delay is automatically computed from transmission phase data. Combining precision frequency accuracy with fully error corrected transmission phase information produces meaningful and flexible group delay measurements.

Although the HP 9845T controller offers several significant advantages for use with this system, fully documented programs are available from Hewlett-Packard for both the HP 9825A, as the HP 11863C (HPL), and for the HP 9845T, as the HP 11863D (HP Enhanced BASIC language).



HP-IB: Not just IEEE-488, but the hardware, documentation and support that delivers the shortest path to a measurement system.

INTRODUCTION TO THE AUTOMATED MICROWAVE NETWORK ANALYZER

This automated network analyzer configuration provides program control of the source output frequency, test set switching, receiver tuning, IF gain, and conversion of data to produce fully error-corrected transmission and reflection measurements from 0.11 to 18 GHz with a minimum of operator interaction. This synergism of a network analyzer and a fast computing controller allows rapid characterization of system errors using known calibration standards and subsequent error correction during measurement of unknown devices. In addition to the expected advantages of reduced test time and increased accuracy in large quantity production situations, its versatility, repeatability, and convenience also make this system a cost-effective tool in small volume production and specialized laboratory applications.

Since introduction of the HP 8410 Network Analyzer, engineers have found it to be extremely useful for characterizing virtually all types of microwave networks from devices to complete systems. With the advent of the Hewlett-Packard Interface Bus it became possible to produce a relatively inexpensive system for automated network measurements. At the present time, Hewlett-Packard offers a complete system ready for hook-up and immediate use, the HP 8409B Automatic Network Analyzer. A major contribution of the 8409 concept is that a basic system can be assembled using mostly standard instruments—many of which may already be available in your facility. This application note provides you with the equipment list, cabling diagram, checkout procedures, and operating information required to build and evaluate the system.

BASIC SYSTEM CONFIGURATION

Figure 1 shows the basic system configuration. The system consists of source, test set, and receiver instru-

mentation, HP-IB accessories required to automate these instruments, a desktop computer with HP-IB interface, and a complete program with all instrument control, computation, and operator interface modules necessary for accuracy enhanced measurements. The desktop computer controls the source, the relay actuator, and the analog-to-digital converter via the HP-IB. The relay actuator controls the test set S-parameter selection and the polar display IF attenuation.

For each measurement, the HP 8620C is programmed to a CW frequency, the polar display IF attenuation is autoranged to position the trace on the display, then the magnitude and phase are digitized and transferred to the desktop computer. Magnitude data is obtained using the HP 8412A rectilinear display down to about 40 dB of loss, and via the HP 8414A polar display from about 40 dB of loss down to the receiver noise floor. Phase data is always computed from the X and Y outputs of the polar display. This combination provides best magnitude accuracy, dynamic range, and freedom from phase ambiguities caused by transitions near the ± 180 degree point.

During the measurement calibration sequence, vector (magnitude and phase) error terms are measured and stored. A precision fixed or sliding load, a short circuit, a shielded open circuit, and a through connection are connected at the measurement plane to quantify directivity, source match, load match, isolation, and tracking errors at each frequency point. These systematic errors are then removed during the measurement sequence as the analyzer tunes back to each calibration frequency, measures the device response, and performs the error correction computation. The result is accurate, high resolution magnitude and phase data which is output in tabular form to a printer or in graphical form to a hard or soft copy plotter.

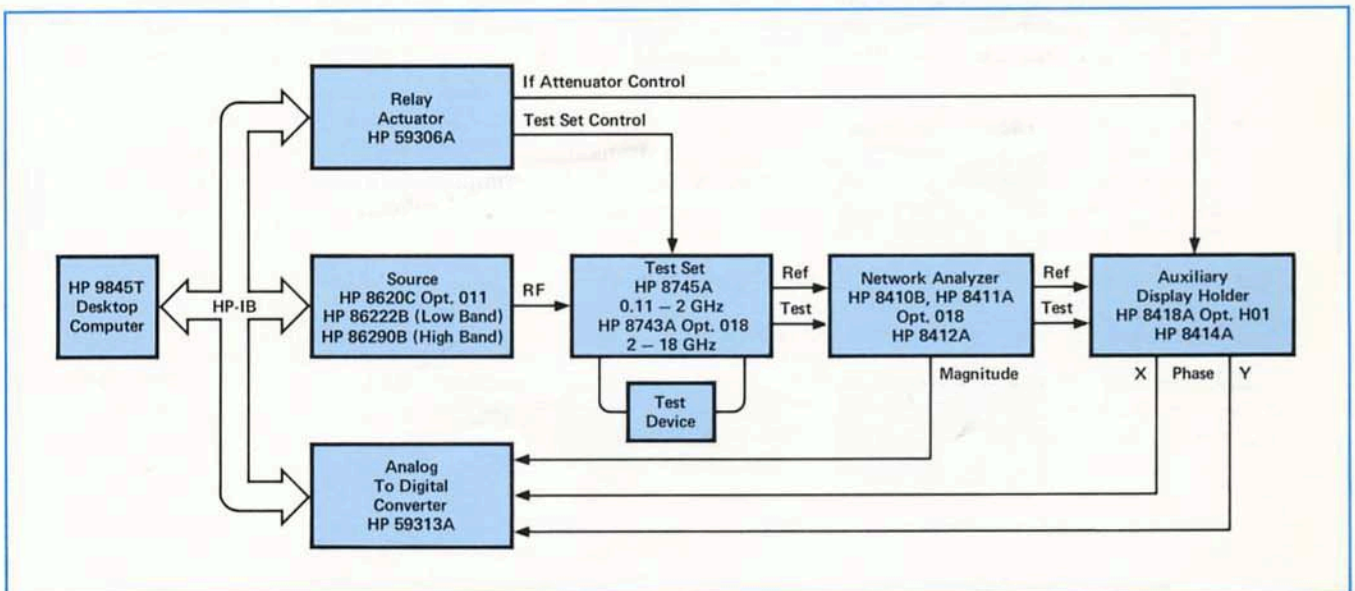

Figure 1. Basic Single Band Automated Network Analyzer Block Diagram.

SOURCE PHASE-LOCK SUBSYSTEM

Incorporating the Source Phase-lock Subsystem, consisting basically of the HP 3335A Synthesizer and the HP 8709A Option H17 Synchronizer shown in Figure 2, provides synthesizer class frequency accuracy and repeatability. This method improves typical worst case open loop 8620C/86290B programmed frequency accuracy from ± 2.5 MHz to about ± 1 part in 10^6 plus 5 kHz, and frequency repeatability from about ± 300 kHz to within 100 Hz. This improvement is especially valuable when measuring devices whose magnitude or phase response varies rapidly with frequency. Such devices include crystal filters, SAW devices, and long transmission lines. In these measurements, a small frequency error can result in a significant error in the measured parameter.

Also, the Source Phase-lock Subsystem eliminates

measurement errors due to a characteristic called "harmonic skip." The 8410B is a harmonic mixing receiver which selects a harmonic of its internal VCO for the local oscillator frequency used to down convert the test frequency to the first IF. Harmonic skip errors can occur when the receiver selects a different harmonic (and VCO frequency) for the same test frequency between calibration and measurement. The local oscillator power varies from one harmonic to another, thus, the mixer transfer characteristic varies, resulting in random magnitude and phase variations of from 0.1 to 0.4 dB and up to 2 degrees. Using the Source Phase-lock Subsystem substitutes the synthesizer as the internal VCO providing a local oscillator frequency which is precisely known and always repeated for any specific test frequency. This completely eliminates these random small magnitude and phase variations.

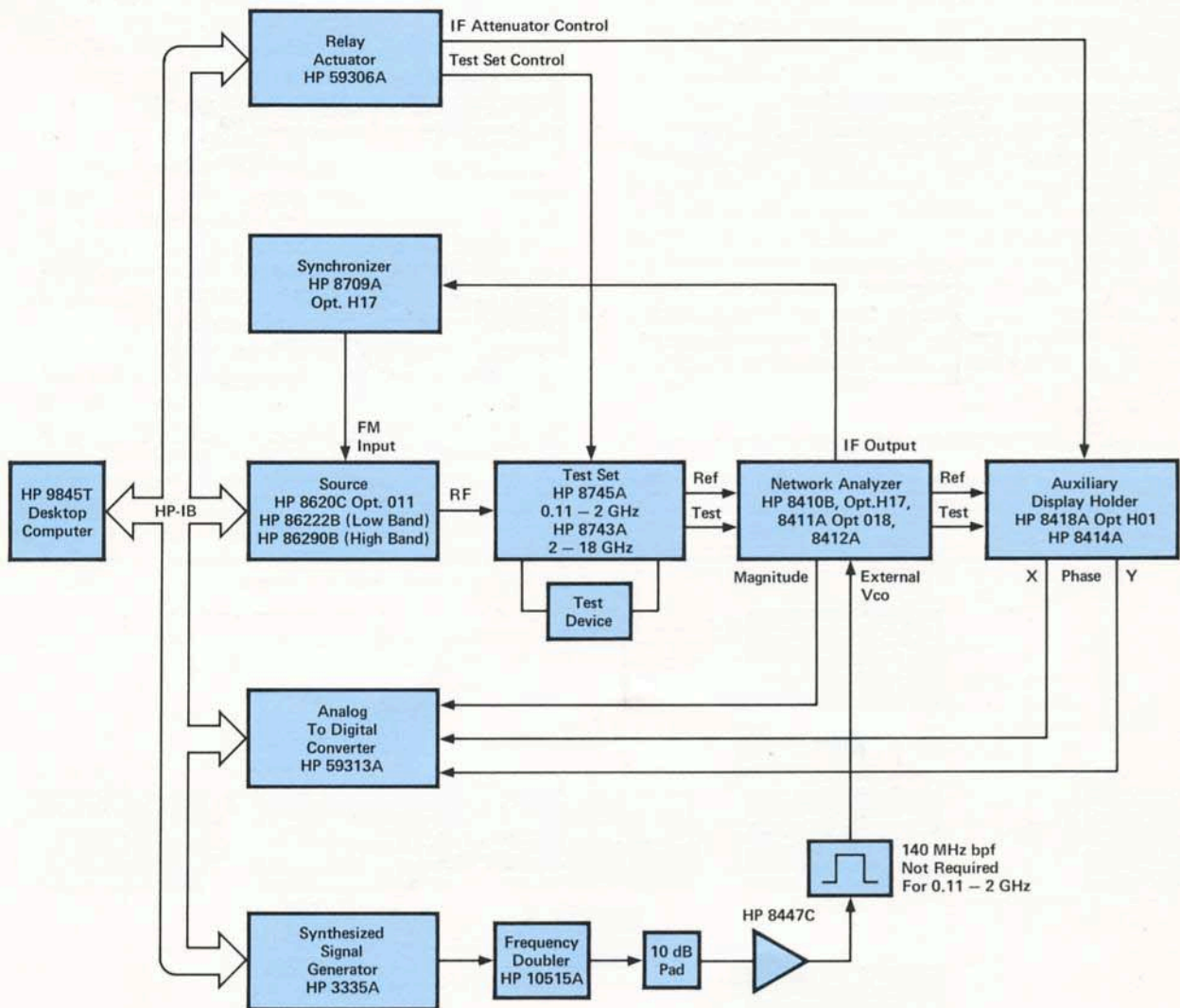

Figure 2. Automated Network Analyzer with Source Phase-lock Subsystem.

Figure 3 is a more detailed diagram of the Source Phase-lock Subsystem. The 8410B Option H17 is equipped with a front panel NORMAL/ ϕ LOCK switch. In the NORMAL position, the 8410B retains all standard capabilities. In the ϕ LOCK position, the internal 8410B phase lock-loop is bypassed, the output from the synthesizer is injected as the first local oscillator, and the 8410B IF is applied to the 8709A Option H17 Synchronizer.

At each frequency point, the 8620C is programmed to the test frequency in the same fashion as for the system shown in Figure 1. Next, the synthesizer is programmed to a specific submultiple of the local oscillator value required for test frequency down-conversion to the receiver 20.278 MHz IF. The IF is sampled by the synchronizer and compared with its internal 20.278 MHz crystal

oscillator. Because the 86290B programmed frequency resolution is typically 600 kHz and its frequency accuracy typically ± 2.5 MHz, an error signal is developed. This error output is applied to the source plug-in's FM input to fine tune the source to the exact required test frequency.

Other components used in the Source Phase-lock Subsystem are: the frequency doubler used to provide the required 65 to 150 MHz external VCO frequency; the 10 dB attenuator to provide a dc return path for the doubler; the HP 8447C amplifier to bring the signal up to the required level; and the 140 MHz center frequency, 10 MHz wide bandpass filter (not used in the 0.11 to 2 GHz range) to improve phase lock performance in the 2 to 18 GHz frequency range.

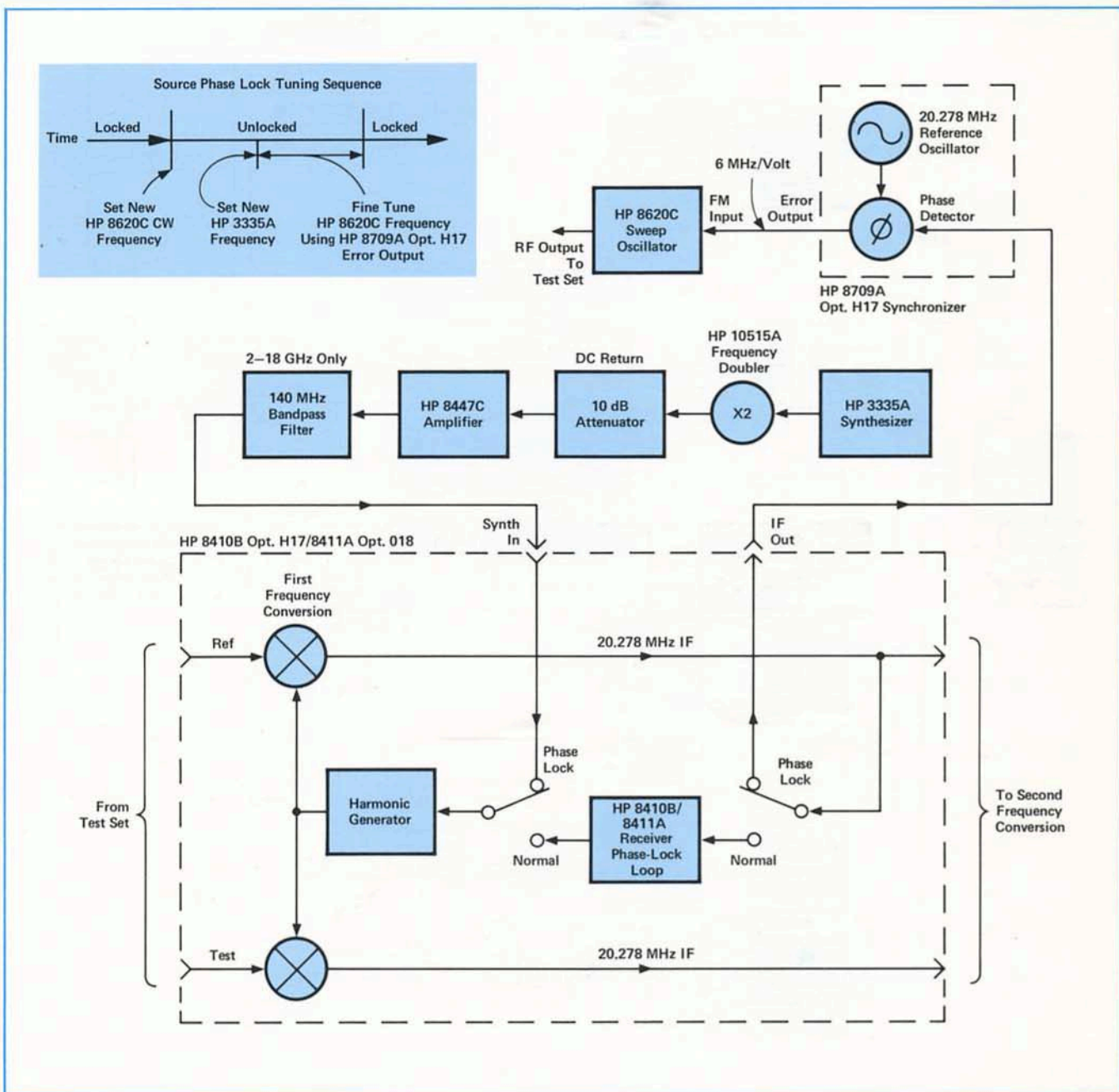

Figure 3. Source Phase-lock Subsystem Block Diagram.

MULTI-BAND CAPABILITY

Transmission and reflection characteristics are measured in two ranges, 0.11 to 2 GHz using the HP 8745A S-parameter test set and the HP 86222B Sweeper Plug-In, and 2 to 18 GHz using the HP 8743A Option 018 Transmission/Reflection Test Set and the HP 86290B Sweeper Plug-In. Incorporating the HP 8327A Test Set Selector, shown in Figure 4, allows both the high and low band sweeper/test set combinations to use a single HP 8411A Option 018 Harmonic Frequency Converter.

This eliminates the need to manually switch sweeper plug-ins, RF signal paths, source control interface connections, and the harmonic frequency converter between two test sets when changing frequency ranges. Although calibration and measurement proceeds in separate sequences for each range, the time required for switching between measurements in both ranges is further reduced because there is no need to allow the 1/2 hour minimum warmup time required when the 8411A power is removed during manual reconfiguration.

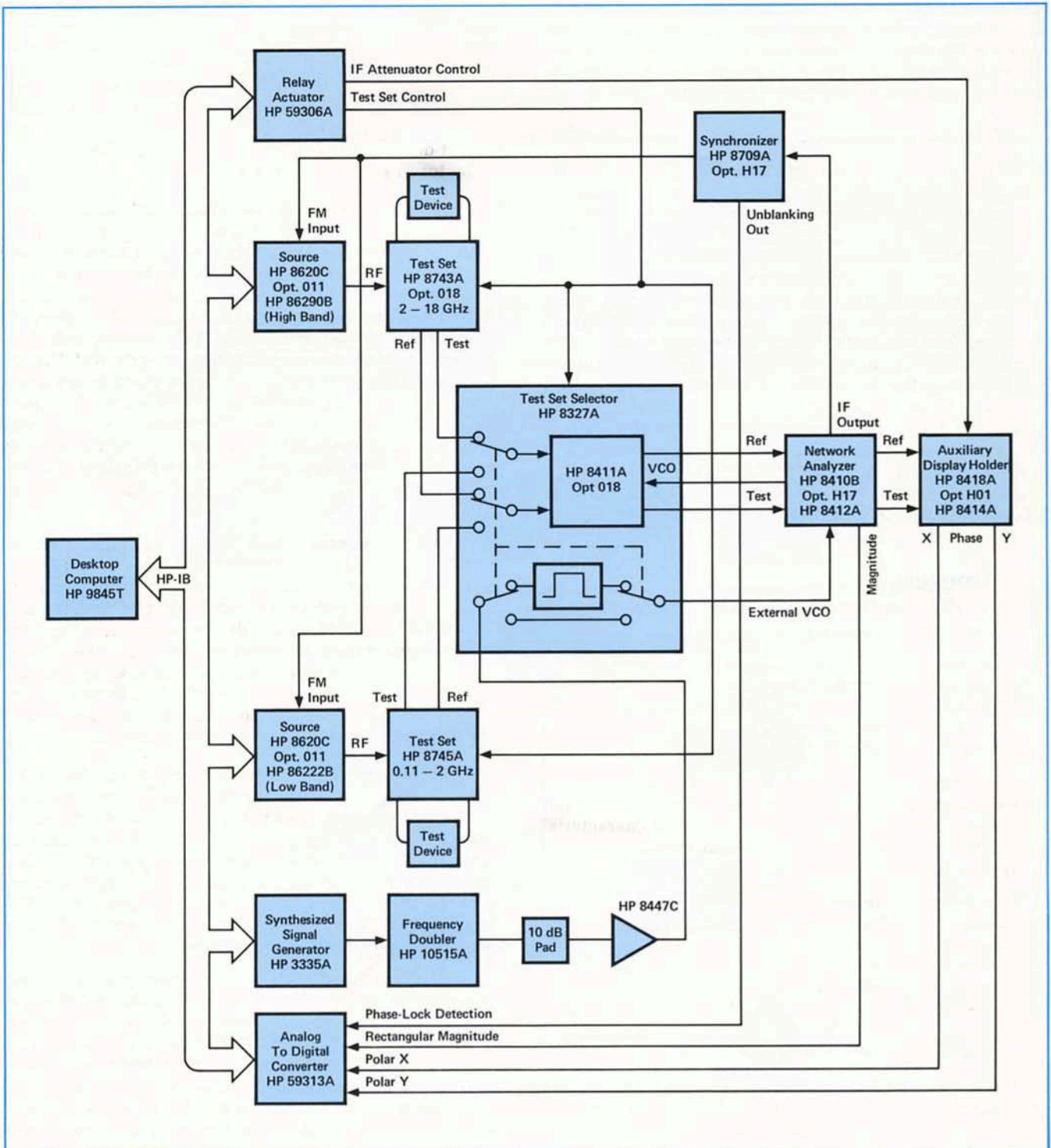

Figure 4. Automated Network Analyzer System with Multi-Band Switching and Source Phase-lock.

ACCURACY ENHANCEMENT FUNDAMENTALS

Vector accuracy enhancement techniques provide the means of reducing network analysis measurement ambiguities. For example, crosstalk due to the channel isolation characteristics of the receiver can contribute an error equal to the actual transmission characteristic of a high loss test device. Similarly, for reflection measurements the primary limitation of dynamic range is effective directivity of the test setup. When the magnitude of the reflected signal equals system effective directivity, the measurement system cannot distinguish the true value of the signal reflected at the measurement plane from the signal arriving at the receiver input due to leakage of the incident signal through the signal separation device. For all measurements, any impedance mismatches within the test setup can cause severe errors.

The objective is a perfect measurement system having infinite dynamic range, isolation, and directivity characteristics, no impedance mismatches in any part of the test setup, with flat frequency response. In practice, this "perfect" network analyzer is achieved by measuring the magnitude and phase response of known standard devices, using this data in conjunction with a model of the measurement system to determine error contributions, then measuring a test device and using vector mathematics to compute the actual test device response by removing the error terms. The dynamic range and accuracy of the measurement is then limited by system noise and the accuracy to which the characteristics of the calibration standards are known. This is the basic concept of vector accuracy enhancement. The following paragraphs describe the error model, the calibration standards, and the vector mathematics.

SOURCES OF MEASUREMENT ERRORS

Network analysis measurement errors can be separated into two categories:

Random Errors are non-repeatable measurement variations due to noise, temperature drift, and other physical changes in the test setup between calibration and measurement. These are any errors that the system itself cannot measure.

Systematic Errors are the repeatable errors which the system can measure. They include mismatch and leakage terms in the test setup, isolation characteristics between the reference and test signal paths, and system frequency response.

Thus, any measurement result is the vector sum of the actual test device response plus all error terms. The precise effect of each error term depends upon its magnitude and phase relationship to the actual test device response. The category of random errors, such as connector and switch repeatabilities, cannot be precisely quantified so they must be treated as producing a cumulative ambiguity in the measured data.

Fortunately, in most microwave measurements the systematic category of repeatable, measurable error terms is the most significant source of measurement uncertainty. Since each of these errors produces a predictable effect upon the measured data, their effects can

be removed to obtain a corrected value for test device response. For the purpose of vector accuracy enhancement, these uncertainties are quantified as directivity, source match, load match, isolation, and tracking (frequency response).

Effective Directivity—The vector sum of all leakage signals appearing at the receiver test input due to the inability of the signal separation device to absolutely separate incident and reflected waves, as well as residual reflection effects of test cables and adapters between the signal separation device and the measurement plane (the point at which the test device is connected). The uncertainty contributed by Effective Directivity is independent of characteristics of the test device and usually produces the major ambiguity factor in reflection measurements.

Here is an example of how directivity can affect your reflection measurement. Let's assume we desire to measure a device which has SMA connectors and an actual 24 dB return loss (1.13 SWR). Using SMA adapters in the test setup will typically degrade the 8743A test set directivity from over 30 dB to about 26 dB due to adapter reflections. This corresponds to a return loss measurement uncertainty of 20 dB! The uncorrected measured return loss value could be anywhere between 19 dB and 39 dB (1.02 to 1.26 SWR), depending upon how the actual and error signals combine vectorally at the test input. However, the vector accuracy enhancement technique described in this note will typically reduce this return loss uncertainty to ± 1 dB (1.13 ± 0.015 SWR).

Effective Source Match—The vector sum of signals appearing at the receiver test input due to inability of the source to maintain absolute constant power at the test device input as well as cable and adapter mismatches and losses outside the source leveling loop. The uncertainty contributed by Effective Source Match is dependent upon the relationship between the actual input impedance of the test device and the equivalent match of the source, and is a factor in both transmission and reflection measurements.

Source match error is particularly a problem when measuring very high or very low impedances (large mismatch at the measurement plane). For example, the source match looking back into the 8743A unknown port is about 1.3 SWR. When measuring a 0.92 reflection coefficient (e.g. 2 ohm diode) this leads to a potential ± 0.11 reflection coefficient (± 3 ohm) error. This error can typically be reduced by a factor of 10 by vector error correction techniques.

Effective Load Match—The vector sum of signals appearing at the receiver test input due to effects of impedance mismatches between the test device output port and the receiver test input. The uncertainty contributed by Effective Load Match is dependent upon the relationship between the actual output impedance of the test device and the effective match of the return port, and is a factor in all transmission measurements and in reflection measurements of two-port devices.

Load match effects are analyzed similarly to source match effects and will produce major transmission measurement errors for a test device whose output port is highly reflective. In the case of non-matched devices, for example semiconductor gain measurements, the error approaches 10 percent.

Isolation—The vector sum of signals appearing at the receiver detectors due to crosstalk between the reference and test signal paths, including signal leakage across test switches and within both the RF and IF sections of the receiver. The uncertainty contributed by Isolation is a factor in high loss transmission measurements.

The 8410B/8411A system maintains greater than 55 dB isolation between reference and test signal paths. Characterization and removal of isolation errors can extend the measurement system dynamic range up to 10 dB.

Tracking—The vector sum of all test setup variations in magnitude and phase frequency response, including signal separation device, test cables and adapters, and variations in frequency response between the reference and test signal paths. This error is unrelated to characteristics of the test device and is a factor in both transmission and reflection measurements.

As an example, the frequency response of a typical system may be ± 5 dB and ± 15 degrees from 2 to 18 GHz. These variations and the resultant measurement errors are removed completely using vector accuracy enhancement.

CORRECTING MEASUREMENT ERRORS

The accuracy enhancement program offers a choice between an Eight- or a Twelve-term error model. The Eight-term error model provides directivity, source match, and frequency response vector error correction for reflection measurements and simplified frequency-response-only vector error correction for transmission measurements. This model is best applied to high accuracy reflection measurements of one-port devices and to fast transmission measurements on two-port devices where normalization of magnitude and phase frequency response errors provides sufficient measurement accuracy. The Twelve-term error model provides full directivity, isolation, source match, load match, and frequency response vector error correction for transmission and reflection measurements of two-port devices. This model provides best magnitude and phase measurement accuracy but requires measurement of all four S-parameters of the two-port device.

The following discussion describes these error terms in greater detail and more importantly, how they can be characterized and used to reduce measurement uncertainty.

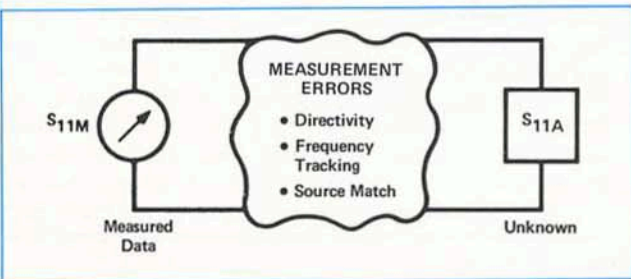

Let's consider measurement of reflection coefficients (magnitude and phase) of some unknown one-port device. No matter how careful we are, the measured data will differ from the actual. Effective Directivity, Effective Source Match, and Tracking are the major sources of error.

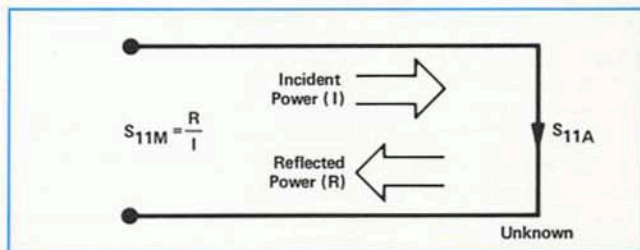

Reflection coefficient is measured by first separating the incident voltage wave (I) from the reflected voltage wave (R) then taking the ratio of the two values. Ideally, (R) consists only of the wave reflected by the test device (S_{11A}).

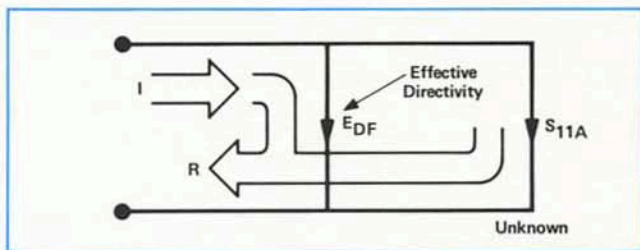

Unfortunately, all of the incident wave doesn't always reach the unknown. Some of (I) may appear at the measurement system input due to leakage through the signal separation device (coupler/bridge). Also, some of (I) may be reflected by imperfect adapters between signal separation and the measurement plane. The vector sum of the leakage and miscellaneous reflections is Effective Directivity, E_{DF} . Understandably, our measurement is distorted when the Effective Directivity signal combines vectorally with the actual reflected signal from the unknown, S_{11A} .

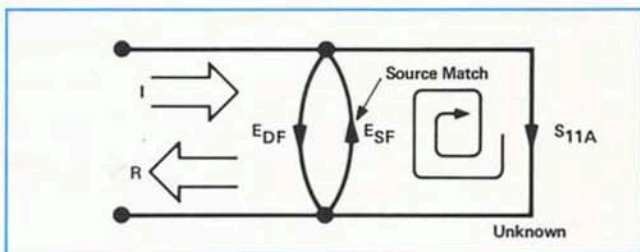

Since the measurement system test port is never exactly the characteristic impedance (normally 50 ohms), some of the reflected signal bounces off the test port (or other impedance transitions further down the line) and back to unknown, adding to the original incident signal (I). This effect causes the magnitude and phase of the incident wave to vary as a function of S_{11A} . Leveling the source to produce constant (I) reduces this error, but since the source cannot be leveled at the test device input, leveling cannot eliminate all power variations. This re-reflection effect and the resultant incident power variation is caused by the Effective Source Match error, E_{SF} .

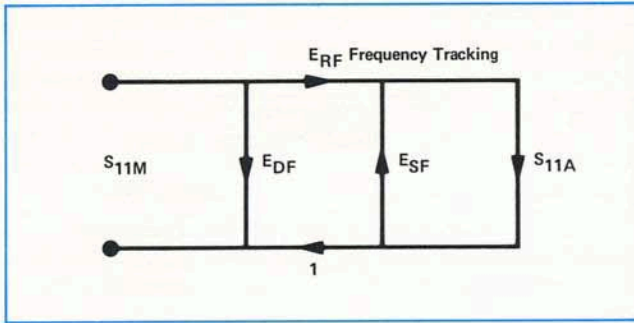

Tracking (frequency response) error is caused by variations in magnitude and phase flatness versus frequency between the test and reference signal paths. These are due mainly to imperfectly matched samplers and differences between incident and test couplers. The vector sum of these variations is the Reflection Tracking error, E_{RF} .

It can be shown that these three errors are mathematically related to the actual, S_{11A} , and measured, S_{11M} , data by the following equation.

$$S_{11M} = E_{DF} + \frac{S_{11A}(E_{RF})}{1 - E_{SF}S_{11A}}$$

If we knew the value of these three "E" errors and the measured test device response at each frequency, we could simply solve the above equation for S_{11A} to obtain the actual device response. Because each of these errors change with frequency, it is necessary that their values be known at each test frequency. They are found by measuring (calibrating) the system at the measurement plane using three independent standards whose S_{11A} is known at all frequencies.

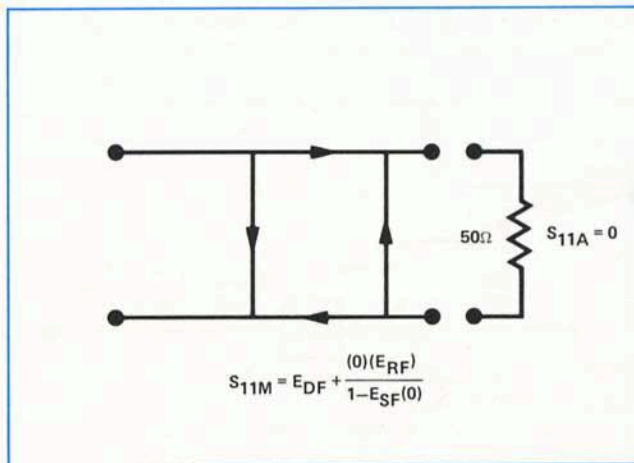

The first standard applied is a "perfect load" which makes $S_{11A}=0$ and essentially measures Effective Directivity. By "perfect load" we imply a reflectionless termination at the measurement plane. All incident energy is absorbed. With $S_{11A}=0$ the equation can be solved for E_{DF} , the Effective Directivity term. Of course, in practice the "perfect load" cannot be achieved.

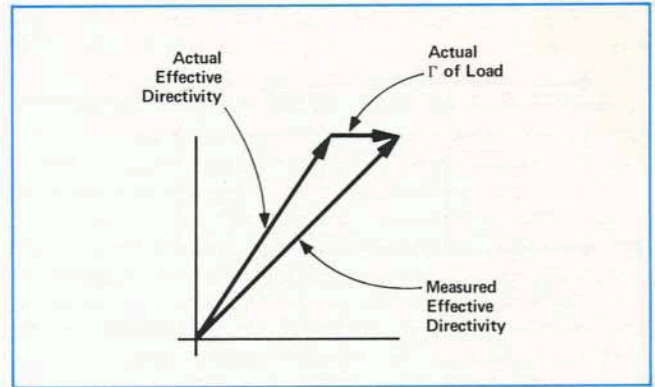

Since the measured value for Effective Directivity is the vector sum of the actual Effective Directivity plus the actual reflection coefficient of the "perfect load," any reflection from the termination represents an error. System Effective Directivity becomes the actual reflection coefficient of the "perfect load." In general, any termination having a return loss value greater than the uncorrected system directivity reduces reflection measurement uncertainty.

Due to the difficulty of producing a high quality fixed coaxial termination at microwave frequencies, a sliding load can be used at each test frequency to separate the reflection of a somewhat imperfect termination from the actual effective directivity.

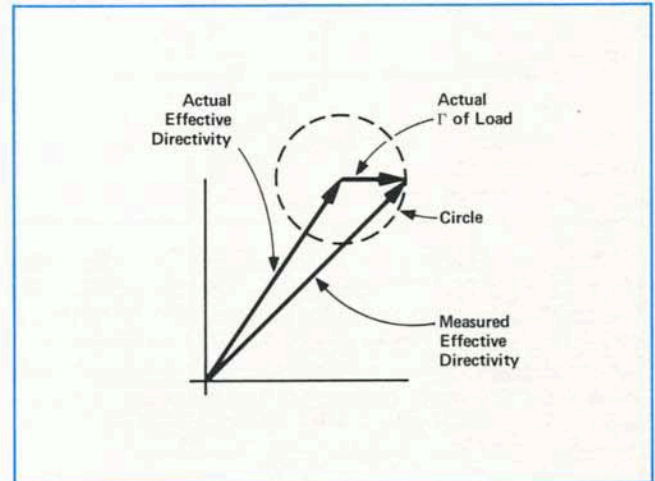

At any single frequency, moving the sliding termination with respect to the measurement plane produces a complete circle when the load is displaced one-half wavelength of the test frequency. Its reflection coefficient magnitude remains constant but the phase of the coefficient changes. The radius of that circle is the actual reflection coefficient of the sliding termination, and the center of the circle is determined by the actual Effective Directivity of the test setup and the geometry of the airline within the sliding load. Thus, the critical specifications for the sliding load assembly are the mechanical dimensions (impedance) of the connector and transmission line between the measurement plane and the termination, and that the termination maintains a constant reflection coefficient magnitude at all positions. The sliding load calibration sequence used in the accuracy enhancement program measures the sliding load at six positions, computes the center of the circle, then stores that value as system Effective Directivity.

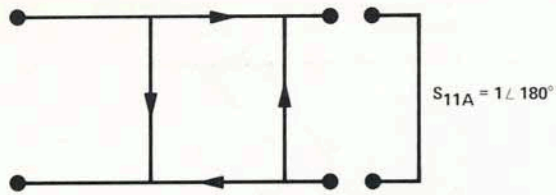

$$S_{11M} = E_{DF} + \frac{(-1)(E_{RF})}{1 - E_{SF}(-1)}$$

Next, a short circuit termination is used to establish the first condition of a two equation, two unknown solution to find E_{SF} and E_{RF} .

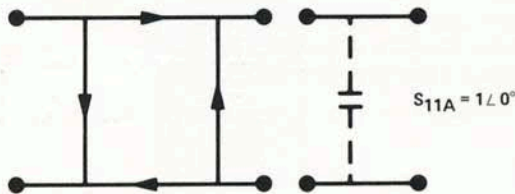

$$S_{11M} = E_{DF} + \frac{(1)(E_{RF})}{1 - E_{SF}(1)}$$

The open circuit gives us the second condition. Now the values for E_{SF} , Effective Source Match, and E_{RF} , Reflection Tracking are computed and stored. Note that in all cases a shielded open should be used to reduce magnitude and phase variations with frequency due to radiation from the open connector. The accuracy enhancement program can compensate for the residual fringing capacitance of the shielded open connector.

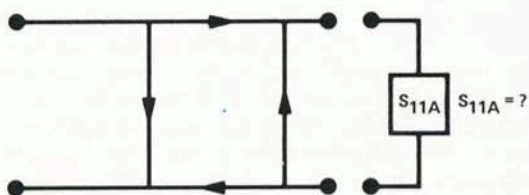

$$S_{11M} = E_{DF} + \frac{S_{11A}(E_{RF})}{1 - E_{SF}S_{11A}}$$

Now we measure the unknown to obtain a value for the measured response, S_{11M} , at each frequency.

$$S_{11A} = \frac{S_{11M} - E_{DF}}{E_{SF}(S_{11M} - E_{DF}) + E_{RF}}$$

This is the reflection part of the Eight-term error model equation solved for S_{11A} . Since we have the three errors and S_{11M} for each test frequency since we can compute S_{11A} .

For reflection measurements on two-port devices, the same technique can be applied, but the test device output port must be terminated in the system characteristic impedance. This termination should be at least as good (low reflection coefficient) as the load used to determine directivity. The additional reflection error caused by an improper termination at the test device output port is not incorporated into the Eight-term error model.

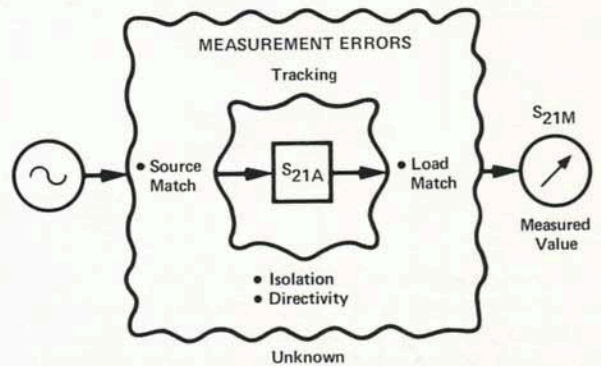

Now consider measurement of transmission coefficients (magnitude and phase) of an unknown two-port device. The major sources of error are Tracking, Effective Source Match, Effective Load Match, and Isolation. The Eight-term error model removes Transmission Tracking errors; the Twelve-term error model removes Transmission Tracking, Effective Source Match, Effective Load Match, Effective Directivity, and Isolation.

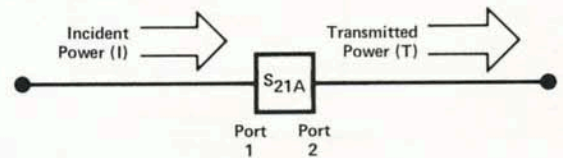

Transmission coefficient is measured by taking the ratio of the incident voltage wave (I) and the transmitted wave (T). Ideally, (I) consists only of power delivered by the source and (T) consists only of power emerging at the test device output.

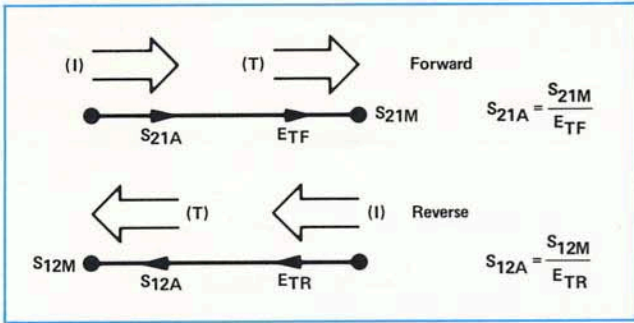

Both the Eight- and Twelve-term error models for transmission eliminate the forward and reverse Transmission Tracking terms. Transmission Tracking is measured with the test set in the transmission configuration with a thru connection (connect the points at which the test device will be connected to achieve a zero loss, zero length transmission line). If the test set can switch the incident signal to measure the reverse transmission coefficient, S_{12} , without the need to manually disconnect and reverse the test device (S-parameter Test Set), the reverse Transmission Tracking term, E_{TR} is also measured. Otherwise, the forward transmission tracking term, E_{TF} , is used for both forward and reverse measurements.

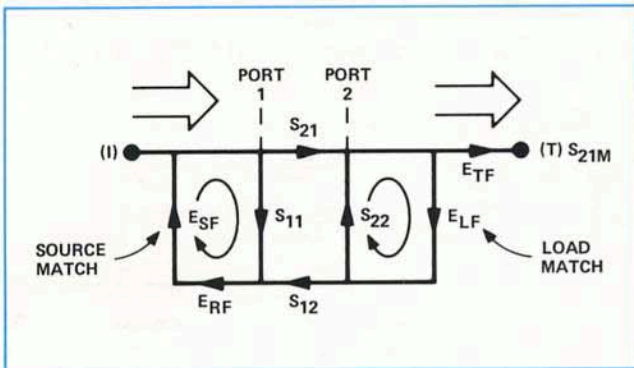

As in the reflection model, Effective Source Match can cause the incident power to vary as a function of test device S_{11A} . Also, since the test setup transmission return port is never exactly the characteristic impedance, some of the transmitted signal is reflected from the return port, and other mismatches between test device Port 2 and the detector, to return to Port 2. A portion of this wave may be re-reflected at Port 2, thus affecting S_{21M} , or part may be re-transmitted through the device in the reverse direction to appear at Port 1, thus affecting S_{11M} . This error term, which causes the magnitude and phase of the actual transmitted signal to vary as a function of S_{22A} , is called Effective Load Match, E_{LF} .

The measured value, S_{21M} , consists of wave components which vary as a function of the relationship between E_{SF} and S_{11A} as well as E_{LF} and S_{22A} , so the input and output reflection coefficients of the test device must be measured and stored for use in the S_{21A} error correction computation. Thus, the test setup is calibrated as described above for reflection to establish Directivity, E_{DF} , Effective Source Match, E_{SF} , and Reflection Tracking, E_{RF} , terms for the reflection measurements. After reflection calibration, Effective Load Match is determined by measuring the reflection coefficient of the thru connection.

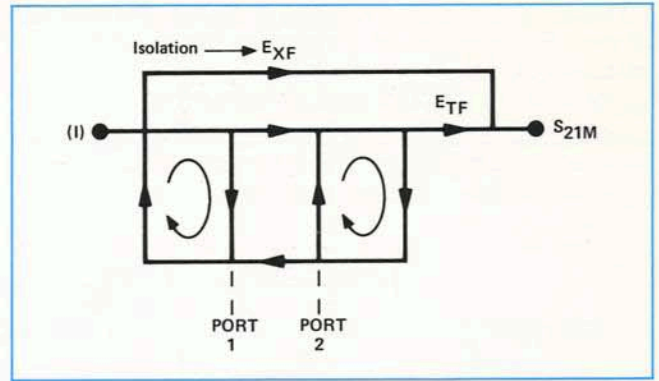

Isolation, E_{XF} , represents the part of the incident wave that appears at the receiver detectors without actually passing through the test device. Isolation is measured with the test set in the transmission configuration and a fixed termination installed at the points at which the test device will be connected. Transmission Tracking, E_{TF} , is then measured with the thru connection installed.

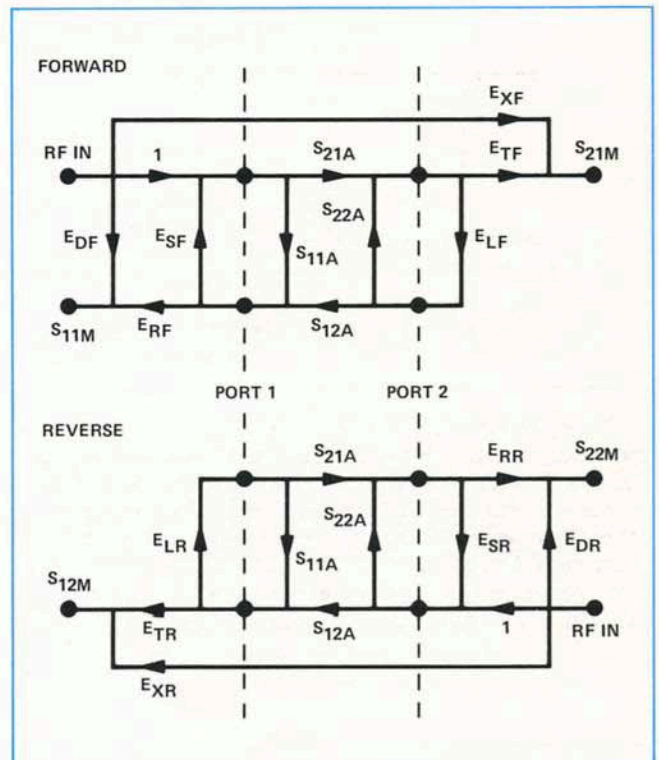

Since some microwave test sets can measure both the forward and reverse characteristics of the test device without the need to manually remove and physically reverse it, the comprehensive Twelve-term transmission and reflection error model above includes terms for Effective Directivity, E_{DF} (forward) and E_{DR} (reverse), Isolation, E_{XF} and E_{XR} , Effective Source Match, E_{SF} and E_{SR} , Effective Load Match, E_{LF} and E_{LR} , Transmission Tracking, E_{TF} and E_{TR} , and Reflection Tracking, E_{RF} and E_{RR} . Thus, there are two sets of error terms, forward and reverse, with each set consisting of six error terms. If the test set cannot switch between forward and reverse, then the reverse terms cannot be measured and the forward error terms are used in their place when the test device is manually reversed.

These are the Twelve Term error model equations for all four S-parameters of a two-port device. Note that mathematics for this comprehensive two-port error model uses all forward and reverse error terms and

measured values. Thus, to perform full error correction for any one parameter, all four S-parameters must be measured.

$$S_{11A} = \frac{\left[\left(\frac{S_{11M} - E_{DF}}{E_{RF}} \right) \left[1 + \left(\frac{S_{22M} - E_{DR}}{E_{RR}} \right) E_{SR} \right] \right] - \left[\left(\frac{S_{21M} - E_{XF}}{E_{TF}} \right) \left(\frac{S_{12M} - E_{XR}}{E_{TR}} \right) E_{LF} \right]}{\left[1 + \left(\frac{S_{11M} - E_{DF}}{E_{RF}} \right) E_{SF} \right] \left[1 + \left(\frac{S_{22M} - E_{DR}}{E_{RR}} \right) E_{SR} \right] - \left[\left(\frac{S_{21M} - E_{XF}}{E_{TF}} \right) \left(\frac{S_{12M} - E_{XR}}{E_{TR}} \right) E_{LF} E_{LR} \right]}$$

$$S_{21A} = \frac{\left[1 + \left(\frac{S_{22M} - E_{DR}}{E_{RR}} \right) (E_{SR} - E_{LF}) \right] \left(\frac{S_{21M} - E_{XF}}{E_{TF}} \right)}{\left[1 + \left(\frac{S_{11M} - E_{DF}}{E_{RF}} \right) E_{SF} \right] \left[1 + \left(\frac{S_{22M} - E_{DR}}{E_{RR}} \right) E_{SR} \right] - \left[\left(\frac{S_{21M} - E_{XF}}{E_{TF}} \right) \left(\frac{S_{12M} - E_{XR}}{E_{TR}} \right) E_{LF} E_{LR} \right]}$$

$$S_{12A} = \frac{\left[1 + \left(\frac{S_{11M} - E_{DF}}{E_{RF}} \right) (E_{SF} - E_{LR}) \right] \left(\frac{S_{12M} - E_{XR}}{E_{TR}} \right)}{\left[1 + \left(\frac{S_{11M} - E_{DF}}{E_{RF}} \right) E_{SF} \right] \left[1 + \left(\frac{S_{22M} - E_{DR}}{E_{RR}} \right) E_{SR} \right] - \left[\left(\frac{S_{21M} - E_{XF}}{E_{TF}} \right) \left(\frac{S_{12M} - E_{XR}}{E_{TR}} \right) E_{LF} E_{LR} \right]}$$

$$S_{22A} = \frac{\left[\left(\frac{S_{22M} - E_{DR}}{E_{RR}} \right) \left[1 + \left(\frac{S_{11M} - E_{DF}}{E_{RF}} \right) E_{SF} \right] \right] - \left[\left(\frac{S_{21M} - E_{XF}}{E_{TF}} \right) \left(\frac{S_{12M} - E_{XR}}{E_{TR}} \right) E_{LR} \right]}{\left[1 + \left(\frac{S_{11M} - E_{DF}}{E_{RF}} \right) E_{SF} \right] \left[1 + \left(\frac{S_{22M} - E_{DR}}{E_{RR}} \right) E_{SR} \right] - \left[\left(\frac{S_{21M} - E_{XF}}{E_{TF}} \right) \left(\frac{S_{12M} - E_{XR}}{E_{TR}} \right) E_{LF} E_{LR} \right]}$$

COMPUTING GROUP DELAY

Either error model can produce the transmission group delay measurement. Reduced phase measurement uncertainty due to error correction combined with increased frequency accuracy and repeatability of the source phase-lock subsystem provide very meaningful and flexible group delay measurements. Prior to this implementation it was quite difficult to make useful group delay measurements at microwave frequencies.

Group delay is the measurement of signal transit time through a test device. It is defined as the derivative of the phase characteristic with respect to frequency. Since the derivative is basically the instantaneous slope (or

rate of change of phase with frequency), a perfectly linear phase shift will result in a constant slope and, therefore, a constant group delay.

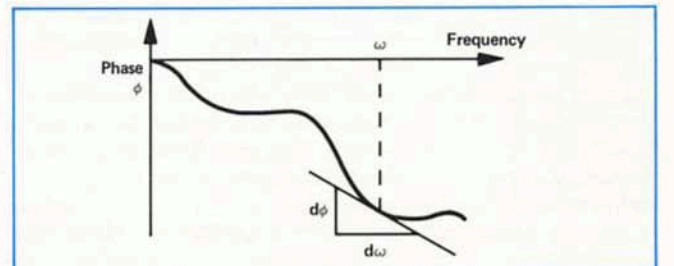

TYPICAL MEASUREMENT RESULTS

The following pages contain several samples of typical measurement data along with standard and special data output formats. Figure 5 compares measurement results obtained using a metrology standards system (HP 8542B) with results obtained using an HP 8409B system and an 8409A system (without source phase-

lock). Figures 6 and 7 present several examples of printed and plotted outputs made using the 9845T Desktop Computer and the 9872B Graphics Plotter. The accuracy enhancement program is fully documented in its manual allowing you to reformat data to suit your individual requirements.

| 10 cm Air Line Transmission Coefficient (S ₁₁) | | | | | | |
|---|-------------------|--------------------|--------------------|--------------------|--------------------|--------------------|
| Freq (MHz) | Magnitude (dB) | | | Phase (degrees) | | |
| | 8542B | 8409B ¹ | 8409A ² | 8542B | 8409B ¹ | 8409A ² |
| 2000 | 0.02 | 0.05 | 0.1 | 114.46 | 114.6 | 114 |
| 3000 | 0.04 | 0.00 | 0.1 | -8.16 | -8.1 | -9 |
| 4000 | 0.06 | 0.05 | 0.0 | -130.91 | -131.0 | -132 |
| 5000 | 0.04 | 0.05 | 0.1 | 106.77 | 106.6 | 107 |
| 6000 | 0.06 | 0.05 | -0.1 | -16.31 | -16.0 | -18 |
| 7000 | 0.06 | 0.05 | 0.1 | -138.72 | -138.2 | -142 |
| 8000 | 0.09 | 0.07 | 0.1 | 98.60 | 98.7 | 95 |
| 9000 | 0.06 | 0.05 | 0.0 | -24.17 | -24.5 | -25 |
| 10000 | 0.07 | 0.10 | 0.0 | -146.60 | -146.9 | -152 |
| 11000 | 0.07 | 0.09 | 0.0 | 90.52 | 89.9 | 90 |
| 12000 | 0.10 | 0.06 | 0.0 | -31.81 | -31.4 | -35 |
| 13000 | 0.14 | 0.04 | -0.3 | -154.31 | -156.2 | -156 |
| 14000 | 0.11 | 0.08 | -0.2 | 83.0 | 82.5 | 77 |
| 15000 | 0.10 | 0.06 | 0.1 | -39.6 | -40.6 | -46 |
| 16000 | 0.10 | 0.09 | 0.0 | -162.81 | -163.2 | -168 |
| 17000 | 0.17 | 0.10 | 0.0 | 74.96 | 73.8 | 68 |
| 18000 | 0.05 | 0.10 | 0.1 | -48.69 | -48.4 | -55 |

| Offset Short S/N 10000S Reflection Coefficient (S ₁₁) | | | | | | |
|--|-------------------|--------------------|--------------------|--------------------|--------------------|--------------------|
| Freq (MHz) | Magnitude (dB) | | | Phase (degrees) | | |
| | 8542B | 8409B ¹ | 8409A ² | 8542B | 8409B ¹ | 8409A ² |
| 2000 | 0.02 | 0.01 | 0.0 | -60.05 | -60.1 | -61 |
| 3000 | 0.04 | 0.01 | 0.0 | 179.56 | 179.1 | 179 |
| 4000 | 0.07 | 0.03 | -0.1 | 59.75 | 59.5 | 60 |
| 5000 | -0.04 | -0.04 | -0.2 | -60.08 | -60.3 | -62 |
| 6000 | 0.5 | 0.06 | 0.0 | 179.25 | 179.2 | 178 |
| 7000 | 0.09 | 0.08 | 0.1 | 60.35 | 59.8 | 59 |
| 8000 | 0.02 | -0.02 | 0.0 | -58.36 | -60.9 | -61 |
| 9000 | 0.06 | 0.05 | 0.0 | 178.87 | 178.9 | 177 |
| 10000 | 0.04 | -0.07 | 0.1 | 58.86 | 60.2 | 58 |
| 11000 | 0.11 | 0.07 | 0.1 | -61.10 | -60.5 | -61 |
| 12000 | 0.07 | 0.05 | 0.0 | 178.56 | 178.8 | 176 |
| 13000 | 0.09 | 0.10 | 0.3 | 58.53 | 58.6 | 57 |
| 14000 | 0.08 | 0.02 | 0.0 | -60.84 | -60.2 | -61 |
| 15000 | 0.09 | 0.04 | 0.0 | 177.98 | 178.3 | 177 |
| 16000 | 0.06 | 0.18 | 0.4 | 58.36 | 58.7 | 59 |
| 17000 | 0.12 | 0.06 | 0.1 | -61.65 | -60.4 | -62 |
| 18000 | 0.17 | 0.06 | 0.0 | 177.76 | 177.8 | 177 |

| Coaxial Attenuator S/N 50620 Transmission Coefficient (S ₁₁) | | | | | | |
|---|-------------------|--------------------|--------------------|--------------------|--------------------|--------------------|
| Freq (MHz) | Magnitude (dB) | | | Phase (degrees) | | |
| | 8542B | 8409B ¹ | 8409A ² | 8542B | 8409B ¹ | 8409A ² |
| 2000 | 50.96 | 51.23 | 51.1 | -156.53 | -154.5 | -154 |
| 3000 | 50.87 | 51.18 | 51.1 | 125.06 | 126.2 | 125 |
| 4000 | 50.95 | 51.14 | 51.0 | 47.02 | 47.9 | 47 |
| 5000 | 50.91 | 50.90 | 50.8 | -31.06 | -28.5 | -29 |
| 6000 | 50.86 | 50.79 | 51.1 | -110.07 | -108.7 | -107 |
| 7000 | 50.54 | 50.79 | 50.9 | 172.44 | 173.9 | 172 |
| 8000 | 50.49 | 50.84 | 50.8 | 93.42 | 94.6 | 94 |
| 9000 | 50.33 | 50.36 | 50.5 | 15.07 | 18.4 | 15 |
| 10000 | 50.31 | 50.04 | 50.9 | -64.96 | -60.2 | -65 |
| 11000 | 50.12 | 49.84 | 50.6 | -144.07 | -143.4 | -145 |
| 12000 | 49.95 | 50.29 | 50.3 | 136.97 | 136.3 | 135 |
| 13000 | 49.89 | 50.07 | 49.7 | 56.61 | 56.1 | 62 |
| 14000 | 49.86 | 50.16 | 49.6 | -23.78 | -26.2 | -25 |
| 15000 | 49.72 | 49.85 | 50.0 | -105.08 | -102.4 | -108 |
| 16000 | 49.92 | 49.71 | 49.5 | 170.96 | 172.7 | 165 |
| 17000 | 50.45 | 49.80 | 51.3 | 88.38 | 86.5 | 81 |
| 18000 | 51.24 | 51.43 | 51.5 | 0.10 | -2.9 | 5 |

| Termination S/N 10.185 Reflection Coefficient (S ₁₁) | | | | | | |
|---|-------------------|--------------------|--------------------|--------------------|--------------------|--------------------|
| Freq (MHz) | Magnitude (dB) | | | Phase (degrees) | | |
| | 8542B | 8409B ¹ | 8409A ² | 8542B | 8409B ¹ | 8409A ² |
| 2000 | 14.39 | 14.45 | 14.5 | -139.35 | -138.9 | -139 |
| 3000 | 14.47 | 14.57 | 14.5 | 151.10 | 151.2 | 151 |
| 4000 | 14.58 | 14.70 | 14.6 | 81.30 | 81.8 | 81 |
| 5000 | 14.71 | 14.82 | 14.8 | 11.24 | 10.4 | 10 |
| 6000 | 14.67 | 14.71 | 14.6 | -59.94 | -61.1 | -61 |
| 7000 | 14.46 | 14.43 | 14.3 | -130.62 | -131.4 | -130 |
| 8000 | 14.25 | 14.15 | 14.1 | 161.24 | 160.7 | 161 |
| 9000 | 14.10 | 14.12 | 14.3 | 93.12 | 94.6 | 94 |
| 10000 | 14.36 | 14.38 | 14.5 | 25.66 | 29.0 | 26 |
| 11000 | 14.84 | 14.73 | 15.0 | -42.71 | -40.2 | -42 |
| 12000 | 15.15 | 15.25 | 15.4 | -113.25 | -111.8 | -115 |
| 13000 | 15.28 | 15.49 | 15.6 | 176.42 | 177.4 | 177 |
| 14000 | 15.42 | 15.74 | 15.9 | 108.60 | 108.4 | 108 |
| 15000 | 15.98 | 16.16 | 16.2 | 40.61 | 40.1 | 40 |
| 16000 | 16.88 | 16.80 | 16.9 | -29.60 | -28.6 | -29 |
| 17000 | 17.45 | 17.57 | 17.6 | -102.80 | -99.4 | -102 |
| 18000 | 17.33 | 17.59 | 17.5 | -173.79 | -168.8 | -169 |

¹ (Phase-locked)

² (Non Phase-locked)

Figure 5. Comparison Data.

FILTER 11246B

| FREQUENCY MHz | RETURN LOSS-IN S11 | | RETURN LOSS-OUT S22 | | LOSS-FORWARD S21 | | LOSS-REVERSE S12 | |
|------------------|-----------------------|--------|------------------------|-------|---------------------|--------|---------------------|--------|
| | DB | ANG | DB | ANG | DB | ANG | DB | ANG |
| 5875.0000 | 3.80 | 106.9 | 3.34 | 127.7 | 4.35 | 34.0 | 4.31 | 33.6 |
| 5880.0000 | 5.55 | 89.3 | 4.87 | 119.5 | 2.98 | 20.1 | 3.02 | 19.7 |
| 5885.0000 | 8.19 | 68.3 | 7.12 | 113.6 | 2.01 | 4.9 | 2.08 | 4.8 |
| 5890.0000 | 12.13 | 41.5 | 10.10 | 113.0 | 1.36 | -10.3 | 1.43 | -10.0 |
| 5895.0000 | 17.38 | -2.2 | 13.28 | 124.7 | 1.06 | -24.9 | 1.09 | -24.4 |
| 5900.0000 | 18.65 | -75.8 | 14.49 | 148.4 | .96 | -38.1 | .92 | -37.7 |
| 5905.0000 | 15.13 | -120.6 | 13.26 | 165.5 | .96 | -50.1 | .91 | -50.0 |
| 5910.0000 | 12.59 | -144.2 | 11.69 | 171.5 | .99 | -61.0 | .99 | -61.0 |
| 5915.0000 | 11.07 | -161.2 | 10.51 | 171.8 | 1.07 | -71.1 | 1.06 | -71.2 |
| 5920.0000 | 10.17 | -175.5 | 9.78 | 169.5 | 1.12 | -80.3 | 1.12 | -80.4 |
| 5925.0000 | 9.69 | 171.3 | 9.35 | 166.0 | 1.16 | -88.9 | 1.18 | -88.9 |
| 5930.0000 | 9.47 | 159.5 | 9.15 | 162.5 | 1.21 | -97.0 | 1.22 | -97.0 |
| 5935.0000 | 9.51 | 148.2 | 9.20 | 158.7 | 1.22 | -104.6 | 1.21 | -104.6 |
| 5940.0000 | 9.69 | 137.5 | 9.35 | 155.0 | 1.19 | -112.0 | 1.20 | -112.0 |
| 5945.0000 | 10.04 | 126.3 | 9.66 | 151.6 | 1.14 | -119.4 | 1.17 | -119.2 |

Standard 9845B Printed Output

FILTER 11246B

| FREQUENCY MHz | REFL COEFF -IN S11 | | REFL COEFF -OUT S22 | |
|------------------|-----------------------|--------|------------------------|-------|
| | MAG | ANG | MAG | ANG |
| 5875.0000 | .65 | 106.9 | .68 | 127.7 |
| 5880.0000 | .53 | 89.3 | .57 | 119.5 |
| 5885.0000 | .39 | 68.3 | .44 | 113.6 |
| 5890.0000 | .25 | 41.5 | .31 | 113.0 |
| 5895.0000 | .14 | -2.2 | .22 | 124.7 |
| 5900.0000 | .12 | -75.8 | .19 | 148.4 |
| 5905.0000 | .18 | -120.6 | .22 | 165.5 |
| 5910.0000 | .23 | -144.2 | .26 | 171.5 |
| 5915.0000 | .28 | -161.2 | .30 | 171.8 |
| 5920.0000 | .31 | -175.5 | .32 | 169.5 |
| 5925.0000 | .33 | 171.3 | .34 | 166.0 |
| 5930.0000 | .34 | 159.5 | .35 | 162.5 |
| 5935.0000 | .33 | 148.2 | .35 | 158.7 |
| 5940.0000 | .33 | 137.5 | .34 | 155.0 |
| 5945.0000 | .31 | 126.3 | .33 | 151.6 |

Modified to Print Linear Magnitude Coefficients

FILTER 11246B

| FREQUENCY MHz | SWR - IN S11 | | SWR - OUT S22 | |
|------------------|-----------------|-----|------------------|-----|
| | MAG | ANG | MAG | ANG |
| 5875.0000 | 4.64 | | 5.26 | |
| 5880.0000 | 3.23 | | 3.66 | |
| 5885.0000 | 2.28 | | 2.57 | |
| 5890.0000 | 1.66 | | 1.91 | |
| 5895.0000 | 1.31 | | 1.55 | |
| 5900.0000 | 1.26 | | 1.46 | |
| 5905.0000 | 1.42 | | 1.56 | |
| 5910.0000 | 1.61 | | 1.70 | |
| 5915.0000 | 1.78 | | 1.85 | |
| 5920.0000 | 1.90 | | 1.96 | |
| 5925.0000 | 1.97 | | 2.03 | |
| 5930.0000 | 2.01 | | 2.07 | |
| 5935.0000 | 2.01 | | 2.06 | |
| 5940.0000 | 1.97 | | 2.03 | |
| 5945.0000 | 1.92 | | 1.98 | |

Modified to Print Standing Wave Ratio

FILTER 11246B

| FREQUENCY MHz | NORM IMPED-IN S11 | | NORM IMPED-OUT S22 | |
|------------------|----------------------|-----|-----------------------|-----|
| | R | +jX | R | +jX |
| 5875.0000 | .33 | .7 | .23 | .5 |
| 5880.0000 | .57 | .8 | .36 | .5 |
| 5885.0000 | .98 | .8 | .52 | .5 |
| 5890.0000 | 1.36 | .5 | .67 | .4 |
| 5895.0000 | 1.31 | -.0 | .74 | .3 |
| 5900.0000 | 1.03 | -.2 | .71 | .1 |
| 5905.0000 | .80 | -.2 | .65 | .1 |
| 5910.0000 | .66 | -.2 | .59 | .0 |
| 5915.0000 | .57 | -.1 | .54 | .1 |
| 5920.0000 | .53 | -.0 | .51 | .1 |
| 5925.0000 | .51 | .1 | .50 | .1 |
| 5930.0000 | .51 | .1 | .49 | .1 |
| 5935.0000 | .53 | .2 | .50 | .1 |
| 5940.0000 | .56 | .3 | .51 | .2 |
| 5945.0000 | .61 | .3 | .53 | .2 |

Modified to Print Normalized Impedance

Figure 6. Standard and Modified Printed Outputs.

FILTER 11246B

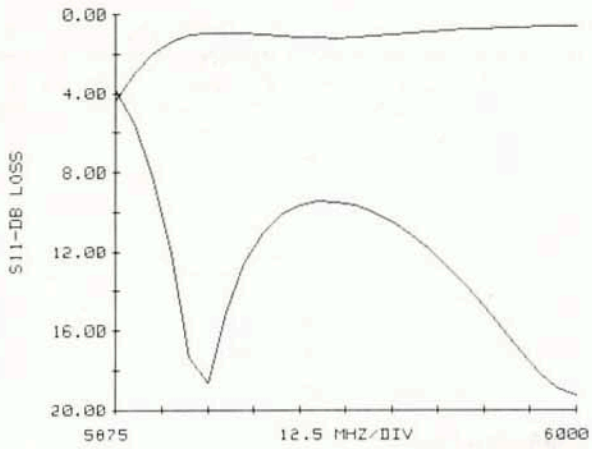

Plotted Output to 9845B Thermal Printer

FILTER

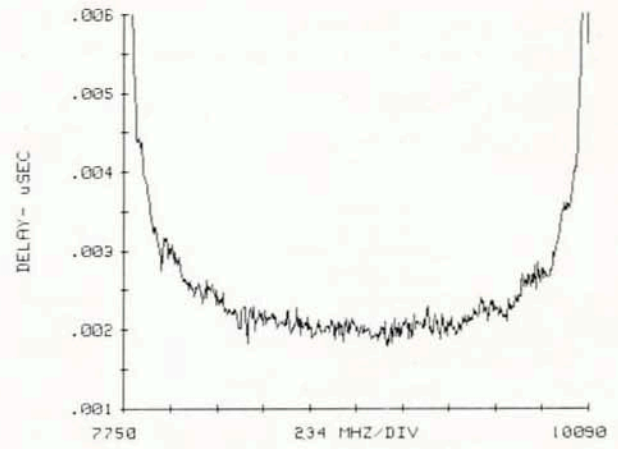

Aperture = 1 = 4.5 MHz
 $\Delta\phi = 3$ degrees

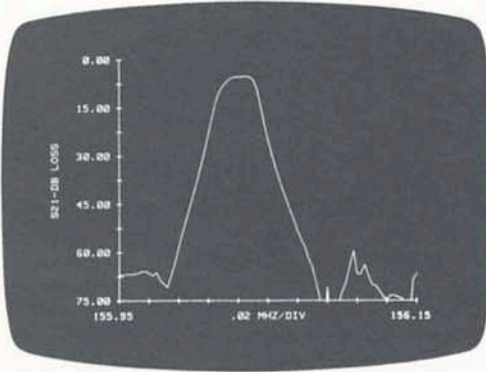

Plotted Output to 9845B CRT

FILTER

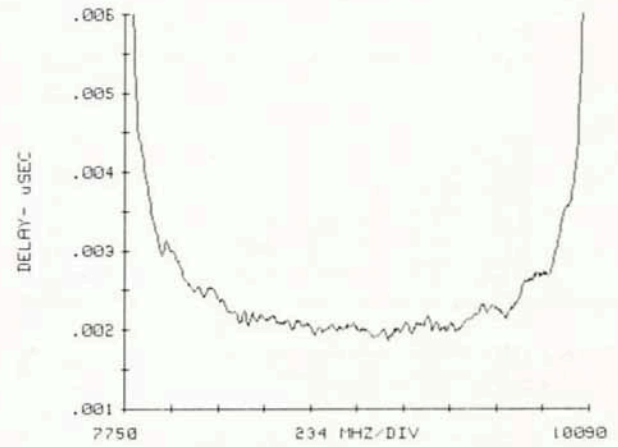

Aperture = 5 = 22.5 MHz
 $\Delta\phi = 15$ degrees

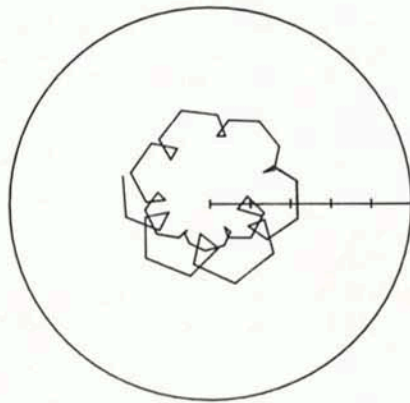

S11: POLAR FULL SCALE .1
Plotted Output to 9872B Graphics Plotter

FILTER

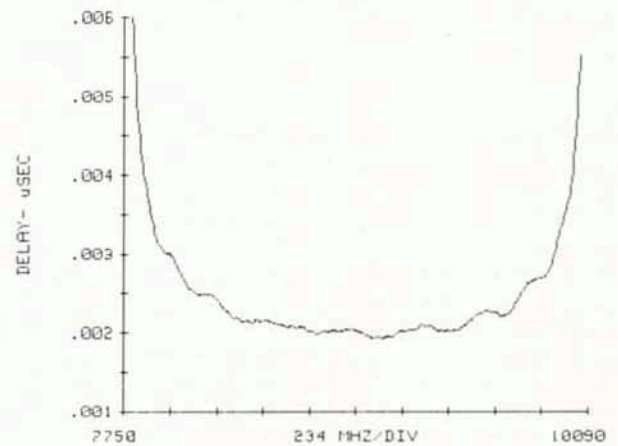

Aperture = 15 = 67.5 MHz
 $\Delta\phi = 45$ degrees

Figure 7. Standard and Special Plotted Outputs.

CONFIGURING THE SYSTEM

Following is a suggested equipment list for the complete multi-band system with source phase-lock as shown in Figure 4.

In a single band system, shown in Figure 1 or 2, the 8746B S-Parameter Test Set can be used in place of the

8743A or 8745A. When using the 8746B, the system can operate using the standard software in either of two ranges: 2000 to 12400 MHz using the 86290B sweeper plug-in, or 500 to 2000 MHz using the 86222B sweeper plug-in.

Table 1. Suggested Equipment List.

NETWORK ANALYZER

- 8410B Network Analyzer
 - Option H17 External VCO Switch
 - Option C06 Rear Panel Input for 8411A
 - Option 908 Rack Flange Kit
- 8411A Harmonic Frequency Converter
 - Option 018 0.11 to 18 GHz
- 8412A Phase-Magnitude Display
- 8418A Auxiliary Display Holder
 - Option H01 Programmable IF Attenuator
 - Option 908 Rack Flange Kit
- 8414A Polar Display
 - Option H07 Remote Beam Center

TEST SETS

- 8327A Test Set Selector
 - Option 908 Rack Flange Kit
 - Note:** 8327A includes 9100-3567 140 MHz Bandpass Filter required for operation above 2 GHz, and 08327-20015 Test Set RF Cable which connects 8743A and 8620C/86290B.

0.11 to 2 GHz Frequency Range

- 8745A S-Parameter Test Set
 - Option 908 Rack Flange Kit
- 11857A Test Set Extension Cables

2 to 18 GHz Frequency Range

- 8743A Reflection/Transmission Test Set
 - Option 018 2 to 18 GHz Operation
 - Option K07 Reference Line for 11610B Cable
 - Option 908 Rack Flange Kit
- 11610B Test Set Extension Cable

SOURCES

Mainframes (two each for multi-band)

- 8620C Sweep Oscillator Mainframe
 - Option 011 HP-IB Interface
 - Option H07 Rear Panel Sweep Output
 - Option 908 Rack Flange Kit

0.11 to 2 GHz Frequency Range

- 86222B 0.1 to 2.4 GHz Plug-in
 - Option 002 70 dB Attenuator
 - Option 004 Rear Panel RF Output
- 11609A Option K02 Test Set RF Cable

2 to 18 GHz Frequency Range

- 86290B 2.0 to 18.6 GHz Plug-in
 - Option 004 Rear Panel RF Output

SOURCE PHASE-LOCK SUBSYSTEM

- 3335A Synthesizer, 200 Hz to 80 MHz
 - Option 908 Rack Flange Kit
- 8447C Amplifier
- 8709A Synchronizer
 - Option H17 20.278 MHz Reference
- 11859A Amplifier/Switch
 - Note:** 11859A includes 10515A Frequency doubler and 0955-0217 BNC 10dB Attenuator

HP-IB ACCESSORIES

- 59306A Relay Actuator
- 59313A Four Channel Analog to Digital Converter

CONTROLLER

- 9845T Desktop Computer System
 - Option 312 Input/Output ROM
 - Option 560 U.S. Paper Size
- 98034A Option 445 HP-IB Interface System Controller Table

CALIBRATION STANDARDS

APC-7® and Type N

- 11866A APC-7 Calibration Kit (includes short, shielded open and termination)
- 11567A 20 Centimeter Air Line
- 85032A 50 Ohm Type N Calibration Kit (includes short and 50 ohm termination)
 - Option 001 Male and Female Shielded Opens
- 905A Coaxial Sliding Load (APC-7 and Type N)

SMA

- 85033A 50 Ohm SMA Calibration Kit (includes short and 50 ohm termination)
 - Option 001 Male and Female Shielded Opens
- 911A Coaxial SMA Sliding Load

ACCESSORIES

- 8492A Option 010 10 dB Coaxial Attenuator (APC-7)
- 1250-0781 BNC Tee (2 ea.)
- 11170A BNC Cables, 0.3 m (4 ea.)
- 11170C BNC Cables, 1.22 m (10 ea.)
- 10631A HP-IB Cables, 1 m (2 ea.) (other HP-IB cables supplied with instruments)

SOFTWARE

- 11863D Accuracy Enhancement Program

"APC-7" is a registered trademark of the Bunker-Ramo Corporation.

RACK LAYOUT

System instruments can be rack mounted as shown in Figure 8, or may be stacked on a suitable table top. In general, equipment placement is not critical except where limited by supplied RF cables as in the following cases.

1. For 8327A Test Set Selector equipped systems the sources, test sets, and test set selector must be arranged as shown below.

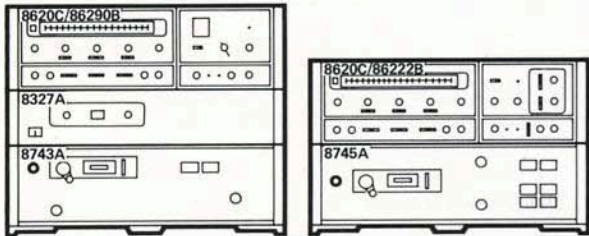

2. The 8418A Option H01 Auxiliary Display Holder must be mounted directly above or below the 8410B mainframe. Maximum length of the three double-shielded BNC cables for reference and test magnitude and phase interconnection is less than one meter.

3. The 8411A to 8410B cable is six feet long. For 8327A equipped systems the 8411A is mounted inside the 8327A and therefore the 8410B must be located within five feet of the 8327A.

4. The 8709A Option H17 Synchronizer and 11859A Amplifier Switch can be rack mounted using the HP 5060-8762 Rack Adapter.

5. The 59306A Relay Actuator and 59313A A/D Converter can be rack mounted using the 5061-0096 Rack Mounting Shelf.

6. The 8447C Amplifier can be rack mounted using the HP 5060-8764 Rack Frame.

Prepare the system for operation by making the necessary cable connections, control settings, and functional checks described in the following paragraphs. Refer to the individual instrument manuals for detailed installation requirements of each instrument.

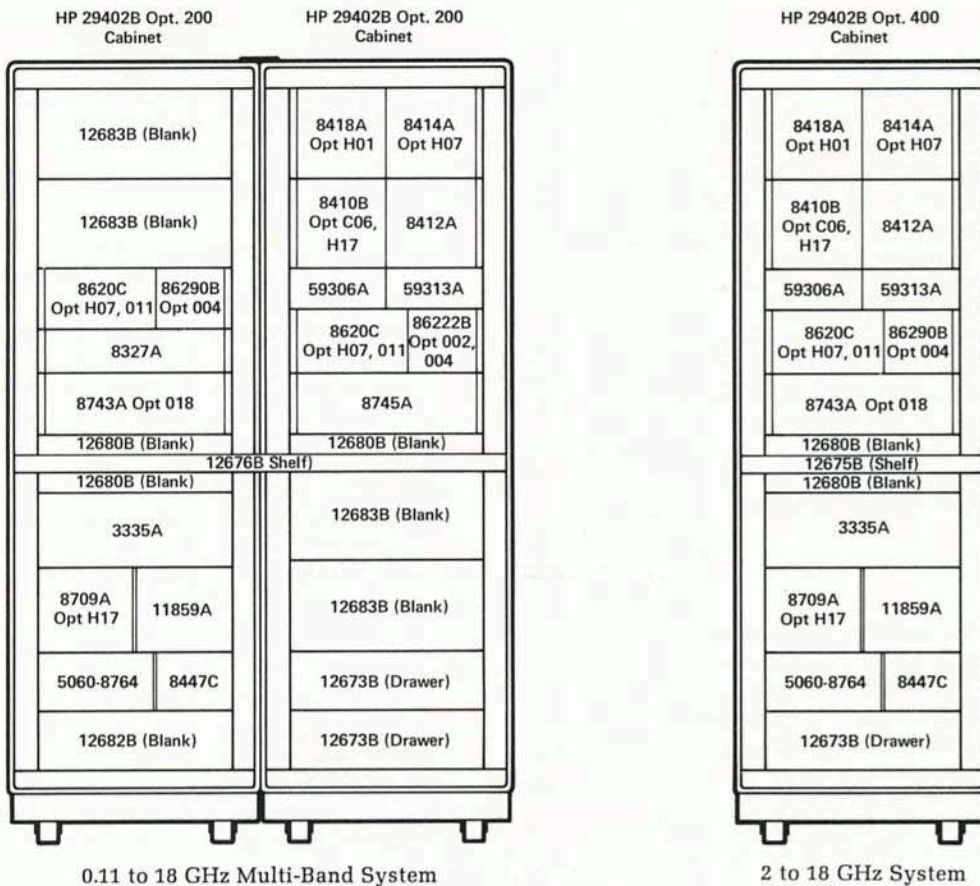

Figure 8. Recommended Rack Configurations.

SELECT CODES AND HP-IB ADDRESSES

The HP-IB uses Select Code 7. Table 2 lists the HP-IB addresses used for system instruments in the standard system software.

Table 2. Instrument HP-IB Addresses.

| INSTRUMENT | HP-IB ADDRESS |
|--------------|---------------|
| 8620C (both) | 06 |
| 59306A | 16 |
| 59313A | 10 |
| 3335A | 04 |

A/D CONVERTER RANGE SELECTION

The 59313A Analog to Digital Converter uses the following internal RANGE jumper settings:

Channels 1,2,3 ME (Medium, 2.5V full scale)
 Channel 4 HI (High, 10V full scale)

INSTALL PLUG-INS

Install the 8414A Option H07 Polar Display in the 8418A Option H01 Auxiliary Display Holder; the 8412A Phase-Magnitude Display in the 8410B Network Ana-

lyzer Mainframe, and the Sweeper Plug-in(s) in the 8620C Mainframe(s).

CONNECT SIGNAL, HP-IB AND POWER CABLES

A very important consideration is selection of the cable(s) used to connect the test device to the test set. The semi-rigid test port extension cables in the current recommended equipment list provide a convenient means to make two port measurements. These cables are designed to have stable magnitude and phase response characteristics with normal use. However, these characteristics will be degraded by excessive flexing. Figure 9 shows recommended cable configurations. For tests using the 8743A, install the HP 8492A-010 10 dB coaxial attenuator as shown to improve the transmission return port match and make it less variable with return cable flexure. Tests using the 8745A or 8746B test sets do not use the 10 dB attenuator.

Figure 10 shows all signal cable connections for the basic system as well as additional cables required for the Source Phase-lock Subsystem. Figure 11 shows all signal cable connections for the complete system equipped for multi-band operation and source phase-lock.

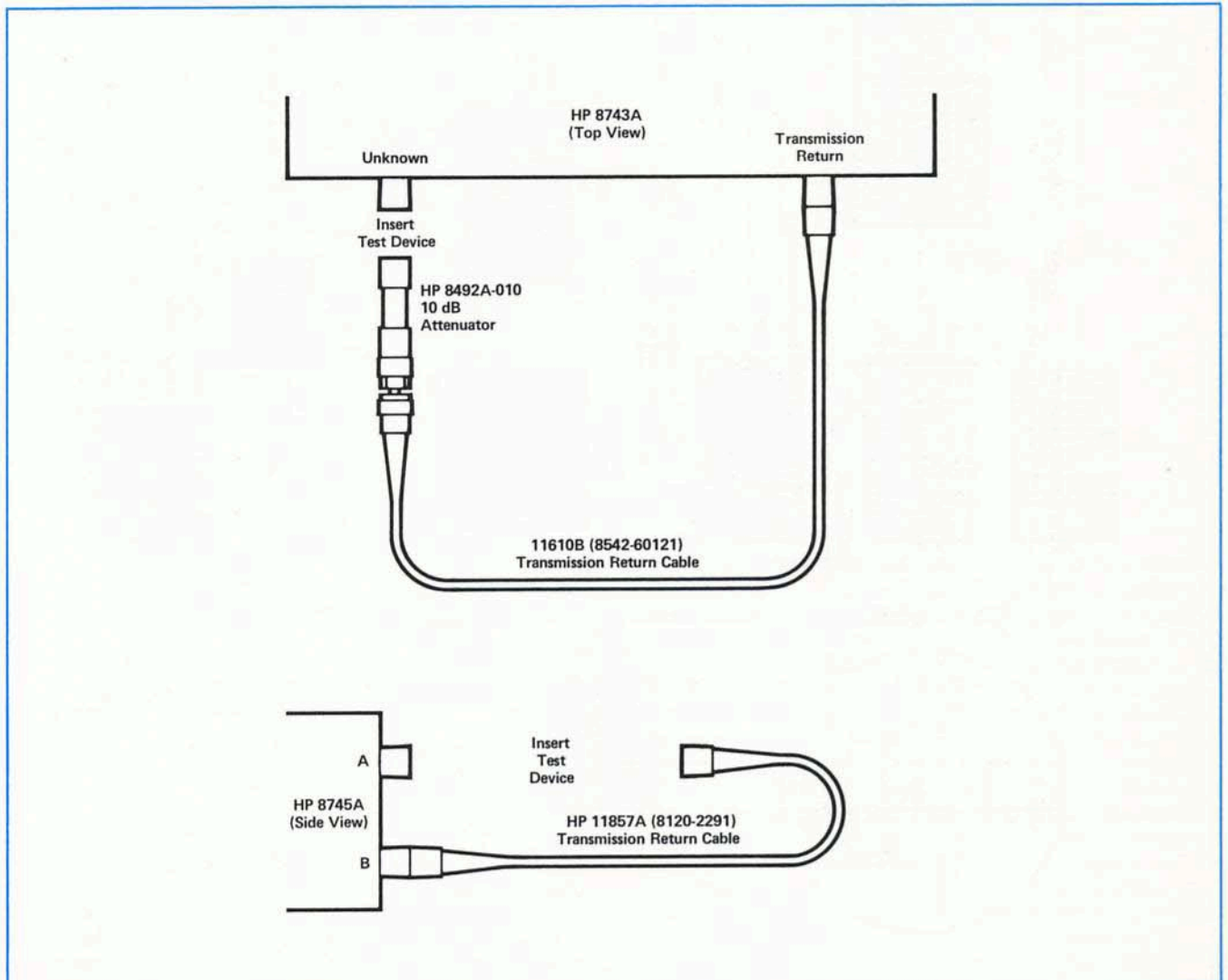

Figure 9. Recommended Transmission Return Cable Configurations for Coaxial Measurements.

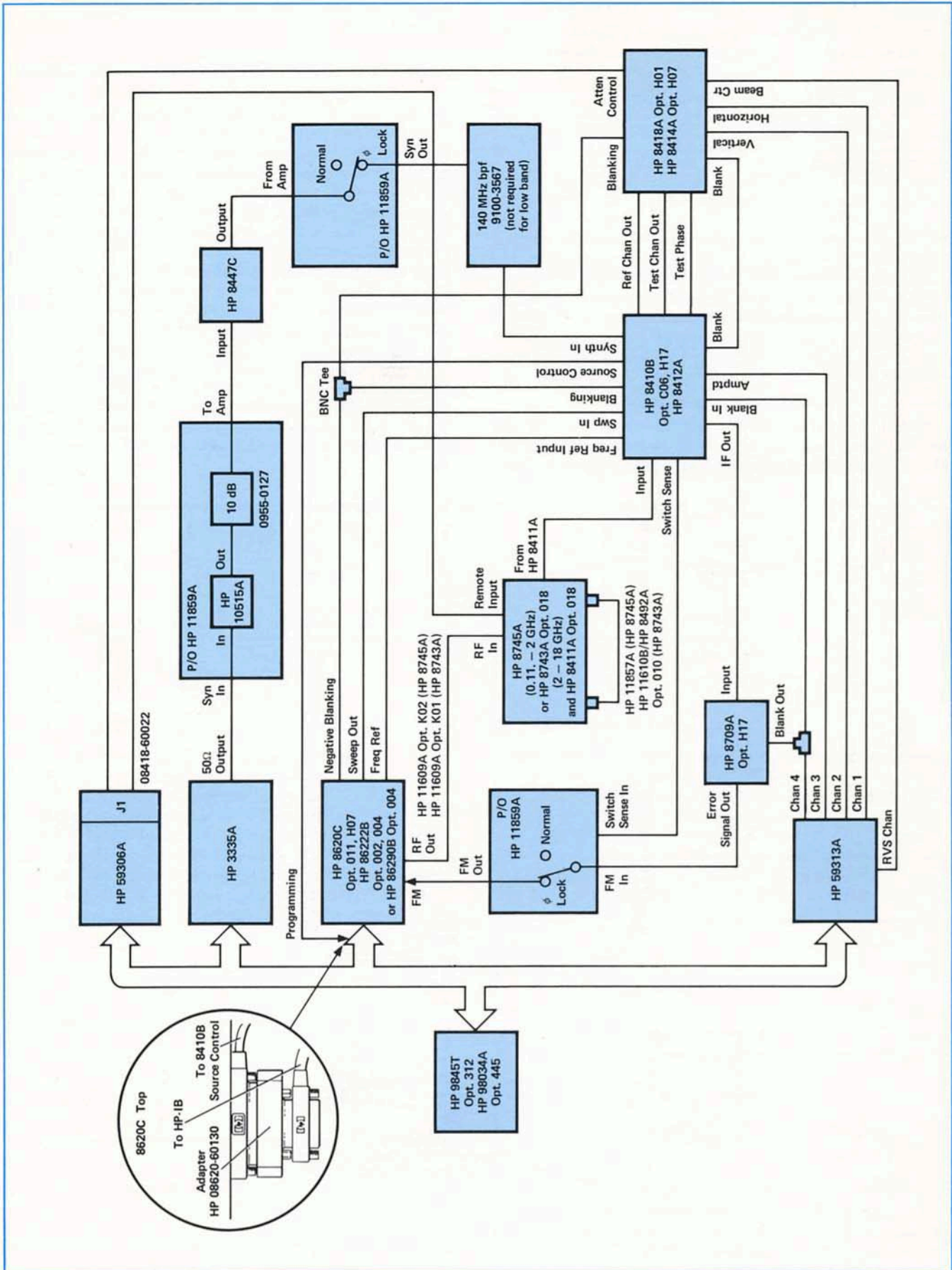

Figure 10. Basic Single Band System Cabling Diagram (with Source Phase-Lock Subsystem).

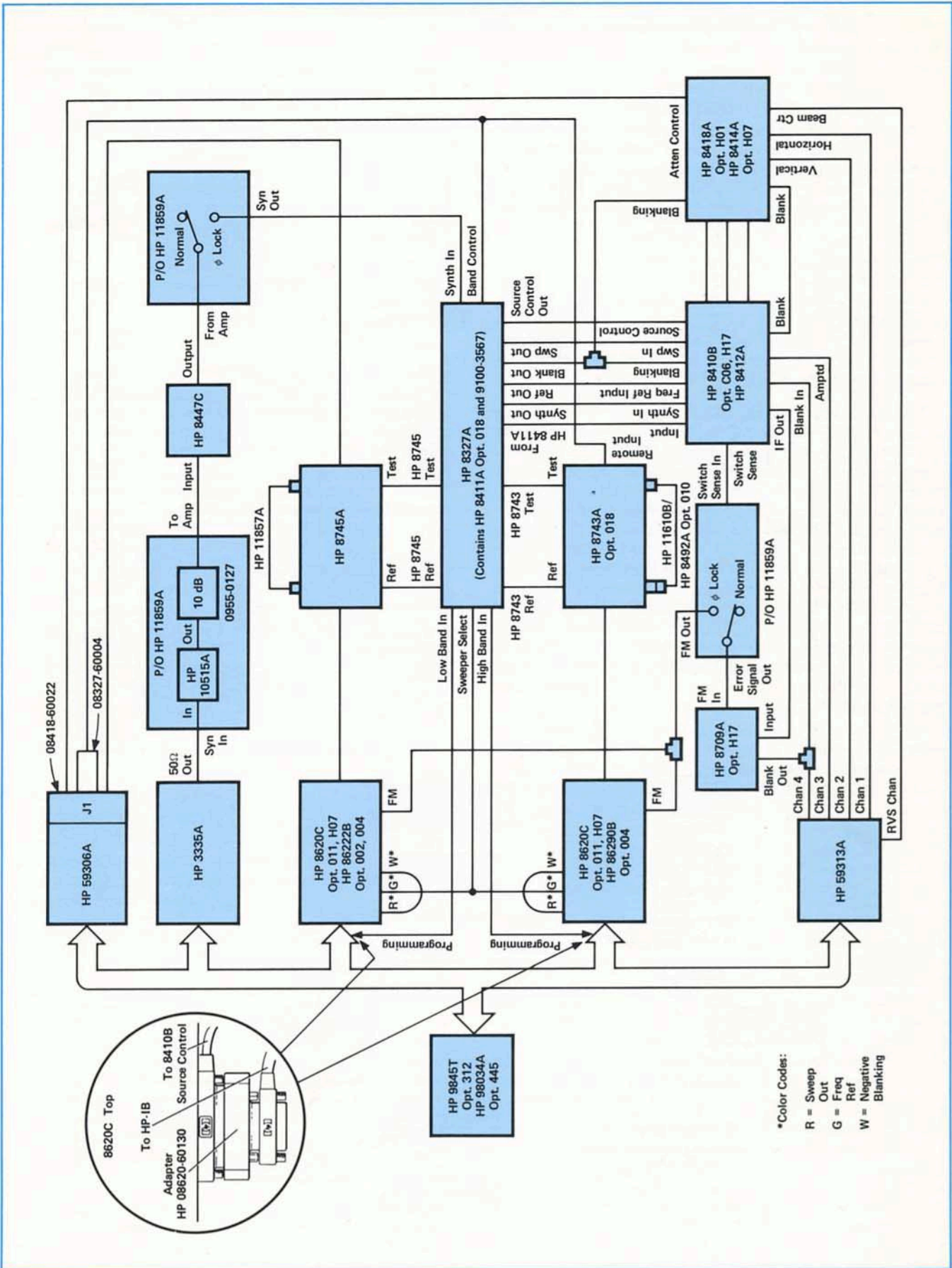

Figure 11. Complete System Cabling Diagram (Multi-Band and Source Phase-Lock)

CONTROL SETTINGS

Turn on power to all system instruments, then set the instrument controls as listed in Table 3.

SYSTEM OPERATION

The system does not require detailed manual magnitude, phase, and electrical length calibration prior to automatic operation. It is only necessary that the system maintains proper phase-lock and has proper reference channel power level over the frequency range of interest.

The program outputs prompts and operator instruction to the display. Respond by typing upper or lower case characters or numbers and then pressing CONT, or by performing the indicated operation and then pressing CONT. Figure 12 presents a flowgraph of the program operating sequence to describe the program prompts and instructions.

The accuracy enhancement program (11863C for 9825A; 11863D for 9845B) is fully documented in its own Operating and Programming Manual, which includes examples showing some special program modifications (for example, adapting the program for waveguide measurements). Due to memory limitation, the 9825A version of the program does not include some features shown in Figure 12. These are: ability to specify multiple start, stop, step sequences; 8414A Polar Display quadrature error calibration; the number of test frequencies is limited to 31 without external storage (500 in the 9845B version); automatic assignment of open circuit capacitance variables for APC-7, Type N, and SMA test port adapters; automatic computed group delay; and choice of hard or soft copy printed and plotted outputs.

Table 3. Control Settings for Normal Operation.

| Instrument | Control | Setting |
|---------------------------------|---|---|
| 8620C Front Panel | MARKER SWEEP MODE TRIGGER TIME MARKERS BAND (86290B only) START/STOP MARKERS | Press to light AUTO INT 1 - 10 sec OFF 2 - 18.6 GHz range of interest |
| 8620C Rear Panel | 1 kHz SQ WAVE RF BLANKING DISPLAY BLANKING | OFF OFF ON |
| 86222B Sweeper Plug-in | POWER LEVEL RF FREQ MHz MODE ALC FM/NORM/PL (rear) SLOPE | +6 dBm ON OFF INT INT PL Fully CCW (OFF) |
| 86290B Sweeper Plug-in | POWER LEVEL RF NORM/FM/PL (rear) SLOPE | MAX (use PEAK) ON PL Fully CW |
| 8410B Front Panel | FREQ RANGE Test Channel Gain SWEEP STABILITY NORMAL/ ϕ LOCK | AUTO 60 CW (detent) ϕ LOCK |
| 8412A Display | MODE AMPL dB/DIV BW (kHz) | AMPL 10 10 |
| 8709A Opt H17 Rear Panel | RANGE | 6 MHz/VOLT |
| 3335A Synthesizer | OUTPUT | 50 |

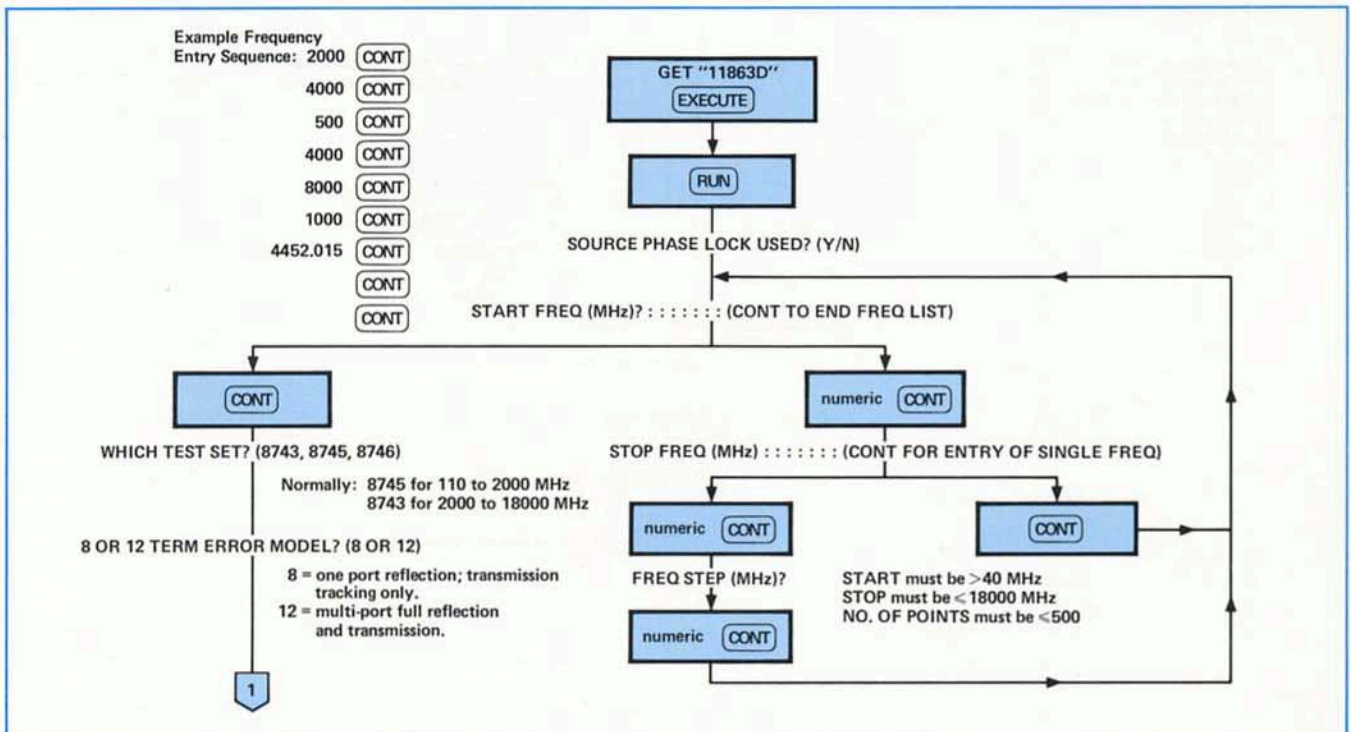

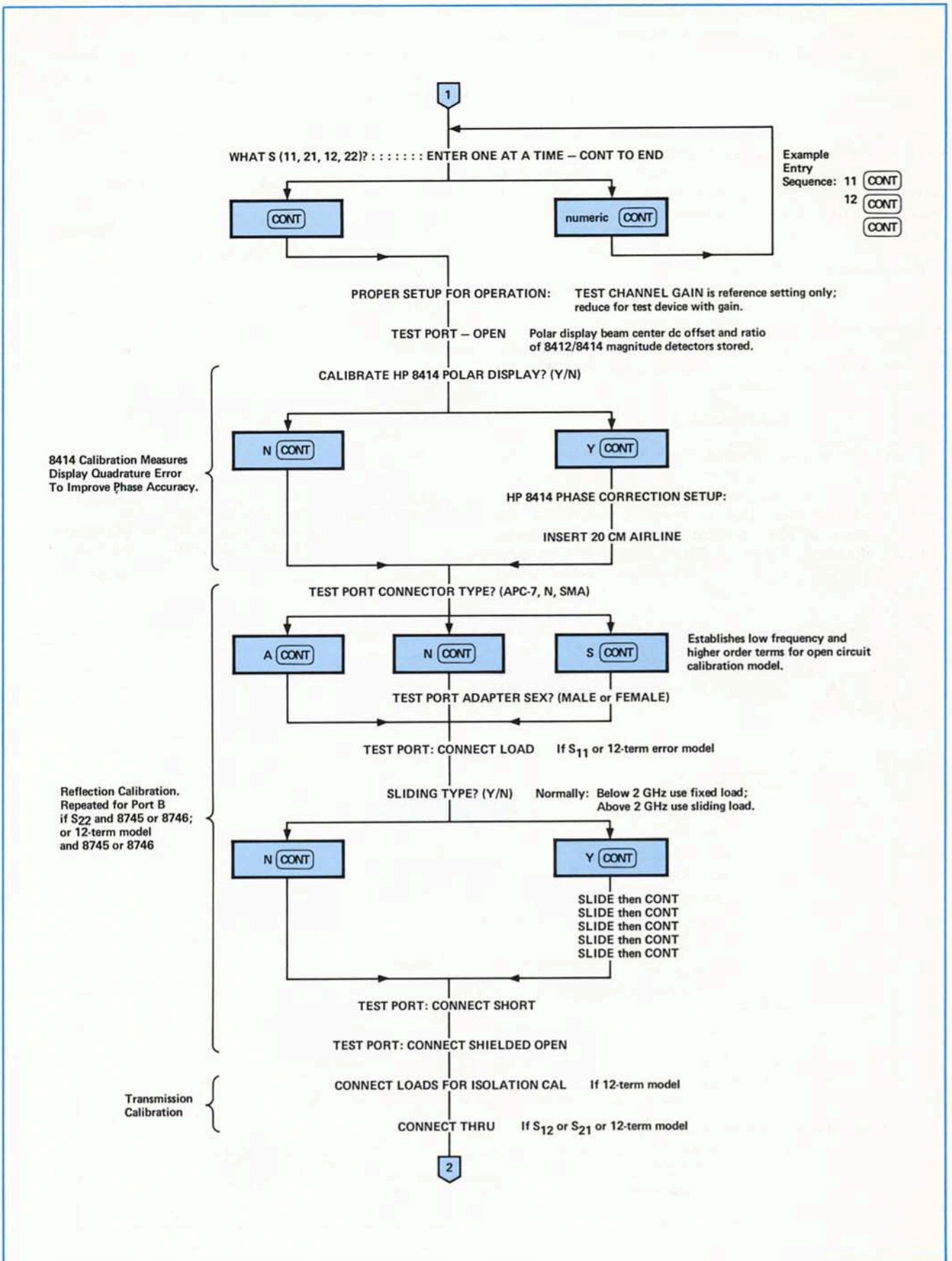

Figure 12. Program Operation (2 of 3) Calibration.

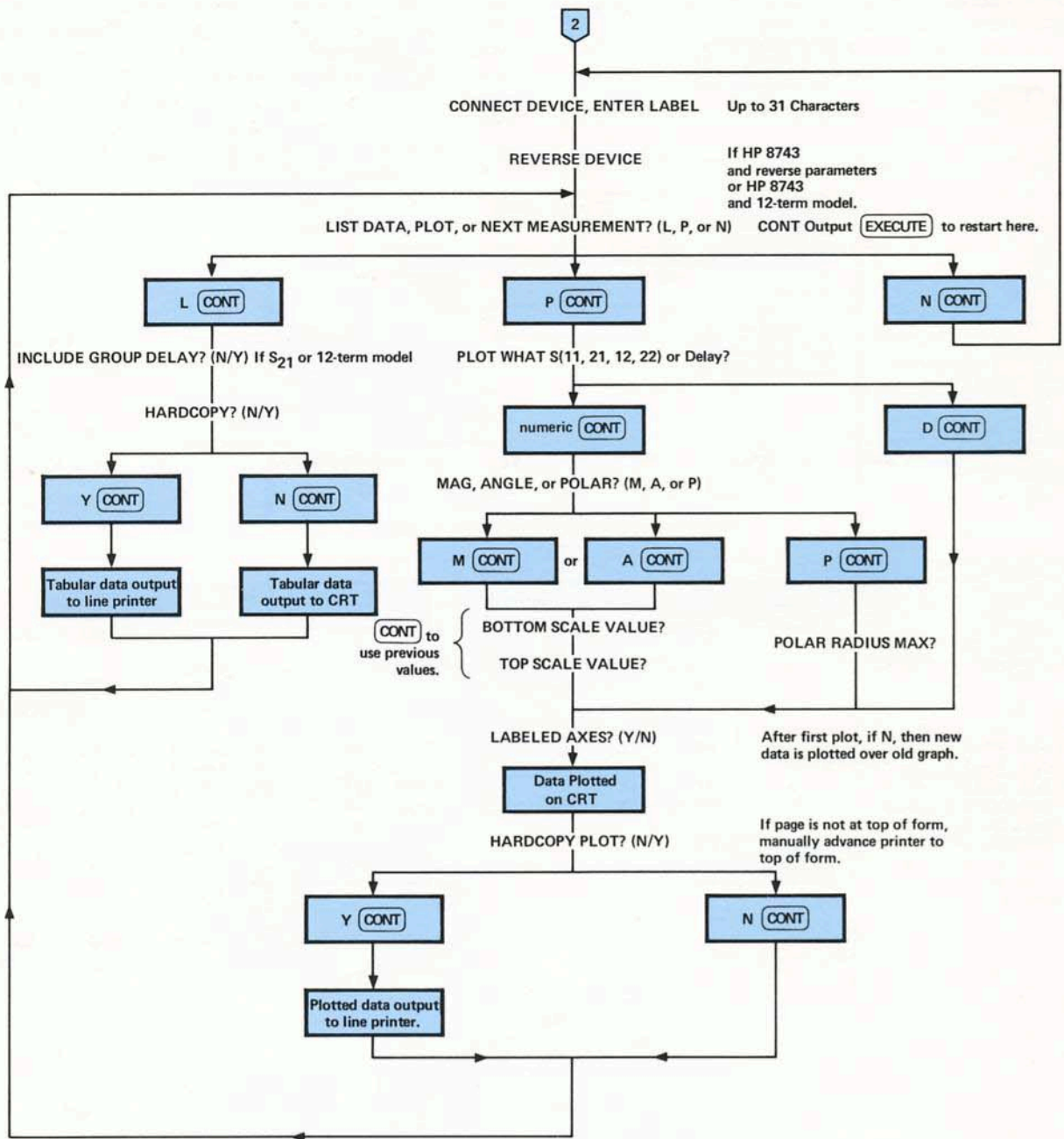

Figure 12. Program Operation (3 of 3) Measurement.

SYSTEM FUNCTIONAL CHECK

Simple, readily available devices should be measured periodically to verify system hardware and software performance. Table 4 suggests use of the 20 centimeter air line and the short circuit supplied with the system. Typical measurement results along with typical maximum variations are shown in Figure 13.

The air line, when measured with the Twelve-term error model, should exhibit reasonable return loss, low insertion loss, and good phase linearity.

The short circuit S₁₁ data provides a measure of system repeatability between calibration and measurement, and more important, the S₂₁ magnitude measurement defines the system noise floor. While measurements on these two devices do not absolutely guarantee total

system performance, they provide reasonable confidence that no major problem exists.

For more detailed examination of the system's performance characteristics, measure one or more standard devices and compare current results with historical data. There are a number of standard devices available which are specified in terms of insertion loss, return loss, transmission or reflection coefficients, electrical length, or group delay. It is advisable that you select and maintain one or more standard devices (e.g. attenuator, standard mismatch, offset short, etc.) used exclusively for measurement at periodic intervals to test system performance.

Table 4. Sample System Functional Tests.

| Test Number | Test Frequencies | Test Set | Error Model | 8414A Calibration | Load For Calibration | Test Device |
|-------------|---------------------------|----------|-------------|-------------------|----------------------|---------------|
| 1 | 2000 to 1800 Step 2000 | 8743 | 12 | Yes | Sliding | 20 cm Airline |
| | | | | | | Short Circuit |
| 2 | 200 to 2000 | 8745 | 12 | Yes | Fixed | 20 cm Airline |
| | | | | | | Short Circuit |

| Test 1 | | | | | | | | | |
|----------------|----------------|-----------------|------|------------------|----------------|----------------|--------------|--------|-----------------|
| 20 cm Air Line | | | | | Short Circuit. | | | | |
| FREQUENCY | RETURN LOSS-IN | LOSS-FORWARD | | | FREQUENCY | RETURN LOSS-IN | LOSS-FORWARD | | |
| MHz | DB | ANG | DB | ANG | MHz | DB | ANG | DB | ANG |
| 2000.0000 | 56.99 | -149.3 | .05 | -126.8 | 2000.0000 | -.00 | -180.0 | 87.81 | 95.4 |
| 4000.0000 | 53.01 | -151.7 | .05 | 107.5 | 4000.0000 | -.00 | -180.0 | 93.16 | -68.9 |
| 6000.0000 | 43.09 | 64.5 | .07 | -17.6 | 6000.0000 | .05 | -179.9 | 93.98 | 47.1 |
| 8000.0000 | 38.83 | 109.3 | .10 | -144.5 | 8000.0000 | .03 | 180.0 | 78.86 | 95.0 |
| 10000.0000 | 42.25 | 99.7 | .11 | 90.3 | 10000.0000 | .00 | 180.0 | 80.36 | 5.7 |
| 12000.0000 | 33.35 | 54.4 | .16 | -35.7 | 12000.0000 | .01 | -179.9 | 75.67 | -12.7 |
| 14000.0000 | 39.03 | 87.4 | .15 | -161.9 | 14000.0000 | .05 | 179.8 | 75.03 | -10.2 |
| 16000.0000 | 47.30 | 10.1 | .18 | 71.4 | 16000.0000 | .00 | 179.9 | 76.43 | 88.8 |
| 18000.0000 | 34.12 | 24.5 | .23 | -54.5 | 18000.0000 | .00 | 179.9 | 81.55 | -144.7 |
| | >26dB | Not Predictable | 0 dB | ≈24° per 100 MHz | | 0 ± 0.1 dB | ±180° ± 1° | >50 dB | Not Predictable |

| Test 2 | | | | | | | | | |
|----------------|----------------|-----------------|------|------------------|----------------|----------------|--------------|--------|-----------------|
| 20 cm Air Line | | | | | Short Circuit. | | | | |
| FREQUENCY | RETURN LOSS-IN | LOSS-FORWARD | | | FREQUENCY | RETURN LOSS-IN | LOSS-FORWARD | | |
| MHz | DB | ANG | DB | ANG | MHz | DB | ANG | DB | ANG |
| 200.0000 | 51.52 | -79.4 | .01 | -49.0 | 200.0000 | .00 | -179.3 | 79.69 | 164.3 |
| 500.0000 | 48.92 | -179.3 | .00 | -121.4 | 500.0000 | .00 | 180.0 | 87.04 | -58.7 |
| 800.0000 | 50.44 | 91.8 | .05 | 165.5 | 800.0000 | .01 | 180.0 | 81.50 | 163.8 |
| 1100.0000 | 48.59 | -102.1 | .03 | 91.4 | 1100.0000 | .00 | -180.0 | 88.05 | 166.6 |
| 1400.0000 | 54.64 | 117.6 | .05 | 19.2 | 1400.0000 | .00 | 179.9 | 87.82 | 4.5 |
| 1700.0000 | 51.44 | -158.6 | .03 | -52.8 | 1700.0000 | .00 | 179.9 | 91.68 | -148.2 |
| 2000.0000 | 45.18 | 153.9 | .06 | -125.5 | 2000.0000 | .00 | 180.0 | 90.72 | 59.0 |
| | >32dB | Not Predictable | 0 dB | ≈24° per 100 MHz | | 0 ± 0.1 dB | ±180° ± 1° | >55 dB | Not Predictable |

Figure 13. Typical Functional Check Results.

If you suspect that the system is not operating properly, the first three areas to check are:

1. Adapters—Are the adapters you are using to connect to the test device in good condition? Eliminate the adapters, calibrate the system in APC-7 and measure a test device with APC-7 connectors.

2. Transmission Return Cable—Check that the transmission return cable is in good condition and showing minimal changes in its magnitude and phase characteristics as it is tapped or flexed during use. Set up the system for manual operation at a suitable sweep width then view the transmission magnitude and phase response as the cable is flexed slightly.

3. Test Set Repeatability—Check that the test set repeatability (switching between S-parameters) is acceptable. Set up the system for manual operation and view transmission and reflection magnitude and phase as the test sets are switched using buttons 2 and 3 of the 59306A.

The following paragraphs describe a combination of manual checks, one line program statements, and a simple program to perform checks which verify that cable connections are properly made and that the system instruments are operating and adjusted properly.

MANUAL CHECKS

If any of the system instruments are in the Remote mode, press the 9845T CONTROL and STOP keys. This should place all instruments in the LOCAL state.

NOTE

If the system is equipped for source phase-lock, set the 8410B NORMAL/ ϕ LOCK Switch to NORMAL.

Figure 14 shows which of the 59306A Relay Actuator switches control test set and IF attenuator switching. Press the 59306A LOCAL button, then check switching of the 8327A, 8743A, 8745A, and 8418A Option H01. Since the 8327A, the 8743A and the 8745A front panel switches are disabled by connection of the remote control cables, buttons on the 59306A provide the only manual means of selection.

The 8327A and test sets should switch as shown. When you increase 8418A Option H01 IF attenuation using buttons 4, 5 and 6, an increase in 8410B Test Channel Gain should move the polar trace back to its original position.

Check receiver phase-lock with the sweeper in its CW mode. The recommended position of the 8410B SWEEP STABILITY control for automatic operation is CW. In this position fast sweeps may show dropouts due to loss of receiver phase-lock. If so, slow the sweep to achieve a continuous trace.

PROGRAMMING CHECKS

Program the system instruments using statements listed in Table 5. Type each line then press EXECUTE

and verify that the described functions are programmed. After the line is executed, you can press RECALL to recall the line for editing.

Table 5. Functional Check Program Statements.

| Statement | Function |
|--|---------------------------------|
| 8620 Sweeper | |
| Use 8410B Test Channel Gain to position the trace vertically so it is visible on the 8412A. These statements program the 8620C to 50% of the selected band range in the CW mode. The trace should move to the horizontal midpoint of the screen. | |
| 86290B (Select 8327A High Band) | |
| OUTPUT 706; "M1B1V5000E" | Band 1, 4.1 GHz |
| OUTPUT 706; "M1B2V5000E" | Band 2, 9.2 GHz |
| OUTPUT 706; "M1B3V5000E" | Band 3, 15.3 GHz |
| 86222B (Select 8327A Low Band) | |
| OUTPUT 706; "M1V5000E" | 1 GHz |
| M1 selects the CW mode; V5000 programs 50% of selected band; B1, B2, and B3 select 86290B band (86290B front panel BAND indicators should switch). Proper frequency programming verifies the HP-IB; proper trace position and phase-lock verifies connections between the sweeper and 8410B/8412A. | |
| 59306A Relay Actuator | |
| Execute the statement and check that the relay actuator and controlled instrument are set to the specified state. Proper 59306A programming verifies the HP-IB interface; proper instrument switching verifies connections between the 59306A and the instrument. | |
| OUTPUT 716; "A123456" | All buttons lighted |
| OUTPUT 716; "B123456" | All buttons extinguished |
| Test Sets | |
| 8754A/8746B 8743A | |
| OUTPUT 716; "B23" | S11 Reflection |
| OUTPUT 716; "A2B3" | S21 Transmission |
| OUTPUT 716; "A3B2" | S12 Reflection |
| OUTPUT 716; "A23" | S22 Transmission |
| 8418A IF Attenuation | |
| OUTPUT 716; "B456" | 0 dB |
| OUTPUT 716; "A4B56" | 10 dB |
| OUTPUT 716; "A5B46" | 20 dB |
| OUTPUT 716; "A45B6" | 30 dB |
| OUTPUT 716; "A6B45" | 40 dB |
| OUTPUT 716; "A46B5" | 50 dB |
| 8327A Test Set Selector | |
| OUTPUT 716; "A1" | High |
| OUTPUT 716; "B1" | Low |
| 3335A Synthesized Signal Generator | |
| OUTPUT 704; "CA13KF70M" | 70 MHz, +13 dBm |
| Verify programming by pressing 3335A LOCAL then press AMPLITUDE (display should read +13 dBm) and FREQUENCY (display should read 70 MHz). | |
| 8414A Option H07 Polar Display | |
| OUTPUT 710; "N" | Beam moves to BEAM CTR position |
| OUTPUT 710; "O" | Normal display operation |

| 1 | 2 | 3 | 4 | 5 | 6 |
|----------------------------------|---|------------------------|---|------------------------|------------------------|
| 8327A High/Low Band Select | 8743A OUT = Reflection IN = Transmission | Not Used | IN = 10dB OUT = 0dB | IN = 20dB OUT = 0dB | IN = 40dB OUT = 0dB |
| IN = HIGH OUT = LOW | 8745A/8764B OUT = S ₁₁ = IN = S ₂₁ = OUT = S ₁₂ = IN = S ₂₂ = | OUT OUT IN IN | Select Combinations for 0, 10, 20, 30, 40, and 50 dB IF attenuation. | | |

Figure 14. Test Set and IF Attenuator Switching Using 59306A.

To check A/D Converter calibration refer to Figure 15.

To verify the A/D connections between the 59313A, the 8410B, and the 8418A Option H01, set up the system to achieve receiver phase-lock in either high or low

1. Enter calibration program into memory:

```

10 Adcal: 1
20 OUTPUT 710;"H1AJ"
30 A=ROTATE(READBIN(710),8)+READBIN(710)
40 OUTPUT 710;"H2AJ"
50 B=ROTATE(READBIN(710),8)+READBIN(710)
60 OUTPUT 710;"H4AJ"
70 C=ROTATE(READBIN(710),8)+READBIN(710)
80 OUTPUT 710;"H8AJ"
90 D=ROTATE(READBIN(710),8)+READBIN(710)
100 DISP A,B,C,D
110 GOTO 20
120 END
    
```

2. Remove 59313A Channel 1, 2, 3, and 4 phone plugs from their rear panel receptacles.

3. Press RUN to execute program. Display shows A/D converter output values:

| Channel 1 | Channel 2 | Channel 3 | Channel 4 |
|-----------|-----------|-----------|-----------|
| XXXX.XX | XXXX.XX | XXXX.XX | XXXX.XX |

4. Set rear panel CAL switch to 0 (zero). Adjust Channel 1, 2, 3, and 4 front panel ZERO controls for -0.00.

5. Set rear panel CAL switch to -1. Adjust Channel 1, 2, and 3 front panel GAIN controls for -400.

6. Set rear panel CAL switch to -5. Adjust Channel 4 front panel GAIN control for -800.

7. Press STOP.

8. Reconnect Channel 1 (8418A Option H01 HORIZONTAL), Channel 2 (8418A Option H01 VERTICAL), Channel 3 (8410B AMPLITUDE), and Channel 4 8410B Option H17 BLANK IN) phone plugs to the 59313A.

Figure 15. 59313A A/D Converter Calibration Program.

band with the sweeper in its CW mode, the test set in its reflection mode, and a short or open circuit at the test port. Select appropriate 8410B Test Channel Gain and 8418A IF attenuation so that the trace is visible on both displays. Now, run the A/D converter calibration program and refer to Figure 16. Use the sweeper CW control, 8410B Test Channel Gain, 8418A IF attenuation, and the test set REFERENCE PLANE EXTENSION to move the dot on the displays and observe the 59313A Channel 1, 2, and 3 outputs. The values should vary approximately as shown.

To check 8709A Option H17 Synchronizer adjustment, turn on 8709A and 8447C power, set 8709A rear panel switch to 6 MHz/Volt, and remove BNC connection from 8709A rear panel INPUT connection. The 8709A front panel meter indication should be centered. If not, use front panel METER ADJUST to center indicator on dial. Reconnect BNC cable to INPUT.

To verify operation of the Source Phase-lock Subsystem, set the 8410B Option H17 NORMAL/ ϕ LOCK switch to ϕ LOCK and run the A/D calibration program. With the 3335A set to 70 MHz at +13 dBm, tune the 8620C to a CW frequency at which source phase-lock is indicated by a steady dot and the 8709A Option H17 UNLOCKED light is out. The 59313A Channel 4 output should be -1024. As the 8620C frequency is changed, phase-lock should be maintained over an approximate ± 10 MHz range. When the UNLOCKED indicator illuminates, 59313A channel 4 should read less than -1024.

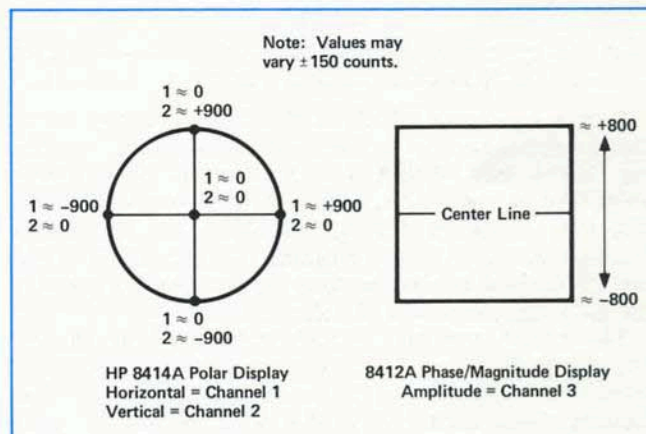
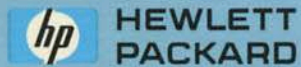

Figure 16. A/D Converter Output vs. Trace Screen Position.



For more information, call your local HP Sales Office or nearest Regional Office: **Eastern** (201) 265-5000; **Midwestern** (312) 255-9800; **Southern** (404) 955-1500; **Western** (213) 970-7500; **Canadian** (416) 678-9430. Ask the operator for instrument sales. Or write Hewlett-Packard, 1501 Page Mill Road, Palo Alto, CA 94304. **In Europe:** Hewlett-Packard S.A., 7, rue du Bois-du-Lan, P.O. Box, CH 1217 Meyrin 2, Geneva, Switzerland. **In Japan:** Yokogawa-Hewlett-Packard Ltd., 29-21, Takaide-Higashi 3-chome, Suginami-ku, Tokyo 168.