

Semi-Automatic Measurements Using the 8410B Microwave Network Analyzer and the 9825A Desk-Top Computer



This application note describes the configuration of a semi-automatic network analyzer using the Hewlett-Packard Interface Bus (HP-IB).

- A block diagram of suggested instruments is reviewed.
- Methods of digitizing 8410B magnitude and phase readings are compared.
- Sources of error in microwave measurements are discussed.
- The fundamentals of one-port vector error-correction are introduced.
- A sample program for the HP 9825A desk-top computer providing for calibration and measurement is listed along with annotations and flow charts.
- Typical data from this program are presented as well as operating procedures and discussion about the standards employed in calibration.

This note contains operating and programming information for the HP 11863A Applications Pac. The Pac is a tape cartridge containing the program listed on pages 13—16.

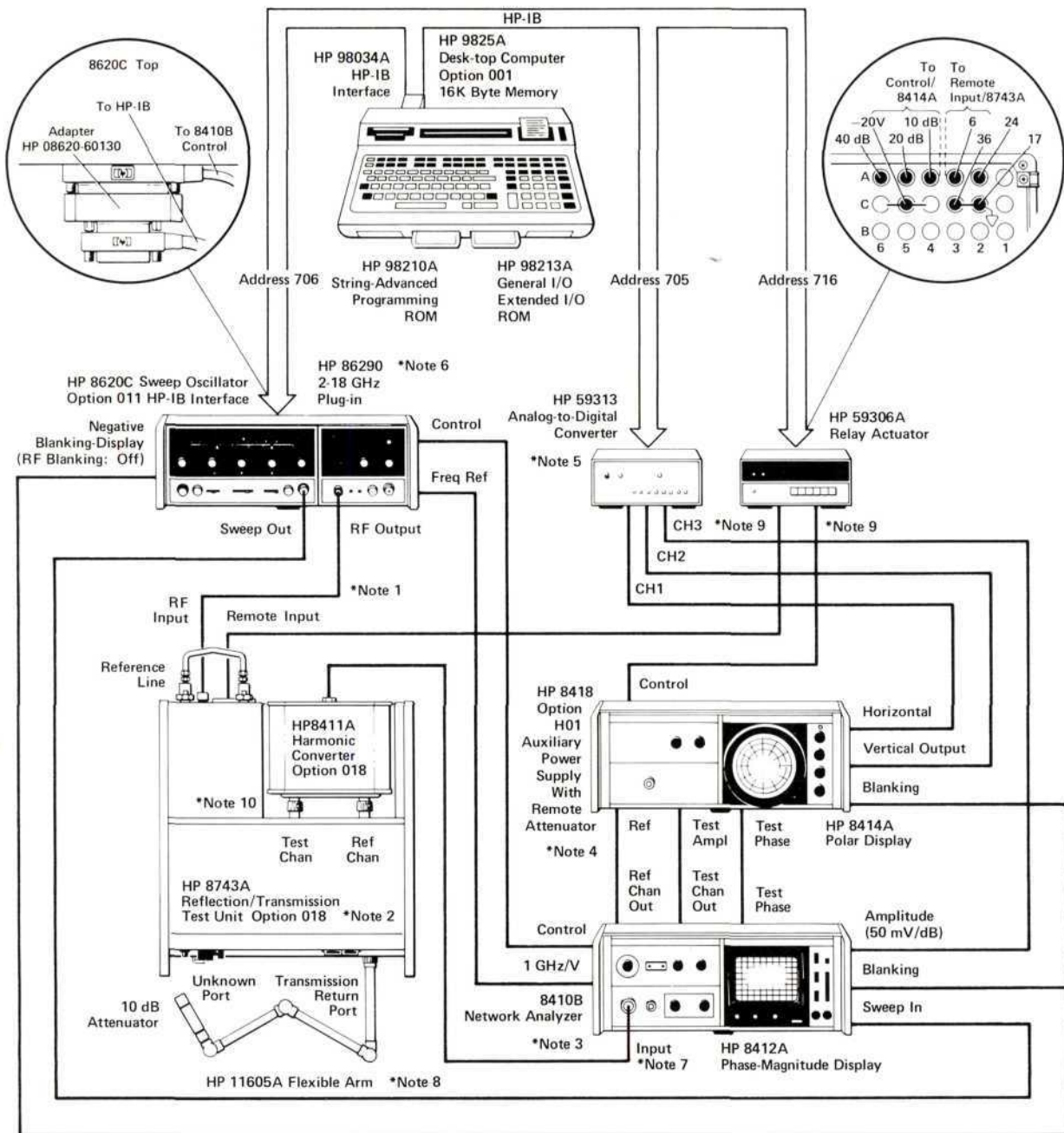

NOTES

- 1 To maximize performance in 12–18 GHz, the shortest low-loss RF line of either .141 semi-rigid or Amphenol-plex or Flexco foam dielectric cable is suggested.
- 2 The HP 8746A Test Set can be used for full two port measurement in the .5 – 12.4 GHz range. Likewise, the HP 8745A Test Set can be substituted in the .1 – 2 GHz range.
- 3 The HP 8410A can be used in single octave applications (manually setting the frequency range).
- 4 If manually setting IF Gain is not objectionable, the HP 8414A can be used mounted in the HP 8410 mainframe and the HP 8418A Option H01 can be eliminated
- 5 Setup Channels 1 and 2 for 2.5 volts full scale, Channel 3 for 5 volts full scale.
- 6 Other HP 8620 Plug-ins are suitable for narrower frequency range applications.
- 7 HP 8410B Option C06 provides IF Connector on the rear panel for rack mount applications.
- 8 For longer test devices, a .141 semi-rigid return cable (08542-60121) may be employed.
- 9 Cables supplied with HP 8418A Option H01.
- 10 Appropriate attenuators may be used in test and reference channels to extend dynamic range. See pages 3-6 and 3-7 of HP Application Note 117-1.

Figure 1. Block Diagram – 2-18 GHz Semi-Automatic Network Analyzer

WHAT CAN IT DO?

Basically the configuration described can provide economical automated reflection-transmission measurements of microwave components without compromising normal swept operations or requiring specially modified instruments.

The synergism of a network analyzer and a fast computing controller allows the rapid characterization of various RF system errors using known calibration standards and subsequent error-corrections during measurement of unknown devices.

While one expects such a system to be worthwhile in large quantity production situations, the versatility and convenience also makes it a cost effective tool in small volume production and laboratory applications.

EQUIPMENT SUGGESTED

Network Analyzer	HP 8410B/8411A
Polar Display	HP 8414A
Phase-Magnitude Display	HP 8412A
Auxiliary Power Supply (with Remote Attenuator and Special Interface Cables)	HP 8418A Opt H01
Relay Actuator	HP 59306A
Analog-to-Digital Converter	HP 59313A
Test Set	HP 8743A or HP 8746A or HP 8745A
Sweep Oscillator Mainframe (with HP-IB Programming Option)	HP 8620C Opt. 011
2-18 GHz Sweep Oscillator RF Plug-in	HP 86290
Desktop Computer with 16K Byte Memory	HP 9825A Opt. 001
String-Advanced Programming ROM	HP 98210A
General I/O - Extended I/O ROM	HP 98213A
HP-IB Interface	HP 98034A
Application Pac - program on tape cartridge	HP 11863A
1 ft. BNC cables (4 each)	HP 11170A
4 ft. BNC cables (3 each)	HP 11170C
1m HP-IB Cable (2 each)	HP 10631A
4 ft. Low Loss RF Cable N Male Connectors	Amphenol-Amplex or Equivalent

Calibration Components — See Table 1 on Page 9. Chose those appropriate to the connector types and frequency ranges of devices to be tested.

SYSTEM BLOCK DIAGRAM

A block diagram of a semi-automatic system is shown in Figure 1. This setup automates a wideband 2-18 GHz network analyzer configuration. The

stimulus uses a HP 8620C Option 011 mainframe programmed via the Hewlett-Packard Interface Bus. The RF Plug-in employed for this frequency range is the HP 86290. Frequencies are programmed in the CW mode. Frequency resolution is fixed by the source's ability to program up to 10,000 points in any band. Since the HP 86290 oscillator may be switched into three individual sub-bands as well as the full range, programming within the sub-bands (2-6.1 GHz, 6.1-12.2 GHz, 12.2-18 GHz) provides the best resolution (400-600 kHz minimum step). Typical frequency accuracy is better than ± 10 MHz. However, this may be improved to the level of the resolution by using a frequency counter connected to the RF Plug-in AUX OUT to monitor actual frequency and make appropriate corrections. See application note 187-5, "Calculator Control of the 8620C Sweep Oscillator using the Hewlett-Packard Interface Bus" for a complete description of this technique and more details on programming the sweeper.

The signal source drives the HP 8743A Reflection/Transmission Test Unit which provides a coupler to sample an incident reference signal as well as couplers and switches to separate reflected and transmitted signals from the device under test.

The HP 8410B incorporates automatic frequency range tuning which allows continuous multi-octave measurements when properly connected to the HP 8620C Sweeper with HP 86290 or HP 86222 (10-2400 MHz) RF Plug-ins. The HP 8410B mainframe houses a HP 8412A Phase/Magnitude Display plug-in in this setup. Three IF signals are coupled from the HP 8410 mainframe into the HP 8418A Option H01 Auxiliary Power Supply. The HP 8418 houses the HP 8414A polar display. Option H01 adds a programmable IF attenuator to the HP 8418 which controls the test channel IF signal level. The analog polar x and y outputs of the HP 8414A are fed to two channels of the HP 59313A HP-IB Analog-to-Digital Converter. A third channel monitors the 50 mV/dB magnitude output from the HP 8412A. The use of phase information from the polar display and magnitude data from the rectangular display provides the best data accuracy and complete display flexibility for manual operation.

In automatic mode, the bus-compatible HP 59306A Relay Actuator programs both the IF attenuator (40, 20, 10 dB steps) with 3 bits and the HP 8743A Reflection/Transmission Test Unit with 2 bits. The versatility and speed of the HP 9825A computer makes it an ideal HP-IB controller.

Other Frequency Ranges

For 100-2000 MHz operation, simply substitute the HP 86222 Oscillator Plug-in for the HP 86290 and the HP 8745A S-Parameter Test Set for the 8743A. In

narrower band applications, you can choose an appropriate octave-band sweep plug-in. For transistor or two port measurement from 500 MHz to 12.4 GHz, a HP 8746A Test Set should be used in place of the 8743A. No changes to the HP 11863A program are necessary with different test sets; RF Plug-in changes require modification of lines 14-15.

WHY DIGITIZE THE POLAR DISPLAY

Since magnitude and phase are the quantities desired, at first glance it seems logical to simply digitize the HP 8412A Phase-Magnitude Display's 10 mV/deg and 50 mV/dB rear outputs. The magnitude detector has an 80 dB range so no adjustments to IF gain on the HP 8410B are required for automatic operation. No computations are necessary to convert from polar to rectangular formats. This works well, for simple magnitude measurement, but there can be problems with phase measurement. The major problem occurs when a measurement happens to fall in the transition as the phase detector switches between $+180^\circ$ to -180° . It is possible to get a false data point as shown in Figure 2. There is no way to differentiate between a real reading of 72° and this false reading with a single measurement.

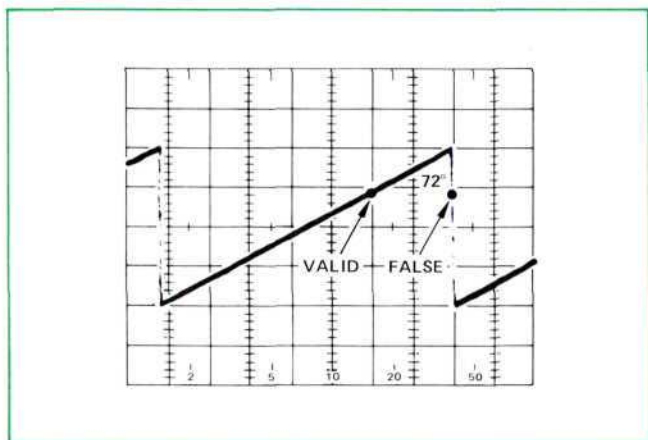

Figure 2. Phase Data is Not Valid if Readings are Taken Within the Transition from $+180^\circ$ to -180° .

The solution — use a polar (synchronous) detector, the HP 8414A:

Polar Output:

$$\text{Horizontal: } X = M \cos\phi$$

$$\text{Vertical: } Y = M \sin\phi$$

After Calculation:

$$\text{Phase: } \phi = \tan^{-1} \frac{Y}{X}$$

$$\text{Magnitude: } M = \frac{Y}{\sin\phi}$$

There is no transition uncertainty with this approach. Also, it is possible to effectively average a noisy polar output. Averaging the phase signal is not useful on a noisy phase output from the 8412A.

However, the polar display is linear not logarithmic, so it is necessary to switch the IF attenuator when the signal level varies over 10 dB. This can be done manually with appropriate prompting from the controller, but it is time-consuming and requires operator interaction on devices with widely varying frequency response. The automatic solution suggested encompasses a FET-switched IF attenuator with 40, 20, and 10 dB sections. When the signal is offscale on the polar display, the program ranges appropriately.

Due to test-to-reference channel leakage within the HP 8414A, the magnitude data varies as a function of phase position by as much as ± 0.25 dB. This is called "quadrature" error. Thus the suggested configuration takes its magnitude readings from the HP 8412A rectangular display to improve accuracy (especially important for low loss and high reflection measurements).

SOURCES OF MEASUREMENT ERROR AT MICROWAVE FREQUENCIES

Network Analysis measurement errors can be separated into two categories:

- **Instrument Errors** (exclusive of test set) are measurement variations due to noise, imperfect conversions, crosstalk, inaccurate logarithmic conversion, non-linearity in displays, drift, etc.
- **Test Set/Connection Errors** are those errors added by the signal separation couplers, test cables, and connector adapters and their interactions with the device under test.

At most microwave frequencies, the latter category is usually the most significant source of measurement uncertainty. For the purpose of vector accuracy enhancement, these uncertainties are quantified as directivity, source match, and frequency tracking vector error terms.

- **Effective Directivity** — This error is a measure of the inability of a bridge or coupler to absolutely separate incident and reflected waves, (combined with the residual reflection effects of test cables and adapters). Directivity has its most profound effect on low reflection (high return loss) measurements. The HP 8743A Test Set has greater than 30 dB directivity at 12 GHz, but necessary connector adapters or cables often degrade effective directivity below 20 dB.

Here is an example of how directivity can affect your measurement. Measuring a device with an actual 1.13 SWR (24 dB return loss) on a HP 8743A with a SMA adapter (typical 26 dB equivalent directivity) will place the uncorrected return loss answer somewhere between 19 dB and 40 dB (1.24 to 1.02 SWR). Computed vector error correction will typically reduce this return loss uncertainty to ± 1 dB (1.13 \pm .015 SWR).

- **Source Match** — When the test port characteristic impedance is not exactly 50 ohms, multiple reflections can occur causing measurement errors. These errors are particularly a problem when measuring very high or low impedances (large mismatch). The source match looking back at the HP 8743A unknown port is specified at 1.3 SWR at 12 GHz. When measuring a .92 reflection coefficient (e.g., 2 Ω diode) this leads to a potential $\pm .11$ reflection coefficient ($\pm 3\Omega$) error. This can be typically reduced by a factor of 10 by computed vector error correction techniques.
- **Frequency Tracking (Frequency Response)** — The frequency response of the HP 8743A Test Set including the variations of the HP 8411A Converter is typically less than $\pm .5$ dB and $\pm 5^\circ$ from 2 - 12 GHz. These variations can be stored and removed automatically with the program listed in this application note.

The following discussion illustrates how these error terms are determined, and more importantly, how they can be used to increase measurement accuracy.

INTRODUCTION TO ERROR CORRECTIONS

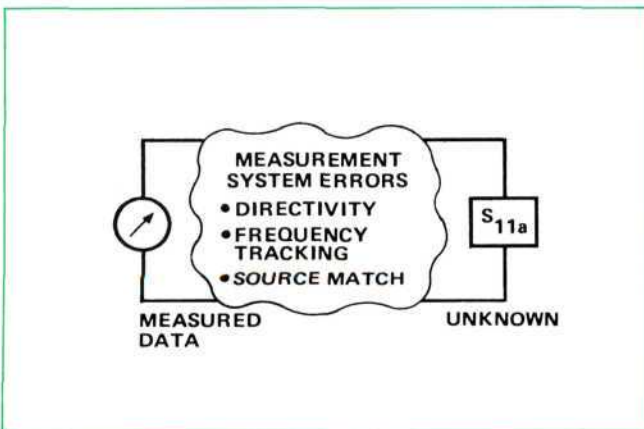

Let's consider measurement of some unknown's reflection coefficient (or return loss). No matter how careful we are, the measured data will differ from the actual. These are the major sources of error.

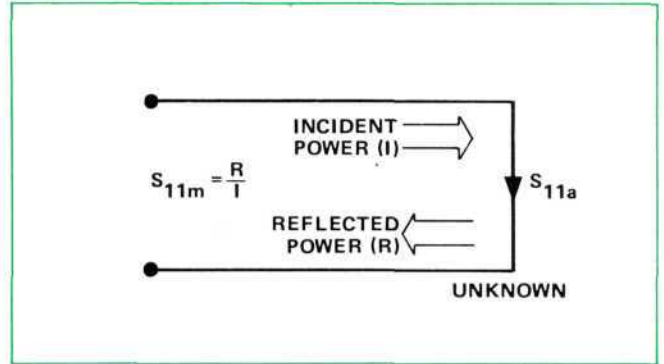

REFLECTION COEFFICIENTS are measured by first separating the incident power (I) from the reflected power (R) and then taking the ratio of the two values.

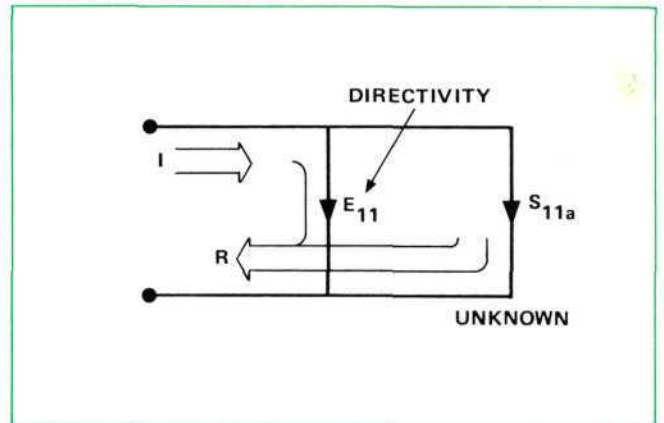

Unfortunately, all of the incident power doesn't always reach the unknown. Some of (I) may bounce off imperfect adapters. Also, couplers and bridges are never perfect in separating (R) from (I). This error, E_{11} , is DIRECTIVITY.

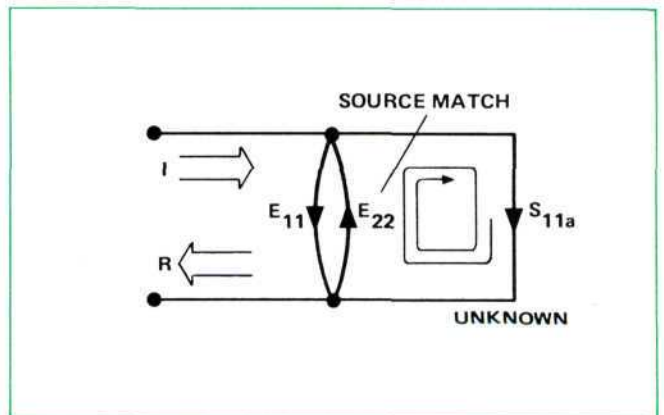

Since the measurement system test port is never exactly the characteristic impedance (normally 50 ohms), some of the reflected signal bounces off the test port and back to the unknown, adding to the original incident signal (I). This re-reflection effect is called SOURCE MATCH error, E_{22} .

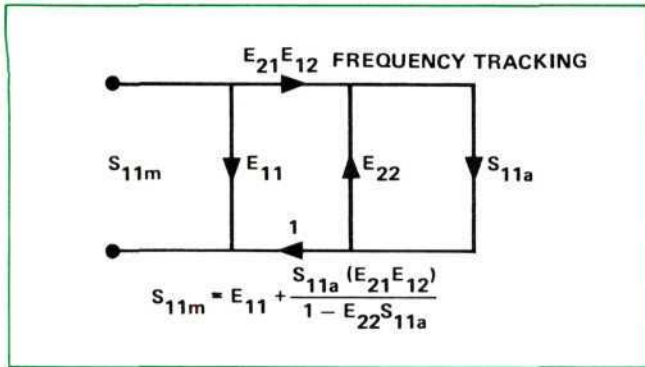

FREQUENCY TRACKING error, $E_{21}E_{12}$, is caused by small variations in gain and phase flatness vs. frequency (frequency response error) between the test and reference channel signals due to imperfectly matched cables, differences between incident and test couplers and in the converter, etc. It can be shown that these three errors are mathematically related to the actual (S_{11a}) and measured data (S_{11m}).

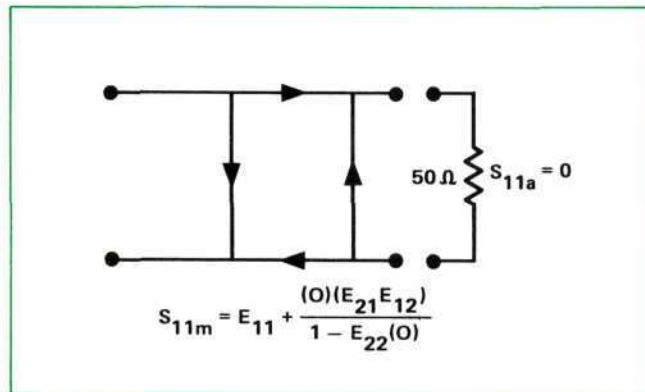

If we knew the three "E" errors at each frequency we could remove them mathematically from our measured data. They are found by measuring (calibrating) with three independent standards whose S_{11a} is known at all frequencies.

First standard applied is a "perfect" LOAD which makes $S_{11a} = 0$ and essentially measures directivity (E_{11}) directly.

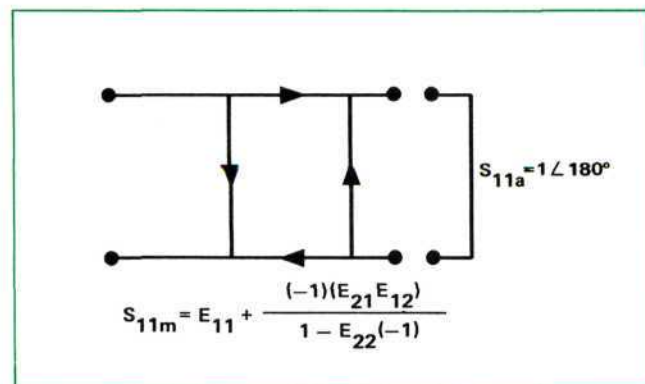

Then a SHORT circuit termination is used for the first condition of a two equation, two unknown solutions to determine E_{22} and $E_{21}E_{12}$.

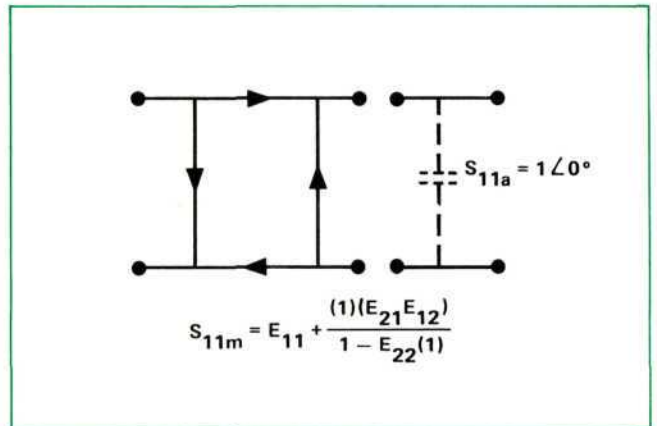

The OPEN gives us the second condition. The program can compensate for the residual fringing capacitance at the open connector.

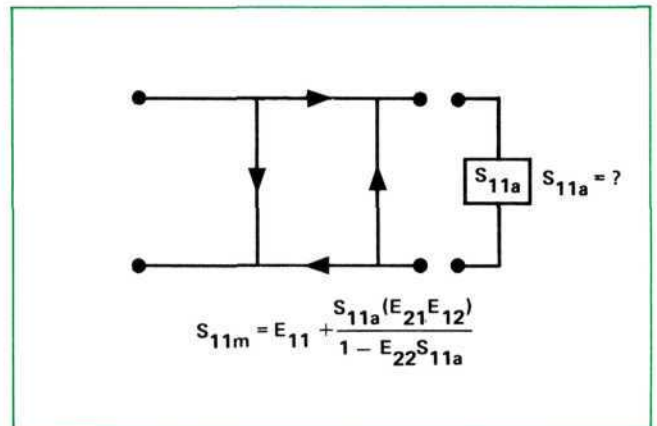

We now MEASURE the unknown S_{11a} and store the measured data S_{11m} at each frequency.

$$S_{11a} = \frac{S_{11m} - E_{11}}{E_{22} (S_{11m} - E_{11}) E_{21} E_{12}}$$

This is what the above equation looks like when solved for S_{11a} . Since we have the three errors and S_{11m} for the unknown stored at each frequency, we can CALCULATE S_{11a} .

Input Reflection Coefficient (S_{11}):

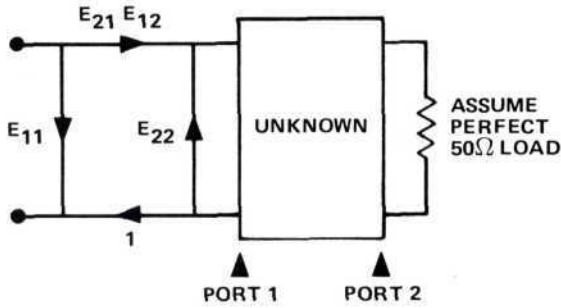

Output Reflection Coefficient (S_{22}):

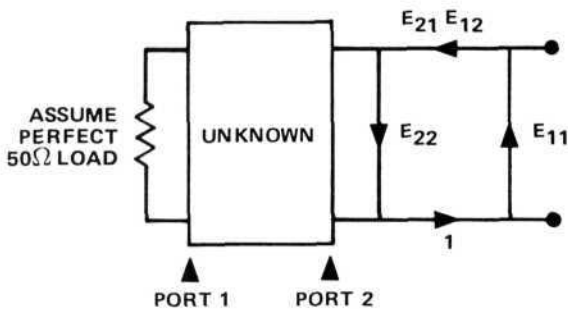

Forward Transmission (S_{21}):

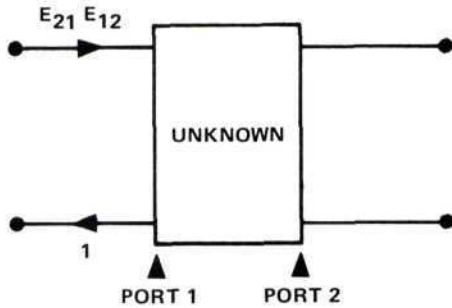

Reverse Transmission (S_{12}):

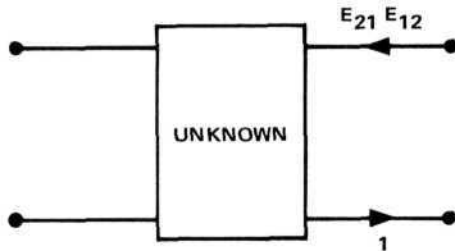

HP 11863A ERROR MODEL

A flow graph representation of the error-model used in the HP 11863A Pac is shown on this page. The model removes the effects of effective directivity, source match, and frequency tracking for reflection measurements and frequency tracking for transmission measurements.

The HP 8743A Reflection/Transmission Test Set requires that two-port test devices be disconnected, turned 180 degrees, and then reconnected to measure all four S-Parameters. Therefore, only the models for S_{11} and S_{21} apply to that test set. The program will automatically switch the HP 8745A and HP 8746B S-Parameter test sets for measurement and correction of all four S-Parameters according to the above models.

OTHER ERROR MODELS

Other error models can be developed which include the effects of reference to test channel isolation and transmission mismatch uncertainty. These models can vary considerably according to the test set used. The introduction of additional terms makes a model more accurate at the expense of considerable mathematical complexity and calculation time.

Possibly one of the most serious limitations of the HP 11863A Pac model is the absence of correction for transmission mismatch uncertainty, particularly with low loss two-port devices such as short cables. However, use of matching fixed attenuators can substantially minimize this error.

It is chiefly in the characterization of devices like transistors and FETs that this compromise is less effective than the more complete error models that have been used previously in more elaborate computer based systems. For example, mismatch errors can effect the 6 dB gain measurement of a transistor at 3 GHz by as much as ± 1.5 dB. However, the HP 11863A error model can also reduce S_{11} and S_{22} reflection coefficient uncertainty on this transistor from $.6 \pm .1$ to $.6 \pm .01$ at 3 GHz.

In most other applications areas, the most profound contribution of the more sophisticated models has been in the enhancement of reflection measurement accuracies. In this area the HP 11863A model is almost as effective.

HARMONIC PHASE-LOCK ERROR

There is a potential error contributor in automatic applications that may not be as apparent to the manual network analyzer user. The phase-lock circuitry of the HP 8410 essentially tunes the frequency of a 65-150 MHz oscillator in the HP 8411A until some harmonic of this oscillator beats in a mixer (sampler) with the unknown reference input microwave signal to produce a 20.278 MHz IF. For example, at 5 GHz we might lock using the 40th harmonic of approximately 125 MHz or the 50th harmonic of approximately 100 MHz. The sampler conversion characteristics may vary by .25 dB and 2° between these harmonic numbers. So if calibration occurs with one harmonic number and measurement of a device under test with another, this difference can occur.

PROGRAM OPERATION

- 1 Set up measurements manually.
 - Insert device under test and sweep the band of interest. (If instruments are in **Remote**, perform step 2 to set all to **Local** mode. Test set is controlled by manual operation of relays 2 and 3.)
 - Use appropriate adapters and test cables (their characteristics will be included in the calibration).
 - Set up test power level (use highest level allowable by the device under test and oscillator plug-in, but within the HP 8410B reference level meter range. This is particularly important above 12 GHz).
 - Set 8410B Frequency Range to **AUTO**.
 - Adjust sweep stability for a clean display presentation.
- 2 Insert Applications Pac cartridge, rewind, load file 0, press **RUN**. "START FREQ (MHz)?" will appear in the display. Type the desired first test frequency and press **CONTINUE**.
- 3 "STOP FREQ (MHz)?" will then appear. Type the desired last test frequency and press **CONTINUE**.
- 4 "FREQ STEP (MHz)?" will then appear. Type the desired increment between test points and press **CONTINUE**.

NOTE

This program is limited to 40 frequency points with a 16K byte calculator. If more than 40 points are chosen, the program automatically jumps back to "START FREQ (MHz)?" (step 2). Also if a frequency step is chosen that divides the span into a non-integer number of test frequencies, the last frequency will NOT be the stop frequency. It will be the highest frequency less than the stop frequency with an integer number of steps.

e.g. If Start Freq = 2000 MHz
and Stop Freq = 3000 MHz
and Freq Step = 333 MHz

Test frequencies will be 2000, 2333, 2666, and 2999 MHz.

- 5 "WHAT S (11, 21, 12, 22) - CON'T TO END?" requests the entry of which S Parameters you want to measure. Remember S₁₁ corresponds to input reflection
 - S₂₂ output reflection
 - S₂₁ forward transmission
 - S₁₂ reverse transmission

Enter the digits corresponding to your choices in the sequence you wish to output data followed by **CONTINUE**'s. You may enter up to 4 sets.

e.g. If you wish to measure and print S₁₁, S₂₂ and S₂₁ in that sequence enter 11 **CONTINUE** 22 **CONTINUE** 21 **CONTINUE** and a final **CONTINUE** to end the entry sequence.

Do not request S₁₂ or S₂₂ when using the HP 8743A test set with the standard program.

- 6 "SET TEST CHANNEL GAIN TO 60 DB" reminds you to make that setting so the calculator will have a known starting point when setting the IF attenuator. The operation of this configuration is described as "semi-automatic" because it requires one to initially switch some controls (Freq Range, IF gain) and abstain from making further adjustments once the calibration sequence is begun.
- 7 As the first step in the calibration sequence, the program sorts through the requested S parameters.
 - If S₁₁ was chosen,
 - "PORT 1 — CONN LOAD" appears
 - Press **CONTINUE**
 - "SLIDING TYPE (Y/N)?"

Asks what type of standard load you intend to calibrate with.

If you are operating below 2 GHz, use of a sliding load is normally not possible due to the limited length of slide and the characteristics of the sliding element. At these lower frequencies a standard fixed termination (see Table 1 below) can be used by answering N CONTINUE after connecting the standard. The system then measures the load at all test frequencies.

If a sliding load is available and appropriate for the frequency range, answer Y CONTINUE after attaching. The system then measures the load at all test frequencies. For a total of five additional load positions "SLIDE" is requested. After moving the load to a new position, press CONTINUE. The system again measures at all frequencies. At the last position the system computes the center of the circle. For best results in 2 — 18 GHz operation, slide the load in a 2, 1, 2, 1, 1 division sequence. Each division is 1/4 inch. Start at the end closest to the test set.

- 8 "PORT 1 - CONN SHORT" is then displayed. Connect an appropriate short circuit termination (Table 1) and press CONTINUE.
- 9 After the system measures again at all test frequencies, "PORT 1 - OPEN" is displayed. With most connector types, an open circuit can be modeled effectively as an open with a shunt capacitance. The listed program uses an open capacitance value of 0.081 pf for the APC-7 connector. If you use other connector types, modify the value for K (3) in line 6 in accordance with Table 1. For operation above 14 GHz, it may be necessary to use a shielded open (see Table 1) to prevent radiation.

Open the circuit at Port 1 (or attach shielded open) and press CONTINUE. Once again the system measures at all frequencies.

- 10 The program again sorts through the requested S parameters to determine if S_{22} was chosen. If this is the case "PORT 2 - CONN LOAD" appears. Repeat steps 7 through 9 for the other test port on the 8745A or 8746A test sets.
- 11 Again, the program sorts through the requested S parameters looking first for S_{21} then S_{12} . If either is found, it switches the test set appropriately and commands "CONN THRU".

Connect Port 1 and 2 together and press CONTINUE. The system measures through the test frequencies once to characterize tracking, then in the case of S_{21} sorts for S_{12} . If found, it switches and measures tracking in the other direction.

NOTE

It might be necessary to switch the sex of precision connector adapters to achieve a through connection. Switching between high quality equal electrical length adapters is preferable to the use of a male-male or a female-female adapter to allow a connection.

- 12 Now the actual measurement of a device under test begins with the display "CONN DEVICE, ENTER LABEL?". If you wish to label your data, type your label (serial number) up to 16 alphanumeric characters and press CONTINUE. For unlabeled data, press SPACE BAR CONTINUE. The system sets up and measures and corrects the S parameters in the order selected.

Connector ¹ Type	Sliding Load	Fixed ² Load	Short	Calibration Kit ^{2,3}	Shielded Open Circuit	Open Capacitance pf
APC-7	905A	H68-909A	11565A	—	11637-60002	.081
N-Male	905A	H69-909A	11512A	85032A	11638-60002	.032
N-Female	905A	H70-909A	11511A	85032A	11638-60018	-.180
SMA-Male	911A	0960-0053	0960-0055	85033A	11639-60002	-.064
SMA-Female	911A	0960-0050	0960-0054	85033A	11639-60018	.032

¹ Calibration standards for other coaxial connector types such as TNC and various waveguide sizes are available from Maury Microwave, Cucamonga, California and Alford Manufacturing, Winchester, Massachusetts

² Selected for low reflection below 2 GHz.

³ These kits include two (2) each APC-7 Adapters for each sex and both fixed loads and shorts in wooden box.

Table 1. Calibration Standards

- 13 After all measurements are complete, output data is printed on the strip printer again in the S parameter sequence requested. Since all data is taken prior to any output, the device just tested can be removed and the next one inserted during the printing of data. Then, the program cycles back the "CONN DEVICE, ENTER LABEL" again.

MEASUREMENT RESULTS

An example of the accuracy improvement available is shown in Figure 3. Here a 10 cm APC-7 air line is added at the unknown port and uncorrected reflection data is taken on a good termination over the 6-12 GHz band. The data ripple is largely due to the phasing interaction of the directivity error vector with the device under test. The corrected data plotted after calibration at the end of the 10 cm air line represents an obvious improvement in accuracy.

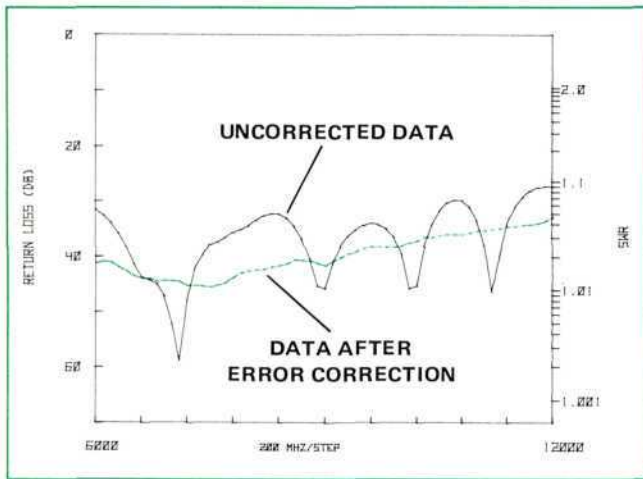

Figure 3. Return Loss Data on a good Termination Before and After Vector Error Correction.

Printouts are also provided comparing data taken with this configuration with standards lab data measured with a HP 8542B. Devices tested include a 10 cm air line, 10 dB attenuator, .3 standard mismatch, and an offset short circuit.

PROGRAMMING CONSIDERATIONS

The program is available recorded on a cartridge as the HP 11863A Applications Pac. It is divided into five main sections:

- | | |
|---------------------------------|---------|
| | Lines |
| • Initialization and Freq Entry | 0—30 |
| • Calibration | 31—89 |
| • Measurement | 90—118 |
| • Subroutines | |
| Main Measurement Loop | 119—135 |

- | | |
|------------------------------|---------|
| Set Frequency on 8620C/86290 | 136—141 |
| Read 8410 | 142—164 |
| Polar to rectangular | 165—168 |
| Rectangular to polar | 169—175 |
| Complex multiply | 176—179 |
| Complex divide | 180—184 |
| Find center of circle | 185—208 |
| • Printed Data Output | 209—226 |

The corrected values of the four S-Parameters are stored in two arrays:

$$X(M,N) = \text{real part}$$

$$Y(M,N) = \text{imaginary part}$$

The first array index, M, ranges from 1 to 4 and identifies each S-Parameter.

M	S-Parameter
1	S_{11}
2	S_{21}
3	S_{12}
4	S_{22}

The second array index, N, ranges from 1 to F (4) where F (4) is the total number of test frequencies. For example, corrected data for S_{21} at the third frequency point would be stored in X (2,3) and Y (2,3).

During calibration with the load, short, open, and thru, the values of eight complex error coefficients are calculated and stored in a third array E (M,N) where N is defined above and M ranges from 1 to 16 and identifies the real or imaginary part of each error coefficient.

M (Error Coefficient Index)		Error Coefficient Description
Real Part	Imaginary Part	
1	2	Port 1 Directivity
3	4	Port 1 Source Match
5	6	Port 1 Reflection Tracking
7	8	Port 2 Directivity
9	10	Port 2 Source Match
11	12	Port 2 Reflection Tracking
13	14	Forward Transmission Tracking
15	16	Reverse Transmission Tracking

Manual Operation of IF Attenuator

If the Option H01 programmable attenuator for the HP 8418A is not available initially, the following modification will allow manual control of the 8410B gain control.

```
29: dsp "SET TEST CHANNEL GAIN TO 10 DB";stp
158: "ATTEN";dsp "SET GAIN TO",10(7-0);stp
```

MEASUREMENT DATA COMPARISON

10 dB ATTENUATOR

Freq—MHz	Standards Data		Sample Data	
	Loss—dB	Phase	Loss—dB	Phase
	Forward	Forward	Forward	Forward
2000	10.16	179.5	10.2	179
3000	10.17	89.1	10.1	91
4000	10.18	.2	10.1	1
5000	10.13	-89.0	10.2	-89
6000	10.11	-179.1	10.1	-176
7000	10.08	90.3	10.1	94
8000	10.09	-.5	10.1	-0
9000	10.05	-91.2	10.1	-93
10000	10.01	177.0	10.1	174
11000	10.03	85.0	10.0	80
13000	9.96	-100.4	9.9	-101
14000	9.93	165.7	10.0	164
15000	9.84	71.1	9.9	70
16000	9.88	-24.5	10.0	-25
17000	9.85	-120.7	9.9	-119
18000	9.86	141.9	9.9	141

0.3 MISMATCH

Freq—MHz	Standards Data		Sample Data	
	Return	Return	Return	Return
	Loss—dB	Refl—Ang	Loss—dB	Refl—Ang
2000	8.8	-137.93	8.9	139
3000	8.85	153.05	8.7	152
4000	8.85	84.72	8.7	84
5000	8.87	16.16	8.7	16
6000	8.95	-52.62	9.0	-51
7000	9.02	-122.22	9.1	-123
8000	9.02	168.73	8.9	168
9000	8.92	100.47	8.7	100
10000	9.09	33.85	8.7	33
11000	9.27	-33.75	9.1	-31
13000	9.95	-172.34	9.8	-174
14000	10.09	117.00	9.9	118
15000	10.2	47.46	9.9	48
16000	10.4	-20.68	10.2	-17
17000	10.87	-88.80	10.7	-84
18000	11.6	-157.68	11.6	-157

10 CM AIRLINE

Freq—MHz	Standards Data		Sample Data	
	Loss—dB	Phase	Loss—dB	Phase
	Forward	Forward	Forward	Forward
2000	.09	114.1	0.1	114
3000	.10	-8.4	0.1	-8
4000	.10	-131.0	0.0	-127
5000	.06	106.8	0.1	105
6000	.05	-15.8	0.0	-16
7000	.03	-138.4	0.1	-139
8000	.04	98.9	0.1	102
9000	.04	-23.5	0.1	-27
10000	.02	-146.3	0.2	-151
11000	.08	91.0	0.2	85
13000	.12	-154.1	0.1	-157
14000	.11	82.8	0.2	82
15000	.11	-39.7	0.0	-39
16000	.08	-162.3	0.0	-164
17000	.09	75.1	0.0	74
18000	.11	-47.7	0.1	-48

OFFSET SHORT

Freq—MHz	Standards Data		Sample Data	
	Return	Return	Return	Return
	Loss—dB	Refl—Ang	Loss—dB	Refl—Ang
2000	.10	119.72	0.3	121
3000	.11	89.52	0.4	90
4000	.13	59.62	0.4	59
5000	-.01	30.10	0.3	29
6000	.00	.07	0.2	-1
7000	.01	-29.99	0.0	-29
8000	-.01	-59.86	-0.2	-59
9000	-.01	-89.82	-0.3	-90
10000	-.03	-120.57	-0.2	-121
11000	.02	-150.15	-0.1	-151
13000	.03	150.03	0.1	151
14000	.04	120.07	0.2	122
15000	.06	90.20	0.1	92
16000	.03	60.50	0.1	62
17000	.06	30.84	0.0	33
18000	.07	.94	-0.3	6

SIMPLIFIED PROGRAM FLOW CHART

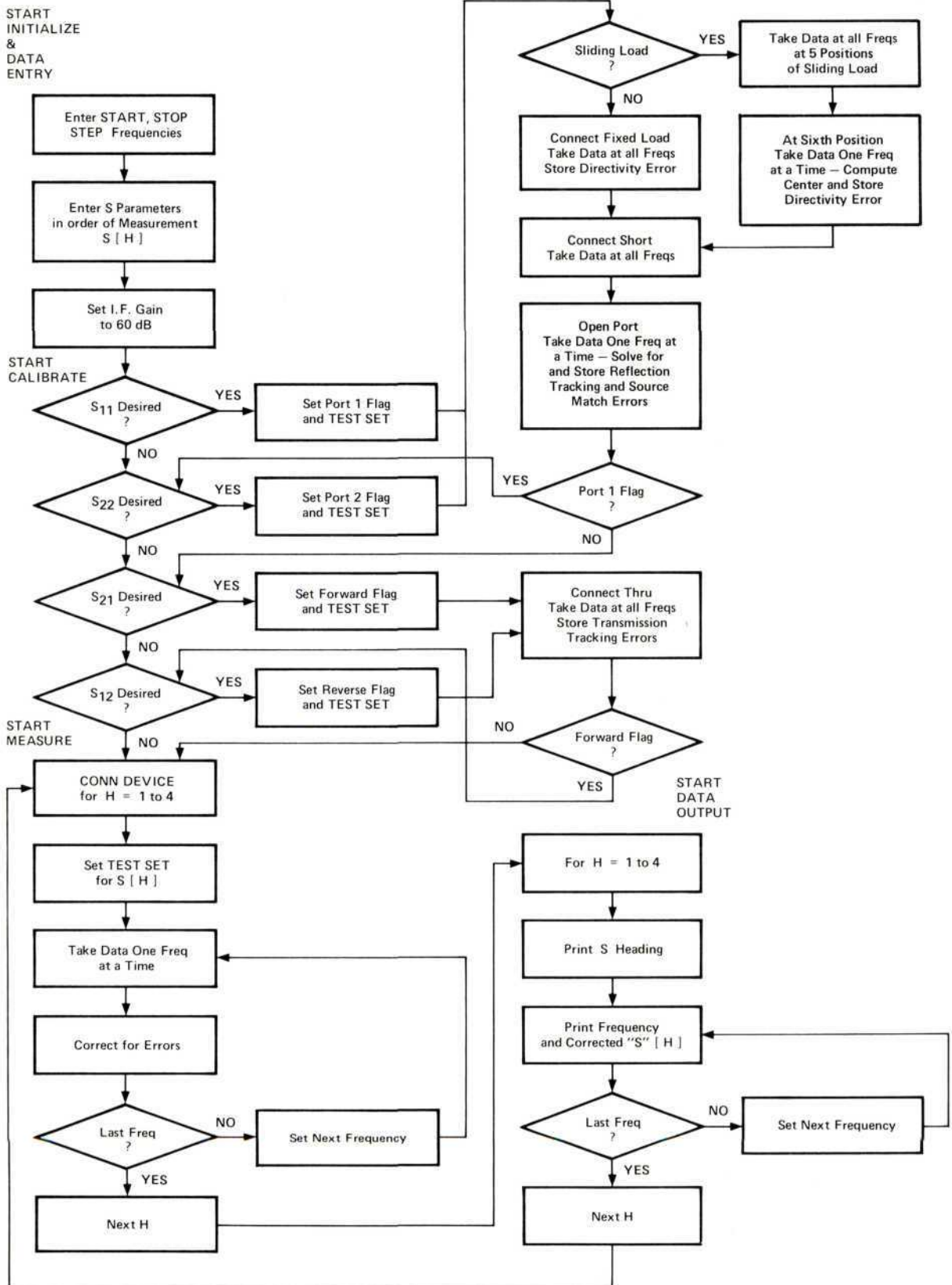

ANNOTATED LISTING 11863A APPLICATION PAC

```

0: "8410 SEMI-AUTOMATIC NETWORK ANALYZER PROGRAM":
1:
2: "INITIALIZATION AND FREQ ENTRY*****":
3:
4: dia X[4,40],Y[4,40],X#[16],Q#[6,5],T#[4,4],P#[4],S#[4,3]
5: dia E[18,40],F[6],T[16],K[5],A[6],B[6],S[4],E#[7]
6: 50+K[4]; 081+K[3] ..... Define Impedance and Open Circuit Capacitance
7: "S11"+S#[1,1]; "S21"+S#[2,1] ..... Define Printer Titles
8: "S12"+S#[3,1]; "S22"+S#[4,1] ..... Define Printer Titles
9: "A46B5"+Q#[6,1]; "A6B45"+Q#[5,1] ..... Define Relay Settings for 50, 40, 30, 20, 10, 0 IF Attenuator Values
10: "A45B6"+Q#[4,1]; "A5B46"+Q#[3,1] ..... Define Relay Settings for 50, 40, 30, 20, 10, 0 IF Attenuator Values
11: "A4B56"+Q#[2,1]; "B456 "+Q#[1,1] ..... Define Relay Settings for 50, 40, 30, 20, 10, 0 IF Attenuator Values
12: "B23"+T#[1,1]; "A2B3"+T#[2,1] ..... Define Relay Settings for S11, S21, S12, S22 Test Set Positions
13: "A3B2"+T#[3,1]; "A23"+T#[4,1] ..... Define Relay Settings for S11, S21, S12, S22 Test Set Positions
14: 2000+r1;6000+r2;12000+r3 ..... Define Start Freqs for All Bands (86290B)
15: 10000/4200+r4;10000/6400+r5;10000/6600+r6 ..... Define Band Spans (86290B)
16: lcl ?;rem ? ..... Go to Local
17: "FREQS?":ent "START FREQ (MHZ)",F[1]
18: ent "STOP FREQ (MHZ)",F[2]
19: ent "FREQ STEP (MHZ)",F[3]
20: int((F[2]-F[1])/F[3])+1+F[4] ..... Calculate Number of Test Points
21: if F[4]>40;eto "FREQS" ..... Test for <40 Points
22: for H=1 to 4
23: ent "WHAT S(11,21,12,22)-CONT TO END",S[H]
24: if fl=1;eto +5 ..... No Entry ? Jump Out
25: S[H]/10+S[H]
26: int(S[H])>P ..... S11 = 1; S21 = 2; S12 = 3; S22 = 4
27: P+(S[H]-P,.1)2>S[H]
28: next H
29: dsp "SET TEST CHANNEL GAIN TO 60 DB";stp
30: 0+0;6+Q;wrt 716,Q#[6,1] ..... Set IF Attenuator to 50 dB
31:
32: "CALIBRATION SECTION*****":
33:
34: "S11 Cal":
35: 1+U;asb "SORT" ..... If S11, Set Flags and Program Test Set,
36: if U<1;+M;"PORT 1-">E#;wrt 716,T#[1,1];asb "LOAD" then Calibrate Port 1/Reflection
37: "S22 Cal":
38: 4+U;asb "SORT" ..... If S22, Set Flags and Program Test Set,
39: if U<1;+M;"PORT 2-">E#;wrt 716,T#[4,1];asb "LOAD" then Calibrate Port 2/Reflection
40: "S21 Cal":
41: 2+U;asb "SORT" ..... If S21, Set Flags and Program Test Set,
42: if U<1;+M;wrt 716,T#[2,1];asb "THRU" then Calibrate Forward Transmission
43: "S12 Cal":
44: 3+U;asb "SORT" ..... If S12, Set Flag and Program Test Set,
45: if U<1;+M;wrt 716,T#[3,1];wait 50;asb "THRU" then Calibrate Reverse Transmission
46: eto "MERS"
47:
48: "SORT":for H=1 to 4
49: if S[H]=U;-1+U;ret ..... If "S" Selected is Found in Array, Output-1
50: next H
51: ret.
52:
53: "LOAD":1+I;beep;dsp E#,"CONN LOAD";stp ..... Set Loop Pointer to Store Data
54: ent "SLIDING TYPE (Y/N)",P#
55: if cap(P#[1])="Y";eto +4
56: asb "LOOP" ..... Fixed Load Measurement
57: M+2+M ..... Increment Error Coefficient Index for Short
58: eto +9 ..... Jump Around Sliding Load Measurement
59: for H=1 to 6 ..... Measure for 6 Positions (5 Slides) of Load
60: if H=6;2+I ..... Set Loop Pointer for Center of Circle Computation
61: asb "LOOP"
62: if H=6;eto +4
63: dsp "SLIDE";beep;stp
64: M+2+M ..... Increment Error Coefficient Index for Each Slide
65: next H
66: M-8+M;1+I ..... Set Index Back for Short; Loop Pointer to Store Data Again
67: beep
68: dsp E#,"CONN SHORT";stp
69: asb "LOOP"
70: beep
71: M+2+M;3+I ..... Increment Error Coefficient Index for Open; Loop Pointer to Compute Source Match and Reflection Tracking Errors
72: dsp E#,"OPEN";stp
73: asb "LOOP"
74: ret.

```

```

74: ret
75:
76: "THRU":if 0#1#beep#ids# "CONN THRU";sto ..... First Time thru Only
77: 1#1#0#asb "LOOP" ..... Set Loop Pointer to Store Data
78: ret
79:

80: "MATH DURING CALIBRATION":
81: "CALREFL":E[M-4,N]-E[M-2,N]+TE[1] ..... ESOURCE =
82: E[M-3,N]-E[M-1,N]+TE[2] ..... MATCH
83: E[M,N]-E[M-4,N]+TE[3]
84: E[M+1,N]-E[M-3,N]+TE[4]
85: cll 'P/R'(1,2atn(√FC[5]KE[4]KE[3]2e-6),TE[5],TE[6]) - Corrects for
86: cll 'C*(TE[5],TE[6],TE[3],TE[4],TE[7],TE[8]) ..... Capacitance
87: cll 'C*(TE[7]-TE[1],TE[8]-TE[2],TE[3]+TE[1],TE[4]+TE[2],E[M-2,N]+E[M-1,N]) ..... [EOPEN-ESHORT]
88: cll 'C*(1+E[M-2,N],E[M-1,N],TE[1],TE[2],E[M,N],E[M+1,N]) ..... EREFL TRACK =
89: sto "INDEX" ..... [1 + ESOURCE] [ELOAD-ESHORT]
90: ..... MATCH

91: "MEASUREMENT SECTION*****":
92:
93: "MERS":beep
94: ent "CONN DEVICE; ENTER LABEL",X# ..... Provides 16 Character Label
95: for H=1 to 4 ..... Up to Four Measurements
96: SCH#M;if M<1;sto "OUT" ..... Last Measurement - Jump to output Printing
97: wrt 716,T#[M,1];wait 500 ..... Set Test Set
98: 7#1 ..... Set Loop Pointer to Reflection
99: if M=2 or M=3#8#I ..... If S21 or S12, Set Loop Pointer to Transmission
100: esb "LOOP"
101: next H
102: sto "OUT" ..... Jump to Output Printing
103:

104: "MATH DURING MEASUREMENT":
105: "MESREFL":
106: X[M,N]-E[1+(M=4)6,N]+TE[3] ..... A [1], B [1] = [EMEAS - ELOAD] / EREFL-TRACK
107: Y[M,N]-E[2+(M=4)6,N]+TE[4] .....
108: cll 'C*(TE[3],TE[4],E[5+(M=4)6,N],E[6+(M=4)6,N],A[1],B[1])
109: cll 'C*(A[1],B[1],E[3+(M=4)6,N],E[4+(M=4)6,N],TE[3],TE[4])
110: 1+TE[3]+A[3] ..... A [3], B [3] = 1 + (A [1], B [1]) (ESOURCE MATCH)
111: TE[4]+B[3]
112: cll 'C*(A[1],B[1],A[3],B[3],X[M,N],Y[M,N]) ..... CORRECTED DATA (X,Y) = A [1], B [1] / A [3], B [3]
113: sto "INDEX"
114:
115: "MESTRAN":13+2(M=3)+TE[1]
116: cll 'C*(X[M,N],Y[M,N],E[TE[1],N],E[TE[1]+1,N],TE[2],TE[3]) ..... CORRECTED DATA (X,Y) =
117: TE[2]+X[M,N]+TE[3]+Y[M,N] ..... MEASURED / TRANS. TRACK
118: sto "INDEX"
119:

120: "SUBROUTINES SECTION*****":
121:
122: "MAIN MEASUREMENT LOOP":
123: "LOOP":1#N;FC[1]+FC[5] ..... Initialize Frequency Index and Transfer Start Freq to Current Freq Register
124: "NEXT":esb "FREQ"
125: if N#1;sto +2
126: wait 1500 ..... First Point Waits 1.5 Second Additional
127: esb "READ"
128: if I=2;sto "CCENT"
129: if I=3;sto "CALREFL" ..... Branch to Intermediate Calculations before Taking Data at the Next Frequency
130: if I=7;sto "MESREFL"
131: if I=8;sto "MESTRAN"
132: "INDEX":if N=FC[4];sto +3
133: N+1#N;FC[5]+FC[3]+FC[5] ..... Increment Index and Frequency
134: sto "NEXT"
135: ret

```

```

136:
137: "SET FREQUENCY ON 86200-86250":
138: "FREQ":(F[5]>6100)+(F[5]>12200)+1*R ..... Calculate Band Number from F Desired
139: (F[5]-R)*R+(3+R)*F[6] ..... Voltage = (FDESIRED - FSTART) / Band Span
140: fnt 1,"M1B",f.0,"V",f4,0,"E"
141: wrt 706.1,R*F[6]-(F[6]>9999.5)*wait 250;ret ..... Set Freq; wait 1/4 Second to Settle
142:
143: "READ X & Y,RANGE I.F. ATTEN, CONV TO MAG & PH":
144: "READ":
145: 1+Z;esb "VOLT" ..... Read X
146: V+E;2+Z;esb "VOLT" ..... Read Y
147: cll 'R/P'(E,V,B;A) ..... Rect. to Polar to find Mag.
148: if B>2.2;ato "UP" ..... Off Scale - Increase IF Atten.
149: if B<.4;ato "DWN" ..... Too Small - Decrease IF Atten.
150: "SCA":4+Z;esb "VOLT" ..... Just right - Now measure Mag on 8412
151: tnt(2V)+B;cll 'P/R'(B;A;K;Y) ..... Scale and Convert to Rect. to Store
152: if I>3;ato "data" ..... Test for Meas vs Calibration Data
153: "cal":X+E[M;N];Y+E[M+1;N];ret ..... Store Calibration Data
154: "data":X+X[M;N];Y+Y[M;N];ret ..... Store Measurement Data
155: "UP":Q+1+Q;if Q>6;6+Q;ert "OVERRNG";ato ..... More than 50 dB? Print Warning
156: ato "ATTEN"
157: "DWN":Q-1+Q;if Q<1;1+Q;ato "SCA" ..... Less than 0? No Way
158: "ATTEN":wrt 716,Q#I[0;1];wait 500 ..... Set IF Attenuator; wait 1/2 Second to Settle
159: ato "READ" ..... Go Around Again
160: "VOLT":0+W;2+(Q=1)*8+(Q=2)*4+D;ifor L=1 to D
161: fnt 1,"H",f.0,"AJ";wrt 705.1,Z
162: rot(rdb(705),8)+rdb(705)+V ..... Average Readings Twice on 50, 40, 30, 20; 6 times on 10
163: W+V+W;next L;N/D*V ..... and 10 Times on 0 dB IF Attenuator Settings
164: .0025V+V;ret

```

```

165:
166: "POLAR TO RECTANGULAR":
167: "P/R":p1cos(p2)+p3
168: p1sin(p2)+p4;ret

```



```

169:
170: "RECTANGULAR TO POLAR":
171: "R/P":r(p1p1+p2p2)+p3
172: 90(sen(p2)+(p2=0))+p4
173: if p1=0;ato +2
174: atn(p2/p1)+p4(1-sen(p1))+p4
175: ret

```



```

176:
177: "COMPLEX MULTIPLY": ..... p5 + jp6 = (p1 + jp2) (p3 + jp4)
178: "C*":p1p3-p2p4+p5
179: p1p4+p2p3+p6;ret

```

```

180:
181: "COMPLEX DIVIDE":
182: "C/":p3p3+p4p4+p7
183: (p1p3+p2p4)/p7+p5
184: (p2p3-p1p4)/p7+p6;ret ..... p5 + jp6 = (p1 + jp2) / (p3 + jp4)
185:

```

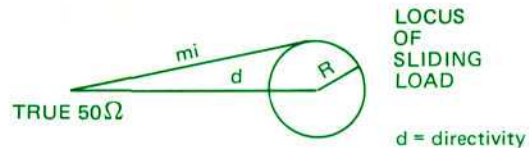

```

186: "FIND CENTER OF CIRCLE":
187: "CCENT":0+X+Y
188: for J=1 to 6
189: M=12+2J+G ..... Compute Index - Depend on Port 1/Port 2
190: X+E[G,N]→X;Y+E[G+1,N]→Y
191: next J
192: X/6+X→AC[1];Y/6+Y→BC[1] ..... Start with Average of 6 Positions
193: 0+K[5] ..... First Guess for Radius - Zero
194: for K=1 to 10 ..... Up to 10 Successive Approximations
195: 0+C→AC[2]→BC[2] ..... Set Current Radius
196: for J=1 to 6
197: M=12+2J+G

```

```

198: X-E[G,N]→AC[3];Y-E[G+1,N]→BC[3]
199: r(AC[3]AC[3]+BC[3]BC[3])→T
200: if T=0; goto "out"
201: AC[2]+AC[3]/T→AC[2];BC[2]+BC[3]/T→BC[2]
202: C+T→C
203: next J
204: C/6→C
205: AC[1]+AC[2]*C/6→X;BC[1]+BC[2]*C/6→Y

```

$$d = \frac{1}{6} \sum_{i=1}^6 m_i - \frac{1}{6} \sum_{i=1}^6 \frac{m_i - d}{|m_i - d|}$$

$$R = \frac{1}{6} \sum_{i=1}^6 |m_i - d|$$

```

206: if abs(C-K[5])<.005K[5]; goto "out" ..... Less than .5% Change in R - Finished
207: C+K[5];next K
208: "out":X+E[1,N];Y+E[2,N]; goto "INDEX" ..... Store d in ELOAD and on to Next Freq.
209:

```

```

210: "PRINTED DATA OUTPUT SECTION*****":
211:
212: "OUT":prt X# ..... Print Title
213: for H=1 to 4 ..... Up to Four Parameter
214: S[H]→M;if M<1; goto +10 ..... Last Parameter ? Jump Around
215: fnt 1,2/;c3;/;wrt 16.1,S[M,1] ..... Print S [ M ]
216: fnt 2," MHZ DB ANG";/;wrt 16.2
217: for N=1 to F[4]
218: cll 'R/P'(X[M,N],Y[M,N],T[1],T[2]) ..... Convert to dB, Angle
219: 20log(T[1])→T[1]
220: fnt 3,f5.0,x,f5.1,f5.0 ..... Print Frequency, Corrected Data
221: wrt 16.3,F[1]+(N-1)F[3],T[1],T[2]
222: next N
223: next H
224: fnt 4,7;/;wrt 16.4
225: goto "MEAS" ..... Back to connect another Device Under Test
226: end

```

ERROR MODEL BIBLIOGRAPHY

Hackborn, R.A. (May 1968), *An automatic network analyzer system*, *Microwave Journal* 11, 5, 45-52.

Hand, B.P. (Feb 1970), *Developing accuracy specifications for automatic network analyzer systems*, *HP Journal* 21, No. 6, 16-19.

Kruppa, W. and Sodomsy, K.F. (Jan 1971), *An explicit solution for the scattering parameters of a linear two port measured with an imperfect test set*, *IEEE Trans on MTT* 19 No. 1, 122-123.

Fitzpatrick, J.K. (Sept 1973), *A new direction for automatic network analyzer software*, *Microwave Journal* 16 No. 9, 65-68.

Rehnmark, S. (April 1974), *On the calibration process of automatic network analyzer systems*, *IEEE Trans. on MTT* 22 No. 4, 457-458.

Beatty, R. W. (June 1976), *Automatic Measurement of Network Parameters — A Survey — National Bureau of Standards Monograph* 151.