

H  
E  
W  
L  
E  
T  
T  
E  
R  
P  
A  
C  
K  
A  
R  
D

MICROWAVE  
STANDARDS  
PROSPECTUS

APPLICATION NOTE 21



A P P L I C A T I O N   N O T E   2 1



MICROWAVE  
STANDARDS  
PROSPECTUS

FOURTH EDITION  
JUNE 1960

1123

## CONTENTS

SECTION I	GENERAL	PAGE
	1 - 1 Microwave Standards . . . . .	I - 1
	1 - 2 Prospectus Description . . . . .	I - 1
	1 - 3 Traceability to the National Bureau of Standards . . . . .	I - 1
	1 - 4 Special Standards Requirements . . . . .	I - 1
	1 - 5 General References . . . . .	I - 2
SECTION II	FREQUENCY SYSTEMS	
	2 - 1 Reference Frequency Standards . . . . .	II - 1
	2 - 2 Accuracy Considerations . . . . .	II - 1
	2 - 3 Measurement Accuracies . . . . .	II - 3
	2 - 4 Frequency References . . . . .	II - 3
	2 - 5 House Standard System Diagrams . . . . .	II - 4
	Time Comparison	
	Frequency Comparison (Alternate)	
	2 - 6 Frequency System Diagrams . . . . .	II - 4
	Active Sources	
	Passive Elements	
	Coaxial Systems	
	Waveguide Systems	
SECTION III	ATTENUATION SYSTEMS	
	3 - 1 General Description . . . . .	III - 1
	3 - 2 Mismatch Errors . . . . .	III - 2
	3 - 3 Overall Accuracy . . . . .	III - 5
	3 - 4 Attenuation References . . . . .	III - 5
	3 - 5 Attenuation System Diagrams . . . . .	III - 6
	Square-Law Detection Systems	
	Calibration of Audio Standard	
	Coaxial System	
	Coaxial Dual Channel System (Alternate)	
	Waveguide System	
	Waveguide Dual Channel System (Alternate)	
	Linear Detection Systems	
	Coaxial System	
	Waveguide System	
	Parallel IF Substitution System (Alternate)	

**CONTENTS (CONT'D.)**

SECTION IV	IMPEDANCE SYSTEMS	PAGE
4 - 1	General Description . . . . .	IV - 1
4 - 2	Accuracy Considerations . . . . .	IV - 1
4 - 3	Impedance References . . . . .	IV - 2
4 - 4	Reflection Coefficient System Diagrams . . . . .	IV - 2
	Coaxial Systems	
	Coupling Factor	
	Directivity -- Dual Coupler and Single Coupler	
	Reflection Coefficient	
	Waveguide Systems	
	Coupling Factor	
	Directivity	
	Reflection Coefficient	
4 - 5	Impedance System Diagrams . . . . .	IV - 6
	Coaxial Systems -- Impedance	
	Coaxial Systems	
	Probe Detector Law	
	Residual Reflection	
	Impedance	
	Waveguide Systems	
	Probe Detector Law	
	Residual Reflection	
	Impedance	
SECTION V	POWER SYSTEMS	
5 - 1	General Description . . . . .	V - 1
5 - 2	Accuracy Considerations . . . . .	V - 2
5 - 3	Peak Power Measurement Techniques . . . . .	V - 2
5 - 4	Power References . . . . .	V - 3
5 - 5	Power System Diagrams . . . . .	V - 3
	Bolometric Measurement	
	Coaxial System	
	Waveguide System	
	Calorimetric Measurement	
	Coaxial System	
	Waveguide System	
	Barretter Mount Efficiency Measurement	
APPENDIX	Introduction	
	Table 1. Instrument Quantities	
	Table 2. Waveguide Quantities	
	Table 3. Miscellaneous Equipment	

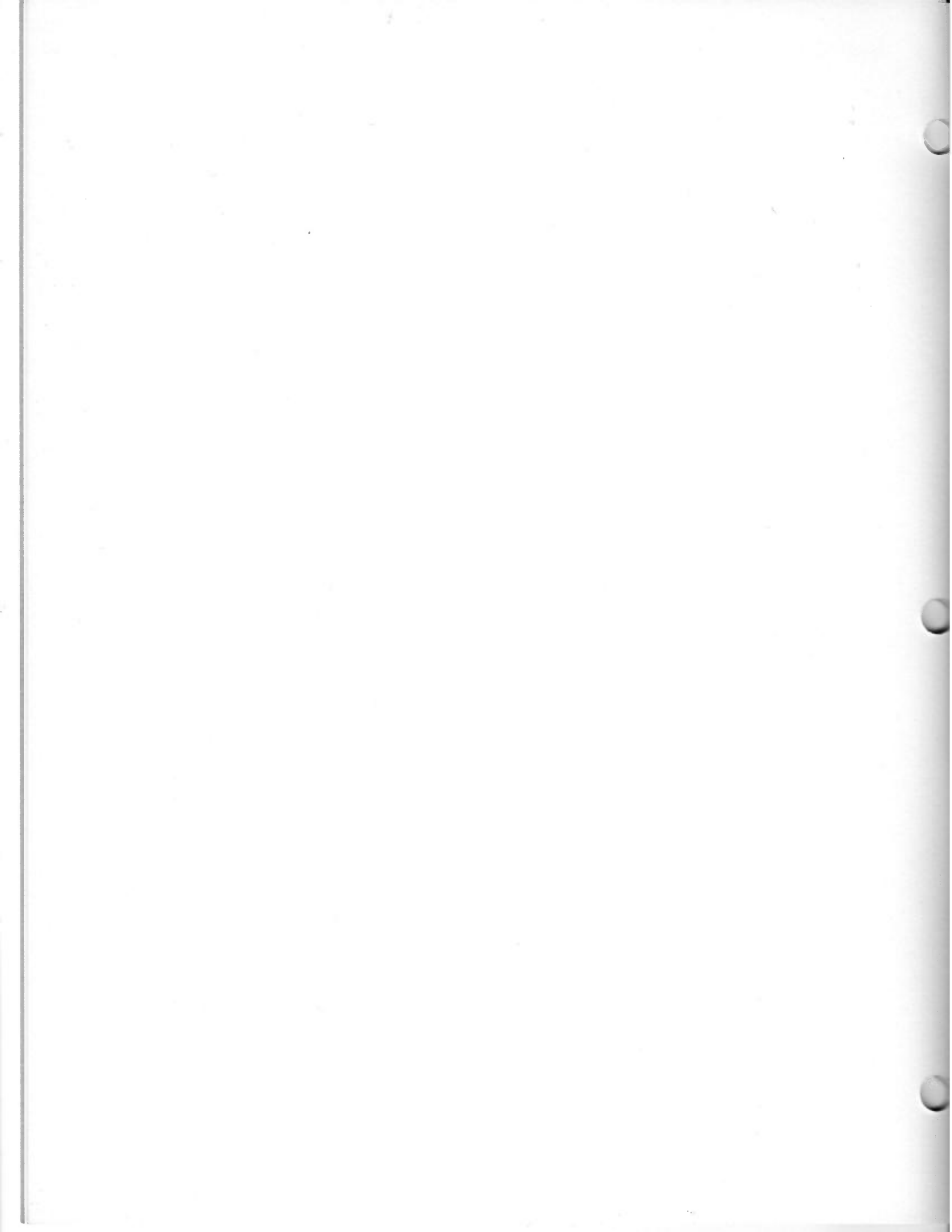

# SECTION I GENERAL

## 1-1 MICROWAVE STANDARDS

Microwave communications have created a demand for microwave devices of all kinds. To support the research, engineering, production and testing of these devices, new microwave standards laboratories have become necessary.

There are many important considerations involved in establishing a microwave facility. Three significant ones are:

- 1) Since accuracy is important, special measurement techniques are usually required.
- 2) A good compromise between accuracy and cost must be reached.
- 3) After a technique is developed, equipment compatibility must be considered.

This prospectus gives brief information on various techniques, some developed by  $\text{HP}$  engineers, used to make standards measurements. It provides a good compromise between cost and accuracy since the techniques permit use of commercially available instruments. Also, it provides a list of compatible equipment, including manufacturer, type and price, which a standards facility can employ to make the measurements shown. The frequency range covered varies with the measurement, but is generally from 10 mc to 40 kmc.

## 1-2 PROSPECTUS DESCRIPTION

This publication contains five sections and an appendix. Sections II through V discuss the general areas of standards measurements: frequency, attenuation, impedance and power. They present brief information on the measurement techniques developed and block diagrams of the compatible

equipment employed. Further, they list typical accuracies and ranges which can be achieved.

The Appendix contains a complete list of equipment, including the manufacturer, title, model number, price, and quantity for all instruments used to make the measurements in each frequency range. Thus it provides all the information necessary to establish a complete compatible standards facility for measuring frequency, attenuation, impedance and power. In some cases, alternate systems are shown in the block diagrams. To avoid confusion, the additional instruments required in these systems are not included in the equipment lists in the Appendix. However, there should be no difficulty in modifying the lists as required when an alternate system is adopted in place of or in addition to the one recommended.

## 1-3 TRACEABILITY TO THE NATIONAL BUREAU OF STANDARDS

In each of the following measurement sections the traceability of the calibrations to NBS is discussed, and the equipment to be submitted to NBS is specified. Information on the facilities and services of the National Bureau of Standards Electronic Calibration Center at Boulder, Colorado, is contained in NBS Report 5589.

## 1-4 SPECIAL STANDARDS REQUIREMENTS

Experience has shown that each standards measuring problem grows from an individual need. Each of the measuring systems described was designed to meet such an individual need. If you would like to have special attention given to your standards requirements, your inquiries are welcomed by the Hewlett-Packard standards group.

**1-5 GENERAL REFERENCES**

Since accuracy is extremely important in standards systems, special techniques are usually required. Because of limitations of space, the technical information presented here is very brief. However, more detailed information is available. The following list includes several comprehensive references. References dealing only with a specific type of measurement are listed in the appropriate section.

- 1) Hewlett-Packard Company, Application Note 38, "Microwave Measurements for Calibration Laboratories".
- 2) E. L. Ginzton, "Microwave Measurements", McGraw-Hill, New York, 1957.
- 3) C. G. Montgomery, "Techniques of Microwave Measurements", McGraw-Hill, New York, 1948 (Vol. 11 of the Rad. Lab. series).
- 4) M. Wind and H. Rapaport, "Handbook of Microwave Measurements", Polytechnic Institute of Brooklyn, New York, 1955.

# SECTION II FREQUENCY SYSTEMS

## 2-1 REFERENCE FREQUENCY STANDARDS

One of the essential items in a standards laboratory is a frequency standard. This unit is a highly stable oscillator which provides known reference frequencies and is capable of comparison with the signals broadcast by WWV or other frequency-standard stations. An electronic counter such as the  $\Phi$  Model 524 incorporates such an oscillator and can be regularly checked against WWV. However, a counter is a useful and versatile instrument which should be, as far as possible, available at all times, for use at any location desired. Hence, the most flexible arrangement is to have an oscillator specifically designated as the "house standard", fixed in one location for frequent and regular comparison with WWV. The oscillator in the frequency counter can then be calibrated as often as required by comparison with the house standard. For the highest measurement accuracy, the frequency counter can be operated using the house standard as an external oscillator.

## 2-2 ACCURACY CONSIDERATIONS

Direct frequency comparisons against WWV at a distance from Washington are subject to errors due to fluctuations of the ionosphere which cause Doppler shift of the received frequency. In order to increase accuracy by minimizing this effect, provision may be made for making time comparisons, using the time ticks broadcast by WWV. In this procedure, the total time elapsed over a given period, as indicated by a clock driven by the oscillator, is compared with the time elapsed as indicated by WWV. Over a long period, this averages out the short-term fluctuations, and allows the average oscillator frequency to be determined to very nearly the accuracy of the transmitted signal at WWV. The following table which gives the pertinent figures in parts in  $10^{10}$ , demonstrates the necessity of time comparisons for realizing the greatest possible accuracy. These values are, of course, all approximate.

Relative accuracy by Direct  
Frequency Comparison . . . . .  $\pm 3000/10^{10}$

Short-Term Stability of Oscil-  
lator (100E or 524) . . . . .  $\pm 300/10^{10}$

Short-Term Stability of Oscil-  
lator (103AR) . . . . .  $\pm 5/10^{10}$

Relative Accuracy by Time Com-  
parison, 24-hr period (depends upon  
distance from WWV and reception  
conditions) . . . . .  $\pm 1/10^{10}$  to  $\pm 100/10^{10}$

The block diagrams in paragraph 2-5 show alternate frequency standard setups and indicate the attainable accuracy at a distance from WWV. For time comparisons, either the 103AR Frequency Standard or the 100ER Frequency Standard may be used as the basic standard. The 103AR provides greater stability, as shown above, while the 100ER, designed for use as a secondary standard, provides a greater variety of outputs. The 113AR Frequency Divider and Clock provides 1 pulse per second to trigger the oscilloscope which displays the WWV ticks. At the beginning of the comparison period, a reference position for the ticks on the trace is established. At the end of the comparison period, the pulses from the 113AR are shifted in time by adjustment of a calibrated shifter to restore the ticks to the same reference position on the oscilloscope. The shifter is then read to determine the difference in elapsed time indicated by the clock relative to WWV. For frequency comparisons only, the 113AR is omitted. Because of the lower attainable accuracy in this case, only the standards with lower stability are shown in the diagram.

When the 524 specified in all the measurement setups is calibrated against the house standard or operated with the house standard as an external oscillator, the accuracy of all the measurements indicated is traceable to NBS through WWV.



### 2-3 MEASUREMENT ACCURACIES

Frequencies up to 10 mc are measured directly with the 524 Frequency Counter. The accuracy at 10 mc is essentially that of the internal or external standard for a gate time of ten seconds. However, at lower frequencies the  $\pm 1$  count tolerance inherent in any gate and counter instrument must be taken into account and causes the possible error to increase as the frequency is lowered. The relative effect of the  $\pm 1$  count is, of course, reduced as the gate time is increased.

Accuracy at lower frequencies can be increased, however, by making period measurements. Although, ideally, the accuracy with period measurements improves as the frequency is reduced, this improvement is not necessarily realized in practice. If the signal consists of square waves or pulses with a fast rise time, the internal standard accuracy may be reached, but with sine waves any noise present causes gate trigger accuracy to deteriorate as the rate of rise of the signal decreases. Consequently, a lower limit is put on the possible error for period measurements of sine waves. In Figure 2-1, this limit is based on a 40-db signal-to-noise ratio. The accuracy can be increased, however, by taking longer and longer samples of the unknown. With the 524 alone, one- and ten-period measurements may be made. With the addition of the Model 526C Period Multiplier, measurements can be made up to 10,000 periods, allowing the basic accuracy of the 524 to be attained. The accuracy attainable under any conditions is shown in Figure 2-1. The curves can readily be extrapolated for an external standard of greater accuracy.

An examination of the curves of Figure 2-1 shows that measurements with a maximum measurement time of 10 seconds must be made as shown below for the greatest accuracy. Slightly greater accuracy

Period Measurements	Count 10 mc for:
Below - 1 cps	1 period
1 cps to 10 cps	10 periods
10 cps to 100 cps	100 periods
100 cps to 1 kc	1,000 periods
1 kc to 10 kc	10,000 periods
Above - 10 kc	Measure frequency with 10-second gate

can be achieved when measuring noise-free signals up to 1 kc by taking 10 times as many periods, but the measurement time will then be from 10 to 100 seconds.

To make measurements above 10 mc the 10 mc frequency available in the 524 is multiplied an appropriate amount and then heterodyned with the unknown so that the difference falls within the range of the 524. Two units are used to extend the range in this way. The 525A Frequency Converter operates from 10 to 100 mc, the 525B Frequency Converter from 100 to 220 mc.

Above 220 mc, measurements are made using a Model 540B Transfer Oscillator. The 540B contains a 100-220 mc oscillator which is tuned so that one of its harmonics beats with the unknown. The order of the harmonic is determined by a simple technique and the transfer oscillator frequency is measured by the 524-525B combination. From 12.4 to 40 kmc, an external mixer is used. In addition, from 18 to 40 kmc, the harmonics from the 540B harmonic generator are amplified and applied to an external harmonic generator to get sufficient harmonic power.

Above 220 mc, the short-term 540B oscillator stability and operator error in setting to zero-beat must also be taken into account. The lowest attainable error of comparison due to these factors amounts to about  $\pm 1/10^7$  under the best conditions. This should be added to the other possible errors above.

Measurement of the resonant frequency of passive elements is made by adjusting the frequency of the signal source for resonance in the passive element, and then measuring the frequency. The accuracy depends upon the Q of the element and upon the skill of the operator in adjusting for exact resonance. With an amplitude-modulated system, the 415B is used as an indicator. With frequency-modulation, an oscilloscope is the indicator.

### 2-4 FREQUENCY REFERENCES

- 1) "Standard Frequencies and Time Signals", Letter Circular LC 1023, National Bureau of Standards, Boulder, Colorado.
- 2) W. D. Myers, "Simplified Microwave Frequency Measurements using the 10 MC Frequency Counter", Hewlett-Packard Journal, Vol. 3, No. 5-6, Jan. - Feb., 1952.

- 3) D. Hartke, "A Simple Precision System for Measuring CW and Pulsed Frequencies up to 12,400 MC", Hewlett-Packard Journal, Vol. 6, No. 12, August, 1955.

Notes: The 120A Oscilloscope, or equivalent, is recommended for use with the 540B for greater flexibility in signal presentation, although it is not essential.

The 540A may be used up to 5 kmc in place of the 540B. With a 934A Harmonic Mixer and a P932A Harmonic Mixer it may be operated from 5 to 18 kmc.

**2-5 HOUSE STANDARD SYSTEM DIAGRAMS**

**A. TIME COMPARISON**

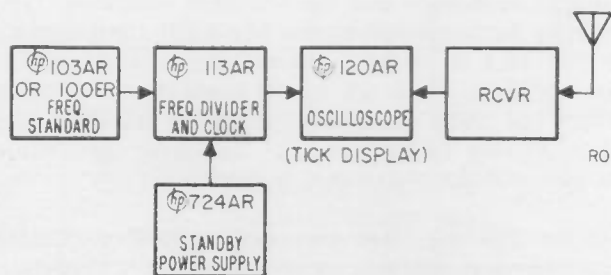

Stability -  $\pm 5/10^{10}$  per day (103AR)  
 $\pm 3/10^8$  short-term,  $\pm 5/10^8$  per week (100ER).

Accuracy of comparison with WWV - approximately  $\pm 1/10^8$  over 24-hour period under poor conditions, to  $\pm 1/10^{10}$  under good conditions.

**B. FREQUENCY COMPARISON (Alternate)**

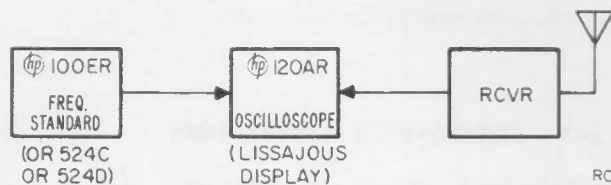

Stability -  $\pm 3/10^8$  short-term,  $\pm 5/10^8$  per week.

Accuracy of comparison with WWV - approximately  $\pm 3/10^7$ .

**2-6 FREQUENCY SYSTEM DIAGRAMS**

**A. ACTIVE SOURCES**

Below 1 cps to 10 kc:

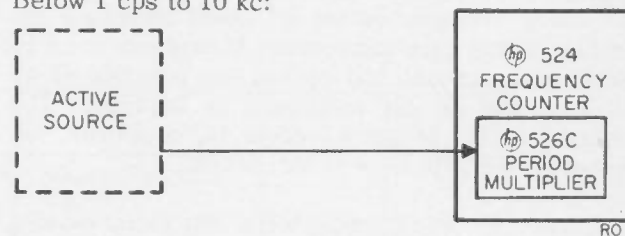

up to 1 cps	count 10 mc for	1 period
1 cps to 10 cps	" " "	10 periods
10 cps to 100 cps	" " "	100 periods
100 cps to 1 kc	" " "	1,000 periods
1 kc to 10 kc	" " "	10,000 periods

10 kc to 10 mc:

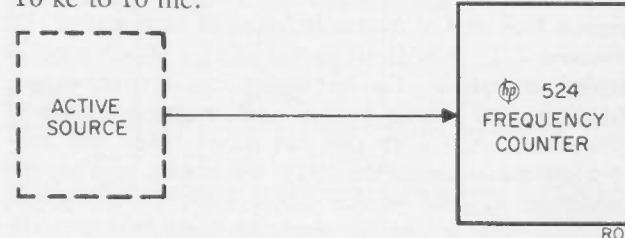

Count unknown using 10-second gate

10 mc to 100 mc:

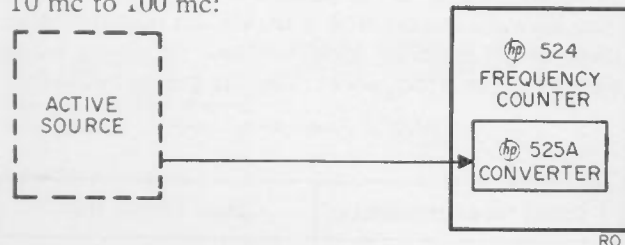

100 mc to 220 mc:

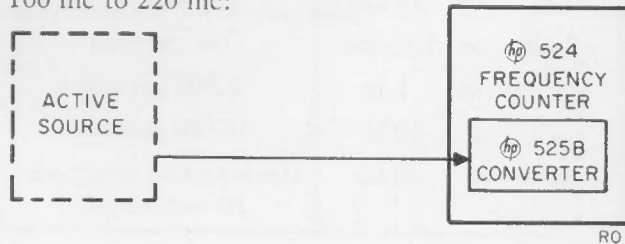

220 mc to 12.4 kmc:

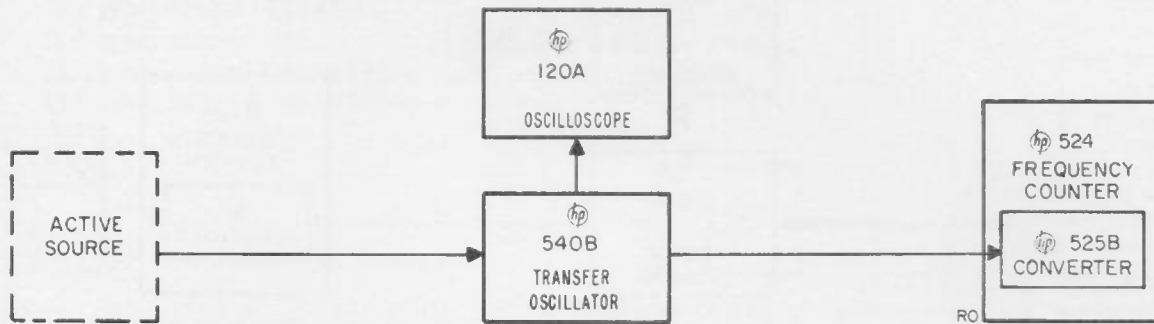

12.4 to 18 kmc:

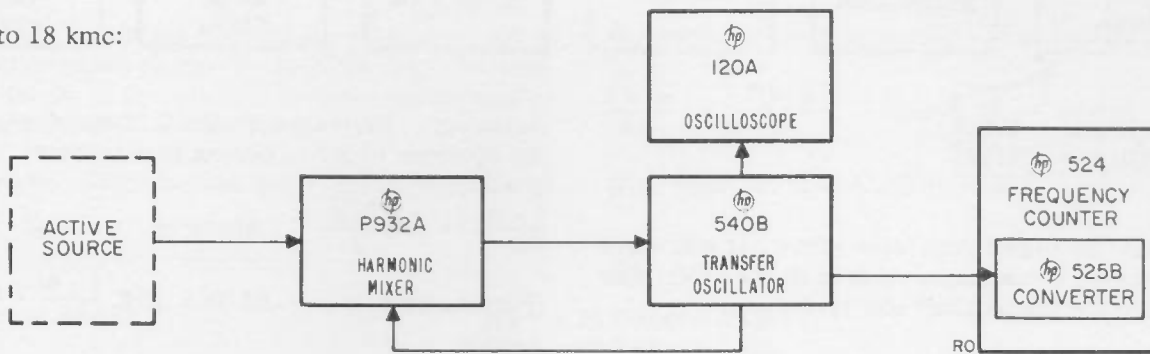

18 kmc to 40 kmc:

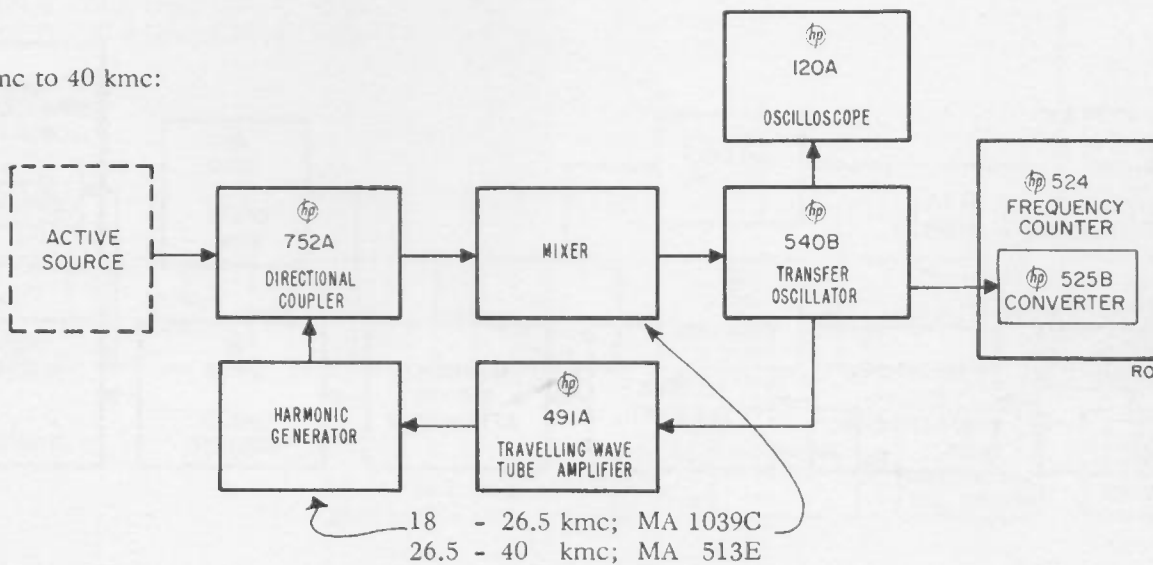

Accuracy:  $\pm 1$  part in  $10^7$ .

B. PASSIVE ELEMENTS -- 1) Coaxial Systems

10 to 1230 mc:

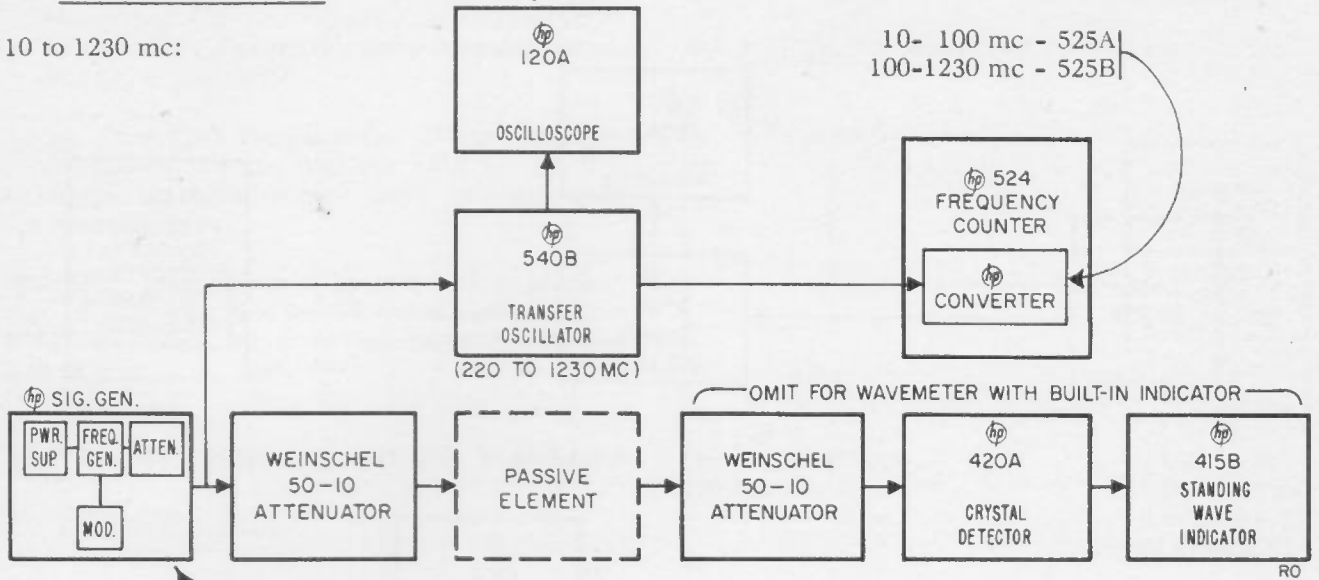

10 - 480 mc - 608C  
450-1230 mc - 612A

Accuracy: Depends upon the Q of the element and the operator error in setting to maximum:

$$\frac{f - f_0}{f_0} = \frac{.707\sqrt{\alpha}}{Q} \quad \text{where } \alpha = \text{error}$$

Modulate the signal generator with a 1 kc sine wave and tune for a maximum reading on the 415B, then measure the signal generator frequency.

(For example, if  $\alpha = .02 \text{ db} = .23\%$ ,  $\frac{f - f_0}{f_0} = \frac{.034}{Q}$ )

800 to 4200 mc:

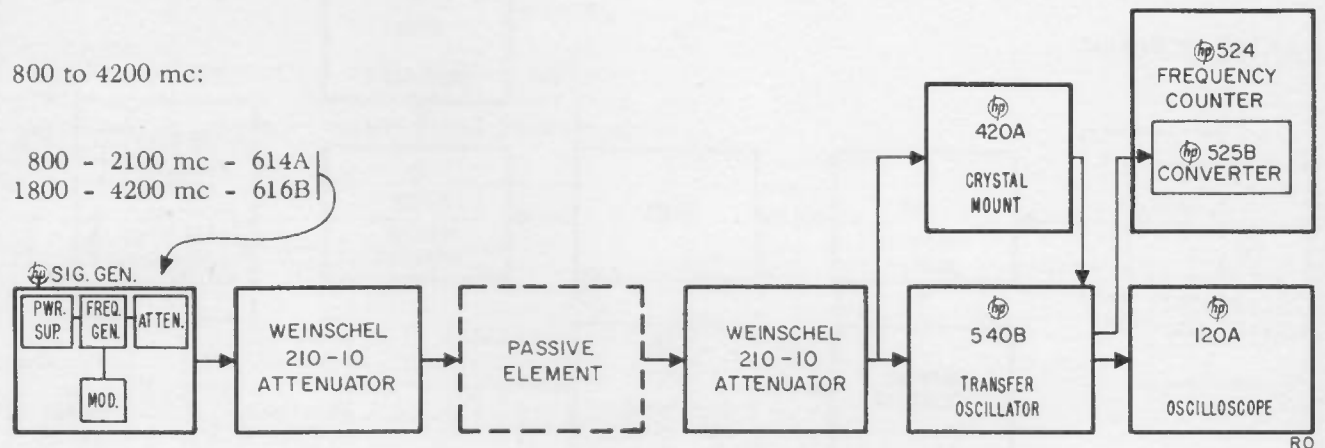

Frequency modulate the signal generator for a resonance curve on the oscilloscope, tune the 540B for a birdie at the top of the resonance curve, and then measure the 540B frequency.

the operator error in setting to maximum:

$$\frac{f - f_0}{f_0} = \frac{.707\sqrt{\alpha}}{Q} \quad \text{where } \alpha = \text{error}$$

Accuracy: Depends upon the Q of the element and

(For example, if  $\alpha = .02 \text{ db} = .23\%$ ,  $\frac{f - f_0}{f_0} = \frac{.034}{Q}$ )

2) Waveguide Systems 2.6 to 18.0 kmc:

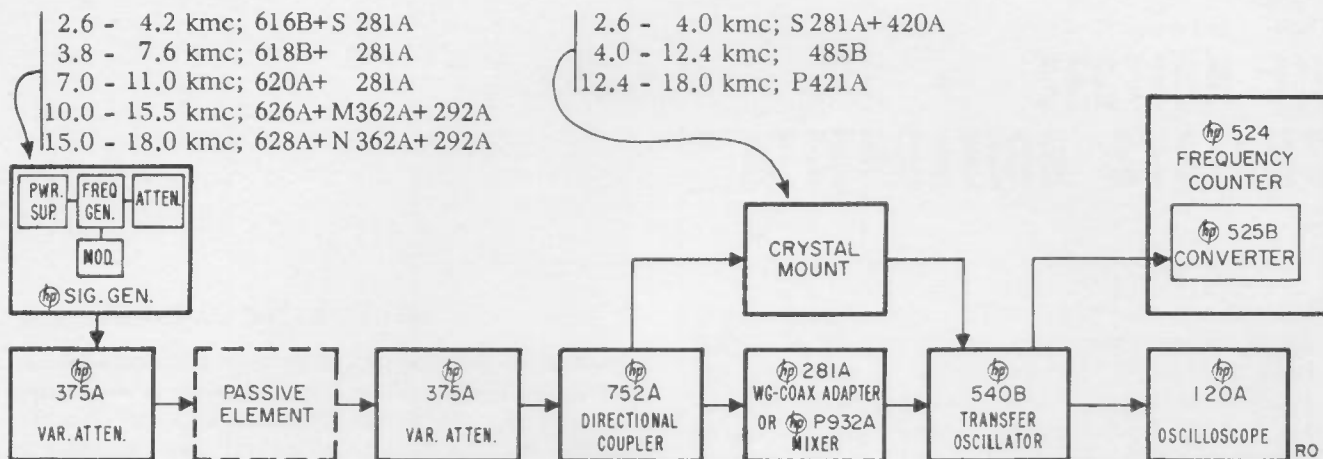

Frequency modulate the signal generator for a resonance curve on the oscilloscope, tune the 540B for a birdie at the top of the resonance curve, and measure the 540B frequency.

the operator error in setting to maximum:

$$\frac{f - f_0}{f_0} = \frac{.707\sqrt{\alpha}}{Q} \quad \text{where } \alpha = \text{error}$$

Accuracy: Depends upon the Q of the element and

(For example, if  $\alpha = .02 \text{ db} = .23\%$ ,  $\frac{f - f_0}{f_0} = \frac{.034}{Q}$ )

18.0 to 40.0 kmc:

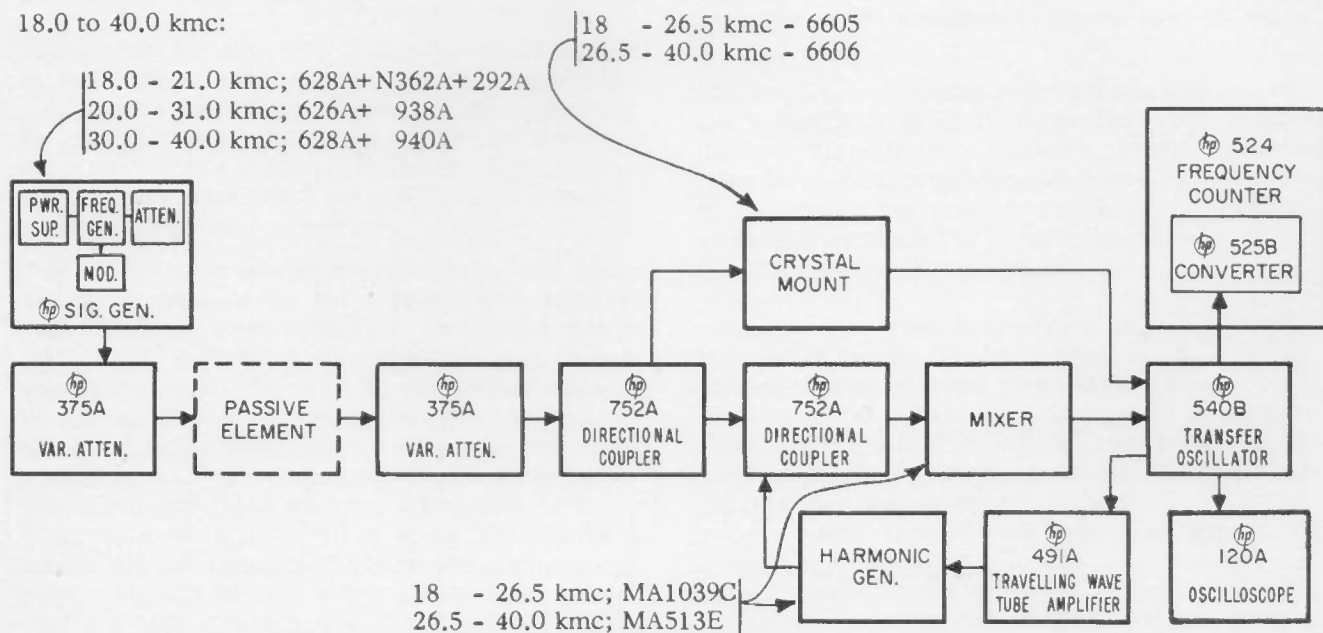

Frequency modulate the signal generator for a resonance curve on the oscilloscope, tune the 540B for a birdie at the top of the resonance curve, and then measure the 540B frequency.

the operator error in setting to maximum:

$$\frac{f - f_0}{f_0} = \frac{.707\sqrt{\alpha}}{Q} \quad \text{where } \alpha = \text{error}$$

Accuracy: Depends upon the Q of the element and

(For example, if  $\alpha = .02 \text{ db} = .23\%$ ,  $\frac{f - f_0}{f_0} = \frac{.034}{Q}$ )

Faint paragraph of text, likely the beginning of a section or a list item.



Faint paragraph of text, possibly a continuation of the previous section.

Faint paragraph of text, possibly a continuation of the previous section.

Faint paragraph of text, possibly a continuation of the previous section.



Faint paragraph of text, possibly a continuation of the previous section.

Faint paragraph of text, possibly a continuation of the previous section.

Faint paragraph of text, possibly a continuation of the previous section.

## SECTION III ATTENUATION SYSTEMS

### 3-1 GENERAL DESCRIPTION

Attenuation is measured by two different techniques: square-law detection with audio substitution, and linear detection with IF substitution. Attenuators calibrated with these techniques can, of course, be used as standards for direct rf substitution.

The only useful square-law detector for accurate measurements is the barretter. Variations in audio output which result from detection of a varying modulated rf signal can be measured accurately with an audio attenuator. Sources of error are departure from square-law response by the barretter, noise, variation in the modulation frequency, calibration of the audio attenuator, and source amplitude instability.

The region for accurate measurements is limited at the higher levels by departure from square law and at the lower levels by noise. This region may be determined by repeatedly measuring the same fixed amount of attenuation while varying the signal level. The measured attenuation will decrease at either extreme.

Any variation in modulating frequency can cause an error because the low signal levels involved require tuned amplification. The effect can be eliminated by deriving the modulation from a frequency standard. The 415B Standing Wave Indicator is the amplifier and standard audio attenuator. Since the expanded scale covers 2 db and the range switch is in 10 db steps, the most accurate measurements are made when the attenuation is within 2 db of a multiple of 10 (8 to 12, 18 to 22 etc.), where the resolution of the expanded scale may be used. For continuous coverage with high resolution and high accuracy, the Weinschel BA-5 in the Dual Channel setup described below may be substituted for the 415B. Either may be accurately calibrated with a ratio transformer which should be submitted to NBS for calibration.

Amplitude instability can add as much as .05 db to the error in a particular reading with ordinary

signal generators. This error can be reduced with a level monitor or by averaging many readings, but for highest accuracy the Weinschel Dual Channel system may be used. Here the rf power is fed through two channels, detected, and the audio outputs nulled. AF attenuation is substituted for rf attenuation in one channel while maintaining the null. So, with this system normal source fluctuations have negligible effect on accuracy.

The range possible in one step with square-law detection is from 20 to 30 db, depending on the accuracy desired. The total range, using more than one step, depends upon the source power, and is about 40 db with a 0 dbm source, 50 db with a +10 dbm source, etc. This can, of course, be extended with increasing error due to noise.

The accuracy of measurements made with square-law detection is basically traceable to NBS through the ratio transformer. However, careful evaluation must be made of the additional errors in the system to determine the overall results. In addition, mismatch errors must be taken into account. These are discussed in paragraph 3-2.

Although the great majority of attenuation measurements can be made with square-law detection, measurements of more than 30 db attenuation in one step or 50 db total attenuation generally require linear detection. This system uses a local oscillator and mixer to obtain an IF signal. IF attenuation is then substituted for the unknown rf attenuation. With the AIL 130 receiver and piston attenuator, the range possible with most mixers in one step is from 30 to 50 db, limited by non-linearity at the high power level, around -40 dbm, and noise at the low power level, around -80 dbm. With usual source powers, a total attenuation range of 80 to 100 db, in two or more steps, is generally attainable. Somewhat greater range may be obtained by modulating the signal source and using the 415B as indicator instead of a dc meter. This gives a narrower effective bandwidth with

consequent reduction in noise, although, as before, the modulation must be derived from a frequency standard to avoid introducing additional error.

In the linear detection system there are several sources of error in addition to most of those encountered in square-law detection. The signal source and local oscillator must be very stable in frequency as well as amplitude to maintain a constant beat frequency. The short-term instability of ordinary sources will add from .01 to .10 db error to a measurement.

To get the best overall accuracy, the linear region of each element in the IF system should be determined with repeated measurements on the same fixed amount of attenuation while varying the level at the element in question. Levels and gains should always be adjusted to stay well within these linear regions. Signal sources should be used only after thorough warm-up. Usually, attenuation steps should be limited to about 20 db. For large attenuations, overlapping measurements can be made in steps of 10, 20, and possibly 30 db, and average taken to minimize random errors. The indicator used should have high resolution -- .01 db or better.

The AIL attenuator should be submitted to NBS for calibration as the basic standard. Again, however, to determine the accuracy actually achieved, an error analysis should be made, evaluating each source.

A somewhat more elaborate system using parallel IF substitution instead of series substitution is incorporated in the Weinschel Model VM-1B Standard Attenuator Comparator. This system has a dynamic range of over 90 db with great accuracy. Weinschel oscillators used with this system are available up to 10.5 kmc. Full accuracy is possible up to 4 kmc with oscillators which have frequency following circuits.

### 3-2 MISMATCH ERRORS

In addition to the errors inherent in the measurement system, there are mismatch considerations. In general, an attenuator which is inserted into the system has a mismatch loss at each end, while there is another mismatch loss when the system is joined together without the attenuator. The measured attenuation includes the difference between these losses. There are two methods of taking mismatch losses. One method employs tuners to tune out the mismatches completely under both

conditions. In this case, the measurement is made on the actual attenuation, but any losses in the tuners which vary with their settings introduce errors which are difficult to evaluate accurately. The other method (more common) is to measure "insertion loss", which is defined to include the mismatch loss at each end of the attenuator when it is inserted into a system with unity swr looking both ways at the insertion point. This system is more suitable when several units are to be checked and gives more reproducible results. An error occurs due to the fact that the insertion point swr's are never quite unity, but if the swr's involved are all measured, the possible error is readily evaluated by means of a mismatch loss chart. The swr's at the insertion point can be made practically unity by tuning if greatest accuracy is required. However, a much more convenient but somewhat less accurate system is to feed the signal in from the source and out to the detector through attenuators or directional couplers with very low swr. In this case the range of measurement is reduced by the coupling factors or attenuations introduced.

Figures 3-1 and 3-2 show the maximum and minimum possible losses for any combination of source and load swr's up to values of 2. The following example shows how they are used. Consider a system in which the source and load swr's at the insertion point are 1.05, while the attenuator swr is 1.15 at each end. It can be seen from the charts that the mismatch loss at each end after insertion into an ideal system would be .02 db, so there should be .04 db included in the insertion loss. Actually, the reading before insertion may include a loss of from 0 to .01 db, while the reading after insertion may include a loss of from .01 to .04 db at each end, or a total of .02 to .08 db. Figure 3-3 shows how the measured value of attenuation can be in error by +.04 to -.03 db.

In many cases, variable attenuators are not subject to mismatch errors, since the errors may be constant as the attenuation is varied, and thus cancel out.

If desired, high-quality fixed attenuators such as the  $\Phi$  Model 372 Precision Attenuator may be submitted to NBS for calibration as reference standards with which to check the accuracy of the measurement setup. Since NBS calibrates to .2 db or 1% of the attenuation in db, whichever is greater, the calibration would be accurate to .2 db for both 10 and 20 db models. Again, the mismatch errors must be carefully evaluated and taken into consideration.

# POWER LOSS CURVES

(SOLID LINES INDICATE MINIMUM POWER LOSS, BROKEN LINES MAXIMUM POWER LOSS)

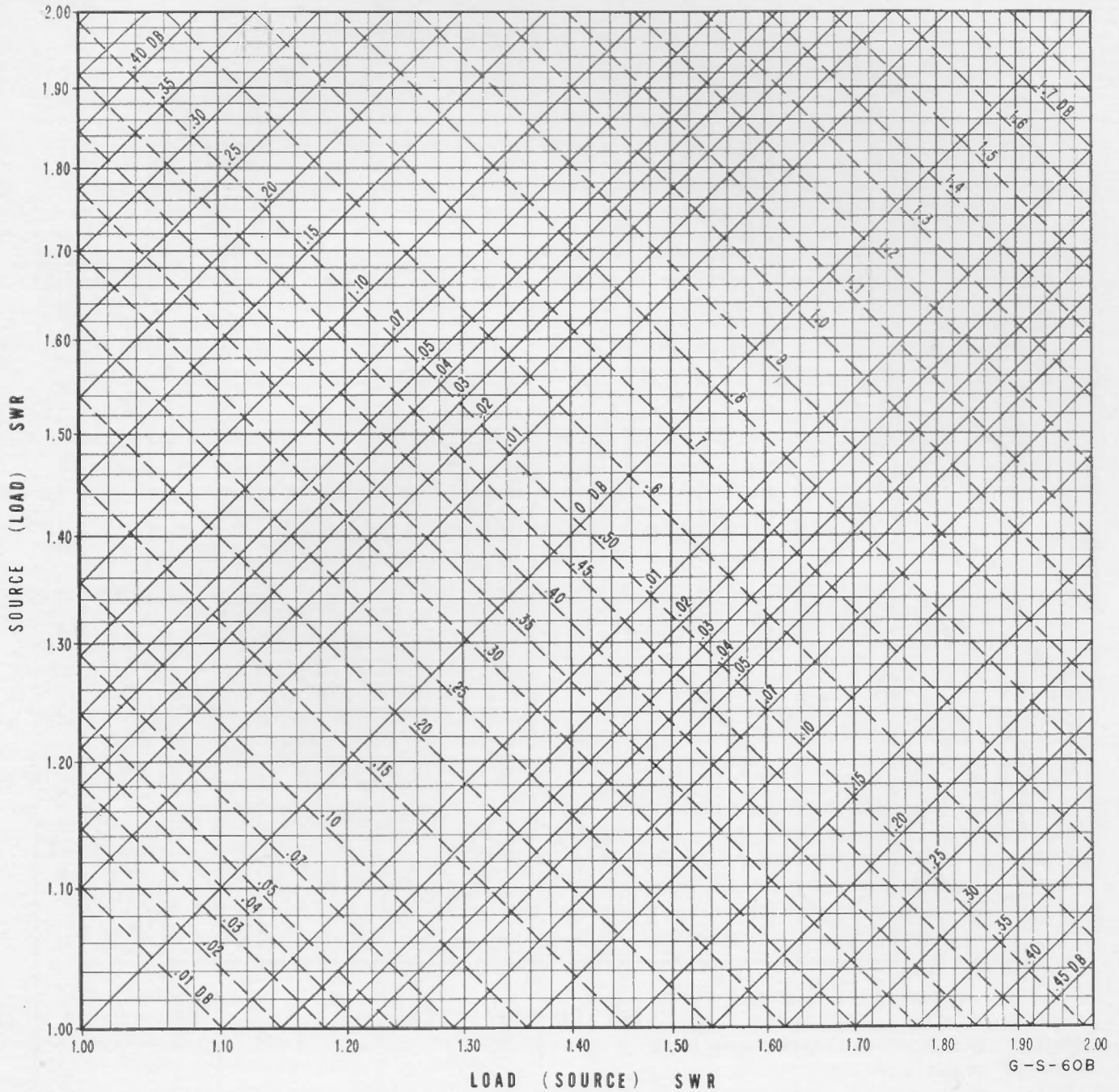

Figure 3-1

# POWER LOSS CURVES

(SOLID LINES INDICATE MINIMUM POWER LOSS, BROKEN LINES MAXIMUM POWER LOSS)

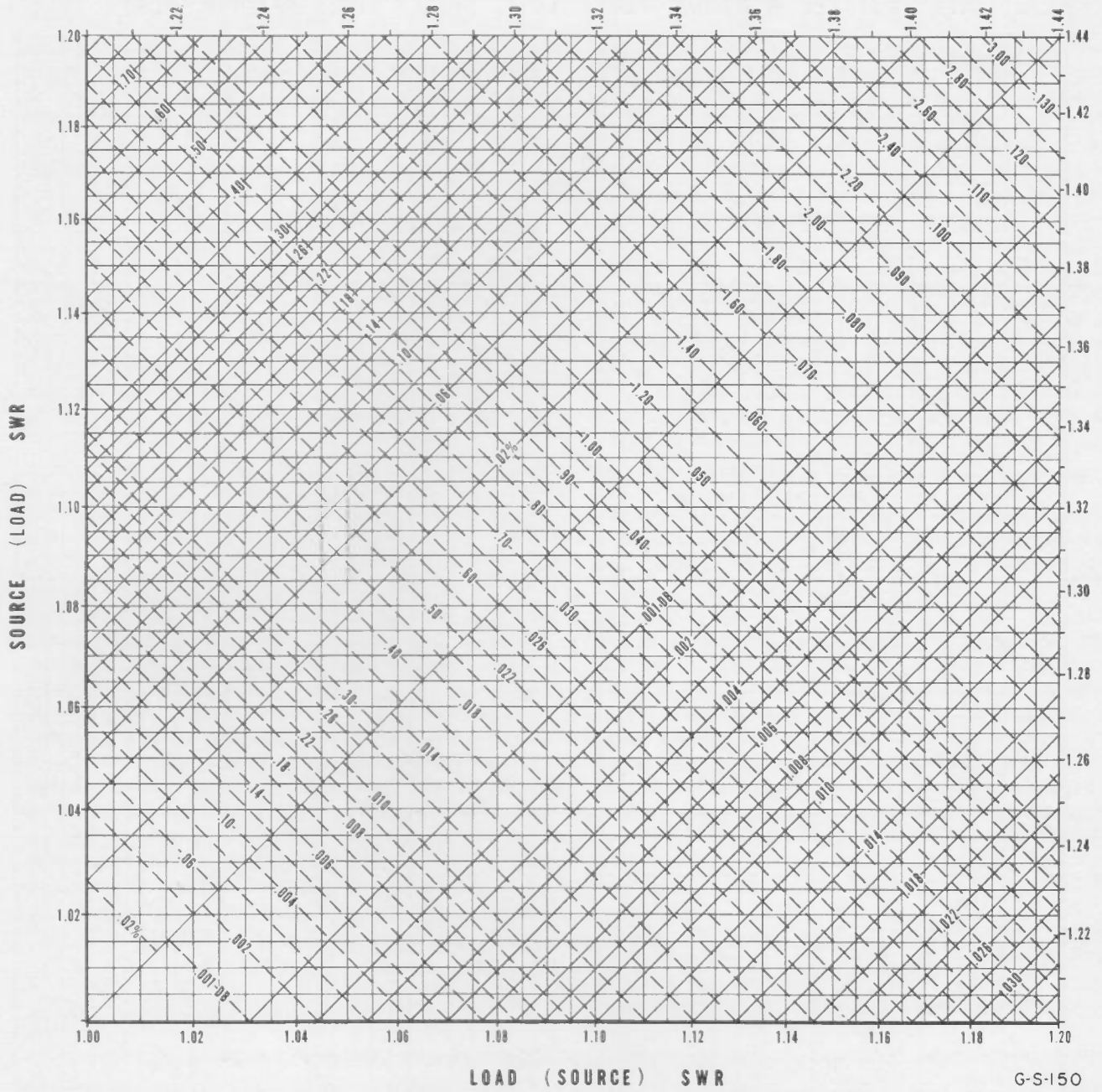

Figure 3-1

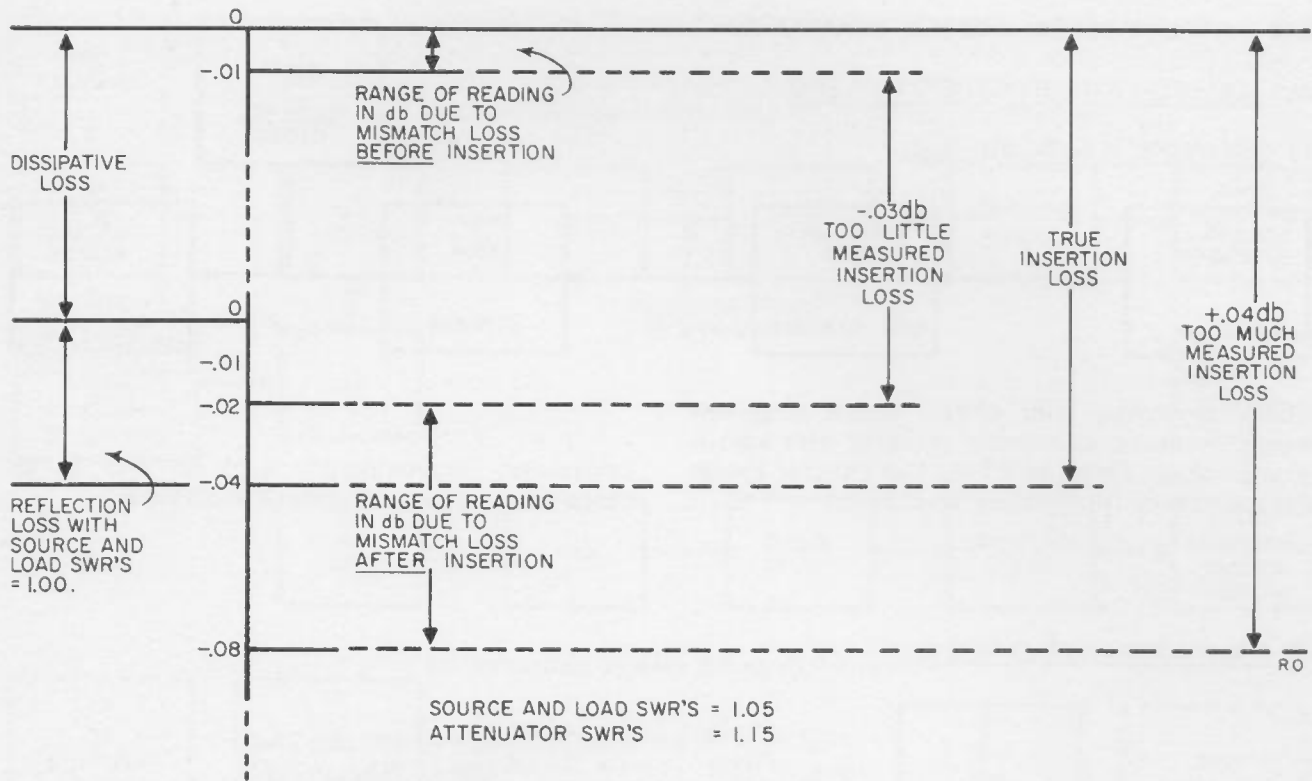

Figure 3-3. Example of Evaluation of Mismatch Losses

**3-3 OVERALL ACCURACY**

No blanket figures can be given for the accuracy attainable in any attenuation measurement. It is necessary instead to evaluate all the individual errors applying to a particular measurement. Some typical magnitudes and types of error are given in the table below to serve as a general guide.

Types of Error	Square-Law	Linear
Operator	± .01 db	± .01 db
Source stability	± .02 db	± .05 db
Non-linearity, 20 db step	± 0 db	± 0 db
30 db step	+0, -.02	± 0 db
40 db step	---	+0, -.05
Attenuator	± .02 db	(0.5db + 0.1% of db reading)
Mismatch (1.05 source and load, 1.15 attenuator)	+ .04, -.03	+ .04, -.03

Of these, operator and source stability errors can be reduced by averaging repeated measurements. Source stability error can be reduced or eliminated by using a level monitor or the dual-channel system (for square-law). Non-linearity can be reduced or eliminated by taking sufficiently small steps. Attenuator error is the "traceable to NBS" portion, which includes the overall 415B calibration by means of a certified ratio transformer for square-law detection or the NBS calibration accuracy on the piston attenuator for linear detection. Mismatch error can be reduced by reducing the source and load swr's as far as possible.

**3-4 ATTENUATION REFERENCES**

- 1) R. W. Beatty, "Mismatch Errors in the Measurement of UHF and Microwave Variable Attenuators", Journal of Research, NBS, Vol. 52, No. 1, January, 1954 (RP 2465).
- 2) Application Note No. 4, "Dual Channel Insertion Loss Test Set", Weinschel Engineering Co., Kensington, Maryland.

### 3-5 ATTENUATION SYSTEM DIAGRAMS

#### A. SQUARE-LAW DETECTION SYSTEMS

##### 1) Calibration of Audio Standard:

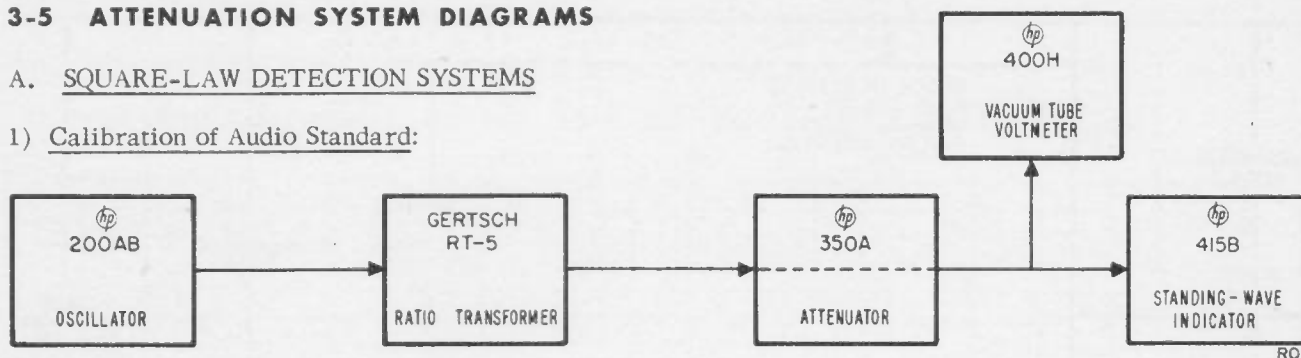

Check sensitivity with 400H. Check range-to-range accuracy and meter tracking with appropriate voltage ratios on RT-5. Use 350A for lowest ranges to keep transformer level high.

Accuracy: Approximately  $\pm .01$  db over 30 db range (limited by resolution of 415B scale).

##### 2) Coaxial system 10 to 4200 mc:

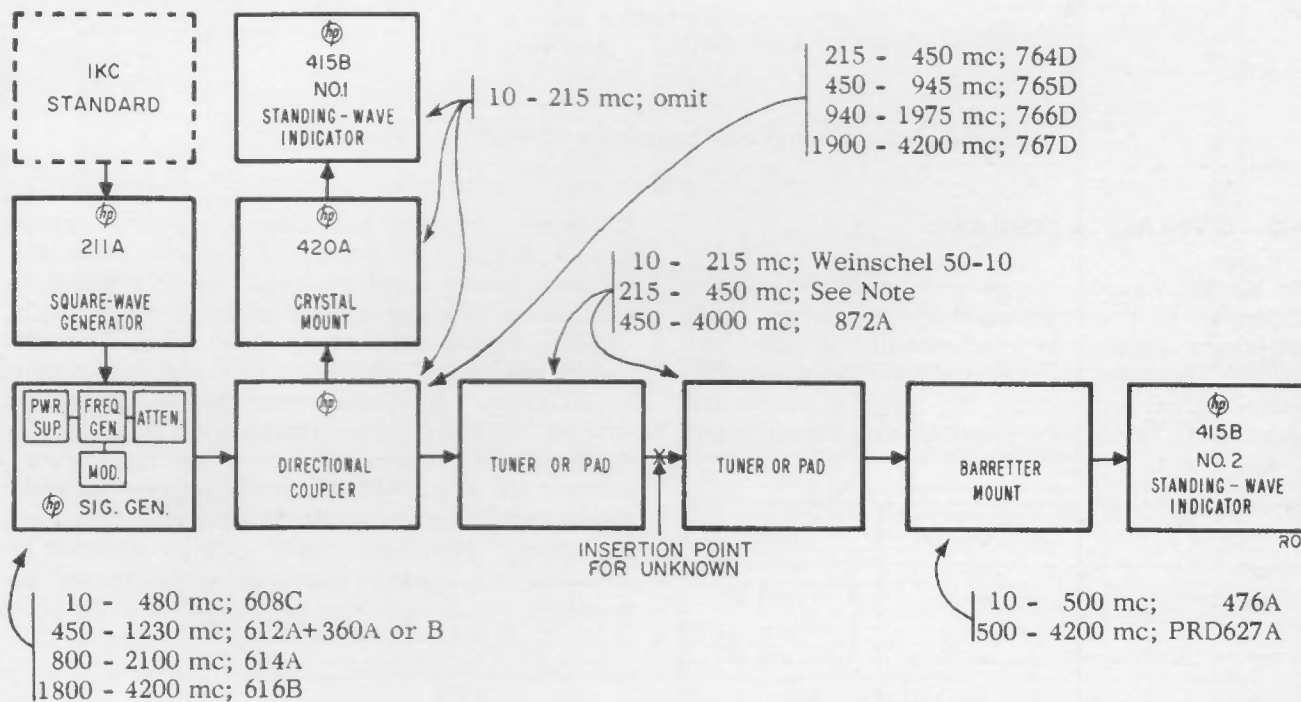

#### NOTE

If 872A's are used in the range 215 to 450 mc to reduce the errors, it may be necessary to use the 1/4 wavelength line supplied with the K04 999C to extend the tuning range down to 215 mc. One of the "350 mc" lengths can be used on the second 872A if required.

\* \* \*

Measure impedances looking both ways at insertion point and adjust 872A's, if used, for swr of 1.05 or less. Set reference reading on 415B No. 2 with system as shown. Insert attenuator under test and read attenuation on 415B No. 2.

Range: 20 to 30 db in one step. Using tuners, approximately 40 db total with 0 dbm source, 50 db with +10 dbm source, etc. 20 db less range using pads.

3) Coaxial Dual Channel System (Alternate):

See diagram 2 for instrument designations not specified below.  
See Weinschel Engineering Application Note No. 4 for full discussion.

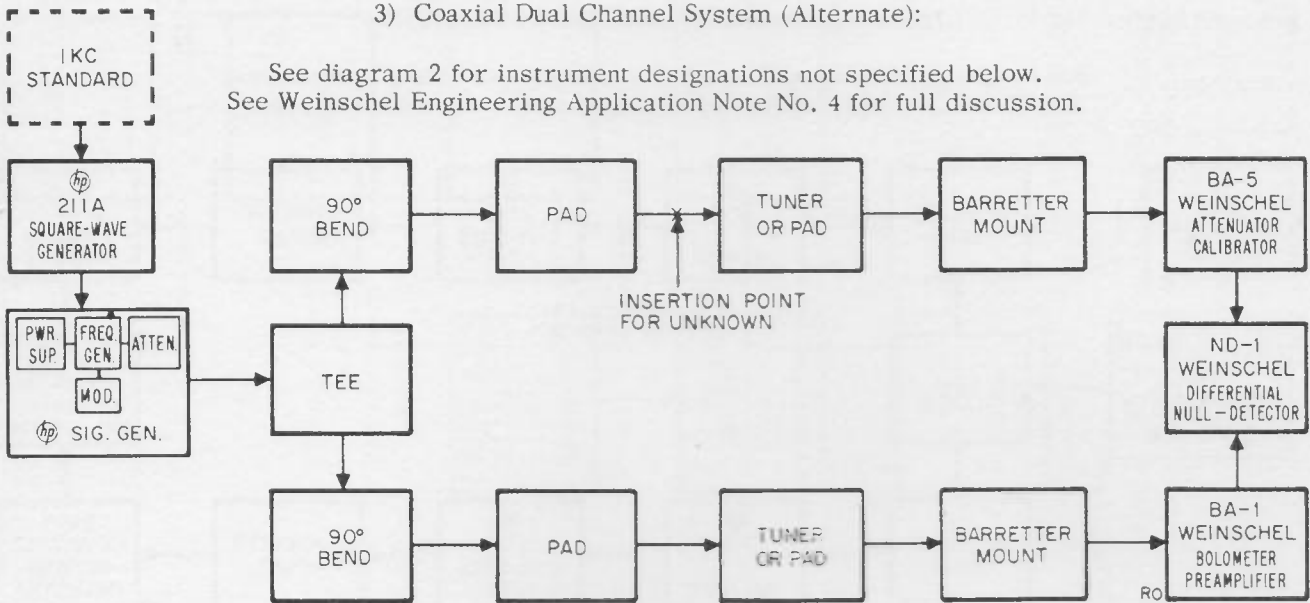

4) Waveguide System 2.6 to 40.0 kmc:

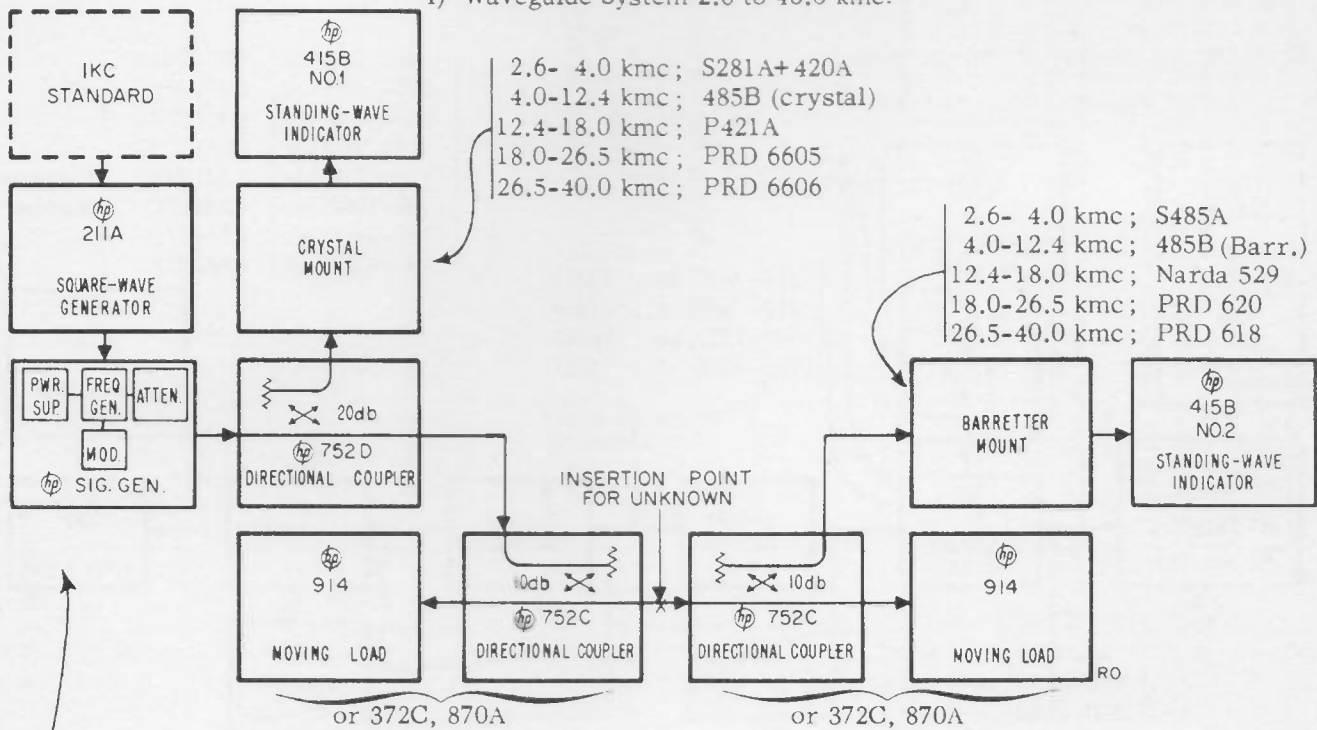

- 2.6- 4.2 kmc ; 616B+S281A
- 3.8- 7.6 kmc ; 618B+ 281A
- 7.0-11.0 kmc ; 620A+ 281A
- 10.0-15.5 kmc ; 626A+M362A+ 292A
- 15.0-21.0 kmc ; 628A+N362A+ 292A
- 20.0-31.0 kmc ; 626A+938A
- 30.0-40.0 kmc ; 628A+940A

Measure impedances looking both ways at insertion point. Adjust 870A's, if used, for swr of 1.05 or less. Set reference reading on 415B No. 2, insert attenuator, read attenuation on 415B No. 2.

Range: 20 to 30 db in one step. Using tuners on each side of the insertion point, approximately 40 db total range with 0 dbm source. 20 db less range with couplers or attenuators.

5) Waveguide Dual Channel System (Alternate):

See Diagram 4 for Signal Generator and Barretter Mount designations.  
See Weinschel Engineering Application Note No. 4 for full discussion.

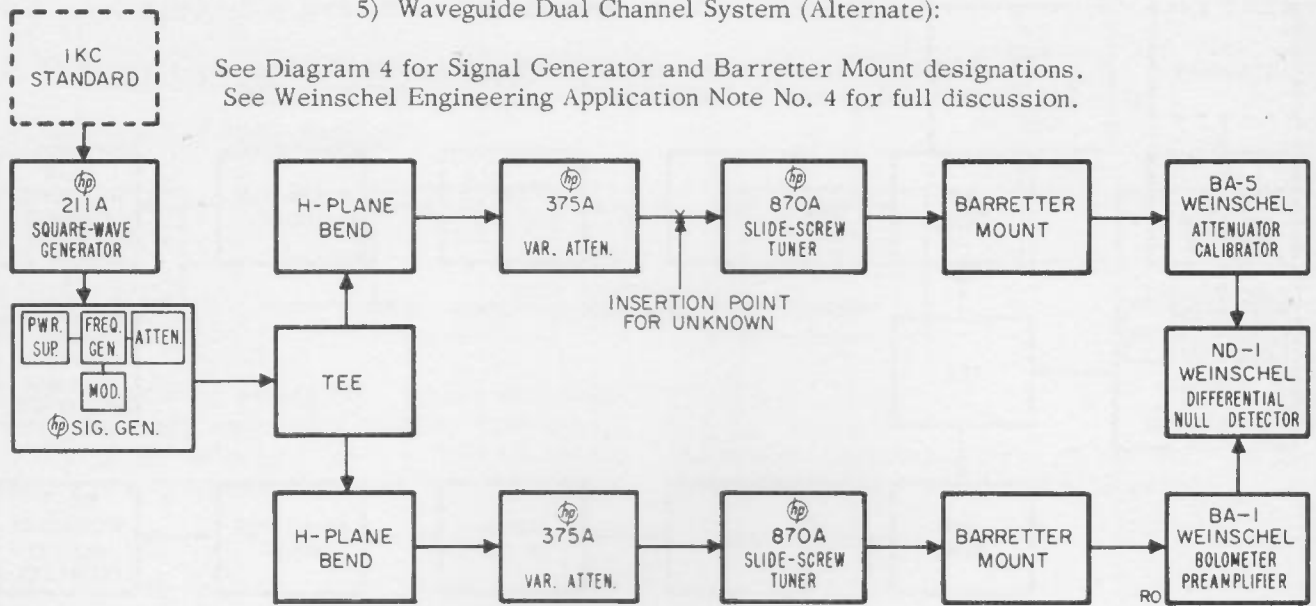

B. LINEAR DETECTION SYSTEMS

1) Coaxial Systems 40 to 4200 mc:

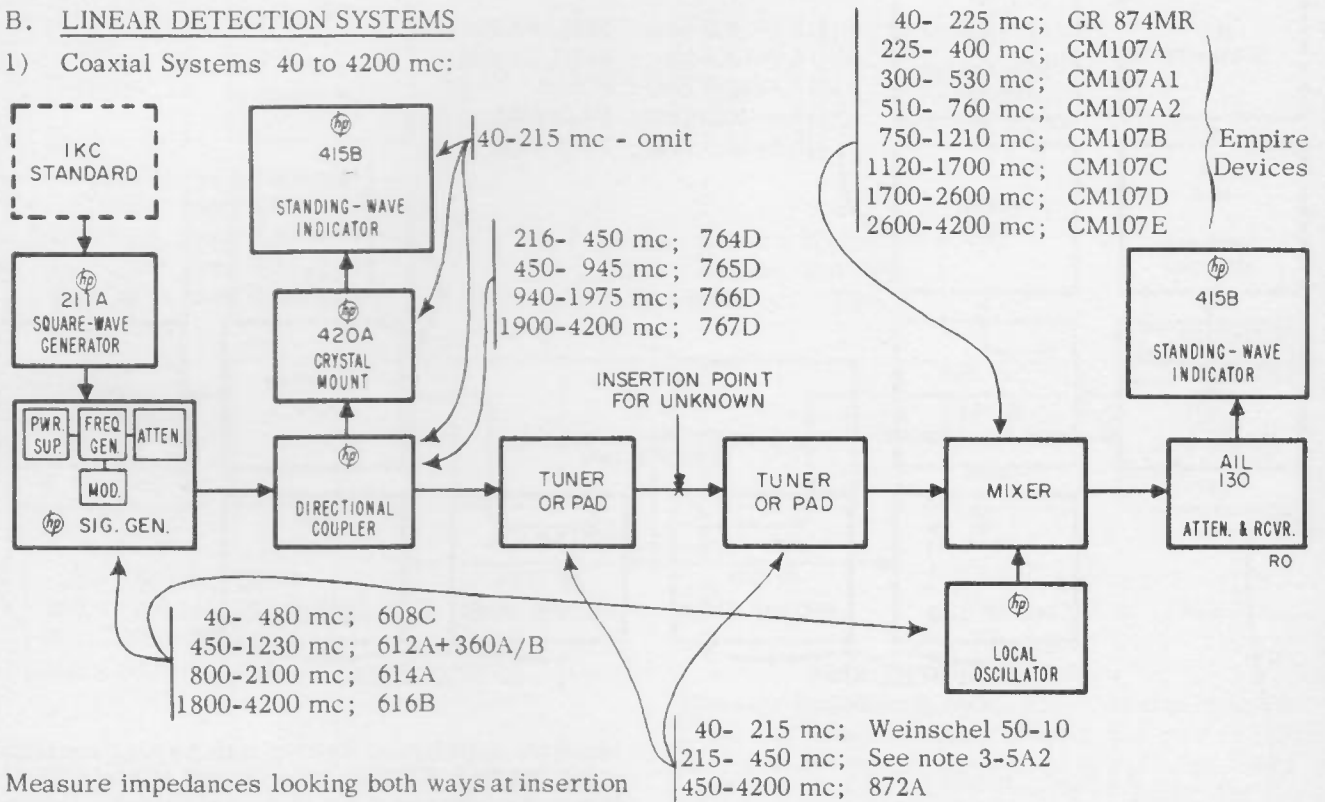

Measure impedances looking both ways at insertion point, and adjust 872A's, if used, for swr of 1.05 or less. Adjust system for convenient readings on 415B and piston attenuator. Insert attenuator under test and readjust piston attenuator to restore 415B reading. Read attenuation as difference between piston readings.

Range: 30 to 50 db in one step. Using tuners, approximately 90 db total with 0 dbm source, 100 db with +10 dbm source, etc. 20 db less range using pads.

2) Waveguide Systems 2.6 to 18.0 kmc:

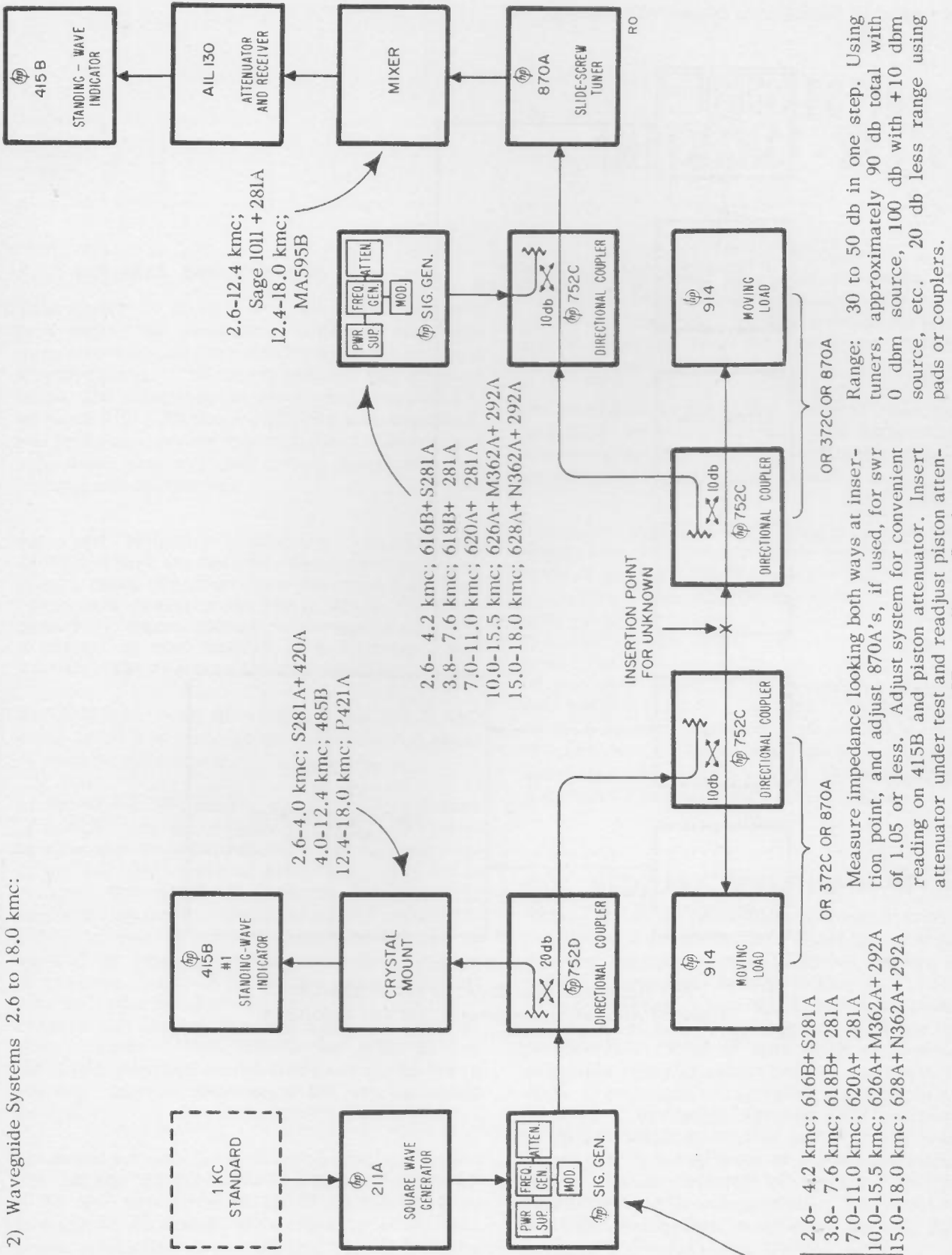

Range: 30 to 50 db in one step. Using tuners, approximately 90 db total with 0 dbm source, 100 db with +10 dbm source, etc. 20 db less range using pads or couplers.

Measure impedance looking both ways at insertion point, and adjust 870A's, if used, for swr of 1.05 or less. Adjust system for convenient reading on 415B and piston attenuator under test and readjust piston attenuator to restore 415B reading. Read attenuation as difference between piston readings.

3) Parallel IF Substitution System (Alternate):

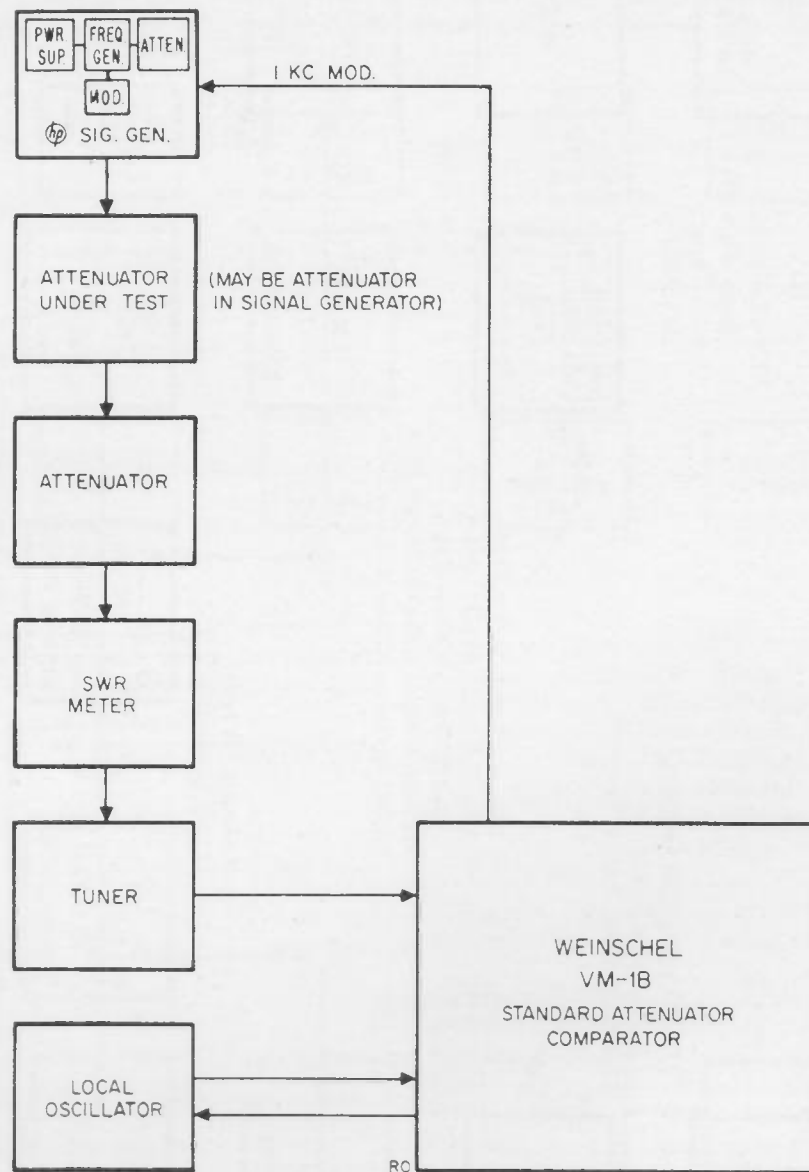

See Weinschel Data Sheet on Model VM-1B  
Standard Attenuator Comparator for full discussion

## SECTION IV IMPEDANCE SYSTEMS

### 4-1 GENERAL DESCRIPTION

This section is divided into two parts. The first part deals with reflection coefficient magnitude measurements and the second discusses impedance measurements. Measurements of the coupling factor and directivity of directional couplers are included with reflection coefficient measurements, and probe square-law detection checks and residual reflection measurements are included with impedance measurements.

Since all reflection coefficient measurements described here are basically attenuation measurements, using the square-law detection technique, ranges are generally limited to 30 db. For high-directivity measurements on waveguide couplers, a crystal is used instead of a barretter, with greater range at somewhat less accuracy.

At frequencies from 50 to 500 mc, the VHF Bridge setup is used to measure the magnitude and phase of unknown impedances.

At the higher frequencies, the slotted-line system is used for impedance measurements. This system is also used to check slotted lines for probe detector law and residual reflection. The probe detector law check is made to determine the limits of square-law operation for the crystal detector, so that departure from square-law may be avoided or accounted for in swr measurements. If greatest accuracy is desired, measurements may be repeated after the two 415B's are interchanged and the readings averaged to cancel out their errors. Data should be taken in both CRYSTAL positions on the 415B, so that the better position may be determined for any individual crystal.

In coaxial systems, slotted line residual reflections are checked by the null shift method. The position of an open circuit on the end of the line is moved in discrete, accurately-known steps by substituting center conductors of varying lengths. At the same

time, the movement of a minimum on the line is accurately measured with the scale and vernier. From the difference in the movements the residual reflection from the end of the slotted line can be found.

In waveguide systems, the residual reflection is generally so small that null shift measurements are not practical. The conventional sliding-load technique is recommended instead.

Impedance measurements using a slotted line are made with an accuracy which depends primarily upon departure from square-law and the residual reflection. The detector can generally be operated within its square-law region or the departure from square-law can be taken into account. However, the residual reflection from the load end of the line cannot be eliminated and will add to the reflection from the load. Ordinarily, the residual is sufficiently small so that no correction is necessary. Corrections can be made for the residual reflection in coaxial systems using the data found in the null-shift measurement.

### 4-2 ACCURACY CONSIDERATIONS

There are many techniques possible in reflection coefficient measurements. Those shown here are recommended as the most practical. In waveguide systems, tuners can be used to establish an almost perfect system. In coaxial systems, however, sliding loads and shorts are not available for all frequencies. Even if they were available, unavoidable residual reflections at connectors would make it impossible to establish a system as accurate as a waveguide system. The accuracy of a given coaxial system is influenced by a great number of factors, many of them interacting, so that a simple statement of accuracy that applies to all systems is not possible. Instead an error formula is supplied, with some typical figures given as a general guide.

Impedance systems accuracies are shown under the various block diagrams.

At this time (June, 1960) very few impedance measurements may be made with an accuracy directly traceable to NBS. Standard mismatches can be calibrated in X-band waveguide, so that if desired such standards could be submitted to NBS and then used to calibrate waveguide slotted lines.

**4-3 IMPEDANCE REFERENCES**

- 1) A. Fong, "Direct Measurement of Impedance in the 50-500 MC Range", Hewlett-Packard Journal, Vol. 1, No. 8, April, 1950.
- 2) W. B. Wholey, "Good Practice in Slotted-Line Measurements", Hewlett-Packard Journal, Vol. 3, Nos. 1 & 2, September and October, 1951.

- 3) J. K. Hunton and W. B. Wholey, "The Perfect Load" and the Null Shift--Aids in SWR Measurements, Hewlett-Packard Journal, Vol. 3, No. 5-6, January-February, 1952.
- 4) H. C. Poulter, "A Note on Measuring Coaxial Coupler Directivity", Hewlett-Packard Journal, Vol. 8, No. 9-10, May-June, 1957.
- 5) G. F. Engen and R. W. Beatty, "Microwave Reflectometer Techniques", IRE Transactions on Microwave Theory and Techniques, Vol. MTT-7, No. 3, July, 1959.

NOTE: In all measurements made in this section, the 211A Square Wave Generator may be used to modulate the source, with a 1 kc sync signal from a frequency standard, as in the attenuation section. It is not specified, however, as the lower accuracies attainable here do not justify it.

**4-4 REFLECTION COEFFICIENT SYSTEM DIAGRAMS**

**A. COAXIAL SYSTEMS -- 215 to 4200 mc**

1) Coupling Factor:

- 215 - 480 mc; 608C
- 450 - 1230 mc; 612A + 360A or B
- 800 - 2100 mc; 614A + 211A
- 1800 - 4200 mc; 616B + 211A

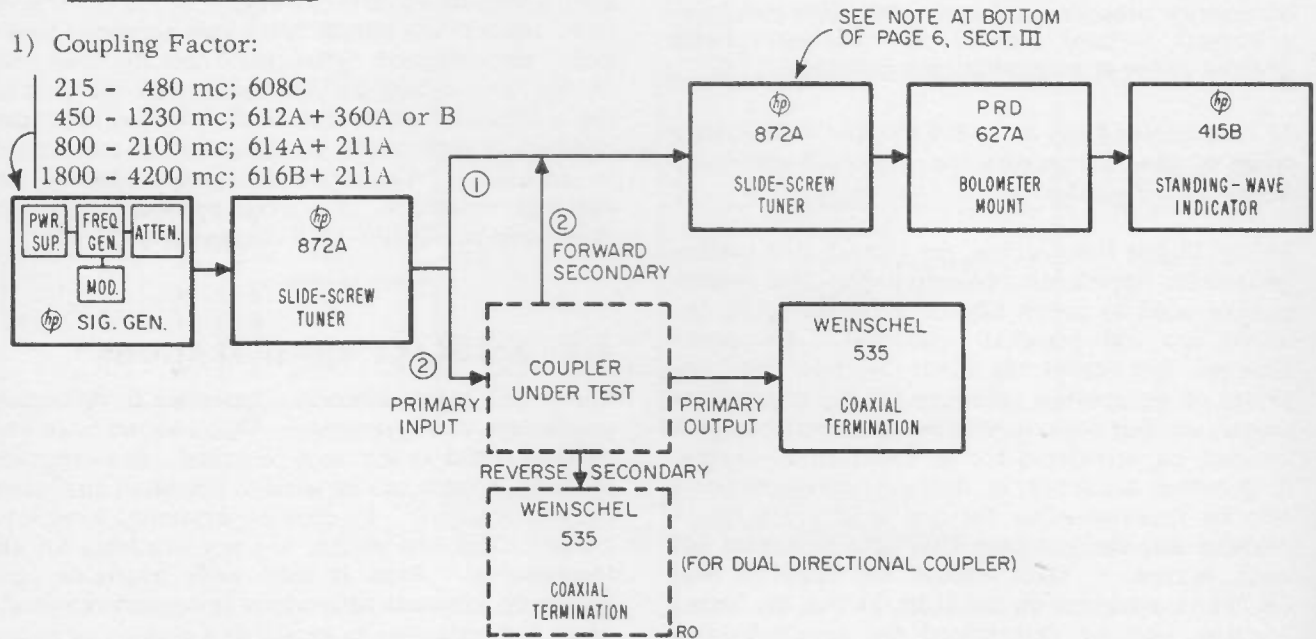

NOTE: From 215 to 450 mc, Weinschel 50-10 pads may be substituted for the 872A's with a possible slight loss in accuracy.

Measure impedances looking into tuners toward generator and PRD 627A and adjust for swr's less

than 1.05. Set reference level on 415B with tuners joined, insert coupler, read coupling factor on 415B.

Range: Approximately 30 db.

Accuracy: Approximately  $\pm .1$  db.

2) Directivity

a. Dual Coupler:

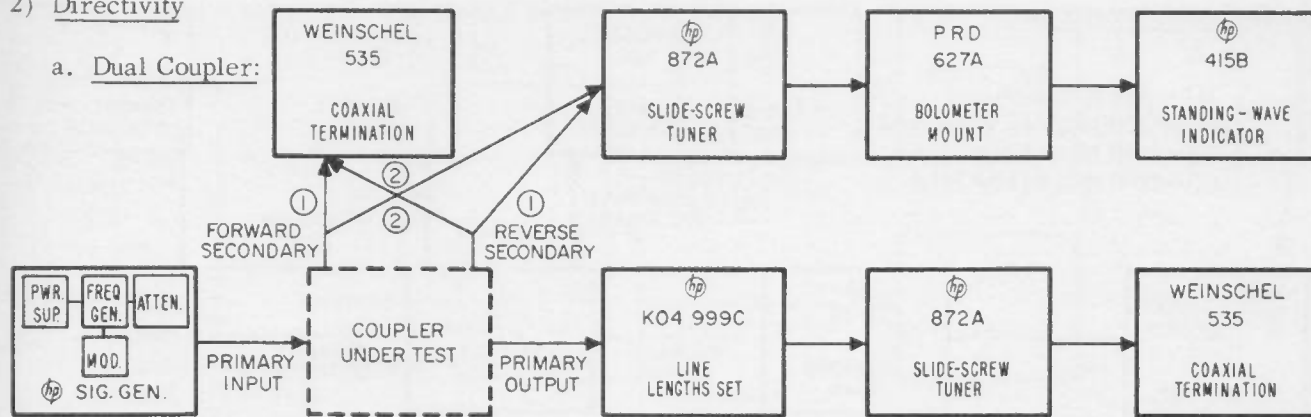

- 215- 480 mc; 608C
- 450-1230 mc; 612A+360A/B
- 800-2100 mc; 614A+211A
- 1800-4200 mc; 616B+211A

Measure impedance looking into 872A toward PRD 627A and adjust to reduce swr to 1.05 or less. See note in paragraph 3-5A2, Coaxial Systems.

1) With basic line length in the systems, adjust the other 872A for a null on 415B. Remove basic line length, insert appropriate length for frequency used, and read 415B.

2) Reverse connections to secondary outputs and read 415B. Calculate directivity from 415B readings, coupling factors, and correction data.

Range: Approximately 30 db with 608C, 27 db with 612A, 20 db with 614A, 616B.  
Accuracy: Depends upon coupling factors, directivity, swr's. Approximately  $\pm .5$  db with tuner on PRD 627A as shown;  $\pm 1.2$  db without tuner.

b. Single Coupler:

- 215- 480 mc; 608C
- 450-1230 mc; 612A+360A/B
- 800-2100 mc; 614A+211A
- 1800-4200 mc; 616B+211A

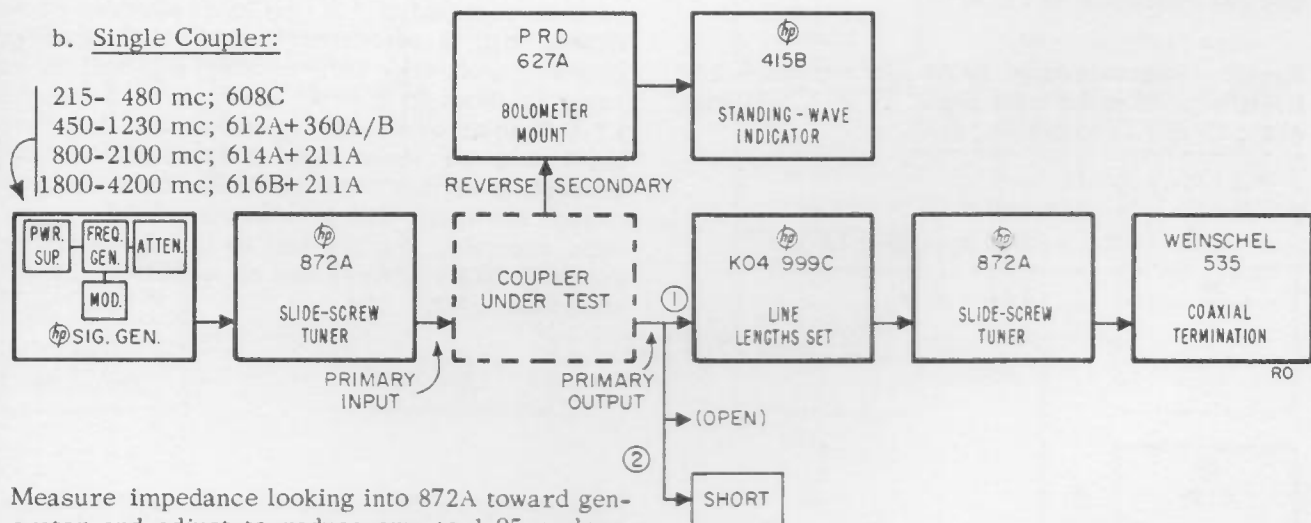

Measure impedance looking into 872A toward generator and adjust to reduce swr to 1.05 or less. See note in paragraph 3-5A2, Coaxial Systems.

1) With basic line length in the system, adjust the other 872A for a null on the 415B. Remove basic line length, insert appropriate length for frequency used, and read 415B.

2) Put open and short on coupler primary arm output and take average of 415B readings.

Calculate directivity from 415B readings and correction data.

Range: Approximately 30 db with 608C, 27 db with 612A, 20 db with 614A, 616B.

Accuracy: Depends upon directivity, swr's. Approximately  $\pm .3$  db with tuner on generator as shown; approximately  $\pm 2$  db without tuner.

3) Reflection Coefficient:

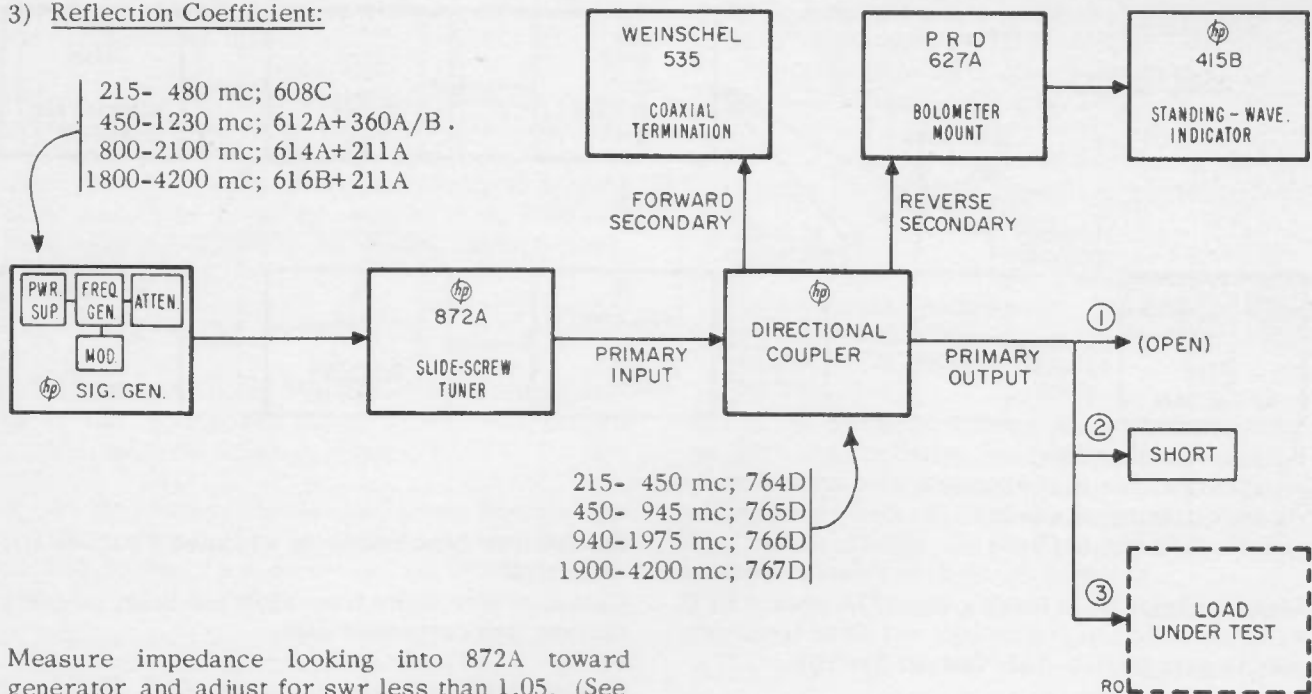

Measure impedance looking into 872A toward generator and adjust for swr less than 1.05. (See note in paragraph 3-5A2, Coaxial Systems.) Connect as shown. Put first open and then short on coupler, noting the 415B readings. Adjust gain so as to make average of readings some convenient reference value. Insert the load and read reflection coefficient on the 415B.

Range: Approximately 30 db (.03 minimum reflection coefficient) with 608C; 27 db (.045) with 612A; 20 db (.1) with 614A, 616B.

Accuracy: Can be evaluated from formula:

$$\rho_m = \frac{[(T - \rho_1 D_r) \rho_L + D_r] (1 - \rho_1^2)}{T(1 - \rho_1 \rho_L)}$$

where T is transmission through coupler (.995 for 20 db coupling),  $\rho_1$  is reflection coefficient at output terminal of coupler,  $D_r$  is directivity of reverse terminal,  $\rho_L$  is true load reflection coefficient,  $\rho_m$  is measured coefficient. In worst possible case, with 767D coupler,  $\rho_m$  will be in error by about .05 when  $\rho_L$  is near zero, and about  $\pm 1.5$  db in error when  $\rho_L$  is near unity. However, there are so many factors involved that the probability of this much error is very low. Generally, the error will be less than half the maximum possible. Errors will be less for the other couplers, down to about half as much for the 764D as for the 767D.

B. WAVEGUIDE SYSTEMS -- 2.6 to 40.0 kmc

1) Coupling Factor:

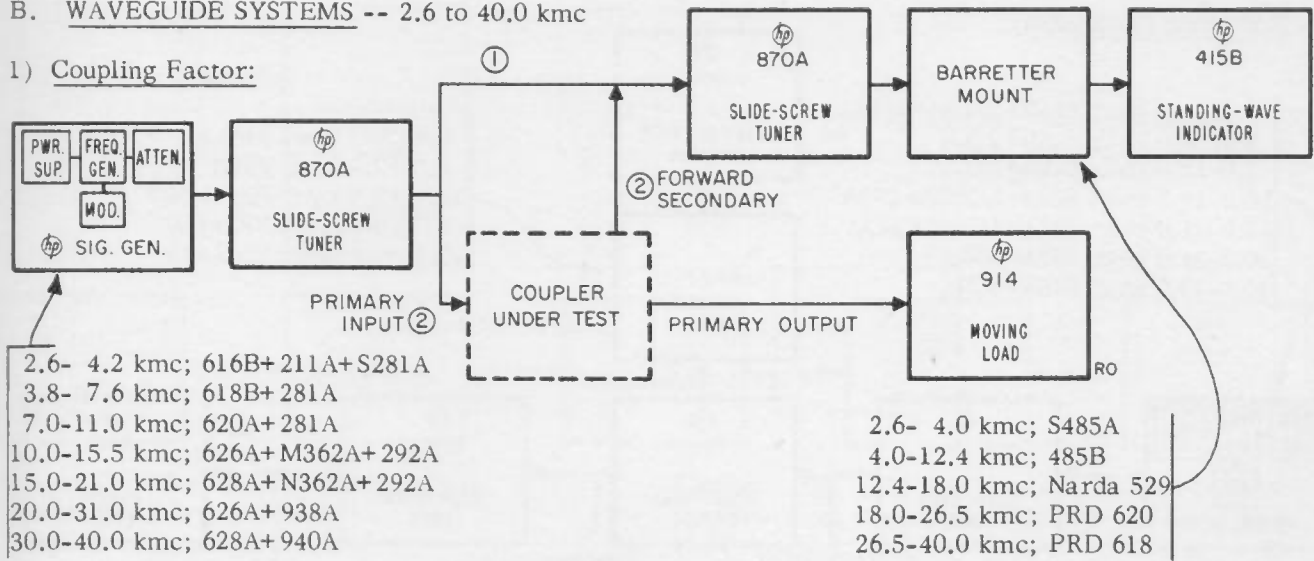

Measure impedances looking into the tuners toward generator and barretter mount and adjust for swr's less than 1.05. Set reference level on 415B with tuners joined, insert coupler, read coupling factor on 415B.

Range: Approximately 30 db.

Accuracy: Approximately  $\pm 1$  db.

2) Directivity:

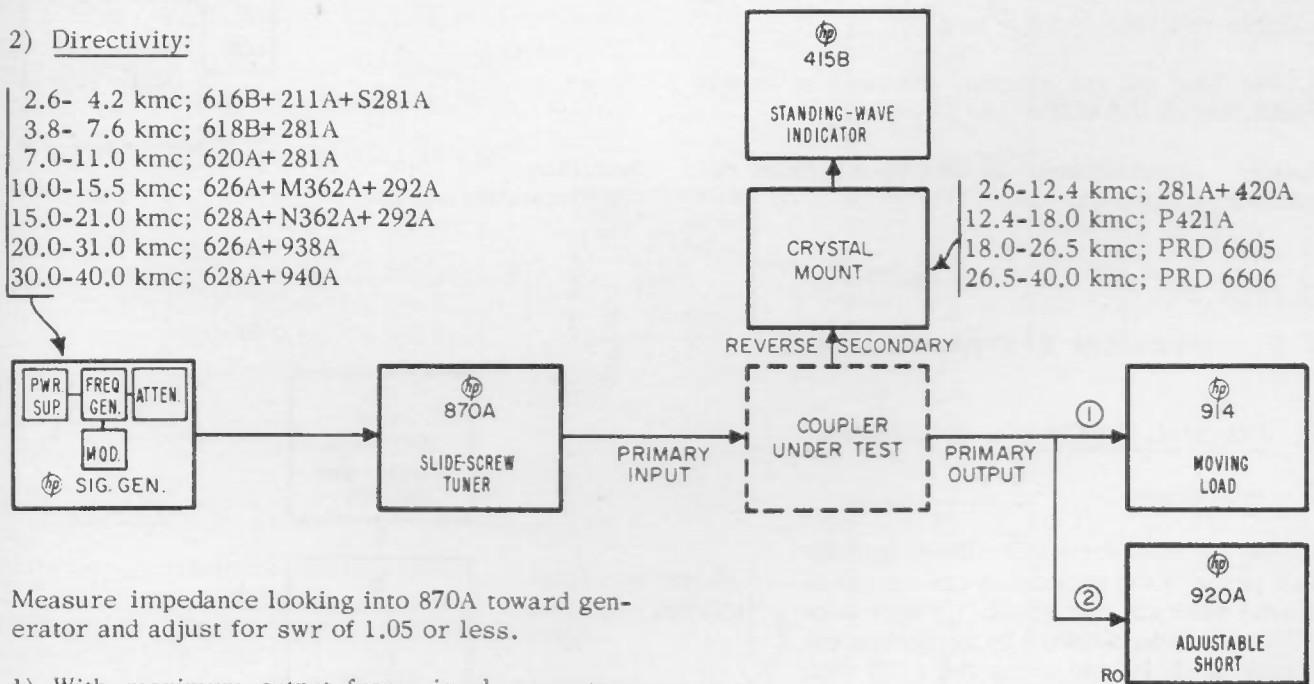

Measure impedance looking into 870A toward generator and adjust for swr of 1.05 or less.

1) With maximum output from signal generator, move 914 load and note maximum and minimum 415B readings. Note generator attenuator setting.

2) Reduce generator level. Remove 914 and install 920A. Move 920A and adjust generator level to get average 415B reading equal to maximum obtained with 914.

From change in generator attenuator reading and 415B readings, calculate directivity.

Range: Approximately 40 db with 20 db coupler and 0 dbm source, 60 db with 10 db coupler and +10 dbm source, etc.

Accuracy: Approximately  $\pm 1$  db.

3) Reflection Coefficient:

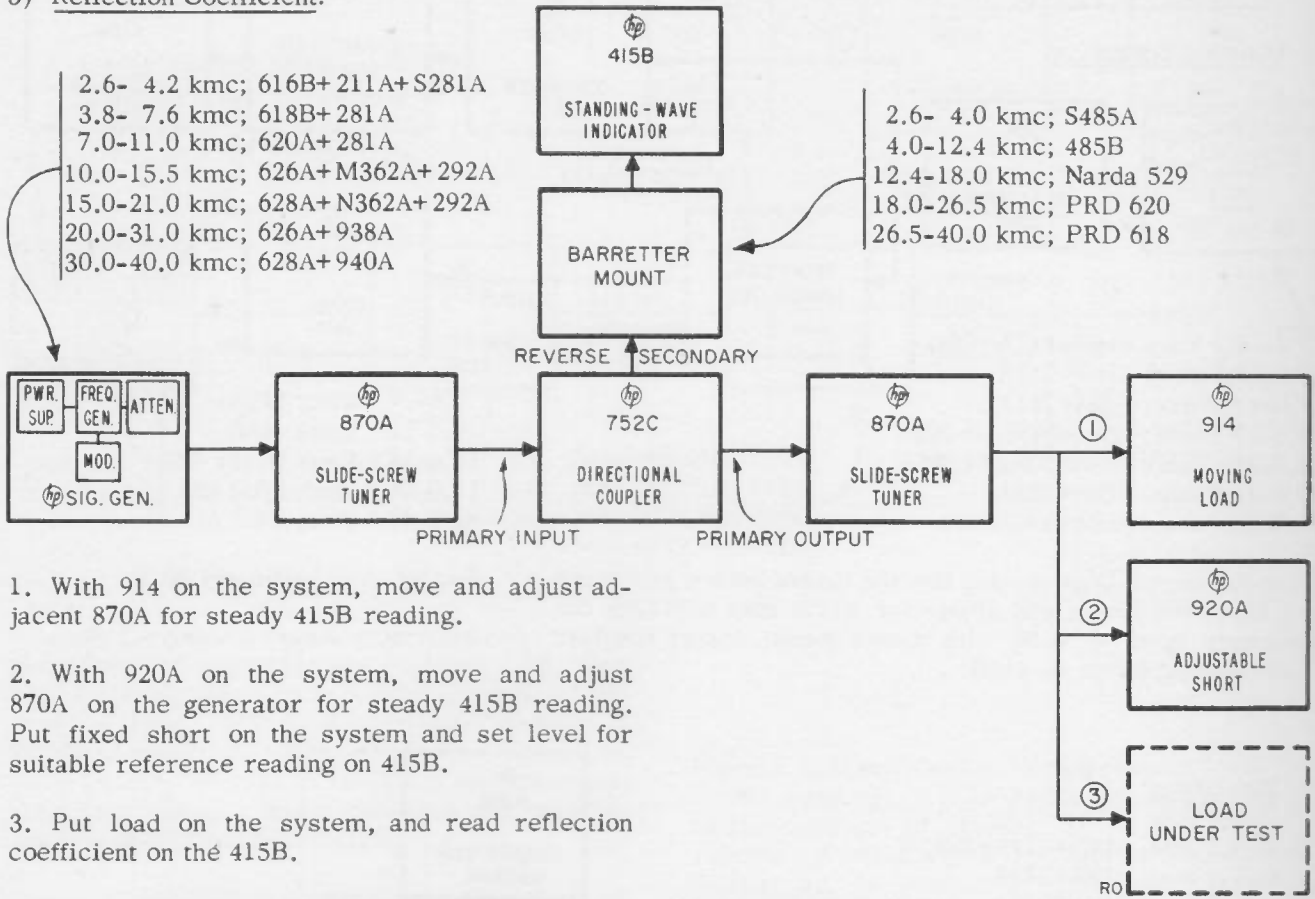

Range: Approximately 30 db (.03 minimum reflection coefficient).

Accuracy: Approximately  $\pm .2$  db.

**4-5 IMPEDANCE SYSTEM DIAGRAMS**

A. COAXIAL SYSTEMS -- 50 to 500 mc

Impedance:

Adjust the 803A for a null. The magnitude and phase of the impedance are then read on the 803A and corrected. Greater sensitivity may be obtained by modulating the signal at 1 kc and using the 415B with the 417A.

Range: 2 to 2000 ohms,  $-90^\circ$  to  $+90^\circ$ .

Accuracy:  $\pm 2\%$  in magnitude,  $\pm 1.2^\circ$  in phase (corrected).

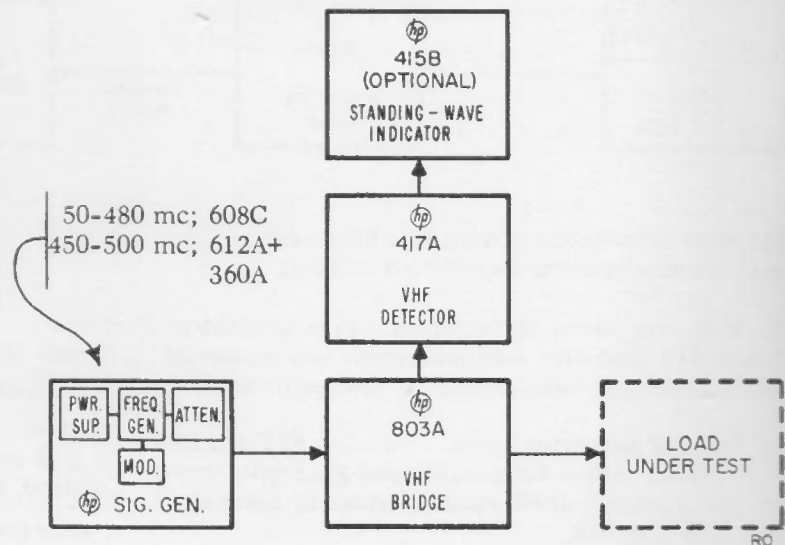

B. COAXIAL SYSTEMS -- 500 to 4200 mc

1) Probe Detector Law:

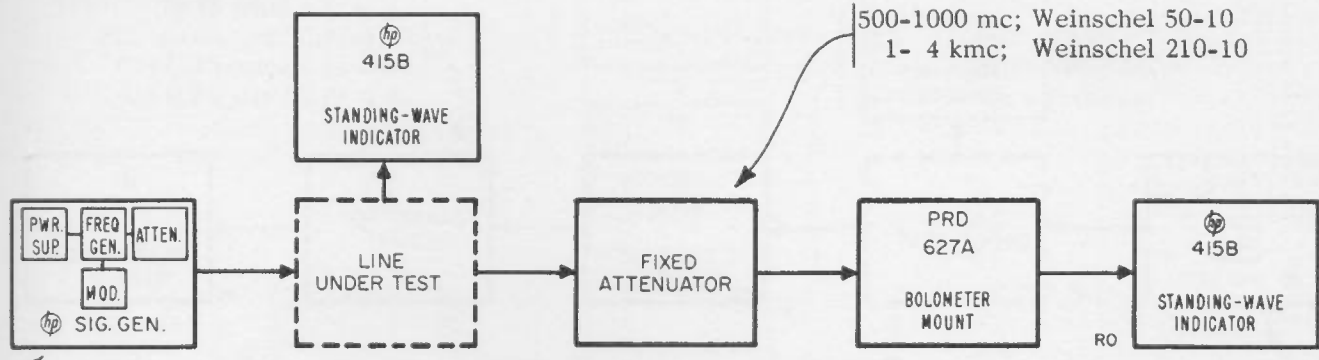

500-1000 mc; Weinschel 50-10  
1- 4 kmc; Weinschel 210-10

500-1230 mc; 612A+360A/B  
800-2100 mc; 614A+211A  
1800-4200 mc; 616B+211A

Compare the 415B readings to determine the departure from square law of the probe detector on the line under test.

Range: 30 db

Accuracy:  $\pm .1$  db (interchange 415B's and average results to cancel 415B errors).

2) Residual Reflection:

Use null-shift technique to measure the residual reflection from end of line.

Accuracy: Approximately  $\pm .01$  in swr.

500-1230 mc; 612A+360A/B  
800-2100 mc; 614A+211A  
1800-4200 mc; 616B+211A

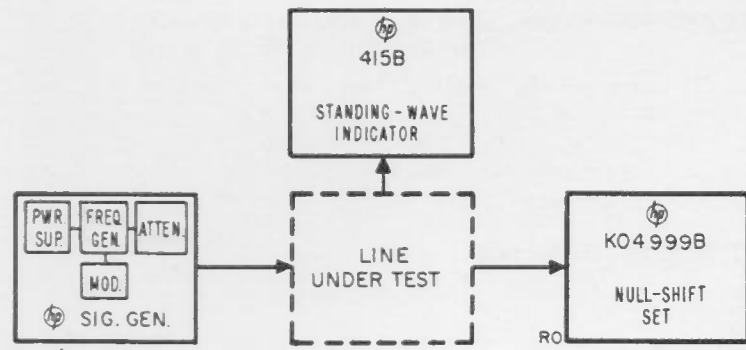

3) Impedance:

Make swr and minimum position measurements, apply corrections to obtain impedance. Use the double-minimum method for large swr's.

Accuracy: Depends on swr. Approximately  $\pm .01$  in swr attainable for low swr's.

500-1230 mc; 612A+360A/B  
800-2100 mc; 614A+211A  
1800-4200 mc; 616B+211A

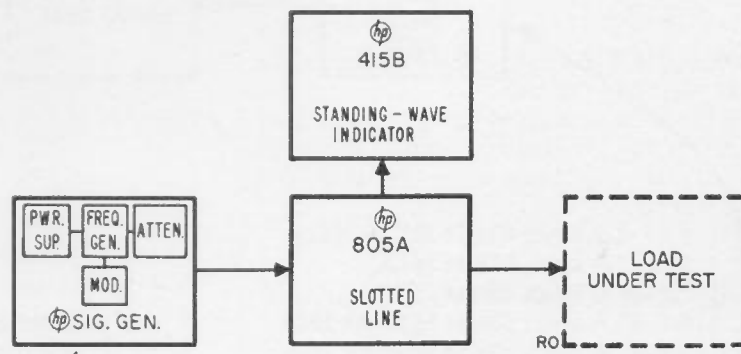

C. WAVEGUIDE SYSTEMS -- 2.6 to 40.0 kmc

1) Probe Detector  
Law:

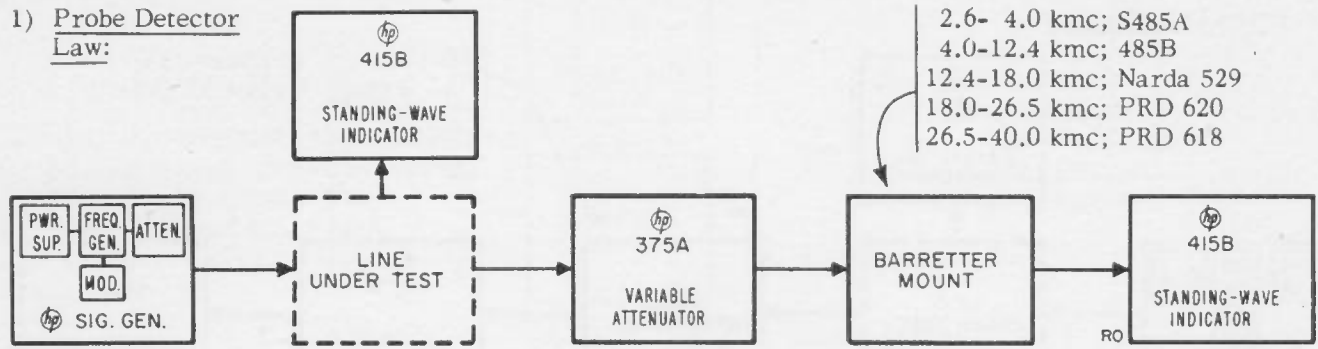

- 2.6- 4.2 kmc; 616B+211A+S281A
- 3.8- 7.6 kmc; 618B+281A
- 7.0-11.0 kmc; 620A+281A
- 10.0-15.5 kmc; 626A+M362A+292A
- 15.0-21.0 kmc; 628A+N362A+292A
- 20.0-31.0 kmc; 626A+938A
- 30.0-40.0 kmc; 628A+940A

Compare the 415B readings to determine the departure from square law of the probe detector on the line under test.

Range: 30 db.

Accuracy:  $\pm 1$  db (interchange 415B's and average results to cancel 415B errors).

2) Residual Reflection:

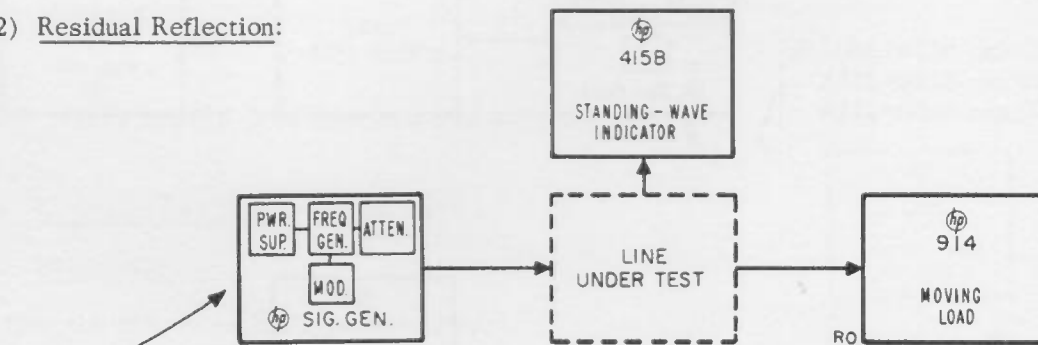

- 2.6- 4.2 kmc; 616B+211A+S281A
- 3.8- 7.6 kmc; 618B+281A
- 7.0-11.0 kmc; 620A+281A
- 10.0-15.5 kmc; 626A+M362A+292A
- 15.0-21.0 kmc; 628A+N362A+292A
- 20.0-31.0 kmc; 626A+938A
- 30.0-40.0 kmc; 628A+940A

Use sliding-load technique to measure residual reflection from the end of the line.

Accuracy: Approximately  $\pm .001$  in swr.

3) Impedance:

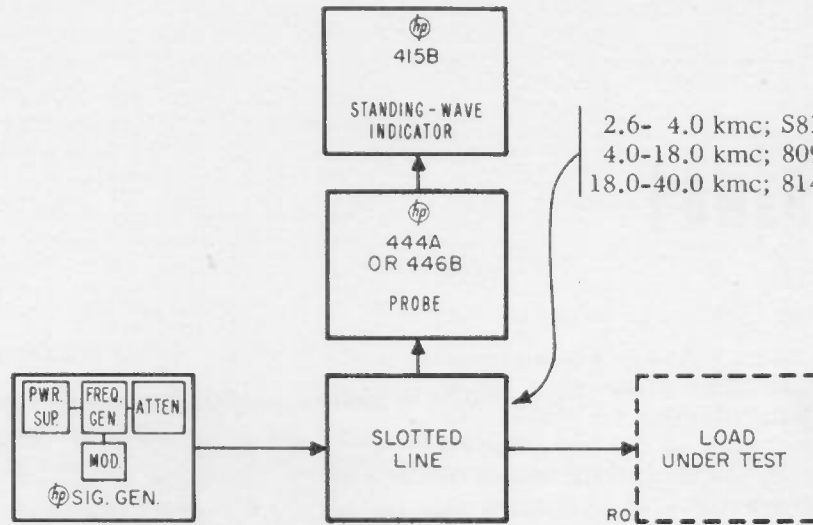

2.6- 4.0 kmc; S810A  
 4.0-18.0 kmc; 809B+ 810B  
 18.0-40.0 kmc; 814B+ 815B

2.6- 4.2 kmc; 616B+ 211A+ S281A  
 3.8- 7.6 kmc; 618B+ 281A  
 7.0-11.0 kmc; 620A+ 281A  
 10.0-15.5 kmc; 626A+ M362A+ 292A  
 15.0-21.0 kmc; 628A+ N362A+ 292A  
 20.0-31.0 kmc; 626A+ 938A  
 30.0-40.0 kmc; 628A+ 940A

Make swr and minimum position measurements to obtain impedance. Use double-minimum for large swr's.

Accuracy: Depends on swr. Approximately  $\pm .01$  in swr attainable for low swr's.

FORMULA FOR ERROR  
IN DC MEASUREMENT:

$$E = \pm 2d \left[ \frac{2P_T}{P} - 1 \right]$$

E = Error in measured power.  
d = Error in dc voltage or current.  
P<sub>T</sub> = Total bolometer power.  
P = Power being measured.

TOTAL POWER REQUIREMENTS FOR BOLOMETERS IN COMMON USE

1. Low power barretters such as the PRD 627A; about 4mw.
2. Double thermistor mounts such as the 477B; about 30mw.
3. Single thermistors such as the 487 series and other barretters such as the Sperry 821 used in 485's; in the range 12-16mw.

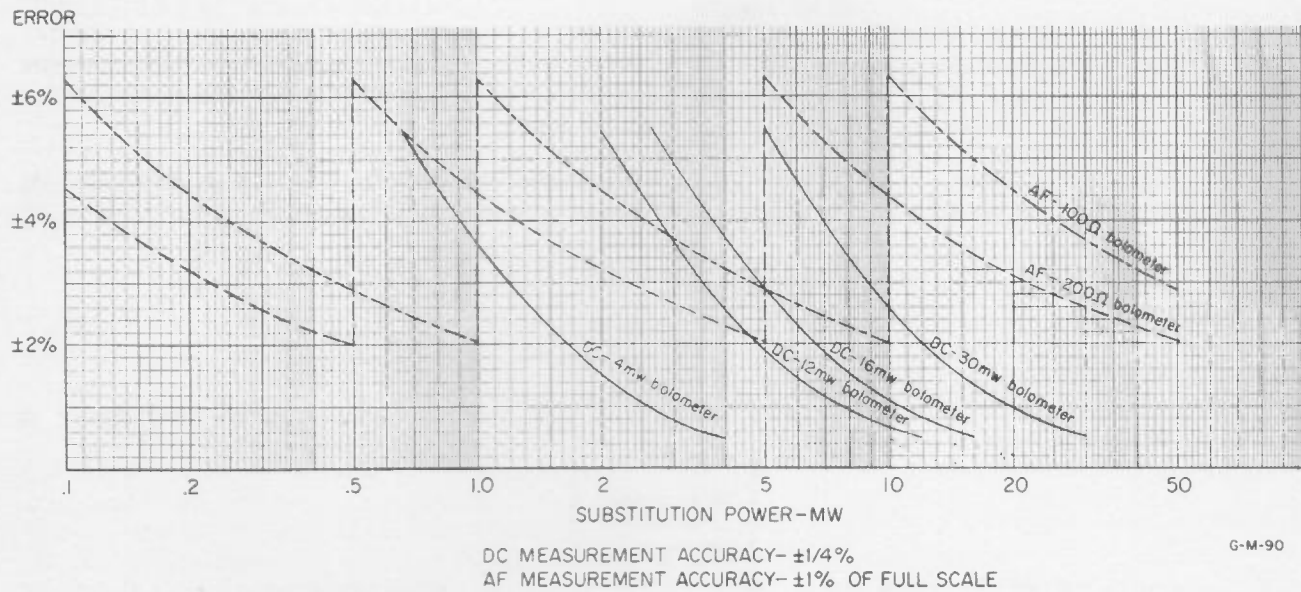

Figure 5-1. Typical Possible Errors in Measurement of Substitution Power

## SECTION V POWER SYSTEMS

### 5-1 GENERAL DESCRIPTION

Measurement systems for power include a manually balanced bolometer bridge for low power levels and a calorimetric power meter for higher levels. Peak power measurement techniques are discussed in paragraph 5-3. The measurement of bolometer mount efficiency is included with the system diagrams, but the required components are not included in the appendix. Most of them will already be on hand for other measurements, but the variable resistance bridge must be constructed. More complete information on the technique is included in paragraph 5-4, Power References 1 and 2; and in paragraph 1-5, General References 1.

The manually balanced bolometer bridge is used to measure power up to about 25 milliwatts in coaxial systems and to about 12 milliwatts in waveguide systems. At levels which are low compared to the total power required by the bolometer, audio power is substituted for rf power, with constant dc power used for bias and balance indication. At higher levels dc only is used, varied for balance with and without rf power applied.

In the measurement of the substitution power, although dc power can be measured with greater accuracy than af power, the net error is increased when differences are taken, as in the all-dc measurement. Consequently, the accuracy varies according to the total bolometer power and the rf power being measured. As the rf level is decreased, the error increases. The point at which greater accuracy is attainable with af substitution depends upon the accuracy with which the af can be measured.

Figure 5-1 gives some typical accuracy curves for various bolometers, based on the measurement of dc voltage or current at any level to  $\pm 1/4\%$ , and the measurement of af voltage with a 400H,

accurate to  $\pm 1\%$  at full scale. Below about 1 milliwatt, temperature drift will make the indicated accuracies increasingly difficult to attain. The dc formula used is shown on Figure 5-1, so that it can be applied for any particular case. All that is necessary to apply the formula is to change the scale of the vertical axis.

DC instrumentation is not specified, as laboratories acquiring microwave standards are in general already equipped with adequate dc equipment. The range of dc to be measured is approximately 4 to 30 ma (bridge current) or .4 to 2.5 volts (bolometer voltage). The galvanometer should have a sensitivity of about .1 microampere per division or better.

If desired, a Weinschel Model PB-1 Precision RF Power Bridge or Model TB-2 Precision 1 Milliwatt Thermistor Bridge may be substituted for the K04 999A. These bridges are capable of  $\pm .25\%$  and  $\pm .1\%$  accuracy, respectively, in the measurement of the substituted power. The PB-1 requires external dc measurement equipment, while the TB-2 is completely self-contained. The TB-2 measures power very accurately at the 1 milliwatt level by means of a bolometer mount calibrated by NBS, and is intended basically to calibrate signal generator output.

The calorimetric power meter is used for powers from 10 milliwatts to 10 watts. This instrument may be used directly with an error less than  $\pm 5\%$ . With appropriate techniques the error may be reduced even more. To obtain greater accuracy, dc instruments are used to check the calibration at dc, a tuner is used to eliminate mismatch losses, and an efficiency correction is added to the reading. The dc calibration of the 434A may be carried out with an K01 434A or with a dc source and instruments capable of measuring up to 10 watts into 50 ohms.

## 5-2 ACCURACY CONSIDERATIONS

In general there are three sources of error in a microwave power measurement in addition to the error in measurement of the substitution power. They are mismatch loss, rf loss, and substitution error.

Mismatch loss may be evaluated by using Figures 3-1 and 3-2, but in general it can be stated only as lying between two limits. If it is eliminated by using a tuner to tune the load to the line or for maximum power transfer, the tuner loss itself must be evaluated.

Substitution error results from the fact that different amounts of microwave and low-frequency power may be required to produce the same effect on the resistance of a bolometer. Various investigations have shown that up to the X-band region the error is probably less than 1% for the bolometers commonly used.

RF loss occurs in transmission line sections, dielectrics, contacts, etc., and causes the efficiency of all bolometer mounts and most calorimeters to be less than 100%. The efficiency of a mount is difficult to measure accurately, although a technique applying only to barretters has been developed by NBS. A system employing this technique is shown in a block diagram, paragraph 5-5C.

A useful service is offered by NBS (only in X-band) to aid in making accurate microwave power measurements. A power standard consisting of a directional coupler with a bolometer mount on the secondary arm may be submitted for determination of its "calibration factor". This is the ratio between the substitution power in the mount and the microwave power incident upon a perfect termination on the primary arm. It thus includes coupling factor, mount efficiency, substitution error, and mismatch loss all in one factor. Such a device may be used with the power measurement system shown here to establish a known microwave power level to calibrate a second mount, which in turn is used to measure an unknown power. If the substitution power is measured with NBS calibrated dc or ac equipment, the whole measurement accuracy is traceable to NBS. The calibration of the second mount includes substitution error as well as mount efficiency, and is referred to by NBS as the "calibration factor" of the mount. Calibration factors on individual mounts are available from NBS as well as on mount-coupler combinations, both to 1% accuracy.

For calorimetric measurements with the 434A Power Meter, only the measurement of dc calibrating power is traceable to NBS. Substitution error is negligible, but mount efficiency and mismatch loss must be taken into account.

## 5-3 PEAK POWER MEASUREMENT TECHNIQUES

Several possible techniques for the measurement of peak power are discussed below as a general guide. In all cases, attenuators or directional couplers may be required to reduce the signal level before measurement. The attenuation introduced must be measured accurately and taken into account. Further, careful attention must be paid to mismatch considerations throughout the system.

### A. AVERAGE POWER-DUTY CYCLE Technique

Peak power may be calculated from average power, pulse width, and repetition rate. This is the simplest and most common technique, but it gives only the average height of the pulse, and may be inaccurate if pulse width is difficult to measure accurately. It cannot be applied where the average power is below the range that can be measured with bolometers.

### B. NOTCH WATTMETER Technique

The rf pulse is detected with a crystal and presented on an oscilloscope. The output of a signal generator is also fed into the crystal. If the generator can be pulsed off and the notch thus formed positioned to coincide with the unknown pulse, the signal generator level can be adjusted in magnitude to match the notch to the pulse. If the pulse is uneven, the notch may be adjusted to match any point desired. Since they are equal, a measurement of the generator power gives the pulse power. This system works for peak powers within the range of bolometers, so is considerably more sensitive than technique A above. A drawback is that some signal generators cannot be pulsed off.

### C. CW-PULSE COMPARISON Technique

This is a simplification of Technique B. The setup is the same, without the notch. The pulse power and cw power from the generator add in random phase, giving rise to a filled-in pulse above and below the cw line on the oscilloscope. Since there is no base line corresponding to

the cw, the cw cannot be adjusted to equal the pulse. However, if the adjustment is made so that the pulse appears with its bottom edge in line with the cw line, this corresponds to peak power equal to twice cw power, or 6 db higher, so that again the pulse power may be found from a measurement of the cw. This system may suffer from interaction between the two sources, as they are both on at the same time, and is 6 db less sensitive than Technique B.

D. BARRETTTER INTEGRATION-DIFFERENTIATION Technique. This system relies on the time constant of a barretter to integrate the pulse. The resulting audio signal is amplified and then differentiated to give the original pulse shape, which can then be examined and measured with audio techniques. This technique is used by the Sperry Model 630 Peak Power Meter. An excellent discussion of this and other techniques is contained in reference 3, paragraph 5-4.

**5-4 POWER REFERENCES**

- 1) D.M. Kerns, "Determination of Efficiency of Microwave Bolometer Mounts from Impedance Data", Journal of Research, NBS, Vol. 42, No. 6, June, 1949.
- 2) R.W. Beatty and F. Reggia, "An Improved Method of Measuring Efficiencies of UHF and Microwave Bolometer Mounts", Journal of Research, NBS, Vol. 54, No. 6, June, 1955.
- 3) Sperry Gyroscope Company, Application Bulletin 60-70-AB1.
- 4) "Use of the 'Notch Wattmeter' with  $\Phi$  Signal Generators". Hewlett-Packard Journal, Vol.7, No. 4, December, 1955.

**5-5 POWER SYSTEM DIAGRAMS**

A. BOLOMETRIC MEASUREMENT

1) Coaxial System -- 10 to 4000 mc:

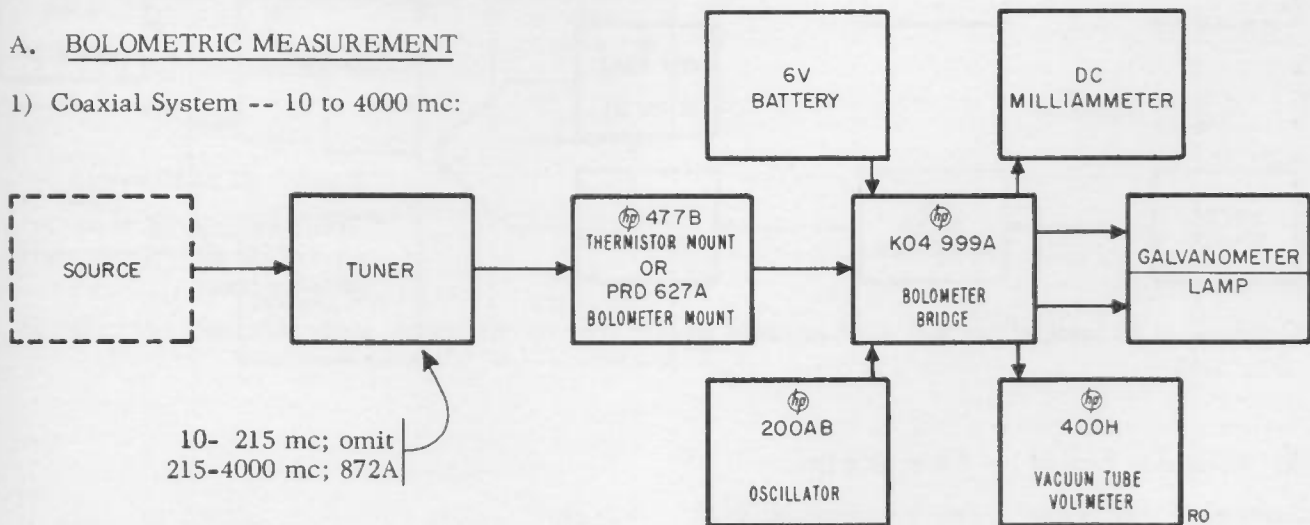

10- 215 mc; omit  
215-4000 mc; 872A

NOTE

If an 872A is used in the range 215 to 450 mc to reduce the errors, it may be necessary to use the 1/4 wavelength line supplied with the KO4 999C to extend the tuning range down to 215 mc.

\*\*\*

Measure power with the PRD 627A using af substitution from .1 to .7 mw and dc substitution from .7 to 3 mw. Measure power with the 477B using

af substitution from 3 to 5 mw and dc substitution from 5 to 25 mw.

Range: 10 to 500 mc -- 1 to 25 mw.  
500 to 4000 mc -- .1 to 25 mw.

Accuracy: See Figure 5-1. Overall accuracy figures should include mount efficiency and tuner loss, both of which may or may not be significant.

2) Waveguide System -- 2.6 to 40.0 kmc:

Measure power with the 487B or S485A using af substitution from .1 to 5 mw and dc substitution from 5 to 12 mw.

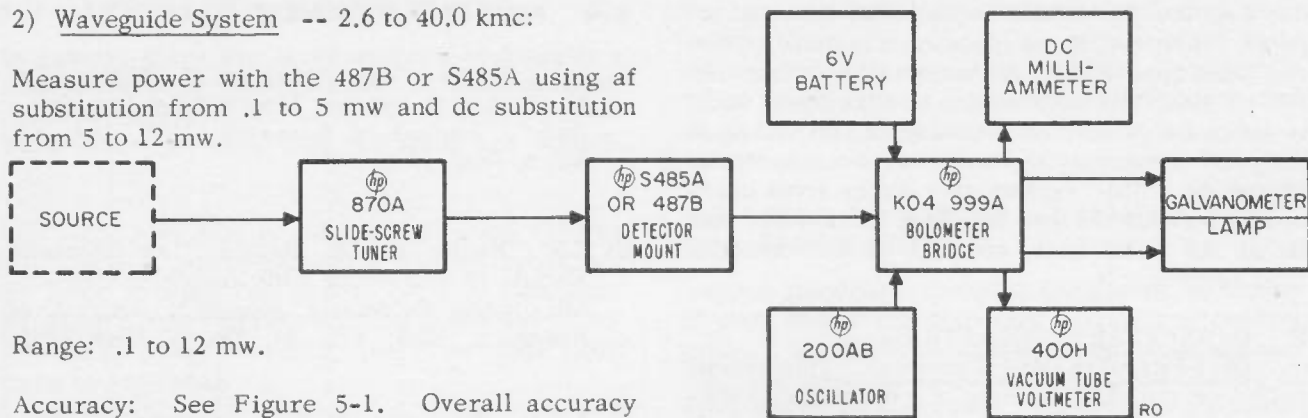

Range: .1 to 12 mw.

Accuracy: See Figure 5-1. Overall accuracy figures should include mount efficiency and tuner loss both of which may or may not be significant.

B. CALORIMETRIC MEASUREMENT

1) Coaxial System -- dc to 4000 mc:

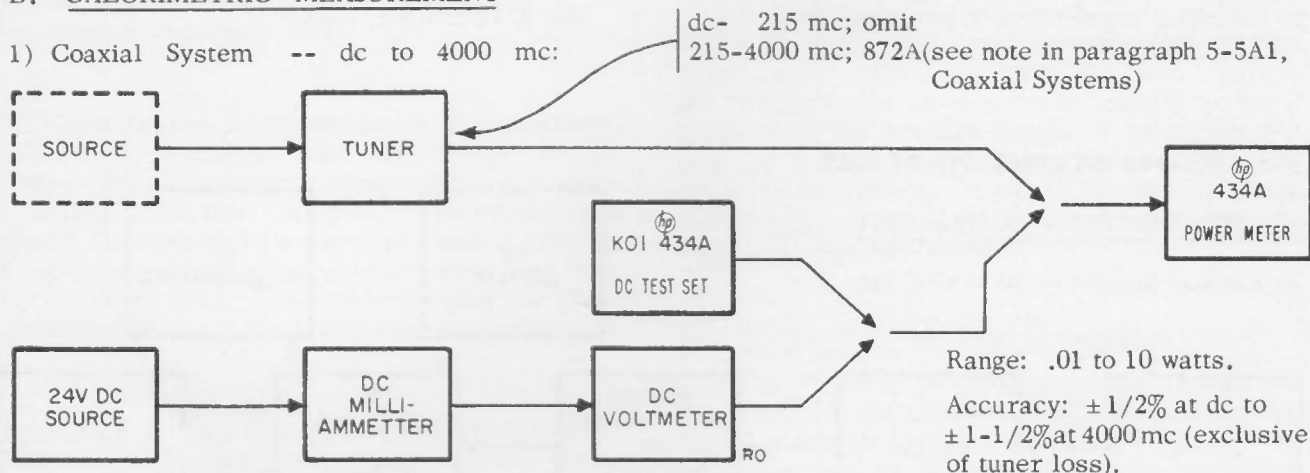

Range: .01 to 10 watts.

Accuracy:  $\pm 1/2\%$  at dc to  $\pm 1-1/2\%$  at 4000 mc (exclusive of tuner loss).

Calibrate at dc using either K01 434A or other source, tune out mismatch, apply efficiency corrections.

2) Waveguide System -- 2.6 to 12.4 kmc;

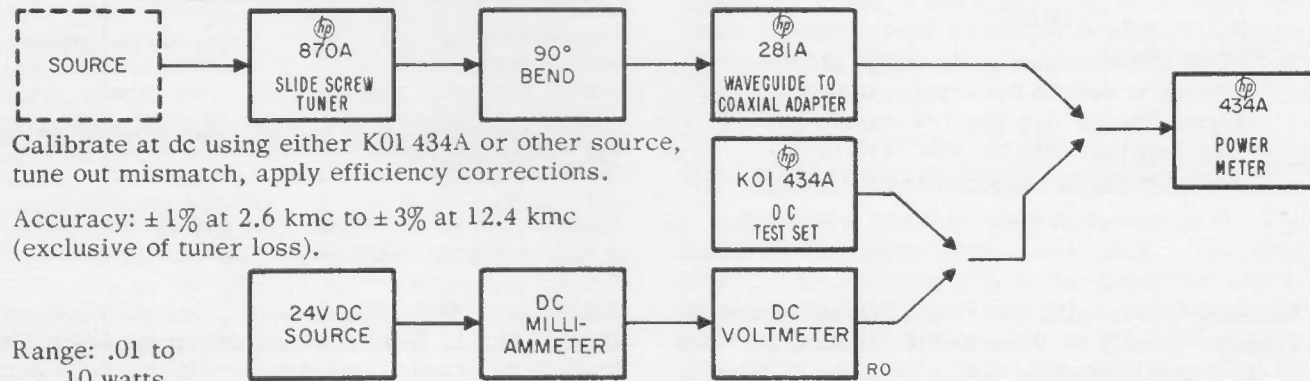

Calibrate at dc using either K01 434A or other source, tune out mismatch, apply efficiency corrections.

Accuracy:  $\pm 1\%$  at 2.6 kmc to  $\pm 3\%$  at 12.4 kmc (exclusive of tuner loss).

Range: .01 to 10 watts.

C. BARRETTTER MOUNT EFFICIENCY MEASUREMENT

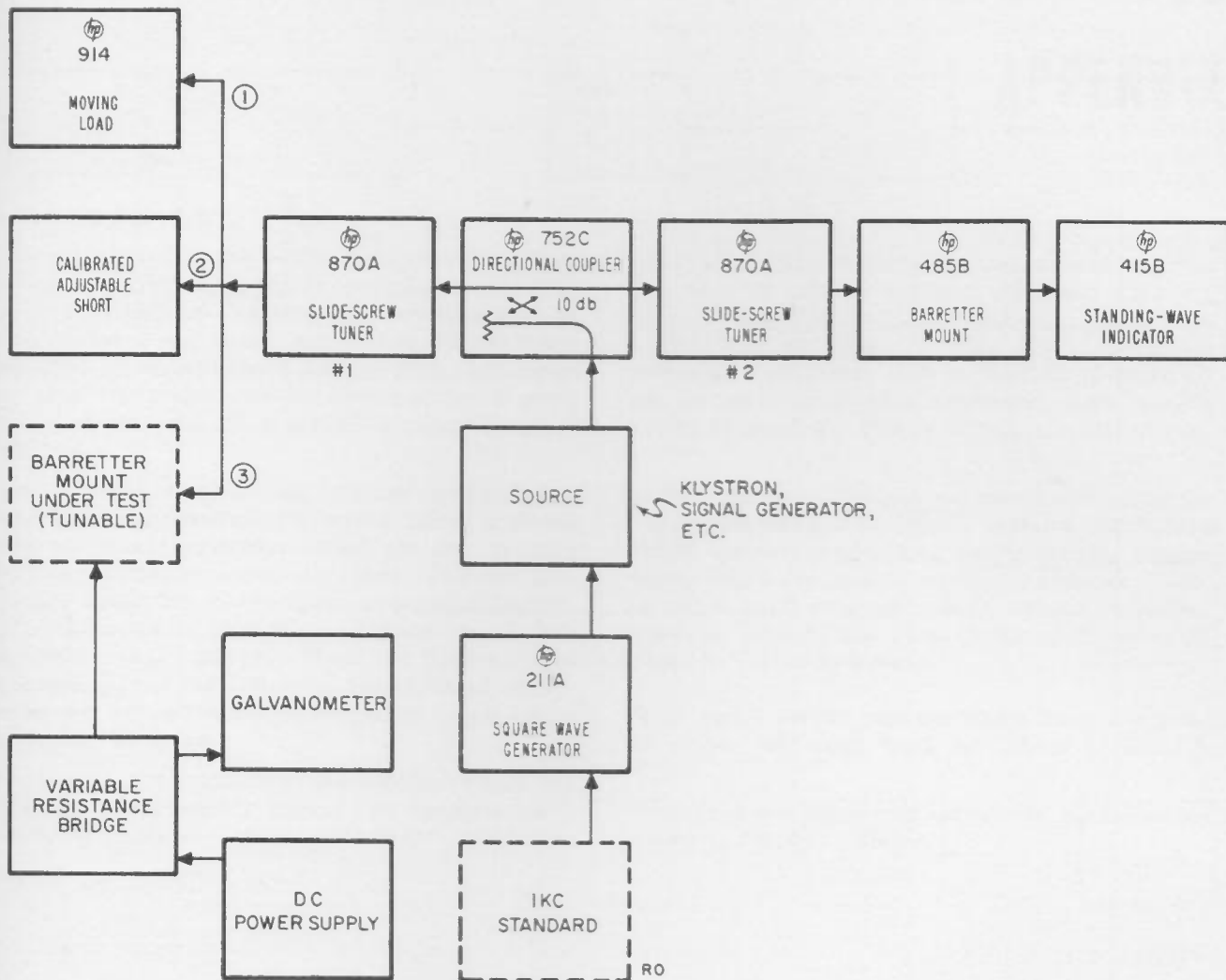

1) Tune out coupler directivity signal. With 914 on line, adjust 870A #1 for steady reading on 415B as 914 is moved.

2) Tune detector and set reference level. With calibrated adjustable short on line, adjust 870A #2 for steady reading (less than about 1.5 db variation) on 415B as short is moved. Set short to give average reading on 415B if steady reading not achieved. Set level for full-scale reading on 20 db range of 415B with maximum gain. Switch to EXPAND and 30 db range, adjust gain for full-scale reading.

3) Tune barretter mount under test. With mount on line, adjust its tuner for null on 415B while variable resistance bridge is balanced at 200 ohms.

4) Measure reflection coefficient. Change resistance of bolometer by means of bridge. Balance at values of about 160 and 240 ohms and read 415B. Readings should be near full-scale on 50 db range.

Calculate mount efficiency, applying corrections for 415B readings and short efficiency.

See General Reference 1, paragraph 1-5, for more detail.

1. The first part of the document discusses the importance of maintaining accurate records.

2. It is essential to ensure that all data is entered correctly and consistently.

3. The following table provides a summary of the key findings from the study.

4. The results indicate a significant correlation between the variables studied.

5. Further research is needed to explore the underlying mechanisms of this relationship.

6. The data suggests that there are several factors that influence the outcome.

7. It is important to consider these factors when interpreting the results.

8. The study has provided valuable insights into the complex nature of the phenomenon.

9. These findings have important implications for the field of research.

10. The authors would like to thank the funding agency for their support.

# APPENDIX

## INTRODUCTION

The appendix lists compatible equipment for measurement of frequency, power, impedance and attenuation. In addition to ordering information such as manufacturer and price, the equipment list gives the type of measurement and the frequency range so that equipment can be specified for a given measurement and for a given frequency range if desired.

For example, the heading, Instrument Quantities, (see next page) is divided first into coaxial systems and waveguide systems. Each system category is then divided by frequency range and under frequency range the measurement categories appear. (F) designates frequency, (A) attenuation, (I) impedance and (P) power. Thus, the first vertical column (F) on the left lists quantities of equipment for measurement of frequency below 1 kmc in coaxial systems.

Horizontal rows indicate the measurements for which a given unit is used. For example, an  $\Phi$  Model 616B Signal Generator, is used in frequency,

attenuation, and impedance measurements from 2-4 kmc in coaxial systems and from 2.6 - 4.0 kmc (S band) in waveguide systems. Thus, two 616B's are sufficient to make any measurement required. However, if it is desired to make all six measurements simultaneously, eight 616B's would be needed. Prices shown are unit prices.

Table 1 shows electronic type instrument quantities used in coaxial and waveguide systems and Table 2 shows quantities of actual waveguide type instruments which are used in waveguide systems. Thus, to order equipment for coaxial systems consider items in Tables 1 and 3 and for waveguide systems items in Tables 1, 2 and 3.

Since price varies with waveguide band, the price is shown for each band in Tables 1, 2 and 3.

Miscellaneous equipment useful for all measurements is listed in Table 3.



TABLE 1. INSTRUMENT QUANTITIES (Cont'd)

Item	Model	COAXIAL SYSTEMS (Frequency in kmc)												WAVEGUIDE SYSTEMS (Frequency in kmc)												Description	Mir.	Price
		1-2		2-4		S		C		J		H		X		P		K		R								
		FAIP	FAIP	FAIP	FAIP	FAIP	FAIP	FAIP	FAIP	FAIP	FAIP	FAIP	FAIP	FAIP	FAIP	FAIP	FAIP	FAIP	FAIP	FAIP	FAIP	FAIP						
23	526C	1	-	-	-	-	-	-	-	-	-	-	-	-	-	-	-	-	-	-	-	-	Period Multiplier	Ⓟ	\$ 225			
24	540B	1	-	1	-	1	-	1	-	1	-	1	-	1	-	1	-	1	-	1	-	1	Transfer Oscillator	Ⓟ	750			
25	608C	1	2	1	-	-	-	-	-	-	-	-	-	-	-	-	-	-	-	-	-	-	VHF Signal Generator	Ⓟ	1000			
26	612A	1	2	1	-	-	-	-	-	-	-	-	-	-	-	-	-	-	-	-	-	-	UHF Signal Generator	Ⓟ	1200			
27	614A	-	-	1	2	1	-	-	-	-	-	-	-	-	-	-	-	-	-	-	-	-	UHF Signal Generator	Ⓟ	1950			
28	616B	-	-	-	-	1	2	1	-	-	-	-	-	-	-	-	-	-	-	-	-	-	UHF Signal Generator	Ⓟ	1950			
29	618B	-	-	-	-	-	-	-	1	2	1	-	-	-	-	-	-	-	-	-	-	-	SHF Signal Generator	Ⓟ	2250			
30	620A	-	-	-	-	-	-	-	-	1	2	1	-	-	-	-	-	-	-	-	-	-	SHF Signal Generator	Ⓟ	2250			
31	626A	-	-	-	-	-	-	-	-	-	1	2	1	-	-	1	2	1	-	-	-	-	SHF Signal Generator	Ⓟ	3250			
32	628A	-	-	-	-	-	-	-	-	-	-	-	-	-	-	1	2	1	-	-	-	-	SHF Signal Generator	Ⓟ	3250			
33	724AR	1	-	1	-	1	-	1	-	1	-	1	-	1	-	1	-	1	-	1	-	1	Standby Power Supply	Ⓟ	on request			
34	764D	1	1	-	-	-	-	-	-	-	-	-	-	-	-	-	-	-	-	-	-	-	Coaxial Dual Directional Coupler	Ⓟ	160			
35	765D	1	1	-	-	-	-	-	-	-	-	-	-	-	-	-	-	-	-	-	-	-	Coaxial Dual Directional Coupler	Ⓟ	160			
36	766D	-	-	-	1	1	-	-	-	-	-	-	-	-	-	-	-	-	-	-	-	-	Coaxial Dual Directional Coupler	Ⓟ	150			
37	767D	-	-	-	-	-	1	1	-	-	-	-	-	-	-	-	-	-	-	-	-	-	Coaxial Dual Directional Coupler	Ⓟ	150			
38	803A	-	1	-	-	-	-	-	-	-	-	-	-	-	-	-	-	-	-	-	-	-	VHF Bridge	Ⓟ	800			
39	805A	-	1	-	-	-	-	-	-	-	-	-	-	-	-	-	-	-	-	-	-	-	Slotted Line	Ⓟ	450			
40	809B	-	-	-	-	-	-	-	1	-	1	-	1	-	1	-	1	-	1	-	1	-	Universal Probe Carriage	Ⓟ	160			
41	814B	-	-	-	-	-	-	-	-	-	-	-	-	-	-	-	-	-	-	-	-	-	Universal Probe Carriage	Ⓟ	200			
42	872A	-	2	2	1	-	2	2	1	-	2	2	1	-	2	2	1	-	2	2	1	-	Slide-Screw Tuner	Ⓟ	545			
43	938A	-	-	-	-	-	-	-	-	-	-	-	-	-	-	-	-	-	-	-	-	-	Frequency Doubler Set	Ⓟ	1500			
44	940A	-	-	-	-	-	-	-	-	-	-	-	-	-	-	-	-	-	-	-	-	-	Frequency Doubler Set	Ⓟ	1500			



TABLE 2. WAVEGUIDE QUANTITIES

Item	Model	S 2.6-4 kmc		G 3.9-5.9 kmc		J 5.3-8.2 kmc		H 7-10 kmc		X 8.2-12.4 kmc		P 12.4-18 kmc		K 18-26.5 kmc		R 26.5-40 kmc		Description	Mfr.
		FAIP	Price	FAIP	Price	FAIP	Price	FAIP	Price	FAIP	Price	FAIP	Price	FAIP	Price	FAIP	Price		
1	281A	3	421 \$ 50.	2	321 \$ 40.	2	321 \$ 35.	2	321 \$ 30.	2	321 \$ 25.	-	-	-	-	-	-	Waveguide to Coaxial Adapter	Ⓢ
2	MX292A	-	-	-	-	-	-	-	-	1	21 - 40.	-	-	-	-	-	-	Waveguide Adapter	Ⓢ
3	MP292A	-	-	-	-	-	-	-	-	-	-	1	21 - \$40.	-	-	-	-	Waveguide Adapter	Ⓢ
4	NP292A	-	-	-	-	-	-	-	-	-	-	1	21 - 40.	-	-	-	-	Waveguide Adapter	Ⓢ
5	NK292A	-	-	-	-	-	-	-	-	-	-	-	-	1	1 - \$40.	-	-	Waveguide Adapter	Ⓢ
6	M362A	-	-	-	-	-	-	-	-	1	21 - 125.	1	21 - 125.	-	-	-	-	Low-Pass Filter	Ⓢ
7	N362A	-	-	-	-	-	-	-	-	-	-	1	21 - 125.	1	1 - 125.	-	-	Low-Pass Filter	Ⓢ
8	375A	2	1 - 120.	2	1 - 110.	2	1 - 100.	2	1 - 90.	2	1 - 90.	2	1 - 100.	2	1 - 140.	2	1 - \$180.	Variable Attenuator	Ⓢ
9	P421A	-	-	-	-	-	-	-	-	-	-	1	1 - 105.	-	-	-	-	Crystal Mount	Ⓢ
10	S485A	1	11 - 140.	-	-	-	-	-	-	-	-	-	-	-	-	-	-	Detector Mount	Ⓢ
11	485B	-	-	1	21 - 95.	1	21 - 90.	1	21 - 85.	1	21 - 75.	-	-	-	-	-	-	Detector Mount	Ⓢ
12	487B	-	-	-	-	-	-	-	-	-	-	1	110.	-	-	1	150.	The rmistor Mount	Ⓢ
13	752A	1	1 - 375.	1	1 - 250.	1	1 - 140.	1	1 - 120.	1	1 - 100.	1	1 - 115.	2	-	2	-	Directional Coupler	Ⓢ
14	752C	3	1 - 375.	3	1 - 250.	3	1 - 140.	3	1 - 120.	3	1 - 100.	3	1 - 115.	2	1 - 175.	2	1 - 200.	Directional Coupler	Ⓢ
15	752D	1	-	1	-	1	-	1	-	1	-	1	-	1	-	1	-	Directional Coupler	Ⓢ
16	S810A	-	-	-	-	-	-	-	-	-	-	-	-	-	-	-	-	Slotted Section	Ⓢ
17	810B	-	-	1	-	1	-	1	-	1	-	1	-	1	-	1	-	Slotted Section	Ⓢ
18	815B	-	-	-	-	-	-	-	-	-	-	-	-	1	-	1	-	Slotted Section	Ⓢ
19	870A	1	21 - 225.	1	21 - 185.	1	21 - 150.	1	21 - 130.	1	21 - 125.	1	21 - 130.	2	1 - 250.	2	1 - 300.	Slide-Screw Tuner	Ⓢ
20	914	2	1 - 100.	1	-	2	1 - 70.	2	1 - 60.	2	1 - 50.	2	1 - 55.	2	1 - 250.	2	1 - 250.	Moving Load	Ⓢ
21	920A	1	-	1	-	1	-	1	-	1	-	1	-	1	-	1	-	Adjustable Short	Ⓢ
22	P932A	-	-	-	-	-	-	-	-	-	-	1	-	250.	-	-	-	Harmonic Mixer	Ⓢ

TABLE 2. WAVEGUIDE QUANTITIES (Cont'd)

Item	Model	S 2.6-4 kmc		G 3.9-5.9 kmc		J 5.3-8.2 kmc		H 7-10 kmc		X 8.2-12.4 kmc		P 12.4-18 kmc		K 18-26.5 kmc		R 26.5-40 kmc		Description	Mfr.
		FAIP	Price	FAIP	Price	FAIP	Price	FAIP	Price	FAIP	Price	FAIP	Price	FAIP	Price	FAIP	Price		
23	MA-513E	-	-	-	-	-	-	-	-	-	-	-	-	-	-	-	-	Crystal Mount	Microwave Associates
24	MA-595B	-	-	-	-	-	-	-	-	-	-	1	90.	-	-	-	-	Crystal Mount	Microwave Associates
25	MA 1039C	-	-	-	-	-	-	-	-	-	-	-	-	2	140.	-	-	Crystal Mount	Microwave Associates
26	529	-	-	-	-	-	-	-	-	-	-	1	90.	-	-	-	-	Barretter Mount	Narda
27	354E	-	1 \$100.	-	-	-	-	-	-	-	-	-	-	-	-	-	-	90° E-Plane Bend	Narda
28	450	-	-	-	1 \$70.	-	-	-	-	-	-	-	-	-	-	-	-	90° E-Plane Bend	PRD
29	454	-	-	-	-	1 \$50.	-	-	-	-	-	-	-	-	-	-	-	90° E-Plane Bend	PRD
30	458	-	-	-	-	-	1 \$35.	-	-	-	-	-	-	-	-	-	-	90° E-Plane Bend	PRD
31	462	-	-	-	-	-	-	-	-	1 \$30.	-	-	-	-	-	-	-	90° E-Plane Bend	PRD
32	618	-	-	-	-	-	-	-	-	-	-	-	-	-	-	1 115.	-	Barretter Mount	PRD
33	620	-	-	-	-	-	-	-	-	-	-	-	-	1 115.	-	-	-	Barretter Mount	PRD
34	6605	-	-	-	-	-	-	-	-	-	-	-	-	1 1 140.	-	-	-	Crystal Mount	PRD
35	6606	-	-	-	-	-	-	-	-	-	-	-	-	-	-	1 1 140.	-	Crystal Mount	PRD

TABLE 3. MISCELLANEOUS EQUIPMENT

In addition to the equipment in the Master List, any set-up requires a number of miscellaneous instruments, components and hardware such as those listed below. RF cables are supplied with some signal generators. Type N shorts are supplied with the 760 series coupler, the 803A, and the 805A. Crystals are supplied with slotted line probes.

<u>MODEL</u>	<u>DESCRIPTION</u>	<u>TYPICAL MFR.</u>	<u>PRICE</u>
<u>HARDWARE</u>			
----	Adapter, Type N, Male-Male(UG-57B/U)	Gremar	--
----	Adapter, Type N, Female-Female (UG-29B/U)	or	--
----	Adapter, Type N, Male to BNC Female (UG-201A/U)	Amphenol	--
AC-76A	Adapter, Male BNC to Binding Posts	Ⓢ	\$ 5.00
----	Adapter, 115 volts, 3-wire to 2-wire	Cornish Wire, Hubbel	--
----	Barretters (Sperry 821, PRD 617, 631-C, Narda N-604)	Sperry, PRD, Narda	--
AC-16C	Cable Assembly, Type N, Female-Male	Ⓢ	10.50
AC-16F	Cable Assembly, Type N, Male-Male	Ⓢ	12.00
AC-16Q	Cable Assembly, Type N, Male-Male (above 4 kmc)	Ⓢ	14.00
AC-16K	Cable Assembly, BNC, Male, Male	Ⓢ	5.00
AC-16B	Cable Assembly, BNC Male to Twin Banana Plugs	Ⓢ	5.00
AC-16A	Cable Assembly, Banana Plugs to Banana Plugs	Ⓢ	4.00
----	Crystals (1N21, 1N23, 1N26, 1N53, 1N78, 1N1132)	Sylvania, Micro- wave Associates	--
----	Modified crystals, 1N26, 1N53, 1N78	Ⓢ	Write
----	Headphones (for use with 417A)	Trimm	--
----	Leads, alligator clip to alligator clip	Herman H. Smith or Insuline	--
----	Lead, alligator clip to banana plugs	General Radio	--
8A-76H	Short, Type N, Female	Ⓢ	4.00
803A-76G	Short, Type N, Male	Ⓢ	4.50
----	Tee, Type N, Female (UG-28/U)	Gremar or	--
----	Tee, BNC (UG-274/U)	Amphenol	--
25	Waveguide Clamp (for use in Model 24)	Ⓢ	2.50
----	Waveguide Short (blank flange)	----	--
X930A	Waveguide Shorting Switch	Ⓢ	100.00
24	Waveguide Stand	Ⓢ	3.00
<u>TEST EQUIPMENT</u>			
151A	High Frequency Oscilloscope	Ⓢ	1100.00
151B	High Gain Amplifier	Ⓢ	200.00
410B	Vacuum Tube Voltmeter	Ⓢ	245.00
400B	Vacuum Tube Voltmeter (unless included for power measurements)	Ⓢ	325.00
<u>CALIBRATION EQUIPMENT</u>			
738AR	Voltmeter Calibrator (for calibrating voltmeters and oscilloscopes)	Ⓢ	375.00
739AR	Frequency Response Test Set (measure VTVM frequency response over range of 350 kc to 11 mc)	Ⓢ	450.00
200SR	Oscillator (extends range of 739AR down to 5 cps)	Ⓢ	185.00

