

---

# Fundamentals of Time Interval Measurements

Application Note 200-3

Electronic Counter Series

---





# Table of Contents

<b>Precision Time Interval Measurement</b>	
<b>Using an Electronic Counter .....</b>	<b>5</b>
Preface .....	5
<b>Time Interval Measurement Using an Electronic Counter .....</b>	<b>6</b>
Introduction .....	6
What can be Measured .....	6
How Measurement is Made .....	7
<b>Resolution .....</b>	<b>8</b>
One-Shot Measurements .....	8
TI Averaging .....	8
Minimal Interval, Dead Time and Pulse Width .....	9
<b>Start and Stop Signal Input Channels .....</b>	<b>10</b>
General .....	10
Desirable Characteristics .....	10
Controls Associated with Time Interval Measurements .....	11
Input Circuit Operation as it Affects the User .....	11
<b>Input Signal Conditioning Controls and</b>	
<b>Trigger Circuit Operation.....</b>	<b>13</b>
Signal Conditioning Controls Set the Trigger Point .....	13
Other Input Controls .....	13
Trigger Operation .....	16
Determining the Hysteresis Window and Triggering at Zero Volts .....	24
Hysteresis Compensation .....	27
Polarity Control .....	29
Input Attenuators for Measuring Higher Amplitude Signals .....	30
Trigger Lights .....	30
Markers .....	31
Delay $\Delta$ Control .....	34
<b>Time Interval Averaging .....</b>	<b>36</b>
Reduce +1 or -1 Count Error by $\sqrt{N}$ on Repetitive Signals .....	36
Time Interval Averaging is Useful When .....	36
Synchronizers Needed for True TI Averaging .....	37
Extending Time Interval Measurements to Zero Time .....	38
Disadvantages of Time Interval Averaging .....	39
<b>Time Interval Error Evaluation .....</b>	<b>40</b>
+1 Count Error or -1 Count Error .....	40
$\pm$ Trigger Error .....	40
$\pm$ Time Base Error .....	48
$\pm$ Systematic Error .....	49
<b>Time Intervals by Digital Interpolation .....</b>	<b>50</b>
Digital Interpolation .....	50
Phase-Startable Phase-Lockable Oscillators (PSPLO) .....	50
The Dual Vernier Method .....	50

<b>The Generation of Precise Time Intervals .....</b>	<b>52</b>
Phase-Startable Phase-Lockable Oscillators .....	52
<b>Time Interval Measurement Using the</b>	
<b>HP 5363B Time Interval Probes .....</b>	<b>54</b>
Solve Troublesome TI Measurements Problems .....	54
Level Calibration .....	56
Time Zero Calibration .....	58
To Make a TI Measurement Using the HP 5363B .....	59
<b>Some Applications of Time Interval Measurements .....</b>	<b>60</b>
Simple Timing System with Start-Stop Pulses Generated by	
Mechanical Switches .....	60
Phase Measurement .....	61
Measuring Complex Pulse Trains .....	63
<b>Comparison with Other Ways of Making Time Interval</b>	
<b>Measurements on Narrow Pulses or Fast Rise Signals .....</b>	<b>67</b>

# Precision Time Interval Measurements Using an Electronic Counter

## Preface

A time interval measurement is a measurement of the elapsed time between some designated START phenomena and a later STOP phenomena. This is in contrast to real-time observations (time of day) used in our day-to-day living to schedule meetings or transportation, in astronomical observations and for celestial navigation among other things. One might make a time interval measurement with a mechanical stopwatch as when timing a track meet or other sporting event or in making time and motion studies. With increased speed of the timed object as when timing automobiles or airplanes the timed interval becomes shorter and shorter until the human factor involved in determining when to start and when to stop the measuring device, a stopwatch or clock for instance, begins to introduce significant error. Mechanical, optical, or electrical transducers or a combination of all were developed to reduce this error. Finally with advances in many scientific fields, mechanical and electrical time measurements were required which were beyond the resolution of a mechanical stopwatch. This led to the development of a time interval measuring electronic counter, in essence an electronic stopwatch. A time interval counter can measure electrical delays, pulse widths, and other time related electrical phenomena required in the development and maintenance of communications, navigation, television, and other present day systems. Increased measurement capability has helped bring on more and more sophistication in all of these fields until now modern electronic time interval counters are used to measure electrical events spaced as close as 0.1 nanosecond (the time required for light to travel 3 centimeters) on a "one-shot" basis. Time interval averaging on repetitive events gives still greater resolution than this.

# Time Interval Measurement Using an Electronic Counter

## Introduction

Time Interval is an important measurement frequently made with electronic counters. In this role, the counter makes an elapsed time measurement between two electrical pulses, Figure 1, just as a stopwatch is used to time physical events.

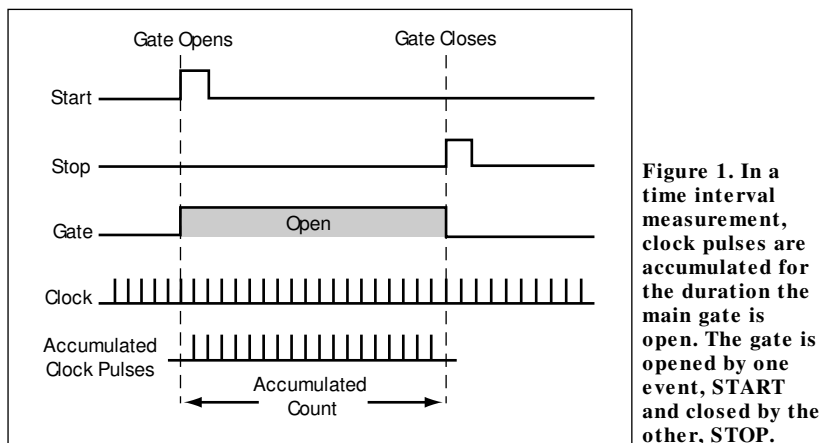

Figure 1. In a time interval measurement, clock pulses are accumulated for the duration the main gate is open. The gate is opened by one event, START and closed by the other, STOP.

Minimum time measurement is much less (to a nanosecond and below) than possible with a stopwatch. Also resolution and accuracy are much greater than attainable with a stopwatch.

## What Can Be Measured

Some typical time measurements that might be made are:

### Characterization of Active Components

- Propagation delay of integrated circuits

### Radar Ranging

### Nuclear and Ballistic Time of Flight

### Pulse Measurements

- Width
- Rise Time
- Repetition Rate (Period) of pulse train
- Spacing on complex pulse trains such as used by airborne identification and navigation systems

### Cable Measurements

- Propagation Time
- Cable Length

### Phase

### Delay Line Measurements

Time interval measurements can also be made on any physical phenomena that can be translated into appropriate electrical signals. Transducers such as photo electric cells, magnetic pickups, strain gauges, micro-switches, bridge wire systems, or thermistors can be used to translate physical events into the electrical start and stop signals required for a time interval measurement.

## How Measurement is Made

The START pulse, received at channel A of the counter in Figure 2A, opens the GATE to start the measurement, the STOP pulse occurring later in time and received at channel B closes the gate to end the measurement. Elapsed time between start and stop is measured by counting the Time Base “clock” frequency while the gate is open.

The resolution of a conventional time interval counter (HP 5328A, HP 5345A, etc.) is determined by its “clock” frequency. A clock frequency of 1 MHz gives 1  $\mu$ sec resolution, 100 MHz gives 10 ns resolution, 500 MHz gives 2 ns resolution and so on. Clearly, the elements within the time interval counter (input amplifier, main gate, DCAs) must operate at speeds consistent with the clock frequency; otherwise the instrument’s resolution would be meaningless. Present state-of-the-art limits resolution to about 2 nsec, although special techniques can improve on this.

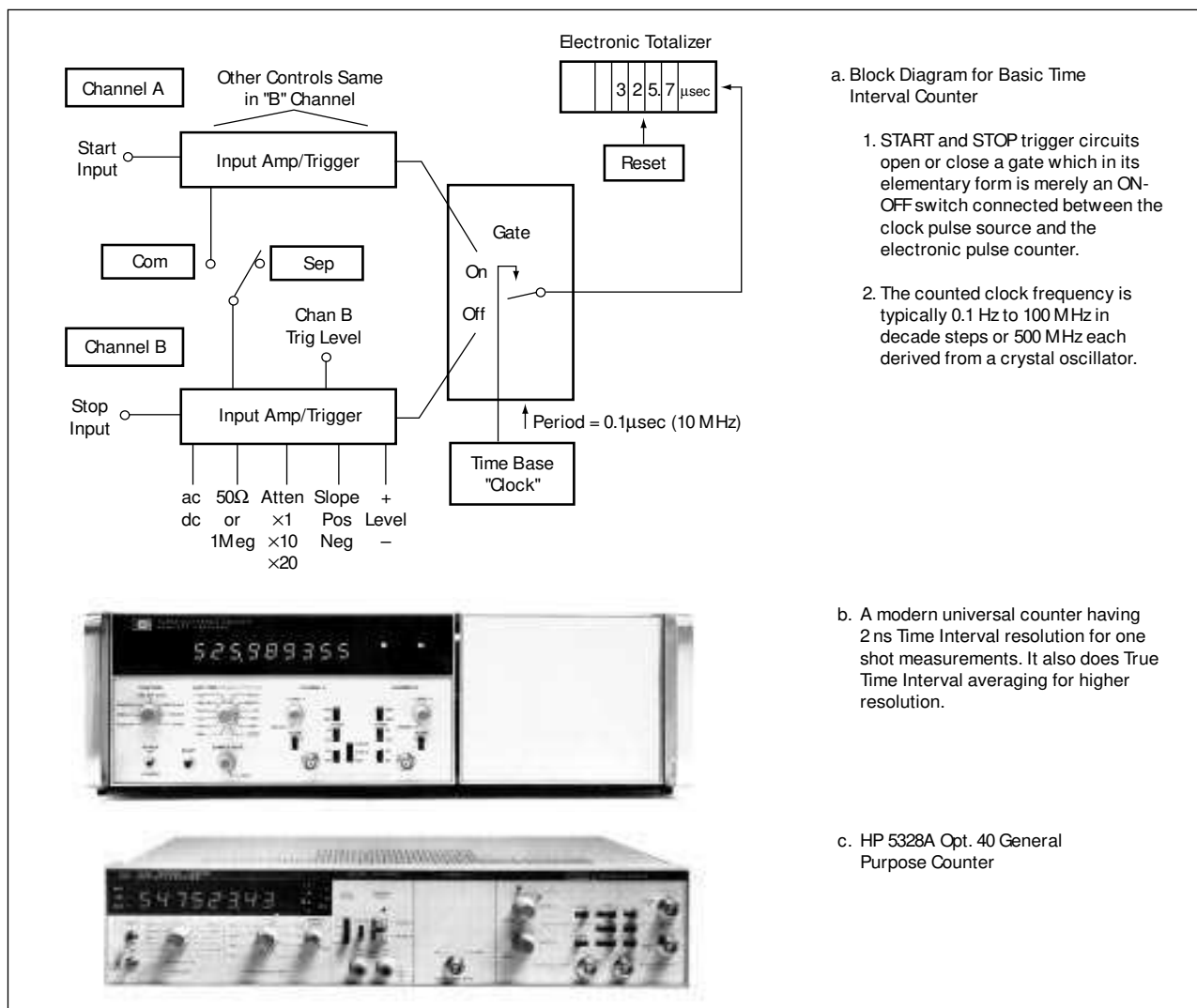

Figure 2. Measuring Time Interval with an Electronic Counter

# Resolution

## One-shot Measurements

Most general purpose counters will make a “one-shot” (the time between a single pair of start and stop pulses) time interval measurement with resolution to 100 nanoseconds — i.e., the counter counts a 10 MHz clock. The HP 5328A offers either 100 ns or 10 ns resolution depending on the configuration. The HP 5345A will resolve a one-shot time interval measurement to 2 nanoseconds. By way of reference 2 nanoseconds is the time it takes light to travel six tenths of a meter.

For conventional counters, direct readout is achieved by using clock frequencies related by powers of 10 — i.e., 1 MHz, 10 MHz, 100 MHz, etc., (period of 1  $\mu$ s, 100 ns, 10 ns, respectively) and a correctly placed decimal point and annunciator. Single shot resolution of conventional counters is limited to 10 ns as the next step up, 1 ns resolution, requires a 1 GHz direct count decade which at present is not economically feasible. Counters which have arithmetic capability are not limited in this way as the measurement can be made with any convenient clock period then translated to engineering units before being displayed. The HP 5345A, a reciprocal counter, counts in 2s of nanoseconds then does a multiply by 2 before displaying a time interval measurement. Some sophisticated modern counters like the HP 5370A operate on a digital interpolation scheme which allows single shot resolving capability of 20 ps. However, with resolution this high other factors like noise in the input amplifiers or on the input signal become limiting factors. Perhaps a realistic way to look at resolution would be to say it is the probable repeatability from measurement to measurement for a given set of circumstances. Since the two noise components limiting resolution are statistical in nature the resolution must be described in statistical terms. For example, 30 ps rms would be a typical description of resolution when using the HP 5370A.

## TI Averaging

Time interval averaging can be used to get resolution to the picosecond ( $10^{-12}$  sec) region on a repetitive signal. Averaging operates on the assumption that the factors limiting resolution are random in nature and will tend to average towards zero. A counter needs synchronizers in gate circuits and a noise modulated clock to achieve TRUE TIME INTERVAL AVERAGING with accuracy and repeatability independent of the input signal repetition rate. The HP 5345A and HP 5328A with Option 040 Universal Module both have this true averaging capability.

## Minimum Interval, Dead Time and Pulse Width

Three important specifications are sometimes overlooked when considering time interval measurements.

1. The minimum time interval or minimum range specification is the minimum time between start and stop pulses which the counter will recognize. For single shot measurements in a conventional counter this time must always be one or more clock periods. However, if interpolation is used this time can be reduced to in the region of 20 ps. A more typical specification is 100 ns corresponding to the period of a 10 MHz clock. Another technique for reducing the minimum time interval is to use averaging with synchronizers. This allows intervals of less than one clock period to be measured but a repetitive signal is required.
2. The minimum dead time is the time from a stop pulse to the acceptance of the next start pulse. Typical dead time specifications are 10 ns for the HP 5345A, 150 ns for the HP 5328A. Dead time determines the maximum upper repetition rate of an acceptable signal.
3. The minimum pulse width is the shortest pulse the counter will recognize as a start or a stop pulse and is largely determined by the bandwidth of the input amplifiers. The typical minimum pulse width for a 50 MHz counter is 10 ns or the period of half a cycle.

Some measurement errors may result if these specifications are not considered. For example, if a rise time is being measured which is less than the minimum time interval specification the first stop to be recognized will be on the next pulse giving a measurement result corresponding to the pulse period instead of the desired rise time.

# Start and Stop Signal Input Channels

## General

High resolution is meaningless if measurements on a stable signal are not repeatable as only the digits that consistently repeat represent accurate information. Since the input amplifier-trigger circuits of the counter are the interface from the signal of interest to the counter they are the most critical circuit elements in accurate time interval measurements. Their performance directly influences measurement accuracy. Lack of attention to these circuits as related to the measurement is the prime source of measurement error and the major reason a counter's potential accuracy is often not achieved.

The input amplifier and trigger circuits, one for the start channel and one for the stop channel, establish the voltage level at which an input signal will trigger the counter. Noise, drift, ac-dc coupling, and other factors relating to these circuits all influence the measurement. Since these circuits are so important it is worthwhile looking in some detail at the operation of one of these input channels.

## Desirable Characteristics

Several requirements must be met by each input if a time interval counter is to make useful measurements:

1. The input circuits must be able to accept a signal which might be a sine wave, square wave, pulse, or a complex waveform of varying amplitude and generate from that signal one and only one output pulse of constant amplitude, rise time and width for each cycle of the input.
2. The circuit will need controls to let the operator choose the exact voltage point on the input waveform at which he wants to START and STOP his measurement. This is necessary to achieve flexibility of measurement.
3. The input should have a means of externally setting and/or measuring the trigger point voltage to facilitate setting up a measurement.
4. The input needs good stability with time and temperature and low internal noise so that once set, triggering will occur at the same voltage level regardless of input signal amplitude, wave shape, or duty cycle.
5. The input should be dc coupled so the trigger voltage point will not change with repetition rate or duty cycle of the input signal yet be capable of ac coupling for measurements on signals with a dc offset.

6. Input circuit protection is necessary so inadvertently applied high amplitude signals, regardless of duration, will not damage input circuit components.
7. High input impedance (high input resistance and low input capacitance) is desirable for bridging measurements (connecting directly across an input signal) with minimum input waveform distortion yet switchable to 50 ohms to provide a good termination and thus prevent reflections when doing fast pulse work in a 50 ohm environment.
8. Provision to connect the start and stop inputs together is desirable to simplify time interval measurements on a signal appearing on a single cable. This is necessary for measuring pulse width for instance.
9. Matched input amplifiers are a necessity for meaningful time interval measurements on fast rise time or high frequency signals. If one channel has significantly less bandwidth than the other, propagation delay and rise time will be vastly different for the two. This introduces large errors in measurements involving high frequency signals.

## **Controls Associated with Time Interval Measurements**

Slope, level and attenuator controls which determine the trigger point on the input waveform give the operator flexibility in setting up a measurement. Understanding the function of each control is important or triggering may not occur at the expected voltage point on the input signal.

## **Input Circuit Operation as it Affects the User**

All electronic counters have an input sensitivity specification, i.e., 100 mVrms for sine waves (282 mV peak-to-peak), which indicates the minimum voltage necessary to operate the counter. This specification normally applies over the full environmental range as well as takes into account aging effects, therefore when operated at a moderate room temperature, sensitivity may be significantly better than the specification. Sensitivity may change with aging, with ambient temperature or other environment changes; however, for a well designed circuit these effects are held to a minimum. Also sensitivity may depend on frequency.

For frequency measurement, selecting the trigger point is not too critical, the sole requirement being that the counter trigger once (and only once) for each cycle of the input signal. Accurate time interval measurement however, places a much more exacting requirement on the input circuits as they must trigger precisely at the selected trigger voltage set up by the input controls.

Time interval is a two dimensional problem. The dimensionality of the time interval measurements is illustrated by the simple example of Figure 3, measuring signal rise time.

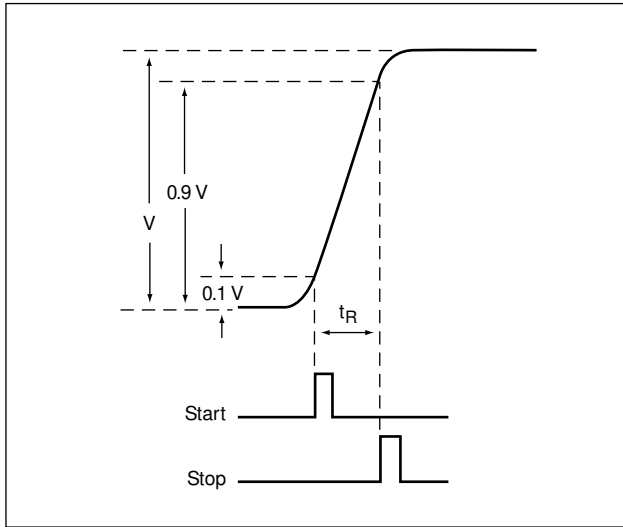

**Figure 3.** Measuring the rise time  $t_R$  by adjusting the trigger levels to the 10% and 90% points of the input amplitude.

The time interval meter must generate a START signal at the 10 or 20% amplitude point of the input signal and generate a STOP signal at the 80 or 90% point. Clearly this is different from the frequency or period measuring case when the input triggers at the same point on the waveform from cycle-to-cycle of the input. Inherent in the time interval measurement, therefore, is the dual dimensionality, amplitude and time. It is this dimensionality that places much more stringent requirements on the input amplifier-triggers than those necessary for the measurement of frequency or period.

Any deviation from the selected trigger point because of circuit drift degrades the accuracy of the measurement as the counter time base “clock” will not be counted for the proper interval. Obviously, if the clock used for timing the electrical events is not started or stopped at the right moment, the measurement will be incorrect just as measurements made with a stopwatch if it is not started or stopped at the right moment.

# Input Signal Conditioning Controls and Trigger Circuit Operation

## Signal Conditioning Controls Set the Trigger Point

Figure 4 shows the effects of the SLOPE, POLARITY, LEVEL, and ATTENUATOR controls in establishing the trigger voltage point on the input signal.

1. **The SLOPE control** determines whether the trigger point will be on a rising or a falling voltage as in Figure 4a.
2. **The POLARITY control** determines whether the trigger point is positive or negative with respect to zero volts as in Figure 4b.
3. **The LEVEL control** adjusts the trigger point of the circuit up or down in voltage and usually has a range of from one to three volts peak for a counter with 100 mV rms (282 mV peak-to-peak) sensitivity as in Figure 4c. The polarity and level functions are often combined using a zero center variable control having a range of -3 volts to 0 to +3 volts.

Most counters also have a PRESET switch position at one end of the level control range to set up the most sensitive trigger condition for ac coupled symmetrical input signals. Functioning of these controls as they relate to setting a trigger point are discussed in detail later.

4. **The INPUT ATTENUATOR** reduces high amplitude input signals up to 100 volts or more so these fall within the dynamic range of the amplifier/trigger circuits which are limited to a few volts rms maximum as in Figure 4d.

## Other Input Controls

1. SEPARATE COMMON Switch

A SEPARATE common switch ties the START and STOP inputs together without having to resort to external cables or hardware. On counters with 50 $\Omega$  inputs this is done using appropriate matching networks so the input looks like 50 $\Omega$  for either the SEPARATE or COMMON mode of operation. Depending on the circuit configuration this may or may not result in a 2:1 loss in voltage sensitivity.

## 2. 50 OHM-HIGH IMPEDANCE Switch

Some modern counters have a panel switch to select a high input impedance (1 meg, 35 pF) for bridging applications or 50 ohm input impedance to provide a good termination (low VSWR) for a 50 ohm transmission line. If the counter has a 50Ω position the whole input circuit up to the gate of Q<sub>1</sub> (Figure 6) is designed as a 50 ohm strip line. Also, the overload protection resistor R<sub>1</sub> is shorted out so the operator must be more careful when measuring high amplitude input signals (usually 5V rms maximum) or the input circuit can be damaged.

## 3. dc-ac Coupling

All general purpose time interval counters have a dc coupled amplifier trigger circuit so as to maintain a consistent trigger point on input signals down to zero frequency. AC coupling, when needed, is achieved by connecting a capacitor, C<sub>1</sub>, in series with the input connector either with a switch or through a second input connector. AC coupling is necessary when measuring a signal with a large dc offset; however, the trigger point changes with both the input frequency and duty cycle when using ac coupling.

## 4. CHECK

While not strictly related to time interval measurements, the SELF CHECK function checks the multiplier, divider, and gate circuits of a counter for correct operation and should be done before using a counter. The self check function does **not** give any indication of crystal oscillator accuracy.

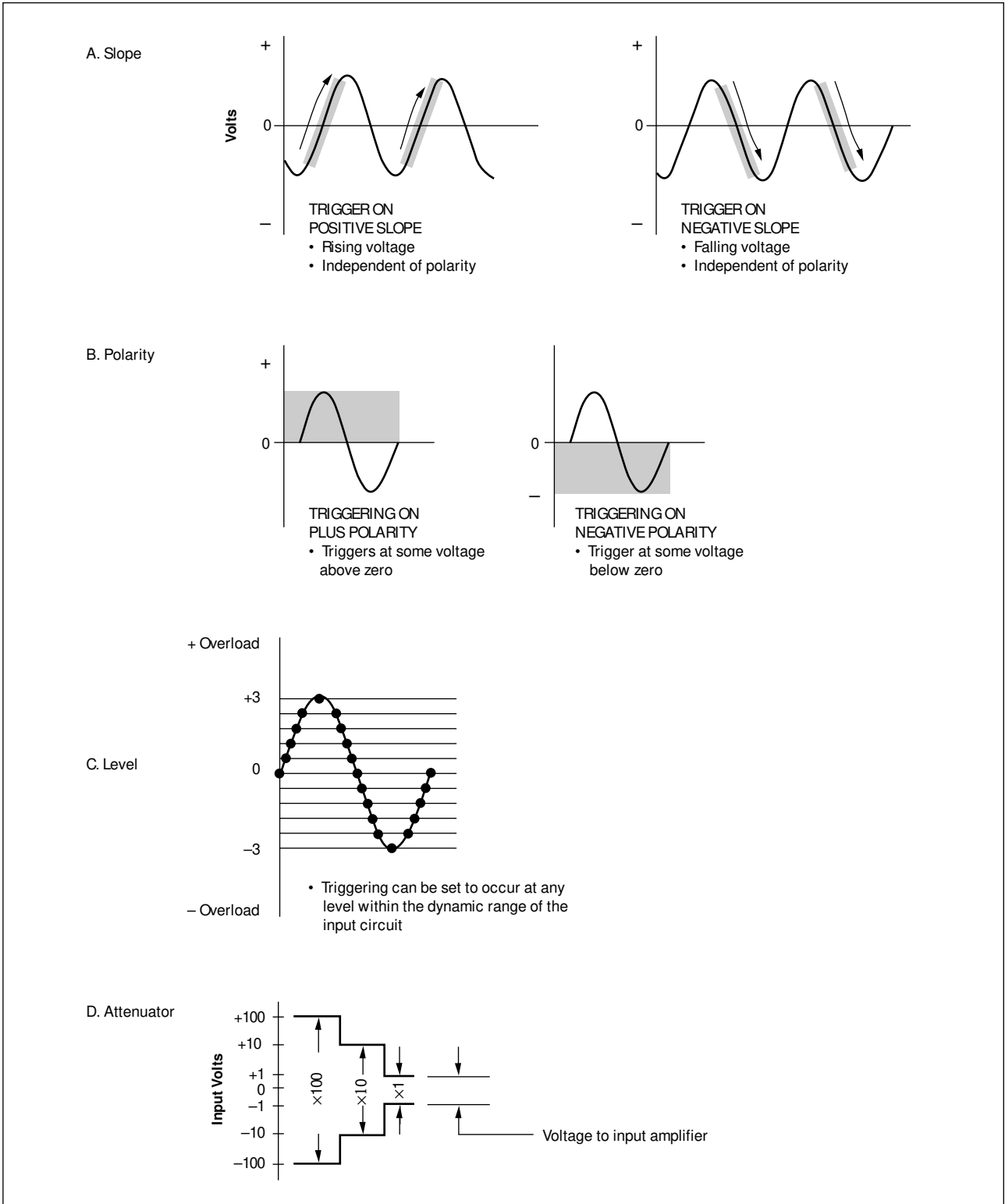

Figure 4. The three parameters under operator control which define the trigger point on an input signal.

## Trigger Operation

The input amplifier trigger circuit accepts the input signal which may vary in amplitude, frequency, and wave shape. It puts out one pulse of constant amplitude and width as required by the internal counter circuits each time the input signal crosses the selected trigger voltage point.

### 1. HYSTERESIS LIMITS define input sensitivity

The input signal must cross **two** voltage thresholds to activate the trigger circuit. The sensitivity of the electronic counter is determined by the voltage difference between these two thresholds, called hysteresis limits, which define the hysteresis window of the trigger circuit. The hysteresis limits correspond to voltage levels on the input signal, one of which will trigger the circuit Figure 5a, at (m) and the other voltage level which will reset the trigger circuit at (n). A plot, Figure 5b, of the transfer function of the trigger output

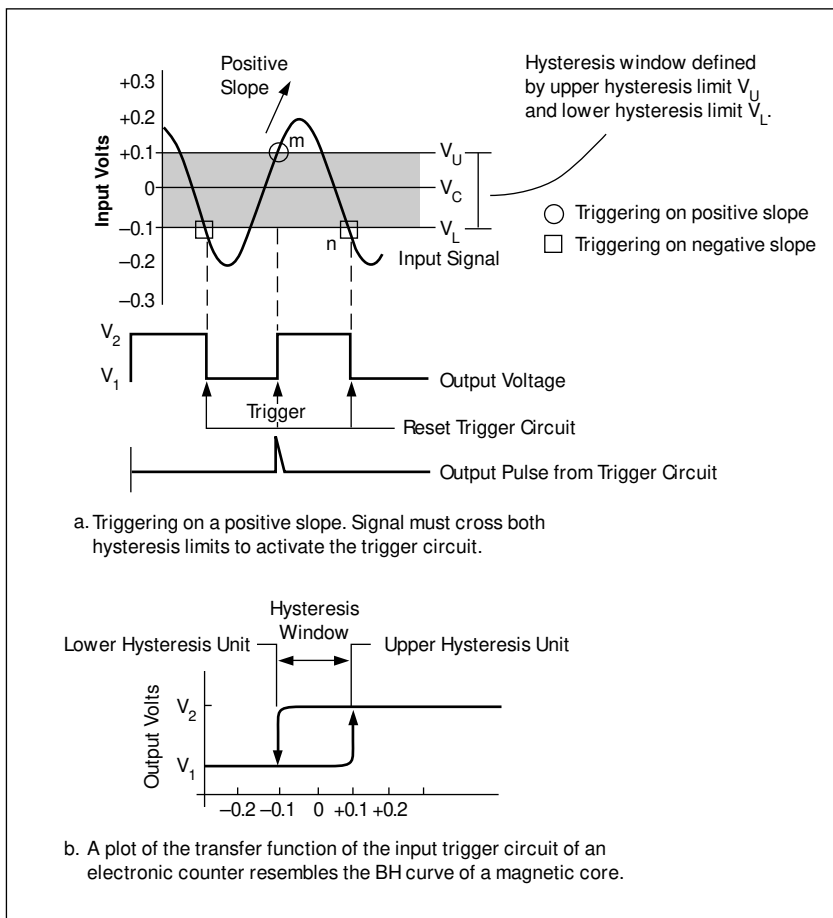

Figure 5. Hysteresis limits and transfer function of a trigger circuit.

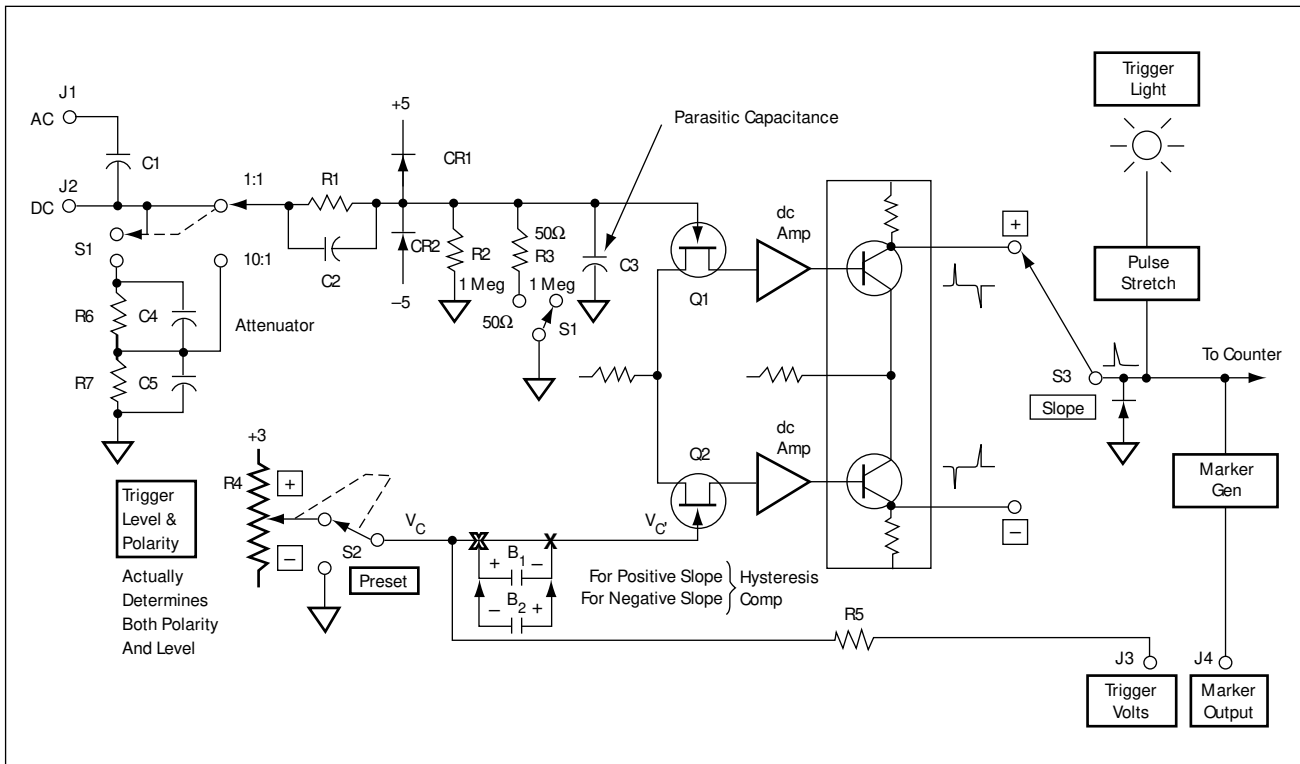

Figure 6. Symmetrical Input Amplifier Trigger Circuit for Time Interval Counter.

voltage resembles the familiar BH curve (flux density vs. magnetizing force) or hysteresis curve of a magnetic core. Even though these hysteresis limits define the trigger and reset voltage points on the input signal they do **not** exist as nodes (component junctions) anywhere in the circuit so the trigger voltage point cannot be measured directly. There is, however, a voltage  $V_C$  approximately half way between the hysteresis limits that does exist as a physical circuit node which can be measured with a dc voltmeter to determine the trigger point. This will be discussed later. Once the circuit has triggered, it cannot be retriggered until the input signal crosses the opposite hysteresis limit then once more crosses the level of interest.

It is important to note that if the signal crosses only one limit then returns to its original level the circuit will **not** trigger. The signal **must** pass all the way through the hysteresis window to cause either triggering or reset of the input trigger circuit. Hysteresis limits are defined by peak voltages, however most counter sensitivities are specified in rms volts; therefore, the specified rms sensitivity must be multiplied by 2.82 to convert to peak-to-peak volts to get an indication of input sensitivity for other than sine wave inputs.

This triggering action might be compared to a mouse trap. With the trap, nothing happens until the trigger is depressed below a certain point at which time the trap is sprung. Operation of the trap once tripped is independent of how fast or how slow the trigger was depressed. Once sprung, further movement of the trigger has no effect until the trap is reset. Triggering the trap corresponds to crossing the upper hysteresis limit (m) of Figure 5a, resetting the trap corresponds to crossing the lower limit (n) for this example.

## 2. TRIGGER CONTROLS as they relate to the input circuit

The diagram, Figure 6 of a typical input amplifier for one channel of a solid state time interval counter shows the circuit elements which are directly influenced by the setting of panel controls. A look at the circuits associated with each control helps understand the correct setting procedure needed to make valid time interval measurements.

### a. Input Attenuator

The frequency compensated input attenuator,  $R_6R_7C_1C_5$ , reduces an input level up to 100 volts or more by a factor of 100:1, 20:1, 10:1, or 2:1 (sometimes labeled x100, x20, x10, x2) to a level that can be safely applied to the input amplifier circuit. One usually thinks of an attenuator as a device that reduces the input signal to the linear range of the input amplifier. With respect to the signal, another way to look at attenuator operation is that it multiplies the hysteresis window of the counter by the attenuation factor. For example, the counter with a 25 mVrms sensitivity (hysteresis limits  $25 \times 2.82 = 70.5$  millivolts apart) would have 250 mVrms sensitivity (hysteresis limits  $25 \times 2.82 \times 10 = 705$  millivolts apart) on the X10 attenuator setting. Even though large signals applied to a sensitive range may not damage the counter the overload may cause miscounting.

### b. Overload Protection

Diodes  $CR_1$  and  $CR_2$  in conjunction with  $R_1$  provide overload protection to prevent damage to  $Q_1$  in case of accidental overload.  $R_1$  is large enough to prevent damage with an input signal as high as 115 volts rms at power line frequency on the most sensitive attenuator range of most counters. A capacitor,  $C_2$ , across this resistor prevents sensitivity roll off at high frequencies. Important to the operator is the fact that at high frequencies,  $C_2$  effectively shorts out the protection resistor  $R_1$  so maximum voltage is limited to a few volts rms, Figure 7, rather than 100 volts or more as at low frequencies.

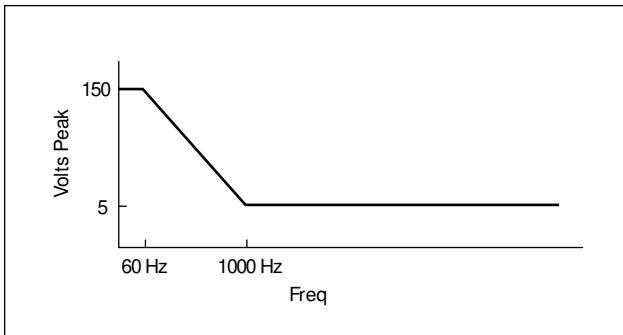

**Figure 7. Overload voltage as a function of frequency.**

Also important to the operator is the fact that the protective diodes  $CR_1$  and  $CR_2$  can change the input characteristics of the counter. So long as the input signal is below  $\pm 5$  volts peak the diodes  $CR_1$  and  $CR_2$  for the circuit in Figure 5 are back biased so have no effect. If the peak input signal goes beyond these limits however, the input resistance of the counter drops from 1 megohm down to a value perhaps as low as a few hundred ohms dependent on the value of  $R_1$ . This places a heavy non-linear load on the signal source which may drastically alter its waveshape. For normal operation the input signal must be kept below this overload level even though the input circuit may not be damaged because double counting or other erratic counting may occur due to the shape of the altered input signal. When working with a transducer such as a tachometer generator which has an output proportional to rotational speed, the simple external limiter shown in Figure 8 is effective in preventing counter overload for a signal that varies over wide amplitude limits. When using this circuit, the source always sees a minimum load of 22K at the input to the limiter so ringing and other distortion is not a problem. When working with low frequency sources (below 50 kHz) such as tachometer and flowmeter pickups  $C_1$ , in the range of 100 to 500 pF, keeps high frequency noise from causing false triggering. The input signal is symmetrically clipped as amplitude increases so the trigger point of the counter must be set between  $\pm 0.5$  volts.

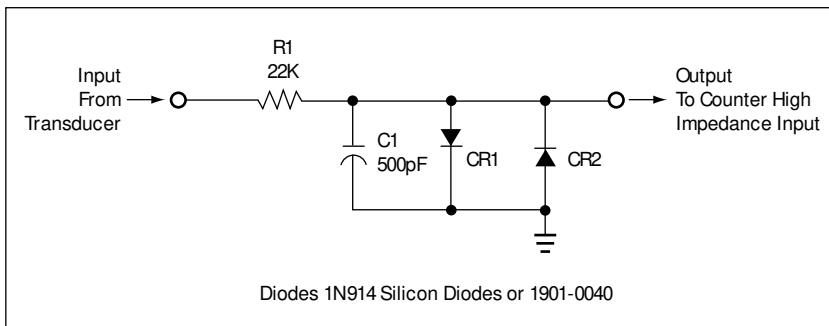

**Figure 8. Simple clipper circuit to prevent counter input overload.**

### c. dc or ac Coupling

For time interval measurements dc coupling is very important, as triggering is generally required at a specific voltage point on the input waveform. With ac coupling the location of the trigger point varies with respect to zero volts dc anytime the pulse width, repetition rate, rise time, or waveshape (any change that effects average dc level) are changed. The shift in the measuring point is shown in Figure 9 and Figure 10. Zero volts is defined in each case by positioning the waveform such that the average voltage above zero equals the average voltage below zero for a repetitive signal. This also implies that for any symmetrical waveshape — sinewave, triangle wave, square wave, etc. — zero volts will be at the center of the waveform.

Use of ac coupling causes only simple translation of the waveform along the voltage axis as in Figures 9d, 10b, or 10d if the RC time constant of the coupling network is long compared to the period of the waveform of interest. When coupling circuit time constants are of the same order as the period of the input signal, the waveform is distorted as well as translated as in Figure 9e. With yet shorter time constants ( $R_1$  decreased in value) the circuit changes from a coupling to a differentiating network with resultant signal transmission and waveform distortion as in Figures 9f and 9g. In each instance the counter input sees quite a different input signal although the generator output signal remains unchanged.

These waveforms point up rather dramatically some of the problems associated with making time interval measurements using ac coupled amplifier/trigger circuits. If a counter had been set to trigger on a positive slope at + zero volts dc for instance, it would have triggered at the peak of the waveform Figure 9c if dc coupled. If ac coupled it would have triggered near the middle of the input signal, Figure 9d or near the top of some cycles and near the bottom of others, Figure 9e, depending on circuit constants. This shift is through no malfunction of the counter input circuits but rather is due to the characteristics of the ac coupling network. (These same factors cause the vertical shift of an oscilloscope display if the duty cycle of the input signal is changed in the ac coupled mode of operation.) AC coupling may be unavoidable under some circumstances, as when the signal has a large dc component, so it is up to the operator to recognize the attendant problems and determine what signal the time interval input is really seeing or the actual trigger point may be far removed from the desired trigger point.

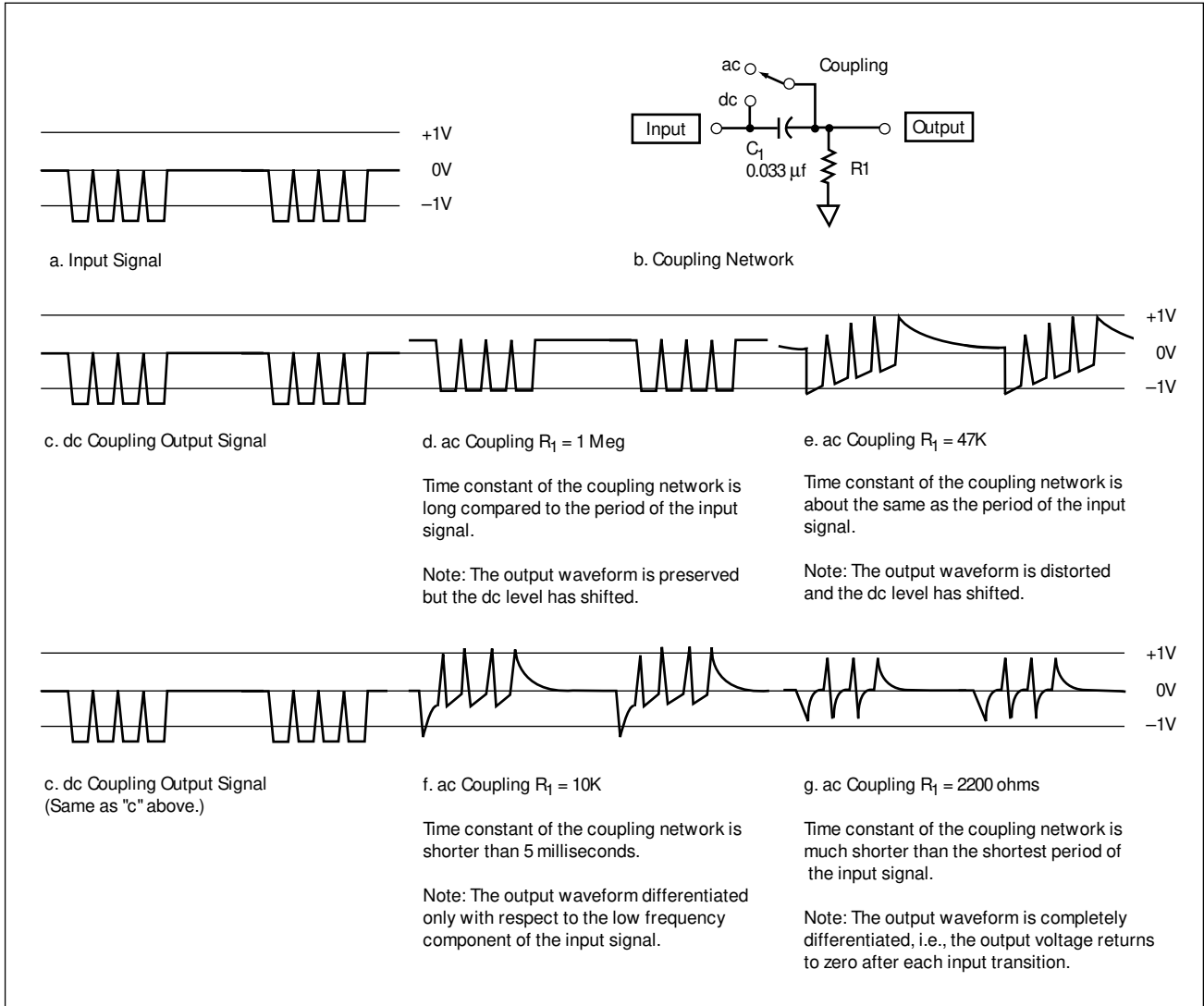

Figure 9. dc and ac Coupling for a complex pulse train.

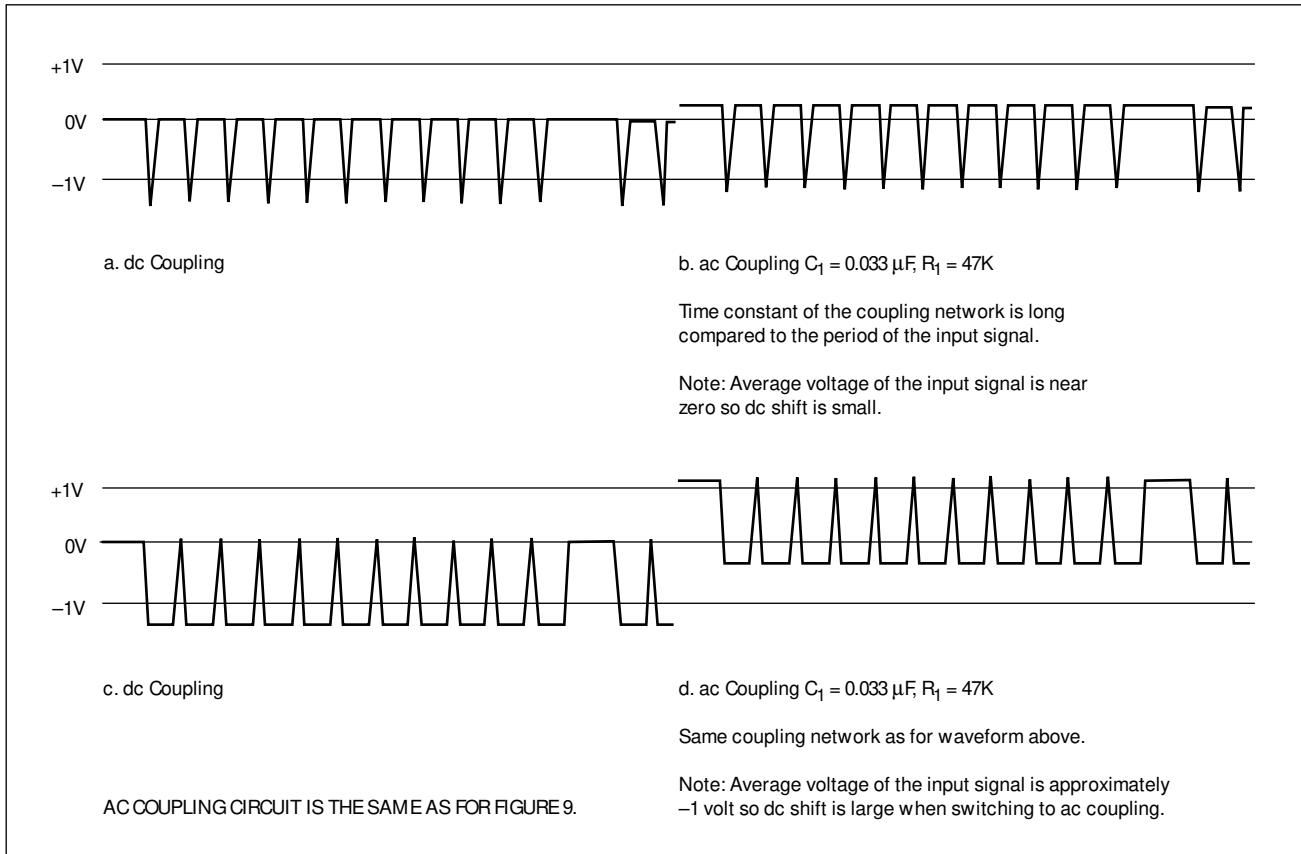

Figure 10. dc or ac Coupling illustrating change in Zero Level with Pulse Width.

d. Slope Control

The slope control,  $S_3$  Figure 6, determines if the circuit is triggered by a signal with a positive (+) slope (going from one voltage to a more positive voltage regardless of absolute polarity) to generate an output pulse at the upper hysteresis limit ( $V_U$ ) of Figure 5a, or by a signal with a negative (-) slope which causes an output pulse to be generated at the lower hysteresis limit ( $V_L$ ).

e. Level Control

Moves hysteresis window voltage-wise. The level control,  $R_4$  Figure 6 moves the center of the hysteresis window  $V_C$  to any positive or negative voltage within the dynamic range of the input

circuit without appreciably changing the window as in Figure 11. Best sensitivity for an ac coupled, sine wave input signal is with the hysteresis limits positioned symmetrically with respect to 0 volts dc since the smallest amplitude signal can now cross both limits. Many counters have a PRESET position at one end of the range of the LEVEL control to set up this condition. (Triggering will occur at either the upper or lower hysteresis limit depending on the setting on the SLOPE control.)

The voltage  $V_C$  which defines the approximate center of the hysteresis limits comes from the arm of the TRIGGER LEVEL control,  $R_4$ , Figure 6, so can be measured with a dc voltmeter. This voltage is often brought to a panel connector,  $J_3$ , for ease of measurement. A resistor,  $R_5$ , of several thousand ohms may be included to prevent circuit damage if  $J_3$  is accidentally shorted; therefore, a high impedance voltmeter should be used.

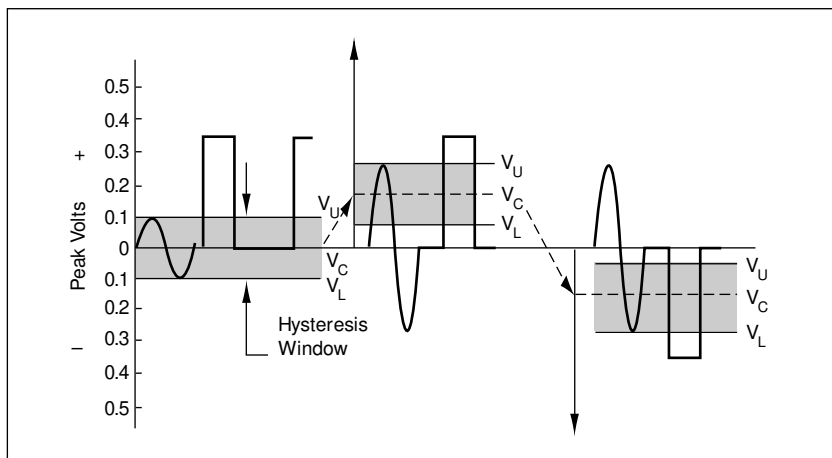

Figure 11. Polarity and Level Controls

f. Triggering at a Particular Voltage

To actually trigger at a particular voltage, either the upper hysteresis limit,  $V_U$ , or lower hysteresis limit  $V_L$ , (once again depending on slope) must be positioned at the desired voltage level using the LEVEL control. This is not easy since  $V_U$  or  $V_L$  cannot be measured with a voltmeter as mentioned earlier. Instead, one must measure the hysteresis window peak-to-peak voltage, Figure 12, then add  $1/2$  this value to  $V_C$  when triggering on a positive slope or subtract when triggering on a negative slope to determine the actual trigger point.

$$V_{\text{Trigger}} = V_C + \frac{V_U - V_L}{2} \text{ for positive slope}$$

$$V_{\text{Trigger}} = V_C - \frac{V_U - V_L}{2} \text{ for negative slope}$$

Where:  $V_C$  can be measured with a dc voltmeter.

The hysteresis window,  $V_U - V_L$ , can be determined using procedures outlined in the following section.

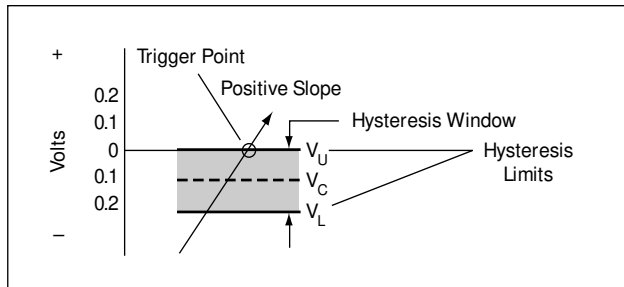

**Figure 12. To trigger at a particular voltage (zero volts dc in this example) with a positive slope. Upper and lower hysteresis limits are positioned as shown above.**

## Determining the Hysteresis Window and Triggering at Zero Volts

The distance between the hysteresis limits  $V_U - V_L$  (hysteresis window) which defines input sensitivity can be determined using one of these methods:

1. Methods of Measuring of Hysteresis Window and Determining  $V_C$ 
  - a. The first method, Figure 13a, measures the hysteresis window by counting a low distortion 10 kHz to 100 kHz sine wave input to the counter. Reduce the input amplitude, readjust the trigger LEVEL control, then repeat these steps to determine the minimum amplitude signal that will just trigger the counter. The hysteresis limits are then spaced by the peak-to-peak sine wave voltage. This is  $2.82 \times$  rms input voltage measured with an ac voltmeter. A calibrated dc coupled oscilloscope and a sine wave or a square wave generator could also be used in a similar manner. In this case, the  $\times 2.82$  factor is not needed since an oscilloscope already displays peak-to peak volts.
  - b. The second method, Figure 13b, is the inverse of the first method in that the hysteresis limit of interest is moved through a zero volt input signal to establish triggering at zero volts. For triggering on a positive slope, the counter input is first grounded insuring zero volts input, then the trigger LEVEL control is turned to its most positive extreme after which it is decreased slowly until the input circuit just triggers. Triggering occurs when the upper hysteresis limit coincides with the input voltage which is zero because of the grounded input terminal. Voltage  $V'_C$ ,  $\frac{V_U - V_L}{2}$  and negative in this case, can be measured at  $J_3$  with a dc voltmeter. This voltage which is one-half the hysteresis window is added to other  $V_C$  settings to get the actual trigger voltage for any settings within the linear range of the LEVEL control. The same can be done when triggering on a negative slope except the trigger LEVEL control is first turned to its most negative extreme then slowly advanced until the circuit just triggers. The measured difference voltage is subtracted from

other  $V_C$  readings to get the actual trigger voltage.

- c. A third method of determining  $\frac{V_U - V_L}{2}$ , Figure 13c, requires a square wave generator with a variable output amplitude that swings between some minus voltage and zero or between zero and some plus voltage. Zero volts must be accurately at 0 as any residual offset will give incorrect results. For triggering on the positive slope, turn the LEVEL control on the counter to its most positive extreme. Connect a 10 kHz square wave that goes from -1 volt to 0 to the input of the counter. Slowly decrease the trigger LEVEL until the counter just begins to trigger. This happens when the upper hysteresis limit coincides with upper excursion (0 volts) of the input square wave. Triggering is at zero volts and  $V_C$  can be measured as before. A similar procedure can be used to establish triggering at zero

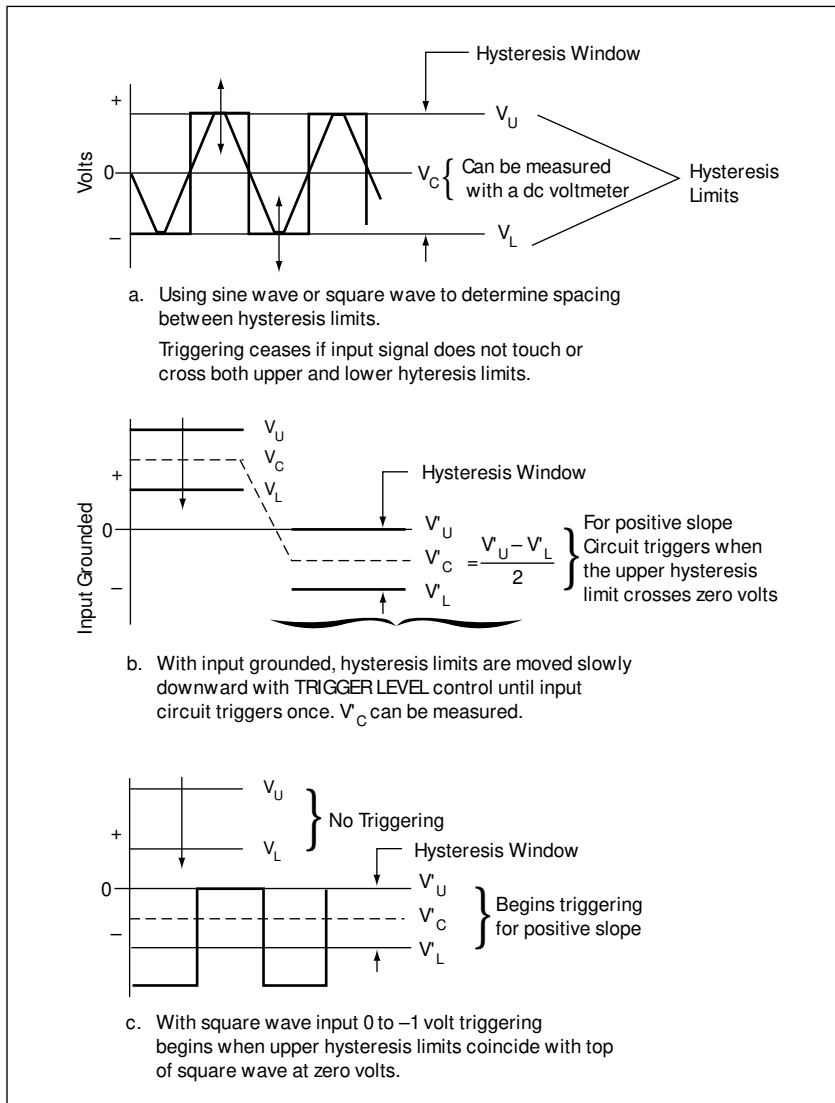

**Figure 13.** Determining the hysteresis window, i.e., spacing between hysteresis limits, which define the sensitivity of an electronic counter and setting trigger levels at zero volts.

volts with a negative slope. In this case, the square wave output is from +1V to 0 volts and the LEVEL control is initially offset to its negative extreme.

## 2. Establishing Triggering at Zero Volts on a Sine Wave

- d. Establishing triggering at zero volts on a sine wave signal. A method particularly convenient on sinewave signals is determining if triggering does indeed occur at zero volts using the following procedure: A time interval measurement is set up using any convenient trigger point. The start channel input amplitude is then changed by some factor, 2:1 for instance, and observing if the counter time interval reading changes or not. This is shown in Figure 14. (It is important that neither the source impedance or counter input impedance change when the amplitude change is made. A change of either would change the phase of the input signal as well as its amplitude.)

If the start channel is triggering at (a) of Figure 13 the counter will change because the trigger point will shift to (b) with an accompanying time change when the input amplitude is changed. Readjust the start LEVEL slightly and repeat the amplitude change. Continue until the counter reading is the same for either amplitude. The start channel is now triggering at zero volts (c) and the time of triggering is independent of input signal amplitude. Repeat the same procedure for the stop channel to get it triggering at zero volts also.

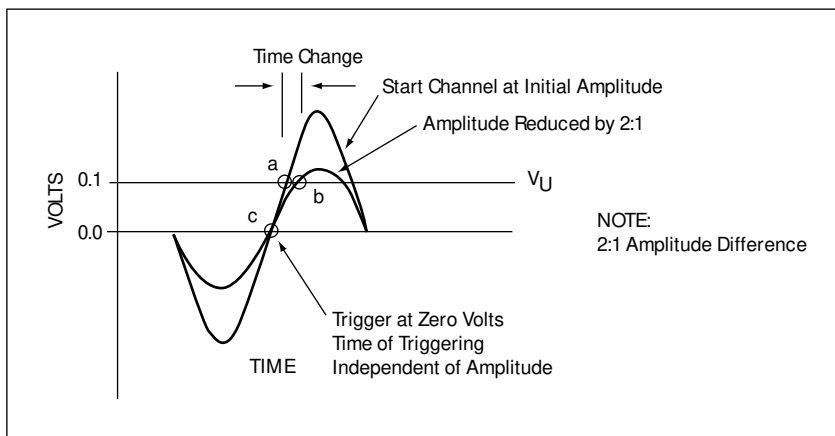

**Figure 14. Setting START or STOP Channels to trigger at zero volts dc on a sine wave.**

## Hysteresis Compensation

### 1. What is Hysteresis Compensation?

A conventional counter triggers on the upper hysteresis limit at (a) Figure 15 when set to trigger on a positive slope and at (b) the lower hysteresis limit when set to trigger on a negative slope.

Triggering will always occur regardless of the setting of the SLOPE switch if the input signal is large enough to cross both hysteresis limits; however, the trigger point on the input waveform shifts to a different voltage whenever the SLOPE switch is changed.

The voltage  $V_C$  can be measured to give an indication of the trigger level but it is offset by about half the hysteresis window so does not define the exact trigger voltage.

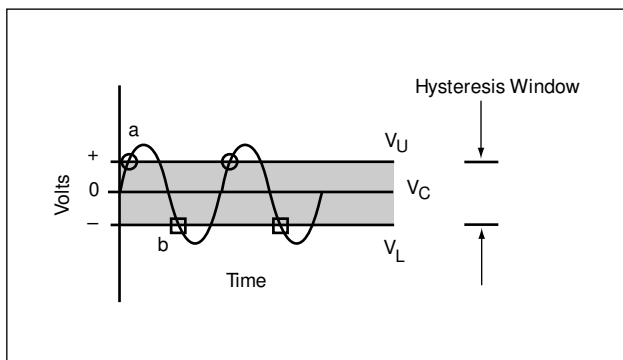

**Figure 15.**  
Triggering on  
positive or  
negative slope.

Hysteresis compensation keeps the trigger point at approximately the same voltage even though the trigger SLOPE is changed from positive to negative by introducing a voltage,  $B_1$  or  $B_2$  of Figure 6, between the level control,  $R_4$ , and the trigger circuit. Figure 16 shows the upper hysteresis limit  $V_U$  shifted down to  $V'_U$  by this built-in voltage source which introduces an offset or “buck out” voltage between the trigger LEVEL control and the trigger circuit to move  $V_C$  to  $V_C$ . This voltage corresponds to the battery  $B_1$  or  $B_2$  in Figure 6. The magnitude of this offset voltage is one-half the hysteresis window. Note that the upper hysteresis limit (trigger voltage for a positive slope) is now opposite  $V_C$ . A dc voltmeter, internal to the counter or external can thus be used to indicate the trigger voltage by measuring the voltage at the arm of the trigger LEVEL control on a counter that has this hysteresis compensation feature. When triggering on a negative slope, operation of the compensation circuit is similar except  $V_C$  is shifted upward so  $V'_L$  coincides with  $V_C$  instead of downward as for a positive slope.

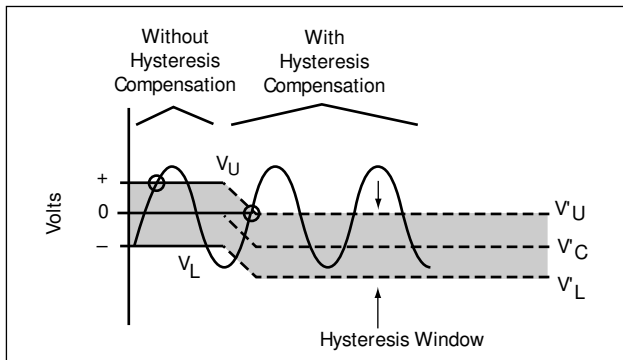

**Figure 16.**  
Hysteresis compensation for triggering on a positive slope.

## 2. Limitations

A counter with hysteresis compensation may quit counting when the slope switch is changed as the input signal may no longer cross both hysteresis limits. This places no limitation on a measurement a counter having hysteresis compensation can make however, as this would also happen in trying to get a conventional counter to trigger at the same voltage point. The only difference is that the operator would use the manual LEVEL control to shift the hysteresis limits rather than have them shift automatically when the SLOPE switch is changed. While giving a better indication of trigger level than an uncompensated trigger, this technique has limitations:

- a. The measured trigger voltage  $V_C$ , see Figure 6, established a reference voltage for one-half of a balanced amplifier, and is related to the signal voltage into the other half.

Any gain change or drift between the two halves of the amplifier with time, temperature, or other environmental factors will destroy the initially set fixed relationship between  $V_C$  and the actual trigger voltage.

- b. If the input amplifier does not have a flat frequency response, the hysteresis window Figure 17 changes with frequency (corresponds to change in rise time for TI measurements) so no single internally generated “buck out voltage” will be correct over the frequency range of the counter. This results in a discrepancy between the measured trigger voltage and the actual trigger voltage point.

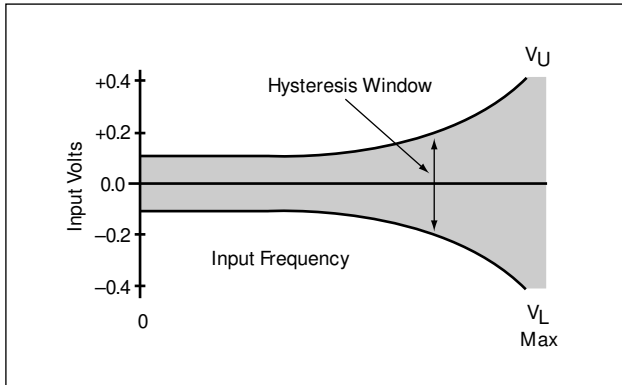

**Figure 17.**  
Hysteresis window gets wider if input sensitivity decreases with increasing frequency.

### 3. HP 5328A Option 040 and HP 5326A/B, 5327A/B have Hysteresis Compensation

The HP 5328A Option 040 and the HP 5326A/B and HP 5327A/B counters have this hysteresis compensation feature in the time interval mode of operation. An HP 5328A with Option 040 (time interval) and Option 020 or 021 (digital voltmeter) has switch positions labeled READ A and READ B to select and display either Input A (start) or Input B (stop) trigger voltage to 1 millivolt. One millivolt resolution is greater than justified in terms of absolute accuracy of the trigger voltage for reasons mentioned earlier; however, this high resolution is useful as it is possible to:

- a. Return very closely to a previously selected trigger voltage.
- b. Accurately move the trigger point by some small amount since the DVM gives 1 millivolt resolution on  $\Delta V$  readings. This is helpful when determining rise times.

The HP 5326B or HP 5327B which has a built-in DVM also has a READ LEVEL A and READ LEVEL B position to read trigger voltage in the time interval mode.

## Polarity Control

This control determines if the center of the hysteresis window moves to a positive voltage or to a negative voltage from zero when the level control is changed. Most counters have the level control connected between a +V and a -V supply. This puts 0 volts in the center of the control range so a single control functions both as a POLARITY and a LEVEL control as in Figure 6. In this case the control element may have a nonlinear taper to give greater settability around zero volts. The voltage from the arm of the level control to the trigger circuit is often brought to an external connector where it can be measured with a dc voltmeter. This voltage defines the approximate center of the hysteresis window,  $V_C$ .

## Input Attenuator for Measuring Higher Amplitude Signals

A frequency compensated 2:1, 10:1, 20:1, or 100:1 attenuator between the input terminal and the input amplifier permits measurement of high amplitude signals which might otherwise overload or damage the input circuit. This attenuator has the effect of **increasing** the hysteresis window by the attenuation factor, for instance: a counter with 100 mV rms sensitivity would have a hysteresis window of 282 millivolts (peak-to-peak value of 100 mV rms). The x10 position on the attenuation raises sensitivity to 1V rms and the hysteresis window becomes 2.82 volts so signals below this amplitude can no longer be counted. Similar reasoning applies for other attenuation factors.

The SLOPE, POLARITY, LEVEL, and ATTENUATOR controls allow the operator to start or stop a measurement anywhere on an electrical input signal except the most negative part of the signal when triggering on a positive slope or the most positive part of a waveform when triggering on a negative slope. (At the peak, one or the other of the hysteresis limits is no longer crossed by the signal.) Operation of these controls is similar to that on the sweep circuit of a modern oscilloscope. On the oscilloscope these controls determine where, on an input waveform, the sweep begins. On the counter they determine where on the signal the measurement begins and ends.

## Trigger Lights

When measuring time interval the counter displays a reading only if it gets a Start and a Stop pulse. During setup on an unknown signal it is not always obvious if both input channels are triggering or not if the counter is not gating. To make initial setup easier, trigger lights, one for each channel, are often provided. A neon lamp or LED is used to indicate channel activity so the operator can tell by looking at the light if the channel in question is triggering regardless of whether the other is triggering or not. The trigger light drive circuit includes a pulse stretcher to insure that the light stays on long enough to be seen even though the actual input pulse may be too narrow.

### 1. Two-State

Two general types of trigger light presentations are used: The two state display used on the HP 5308A and on the HP 5326/5327 series counters has lights that are OFF when the circuit is not triggering but BLINK when the circuit is triggering. As the input repetition rate increases above about 50 Hz the trigger lights appear to stay on continuously.

## 2. Three-State

The trigger lights of the three state display used on the HP 5328A may be OFF, BLINKING, or ON. A trigger light is OFF if the input is below the trigger level (due to too small a signal, a dc component on the signal or the trigger level control incorrectly set) and ON continuously (but no triggering) when the input is above the trigger level. The light BLINKS each time the input triggers for rates up to about 10 Hz and blinks at about a 10 Hz rate for inputs of 10 Hz to 100 MHz. This not only gives the operator an indication of triggering but also some indication of the problem if the counter is not triggering.

## Markers

Many electronic counters generate electrical signals for use as markers when an input channel is triggered.

Some types of markers are:

### 1. DOT MARKERS

When a channel is triggered it puts out a short duration electrical marker pulse (100 ns wide) that can be used to intensity modulate the trace of an oscilloscope displaying the input signal. The marker shows up on an oscilloscope display as a bright dot on the waveform.

Dot marker pulses, Figure 18a, are useful to indicate the trigger point on a slow rise waveform since marker width and circuit delays are both small compared to the risetime of the input waveform; however, as one gets into fast risetime pulses these effects are no longer insignificant. This coupled with the CRT phosphor rise and decay time makes intensity markers of little use in the nanosecond region as the markers begin to look more like comets than dots so the actual trigger point is no longer well defined.

Dot marker outputs are useful on sine wave signals from 100 Hz to 100 kHz. At higher frequency, the marker width becomes an appreciable part of the period of the input signal so the marker no longer defines a specific point on the input waveform. Also the delay through the intensity modulation (Z axis) amplifier is not usually known so dot markers are of little use in the sub-microsecond region.

At low frequencies, dot markers are not useful unless the dot width is increased as the trace is intensified for such a small portion of one cycle that it is difficult to see the marker. Separate connectors are supplied for the START marker and STOP marker outputs on most time interval counters.

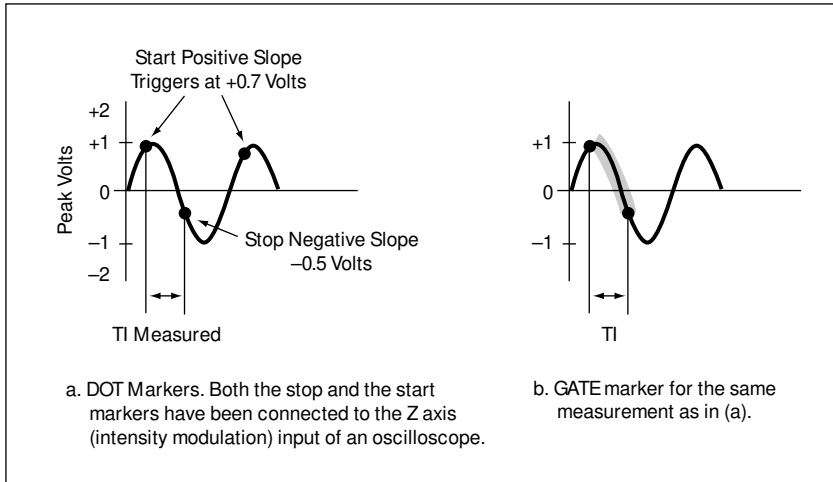
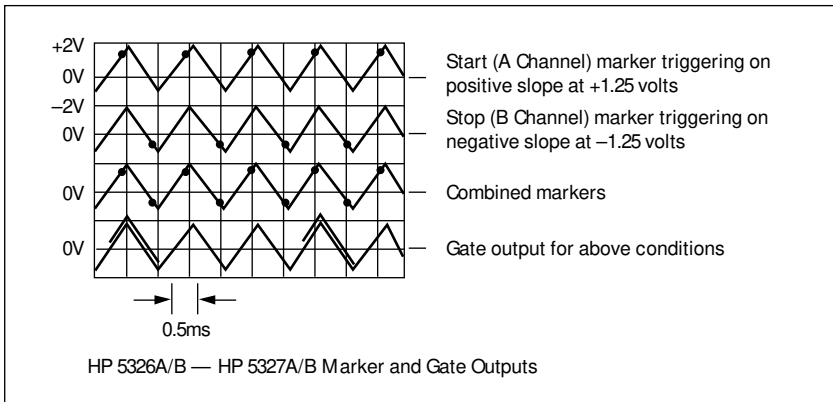

**Figure 18. Time Interval Markers as they appear on an oscilloscope.**

## 2. GATE MARKERS

A gate marker, Figure 18b, generates a dc voltage for the duration of the counter measurement (gate OPEN to gate CLOSE). This can be used to intensify an oscilloscope display of the input signal from the receipt of a START signal by the counter until the receipt of a STOP signal.

High impedance gate markers work well to very low frequencies or to demonstrate basic triggering ideas on time interval measurements but are not useful for fast pulse or short delay measurements as they have the same drawbacks as dot markers. Figure 19 shows markers as they appear on an oscilloscope.



**Figure 19. Actual Dot and Gate Marker Outputs**

**NOTE:** Dot markers come from the trigger circuit so they appear on every input cycle. A gate marker appears only when the gate is open so it does not appear unless the gate opens.

The HP 5345A and HP 5328A Option 040 also have 50Ω gate outputs. These have fast risetime. They are useful over the full frequency range of the counter as this gate output can be displayed on the second channel of a wide band oscilloscope connected to the signal or can be mixed with the input signal before display. These gate markers may be offset from the actual gate time by 10 ns to 100 ns. For detailed information consult the data sheet for a specific counter. Figure 20 and Figure 21 are illustrations of markers.

3. SQUARE WAVE MARKERS

The HP 5328A has 100 mV into 50 ohm marker outputs which are inverted replicas of the Channel A and Channel B Schmitt trigger outputs as in Figure 21b. These can be displayed along with the input signal on a dual channel oscilloscope. These markers are fast enough that they are useful to 100 MHz in a 50Ω system. In general there is some delay between the marker output and actual triggering so the counter data sheet should be consulted for detailed information. The HP 5328A Option 040 High Performance Universal Module has a Channel A marker as described above as well as a gate type marker which is high during a TI A→B measurement. Both are available from front panel connectors.

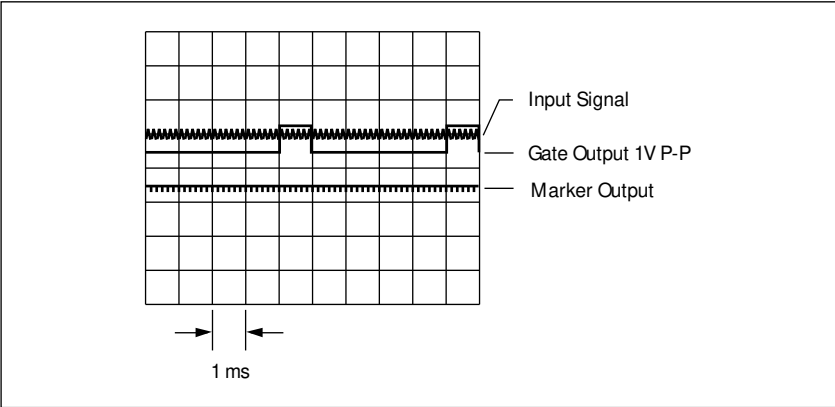

**Figure 20.**  
**HP 5328A Gate**  
**Output 1 peak-to-**  
**peak into 50 ohm**  
**load.**

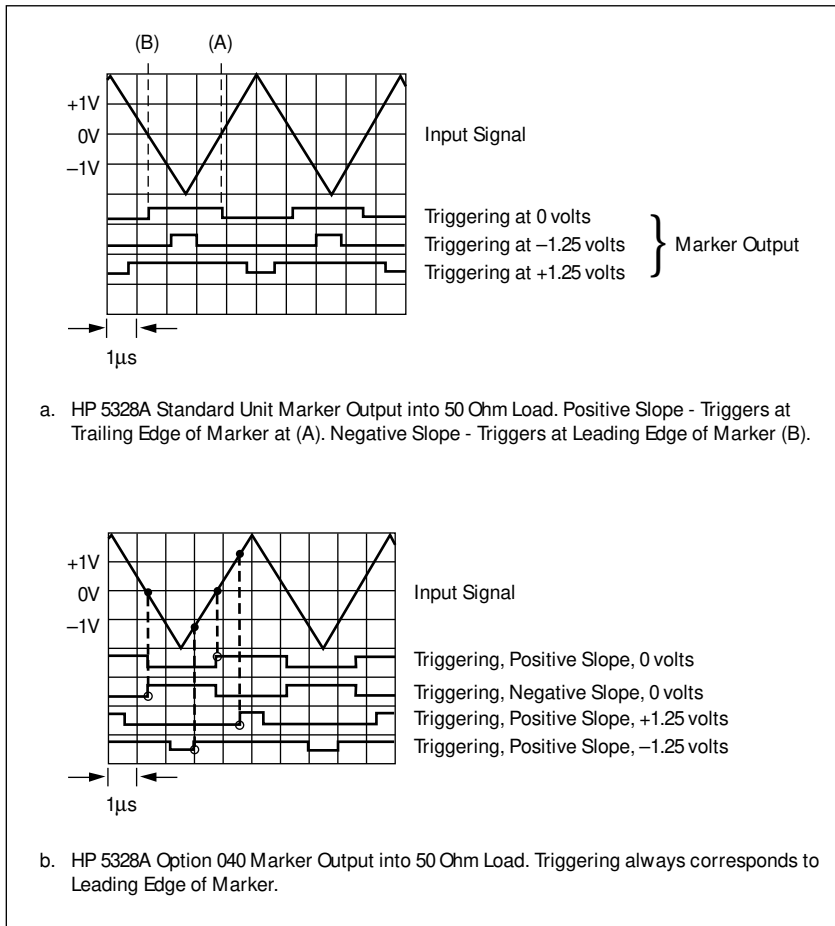

**Figure 21.**  
Square wave  
marker output  
of the HP 5328A  
Counter.

## Delay Control

Besides the conventional input controls, the HP 5328A Option 040 and the HP 5304A each have a DELAY control associated with the start input. This control is useful in making a measurement on a complex or noisy signal. Once a measurement begins (following a START pulse) STOP pulses are locked out until expiration of a pre-determined, adjustable, analog delay. The measurement terminates with the first STOP pulse following delay run down. This feature is useful in relay testing for example as the delay is used to get away from errors due to contact bounce. In Figure 22a, a measurement started at 1 would normally end at 2 on the first bounce. Adjusting the delay time to something greater than 3 but less than 4 lets the operator measure the time from the first contact closure to the first contact opening after the coil is de-energized. Figure 22b illustrates another application where a measurement is required between specific pulses on a complex pulse

train such as that used in ATC (Air Traffic Control) systems for example. Here the DELAY control is used to select specific STOP locations within the pulse train. The SAMPLE RATE control is also helpful as this gives control of the counter "dead time" and so gives some control of the time between pulse trains.

The HP 5345A can also be used for this kind of measurement; however, in this case the DELAY signal is generated by an external generator such as the HP 8007A Pulse Generator. Even greater measurement flexibility is possible with this combination as the pulse generator gives the operator control of both dead time and delay with respect to an externally supplied reference (sync) pulse. Pulse width defines the lock out interval and pulse delay defines the position of the start pulse on the pulse train or other waveform.

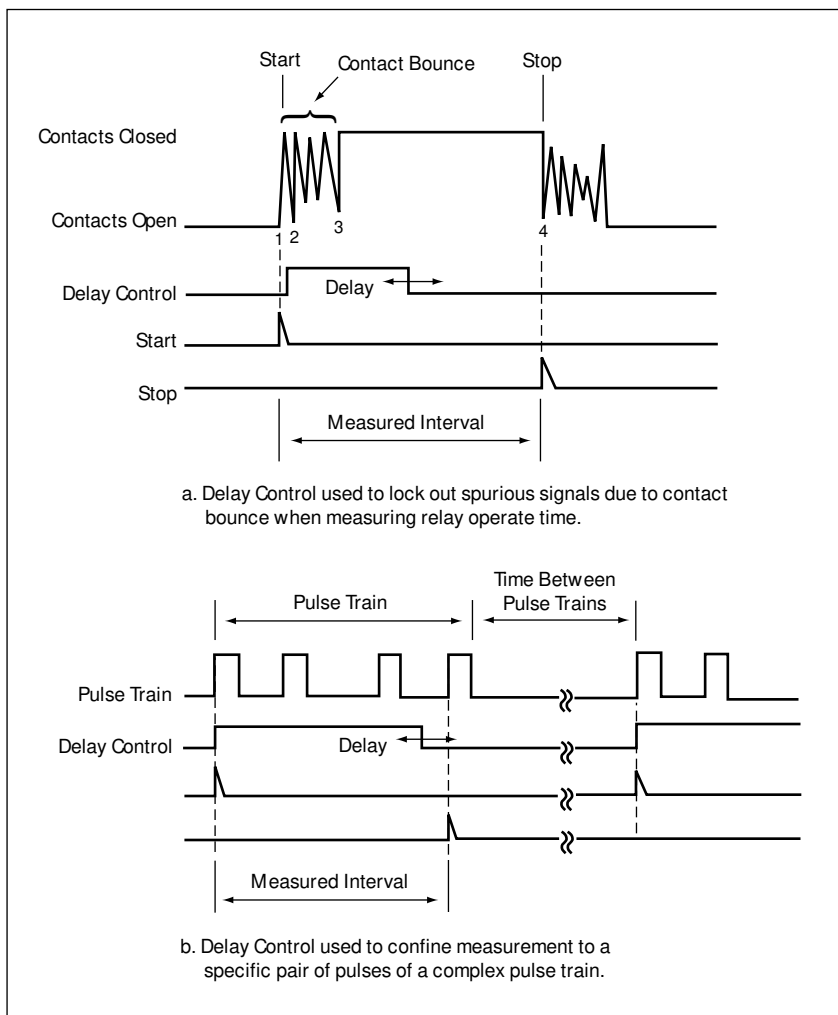

**Figure 22. Using the DELAY Control in Time Interval Measurements.**

## Time Interval Averaging

On a repetitive signal, time interval averaging increases the resolution with which a time interval measurement can be made. Also, depending on the design of the averaging circuits, this technique may extend the minimum measurable interval to less than the period of the counter clock.

### Reduce +1 OR –1 Count Error by $\sqrt{N}$ on Repetitive Signals

The basis of time interval averaging is the statistical reduction of the random +1 or –1 count error inherent in digital measurements. As more and more intervals are averaged, the measurement will tend toward the true value of the unknown time interval but only if the  $\pm 1$  count error is random. The word “random” is significant. For time interval averaging to work the time interval must (1) be repetitive; and, (2) have a repetition frequency which is asynchronous to the instrument’s clock.

Under these conditions the resolution of the measurement is increased by the factor:

$$\frac{\pm 1 \text{ count}}{\sqrt{N}}$$

Where N = the number of independent time intervals averaged

$\sqrt{N}$  defines the improvement in resolution with TI averaging.

When doing time interval averaging the number of digits actually displayed by the counter increases directly as the number of intervals averaged, i.e., 10 averages display one additional digit, 10000 averages display four additional digits, etc. This can be confusing to the operator since the improvement in resolution of the measurement with averaging is only as the  $\sqrt{N}$  i.e., by 3 or by 100 for the example above. The displayed digits beyond this are random numbers therefore completely useless. The HP 5345A Electronic Counter has a display position switch which can be set to eliminate these useless digits to reduce operator confusion. Modern microprocessor controlled instruments like the HP 5370A and HP 5315A automatically truncate unwanted digits.

### Time Interval Averaging is Useful When

- +1 count or –1 count error from a single time interval measurement significantly degrades the accuracy or resolution of a time interval measurement; and,
- The input signal has superimposed noise or jitters.

For Example:

If the width of a repetitive pulse is approximately 1  $\mu$ s, the +1 count or -1 count error in a pulse width measurement using conventional one-shot techniques is 100 ns, 10 ns, or 2 ns (the period of the counter's clock). This error is a large part of the time interval; however, averaging  $10^4$  time intervals can produce 1 ns or better resolution. True time interval averaging is achieved only when the signal repetition rate is not coherent with the counter clock as the time relationship between the signal and the counter clock must be such as to sweep through the full range of the 0 to -1 or 0 to +1 count ambiguity in a random manner to satisfy the statistical requirement of averaging.

If the clock and the input become coherent the system behaves as a sampling system so no improvement whatsoever is had by averaging. The HP 5345A and the HP 5328A Option 040 both achieve true time interval averaging by using a patented noise modulated clock for all TI averaging measurements. This frees the operator from repetition rate considerations.

With averaging, resolution of a time interval measurement is limited only by the noise inherent in the instrument. A typical figure of 50 picoseconds resolution can be obtained with good low noise design.

## **Synchronizers Needed for True TI Averaging**

Synchronizer circuits are necessary in the counter start-stop channels when doing time interval averaging, these circuits insure that the counter gate does not receive partial pulses as this would bias the displayed answer away from the true value in an unpredictable manner.

The synchronizers operate as in Figure 23. The top waveshape shows a repetitive time interval which is asynchronous to the square wave clock. When these signals are applied to the main gate, an output similar to the third waveform results. Note that much of this output results in transitions of shorter duration than the clock pulses. Decade counter assemblies designed to count at the clock frequency dislike accepting pulses of shorter duration than the clock. The counts accumulated in the DCAs will therefore approximate those shown in the fourth trace — the exact number of counts is indeterminate since the number of short duration pulses actually counted by the DCAs cannot be known. Since the time interval to be measured is slightly greater than the clock period, the fourth waveshape shows that the average answer will be in error, having been biased, usually low, because of the DCAs requirement of having a full clock pulse to be counted.

This problem is alleviated by the synchronizers which are designed to detect leading edges of the clock pulses that occur while the gate is open. The waveshape applied to the DCAs, when synchronizers are used, is shown by the fifth waveform. The leading edges are detected and reconstructed, such that the pulses applied to the DCAs are of the same duration as the clock.

Synchronizers are a necessary part of time interval averaging; without them the averaged answer is biased even though the reading appears to settle down to a stable number. In addition, with synchronizers involved, the counter can be designed to make time interval measurements of much less than the period of the clock. This technique is only as good as the synchronizers, however, high-speed synchronizers can enable intervals as small as 100 picoseconds to be measured, even though the clock period might be 100 nsec for example.

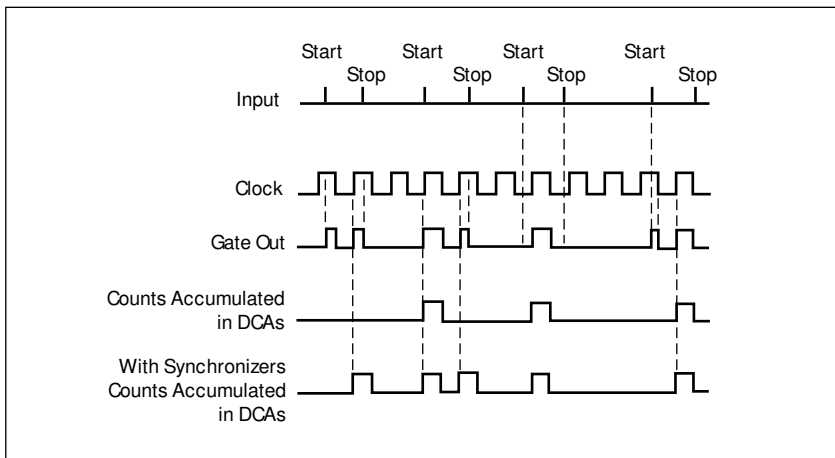

**Figure 23.**  
Synchronizer  
operation with  
time interval  
averaging.

## Extending Time Interval Measurements to Zero Time

This technique is used with the HP 5328A, HP 5308A, HP 5326A/B, and HP 5327A/B Counters to extend minimum TI average measurements down to the nanosecond or sub-nanosecond region. The main disadvantages of the synchronizer system used with these counters is that the time between a stop pulse and the next pulse must always be longer than the clock period, and multiple stop pulses can lead to incorrect readings.

The HP 5345A uses a different synchronizer approach so it will not make time interval average measurements below 10 nanoseconds. It can make a measurement of 10 ns wide pulses spaced as close as 10 ns (50 MHz rate).

The 10 ns minimum time interval is not a serious limitation as it can always be circumvented by adding an additional 10 ns delay (approx-

mately 200 centimeters of RG-58/U cable) in stop (B) channel input. The added delay can be measured as in Figure 24 after which it can be subtracted from all subsequent measurements using the same interconnecting cables. The HP 5363B probe box already has this delay capability which can be adjusted to 10.0 ns in a way that includes all of the system differential delays as well. Application Note 162-1, Time Interval Averaging, Hewlett-Packard Co., discusses TI averaging in detail.

### Disadvantages of Time Interval Averaging

- Requires repetitive pulses.
- Is not useful for statistical measurements such as rms jitter or histograms as the averaging process destroys the very information which is sought.
- Takes a long time to make the measurement for low repetition rate time intervals.

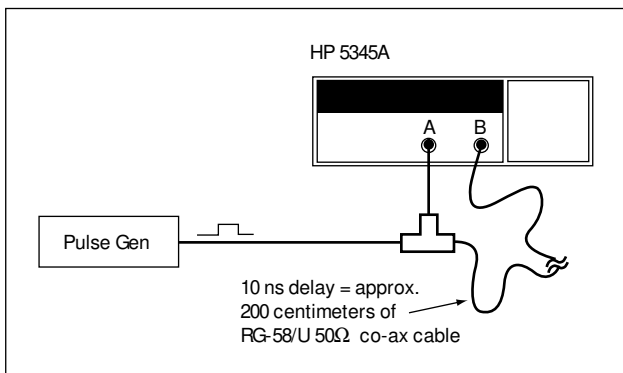

**Figure 24.**  
Extending  
Time Interval  
measurements  
to Zero time by  
adding additional  
delay in the stop  
channel.

## Time Interval Error Evaluation

Total counter error in a time interval measurement is made up of several parts all added together in a way to get the largest number thus defining maximum measurement error. These are:

- $\pm 1$  count
- $\pm$  trigger error (including trigger settability)
- $\pm$  time base error
- $\pm$  systematic error (when measuring short intervals)

### +1 Count Error or -1 Count Error

As for any measurement made with an electronic counter a +1 count or a -1 count ambiguity can exist in the least significant digit of a time interval measurement. This comes about because the digitized internal counted clock frequency and the input Start/Stop signals are not coherent in the usual measuring situation. The counter has no way of interpolating fractional clock pulses if a Start or Stop falls between clock pulses so the measurement could be off by as much as +1 or -1 clock period. For a 500 MHz clock,  $\pm 1$  count represents  $\pm 2$  ns; for a 100 MHz clock  $\pm 10$  ns, etc. One exception is the HP 5370A counter which uses a digital interpolation scheme to give theoretical resolution of  $\pm 20$  ps.

The  $\pm 1$  count error becomes more significant on short time interval measurements where the total number of displayed digits is only 2, 3, or 4 — as when making rise time or narrow pulse measurements — since this fixed error becomes a more significant part of a short interval. For one-shot measurements this 1 count error determines the ultimate resolution of the counter.

The 1 count error can be reduced by  $\sqrt{N}$  by doing time interval averaging ( $N$  = number of intervals averaged) if the input signal is repetitive.

Time interval averaging depends on the random occurrence of the +1 count or -1 count error so will not work if the internal clock of the counter and the input signal are coherent. The HP 5345A and the HP 5328A Option 040 both have patented noise modulated clocks so the operator need not worry about coherence.

### $\pm$ Trigger Error

Trigger error occurs when the counter does not trigger at the expected voltage level on the input signal. This may be due to:

Noise or distortion.

- On the input signal.
- Added to the signal after it enters the counter.

Drifting of the trigger voltage point of either channel with temperature change, line voltage change, or component aging.

Energy effect on fast rise signals.

### 1. Noise on Input Signal

Triggering is set to occur at +1 volt on the input signal as shown at Figure 25a.

Low frequency noise on the input signal can cause triggering to occur too early (Figure 25b) or too late (Figure 25c). High frequency noise can cause early triggering only.

Noise can occur on either the Start or Stop pulse or both, consequently the measurement may be either too long or too short by twice the error shown in the example.

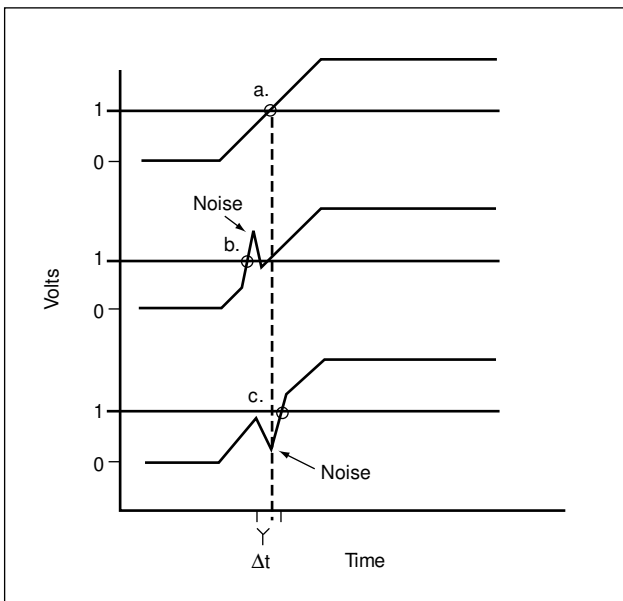

**Figure 25. Time Error introduced by noise on the input signal.**

### 2. Distortion on Input Signal

Figure 26 shows how harmonically related noise as well as nonharmonically related noise moves the trigger point in time. Also shown is the effect of noise on a signal.

### 3. Increased Signal Amplitude Reduces Time Error

Increasing signal amplitude reduces the time error  $\Delta t$  if the high amplitude signal does not have any more noise than the lower amplitude signal. In practical applications this is often the case as noise is frequently due to ground loops or to other spurious signals

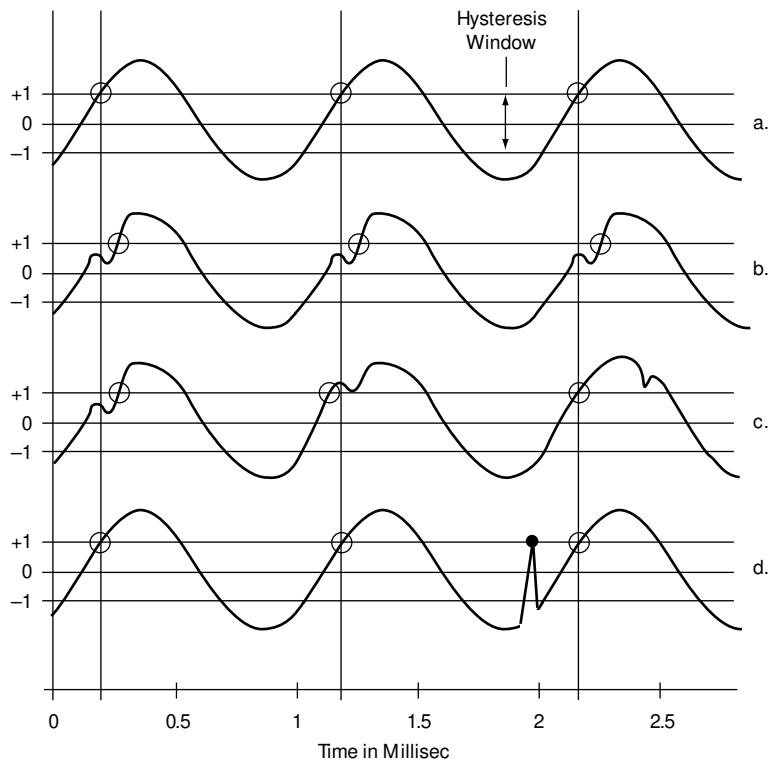

NOTES:

1000 Hz signal.

Circuit set to trigger on a positive slope at +1 Volt. (Hysteresis window is 2 volts peak-to-peak centered on 0 volts dc.) Circles denote actual trigger points.

- a. Triggering on a low distortion sine wave signal. Trigger points, identified by circles, occur at the same relative point time wise on each cycle.
- b. Sine wave with harmonic distortion. Trigger points are displaced in time (but not voltage) from waveform "a" however they are consistent from cycle to cycle. Only one output pulse per cycle occurs unless the distortion voltage becomes large enough to cross both hysteresis limits. Depending on the measurement, harmonic distortion on the input signal may or may not introduce an error.
- c. Sine wave with nonharmonically related distortion. Trigger points can occur early or late depending on the distortion and are not consistent in time from cycle to cycle. Nonharmonically related distortion of the input signal usually introduces errors into a measurement.
- d. Sine wave with noise. Since noise is random, the trigger point may occur anywhere with respect to the sine wave signal. Note particularly that improper triggering is caused by the voltage of the noise signal crossing the trigger level. In the case of a narrow spike on a low frequency sine wave, distortion may seem insignificant when measured with a distortion analyzer that looks at average voltage or power. Only a peak reading voltmeter or oscilloscope will give the necessary information when looking for this kind of error.\*

\*When using an oscilloscope to examine a signal for noise pulses, the bandwidth of the oscilloscope must be compatible with the resolution of the counter being used for the measurement. For example, when using an HP 5328A Counter one must examine the input signal for noise pulses as narrow as 5 nanoseconds as the counter will resolve these narrow pulses even if the input signal frequency is as low as a hundred Hertz or less. The HP 5345A will resolve 2 ns so a 500 MHz oscilloscope is needed when looking for noise pulses.

**Figure 26. Effect of Harmonic Distortion or non-harmonic distortion and noise on the time a measurement begins or ends.**

whose amplitude is relatively constant regardless of the level of the desired signal. In general, the higher the amplitude of the input signal on any given attenuator setting the smaller the error due to noise. Amplitude cannot be increased indefinitely, however, as ultimately the input overload protection circuits of the counter come into play. The protection circuits may completely distort the measurement and give erroneous readings under heavy overload.

With sine wave inputs in particular, increased amplitude is helpful as the slope of the signal through the hysteresis window increases as in Figure 27. Triggering should occur near the center of the sine wave if possible as slope is steeper here.

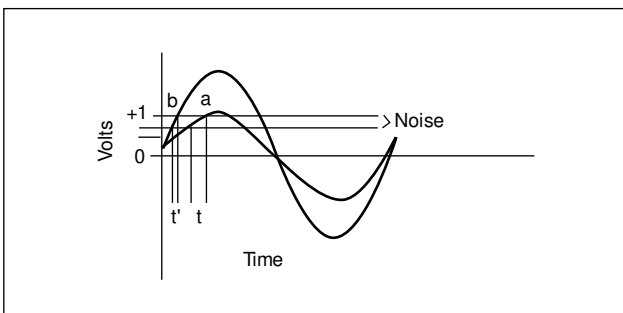

**Figure 27.**  
Increased signal amplitude reduces time error.

Triggering at zero volts on an ac coupled symmetrical signal, Figure 14, makes the trigger point timewise independent of the amplitude of the signal. Triggering near either peak of a sine wave should be avoided as the low slope both before and after the peak gives rise to large trigger error. By the same token if the input signal has infinitely fast rise time (theoretical only) it would make no difference where on the waveform triggering occurs as there is zero time difference between the voltage levels in Figure 28.

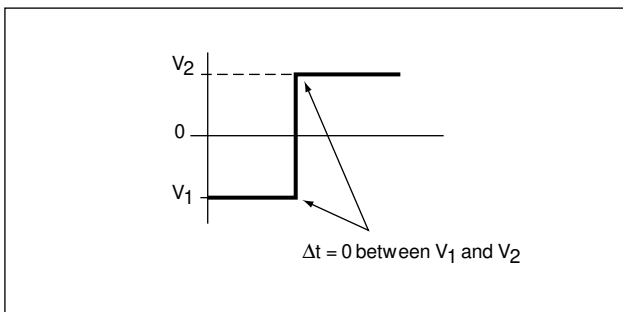

**Figure 28.**  
Trigger time is essentially the same regardless of trigger voltage for an input signal with infinitely fast rise time.

Often a time interval measurement is made from a point on one signal to a corresponding point on another signal. For this measurement the location of the trigger points is not important so long as Start and Stop are at corresponding points on the input signal. When possible, the trigger point should be located where the rate of change of voltage is greatest as the time error is then at a minimum for a given amplitude of noise voltage as indicated in Figure 29.

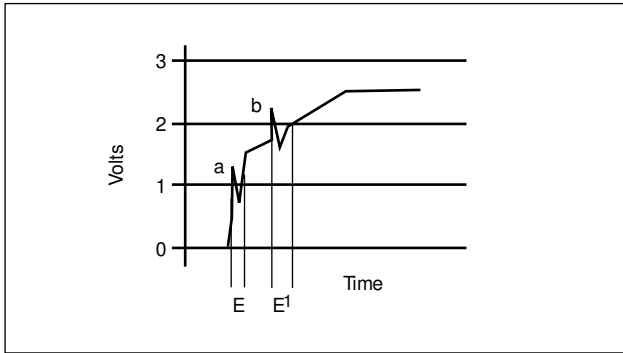

**Figure 29. The same amplitude noise pulse gives a smaller error (E) on a fast rise signal (a) than on a slow rise signal (b).**

#### 4. Calculation of Trigger Error Due to Noise or Distortion

Two expressions are used to evaluate the trigger error in a time interval measurement, one is for sine wave inputs and the other for pulse inputs. The general error expression is derived as follows. See Figure 30.

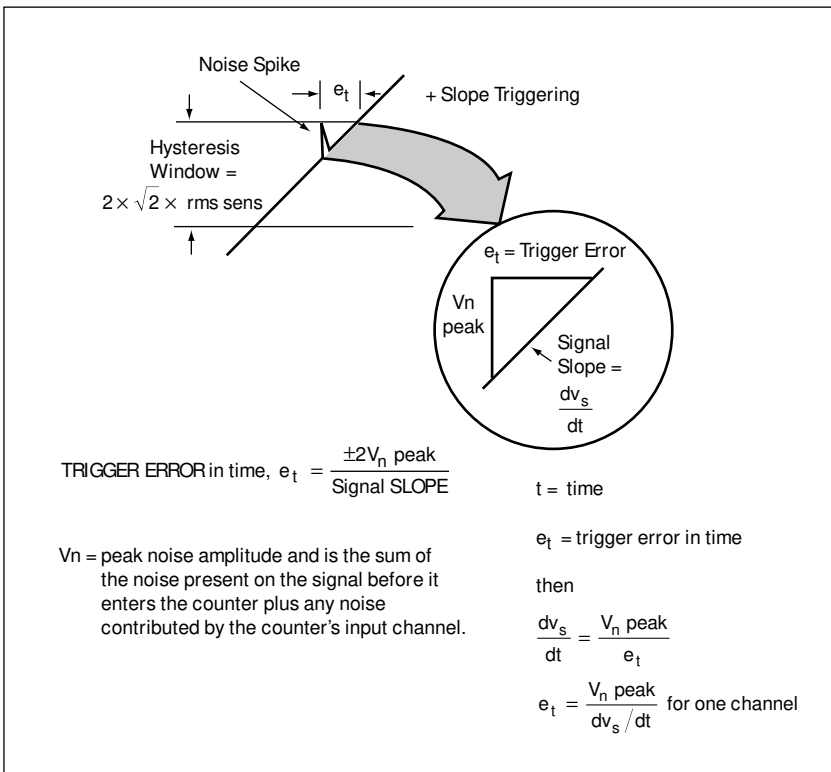

**Figure 30. Trigger error derivation**

A factor of  $\pm 2$  is included to account for both the start channel and stop channel errors and a  $\pm$  sign takes into account the fact that the gate may open or close early or late.

## 5. Trigger Error Due to Input Amplifier Noise

The effective rms noise contributed to the total noise by the counter's input is not usually specified and in many cases has been negligible. However, as sophisticated applications for counters increase, the noise contribution should be specified. For example, in the HP 5315A this noise component is specified as 80  $\mu\text{v}$  rms over the bandwidth of the counter.

## 6. Trigger Error for Sinewave Input Signals

$$\text{Signal} = v_s \text{ peak} \sin 2\pi ft = v_s$$

$$\frac{dv_s}{dt} = 2\pi f v_s \text{ peak} \cos 2\pi ft$$

Slope is max at center of waveform where  $\cos 2\pi ft = 1$

$$\left. \frac{dv_s}{dt} \right|_{\text{max}} = 2\pi f v_s \text{ peak}$$

Substituting in the general error equation developed earlier

$$\text{TRIGGER ERROR } e_t = \pm \frac{2V_n \text{ peak}}{2\pi f v_s \text{ peak}}$$

for 40 dB signal to noise ratio (amplitude, not power)

$$\frac{V_n \text{ peak}}{v_s \text{ peak}} = 0.01$$

$$\text{TRIGGER ERROR} = \frac{\pm 2}{2\pi f} \times \frac{V_n \text{ peak}}{v_s \text{ peak}} = \frac{\pm 2(0.01)}{2\pi f} = \pm \frac{0.003}{f}$$

where  $T = \text{period of signal}$

$$\text{Fractional time error} = \frac{\Delta T}{T} = \frac{e_t}{T} = \pm \frac{0.003}{\frac{f}{T}} = 0.3\%$$

For noise 40 dB down (peak voltage-wise) from the signal. This is the expression most often seen in both the period and time interval accuracy specifications. This derivation places no requirement on input signal amplitude; however, it does assume triggering at a maximum slope, therefore, the peak input signal must exceed the actual hysteresis window by about 30% or more for sine wave signals to satisfy this requirement. Trigger error can be greater by a factor of 10 when triggering at or near either peak of a sinewave signal. Reducing the distortion on the input signal reduces this error somewhat but not as much as expected because noise introduced internally by the input circuits becomes significant when input distortion is down by 50 dB or more.

## 7. Trigger Error Expression for Pulses

$$\text{TRIGGER ERROR IN TIME, } e_t = \pm \left( \frac{V_n \text{ peak}}{\text{Signal Slope}_{\text{Start Channel}}} + \frac{V_n \text{ peak}}{\text{Signal Slope}_{\text{Stop Channel}}} \right)$$

For a counter with 100 mVrms sensitivity the hysteresis window =  
 $100 \text{ mV} \times 2.82 = 282 \text{ mV}$

For a 40 dB (amplitude) signal to noise ratio the peak-to-peak noise  
 for a 100 mVrms signal is 2.82 mV and peak noise is 1.41 mV.

Therefore:

$$\text{Trigger error, } e_t, \text{ for one channel} = \frac{(1.41 \text{ mV})}{\text{Signal Slope}} = \frac{0.00141 \text{ Volt}}{\text{Signal Slope}}$$

$$\text{TOTAL TIME INTERVAL ERROR} \approx \pm \frac{0.00141}{\text{Signal Slope of start channel}} \pm \frac{0.00141}{\text{Signal Slope of stop channel}}$$

where signal slope is in volts per unit time

This derivation does depend on the input sensitivity of the counter  
 (100 mVrms used for this example) so the expression will be  
 different for counters with other input sensitivities. Start channel  
 slope and noise and stop channel slope and noise may not be the  
 same so must be evaluated individually for each channel.

## 8. Combining the Effect of Input Signal and Counter Contributed Noise

The rms noise associated with a single trigger is

$$\frac{\sqrt{X^2 + e_n^2}}{\text{Input slew rate at trigger point}}$$

where X = effective rms noise of the counters input channel  
 (= 80  $\mu\text{V}$  for the HP 5314A and HP 5315A)

$e_n$  = rms noise voltage of the input signal measured over a band-  
 width equal to the counter's bandwidth.

Since for time interval measurements trigger error occurs at both  
 the start and stop signals and the noise adds on an rms basis, the  
 rms trigger error for time interval measurements is

$$\frac{1.4 \sqrt{X^2 + e_n^2}}{\text{Input slew rate at trigger point}} \text{ s rms}$$

In most cases, the dominant noise component is contributed by the input signal. If the input signal is especially “quiet” the input amplifiers become a consideration. The fast slew rates of modern logic greatly reduce the effect of noise errors and in many practical cases these can be neglected.

## 9. Energy Effect

In addition to the previously discussed factors which contribute to the trigger point time error, the so called “energy effect” is also a factor to consider when measuring intervals of a microsecond or less. This effect although always present is small enough so it is generally overshadowed by noise and other factors when measuring longer intervals. The energy effect comes about because the input voltage must remain beyond the selected trigger voltage point long enough to transfer a finite amount of change, represented by the shaded area of Figure 31 into the trigger circuit to activate it. The amount of change necessary to initiate triggering is a function of both the input amplifier-trigger sensitivity and the circuit bandwidth so may be different for each model of counter. Due to this effect, the counter always triggers at a higher voltage (or lower depending on selected slope) than selected so in all cases the measurement begins or ends later in time than expected.

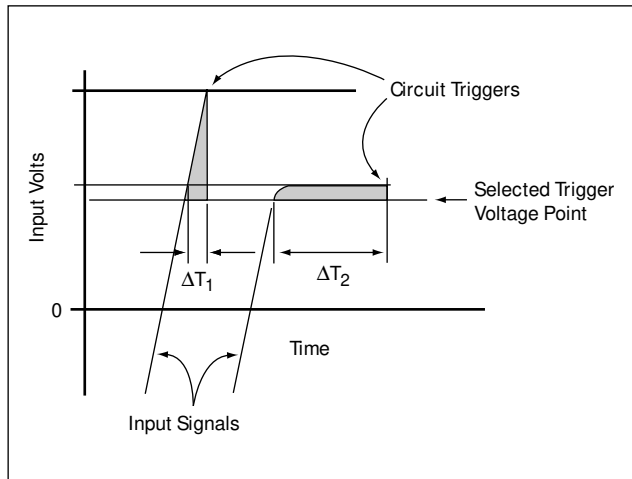

**Figure 31.** Energy effect introduces time error  $\Delta T$  which can be significant on short TI measurement if signal does not extend well beyond the selected trigger point.

The time error due to “energy effect” can be minimized by selecting trigger points well within the maximum excursion of the signal. For the HP 5363B Time Interval Probes the specification requires the signal to go beyond the selected trigger voltage point by at least 100 millivolts or the trigger voltage selected must be below the peak by 8% or more of the peak-to-peak input voltage.

The energy effect error is negligible for long time intervals and when triggering the start and stop channel at the same voltage point on input signals with identical risetime and amplitude as when making phase measurements. It does, however, require careful consideration

when making risetime measurements on fast pulses as this calls for setting one trigger voltage point near one extreme and the other near the opposite extreme of the input signal.

This discussion points up the need for identical start and stop channels when making sophisticated TI measurements on fast signals. All circuits introduce some delay, but if start channel and stop channel delays are equal, the accuracy of the measurement is unaffected even though displaced in time. Identical amplifiers are most apt to satisfy this requirement. Amplifiers with different bandwidths will introduce error as the internal time constants are longer, hence propagation delay is greater for low frequency amplifiers.

### **± Time Base Error**

Crystal oscillator (clock) accuracy is seldom of consequence in practical time interval measurements. Most electronic counters have quartz oscillators with accuracy of a part in  $10^6$  (1 part per million) or better. As a result, the effect of oscillator stability does not affect a time interval measurement unless the display has 5 or 6 valid digits of information. While it is possible to measure long intervals with high resolution, most practical measurements today are rise time of fast signals, propagation time through high-speed logic or on narrow pulses. Resolving a 5  $\mu$ sec interval to 1 nanosecond entails only 4 digits of information — i.e., 5000 nanoseconds — so an oscillator as poor as 1 part in a million introduces only 1/200 as much error as  $\pm 1$  count for this measurement. For shorter intervals the oscillator error is proportionally less.

Time interval averaging increases the number of valid digits, but here again usually not to the extent that crystal accuracy is important. Short term stability may become important when doing time interval averaging on narrow pulses. The short term stability specification is statistical in nature so is worse for short averaging times. Consider for example a short term accuracy specification of  $1 \times 10^{-9}$  for a 1 second averaging time. This would be  $1 \times 10^{-3}$  for a 1 sec averaging time (5 nanosec for the example above) and would be greater for an oscillator with poorer short term stability.

Aging rate is generally of consequence only in an application where the counter is used to make phase or time measurements to compare high precision frequency standards. In this application a counter is used to measure the time variations between once per second time ticks from the two different frequency standards. Each time interval measurement may be as long as one second ( $1 \times 10^6 \mu$ sec) on frequencies that are stable 5 parts in  $10^{12}$  or better so a stable crystal oscillator is needed.

## ± Systematic Error

These fixed errors introduced by interconnecting cables, trigger level settings and similar parameters introduce errors which are essentially constant for any given measurement configuration. Since these errors are relatively constant they are of importance only when making absolute measurements of width, delay, etc., and do not enter in when looking for changes in the measured parameter as an experiment progresses. Particularly on short intervals, the difference in delay due to propagation time on both the interconnecting cables as well as through the start and stop channel circuits may no longer be insignificant. This differential delay must either be adjusted out or taken into consideration when making absolute measurements. This error is usually small so that it need not be considered when making measurements longer than 10 microseconds or so. Signal propagation time is about 0.052 nanosecond/centimeter (19.2 cm/ns) for polyethylene insulated RG 58 A/U 50 ohm coax cable, therefore cable lengths must be matched for the start and stop channels or the measurement may be in error. In most measurement situations, the use of equal length cables cancels out this error; however, cable delay varies with the dielectric constant of the insulation so cables of the same kind should be used. Where this is not practical, the electrical lengths of the cables can be measured by the counter to determine a correction factor to apply to the counter reading. Application Note 174-10, *Measuring Electrical Length (Delay) of Cables*, discusses this measurement in detail.

Just as with other measuring instruments looking at fast rise input signals, one must also consider the fact that the loading introduced by connecting the timer interval counter may actually change the shape of the input signal. The resistive component of loading is usually high enough so as not to be troublesome, rather it is the input capacity of the counter and of the interconnecting cables that accounts for the loading. The HP 5363B Time Interval Probes box reduces this loading as far as feasible for a general purpose instrument.

# Time Intervals by Digital Interpolation

## Digital Interpolation

Another technique for improving resolution is by interpolation which is a method of directly resolving the  $\pm 1$  count inherent in digital counting schemes. A principle advantage of interpolation over averaging is that the technique does not depend on a repetitive signal for high resolution. In the HP 5370A the interpolation scheme provides 20 ps single shot resolution. If this is compared to a conventional scheme where cycles of the internal time base are counted, it is the equivalent resolution that would be achieved by using a 50 GHz clock. Such clock frequencies are, of course, well beyond the present state of the art.

Another advantage of interpolation is that the high single shot resolution allows the collection of meaningful statistical information. Important characteristics concerning time intervals like max., min., standard deviation may be collected in addition to the mean. If fast data collection facilities are available full histographical information may be obtained. In many time interval measurement situations, these statistical properties are of prime importance. For example, in a digital communication system where jitter is an important consideration, the standard deviation gives an excellent indication of this.

## Phase-Startable Phase-Lockable Oscillators (PSPLO)

Precision digital interpolation schemes are based on phase-startable-phase lockable oscillators (See HP Journal, August 1978). These oscillators have two essential characteristics

- 1) When triggered oscillation will start, virtually instantaneously, and with a fixed phase relationship to the external trigger pulse.
- 2) Once oscillating the stability of the frequency is preserved by phase locking to a stable source such as a quartz oscillator.

## The Dual Vernier Method

A precision dual vernier method of interpolation similar to that used in the HP 5370A is shown in Figure 32. This system uses phase startable phase lockable oscillators in both the start and stop channels. These oscillators have a slightly longer period of oscillation than the reference oscillator such that once started, they will reach coincidence with the reference oscillator some number of cycles later dependent on the initial phase. If the reference oscillator period is  $T_0$  then the start and stop oscillators have periods equal to  $T_0 + T_0/N$  where  $N$  is the interpolation factor. From the diagram, it can be seen that the required time interval  $T$  may be evaluated as follows:

$$\begin{aligned} T &= T_1 - T_2 + T_3 \\ &= T_0 (N_0 + (1 + 1/N) (N_1 - N_2)) \end{aligned}$$

where  $N_1$  = Number of start oscillator pulses to coincidence

$N_2$  = Number of Stop oscillator pulses to coincidence

$N_0$  = Number of reference oscillator pulses between start and stop is incidence.

In the HP 5370A the reference oscillator has a period of 5 ns and the start and stop oscillators have periods equal to

$$(5 \text{ ns} + 5 \text{ ns}/256) = 5 \left( 1 + \frac{1}{256} \right) \text{ ns} .$$

This allows time to be resolved to  $5/256 \text{ ns} \cong 20 \text{ ps}$ .

A practical limitation on the interpolation factor N is imposed by the inherent noise in the counter's input and other circuitry. If the typical noise jitter is say 35 ps rms, there is little advantage to be gained by having an interpolation factor capable of giving resolutions substantially better than this. Furthermore, the coincidence detection between the interpolators and the reference clock would need to be done with a correspondingly high time discrimination. This also imposes a practical limitation. The dual oscillator scheme described above will operate regardless of whether the start or stop oscillator commenced first. In the HP 5370A if the stop signal arrives first, the time interval is given a negative sign.

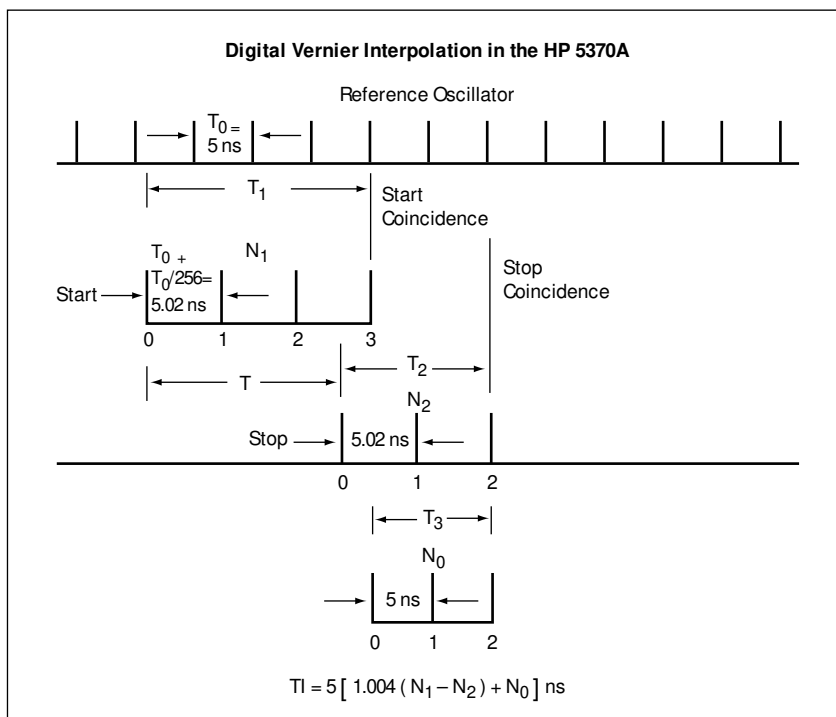

**Figure 32. Digital Interpolation Scheme using phase-startable phase-lockable oscillators.**

# The Generation of Precise Time Intervals

## Phase-Startable Phase-Lockable Oscillators

Phase-startable phase-lockable oscillators (PSPLO) as described in the foregoing section may also be used for the generation of very precise digital delays as in the HP 5359A Time Synthesizer. Here the output from the PSPLO is counted digitally in a preset counter to generate a very precise delay. An important benefit derived from using PSPLOs is that the phase with which the delay commences being synthesized has a constant relationship to an external trigger signal. By contrast, a more conventional scheme would involve interrupting an internal clock train at some random phase resulting in a time interval being generated which is subject to + or - one period variation of the clock.

A simplified block diagram of the HP 5359A and the timing relationship between pulses is shown in Figure 33.

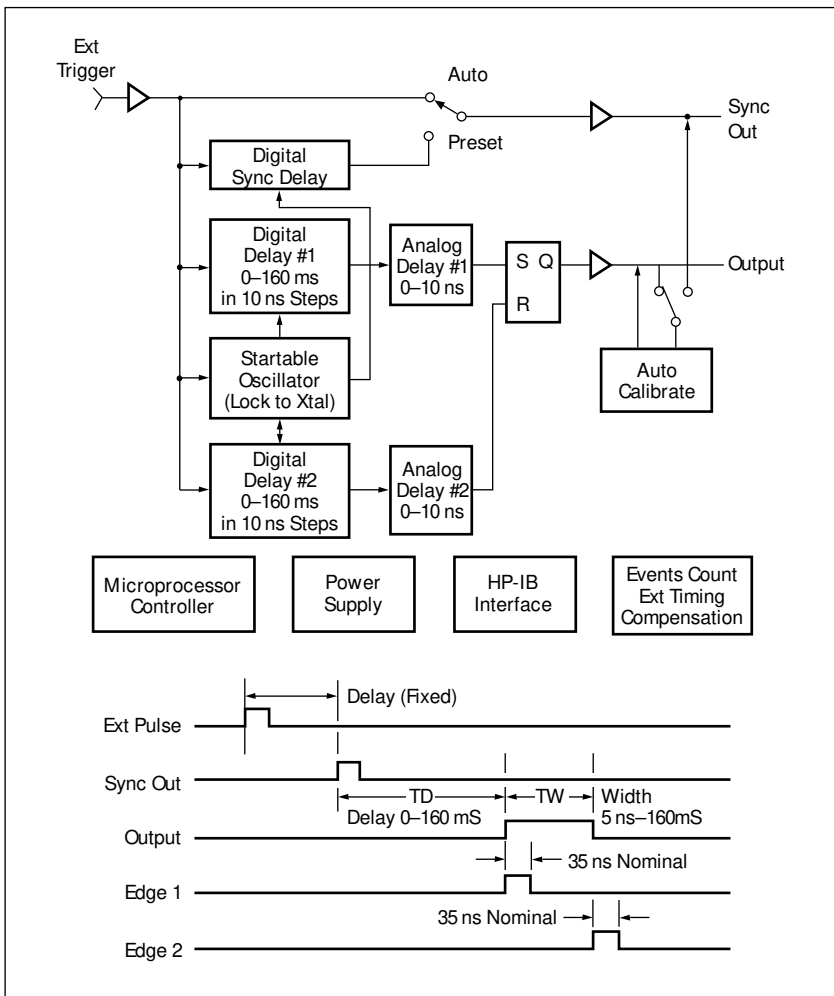

**Figure 33. Block Diagram for the HP 5359A Time Synthesizer showing timing relationships between output pulses.**

Here the digital delay #1 determines the time from the sync output pulse to the output ( $T_D$ ) and digital delay #2, which causes the SR flip flop to be reset, determines the width of the output pulse. Both digital delays which operate with 10 ns resolution are followed by analog delays which provide resolution from 0 to 10 ns. An interesting feature of the delay scheme is the auto calibrate facility which calibrates the delays including the analog portion back to a reference crystal oscillator. Since the instrument contains a microprocessor, any variations can be automatically compensated for. This scheme allows generation of time intervals with sub-nanosecond repeatability even at large delays of up to 150 ms.

The instrument is useful as a calibration source in Radar and other navigation systems. For example, the sync output could be used to simulate the send pulse, and the output which is precisely controllable in time could be used to simulate the return pulse corresponding to a certain range.

The instrument also has many general purpose laboratory applications in circuit design where it may be used as an extremely controllable delay line for the investigation of circuit tolerances and race conditions.

# Time Interval Measurement Using the HP 5363B Time Interval Probes

## Solve Troublesome TI Measurement Problems

The HP 5363B Time Interval Probes box, Figure 34, is a signal conditioner which solves the most troublesome problems encountered in making time interval measurements using an electronic counter:\*



Figure 34.  
HP 5363B Time  
Interval Probes

### 1. By reducing circuit loading.

High impedance, low capacitance, active probes let the operator transport the measurement point to the circuit under test. This keeps circuit loading to a minimum as the usual interconnecting cables are no longer required for the input signal. This is particularly important when working with pulses on other than 50 ohm systems.

### 2. By accurately defining the trigger voltage point.

A simple calibration procedure after SLOPE selection accurately sets triggering at zero volts and calibrates out the residual offset voltages using digital techniques. Once calibration is completed, the trigger point voltages are accurately determined by digital thumbwheel switch settings.

### 3. By calibrating out differential delay between the start and stop channels.

A second calibration step lets the operator calibrate out all of the differential delays in the system including those in the time interval counter start and stop channels as well as the interconnecting cables. An additional control position on the HP 5363B inserts a fixed 10 ns delay in the stop channel so a counter such as the

\* *Active Probes improve precision of Time Interval measurements,*  
HP Journal, October 1975, Volume 27, Number 2, pp. 11-16.

HP 5345A which requires a minimum of 10 ns between a start pulse and the following stop pulse can be used for measurements down to zero nanoseconds. Figure 35 illustrates this procedure.

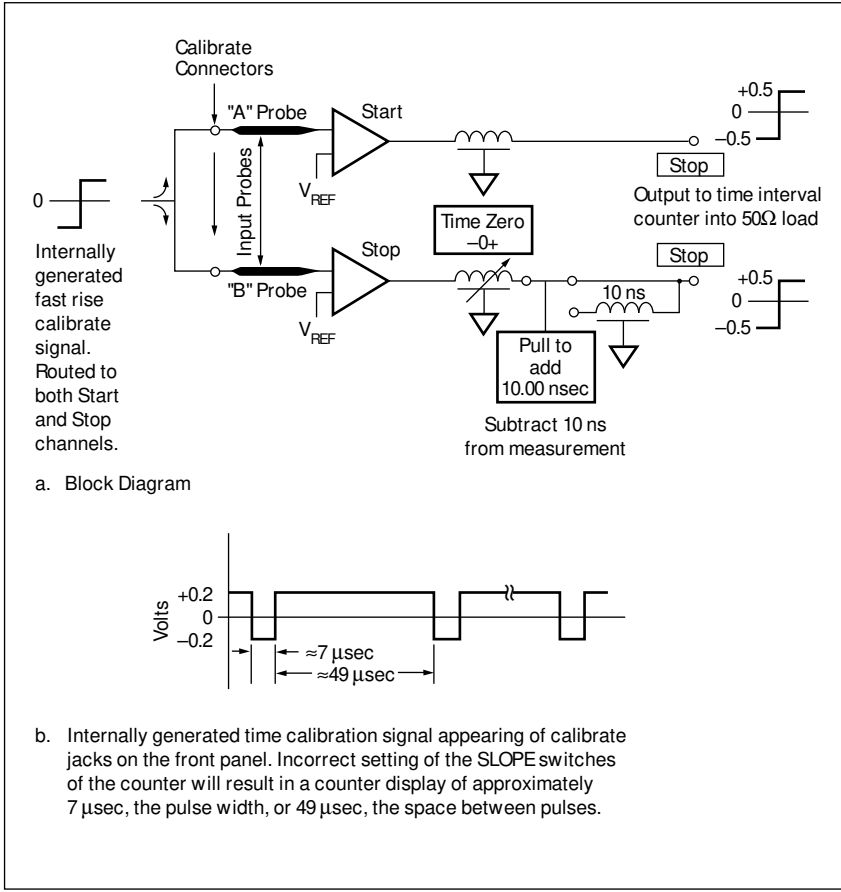

**Figure 35.**  
**Calibrating TIME ZERO of the HP 5363B to compensate for the differential delay between the Start and Stop Panels of the Measuring System.**

4. By offering greater dynamic range than counter inputs.

The start and stop channels of the HP 5363B are designed for all input signals including those with large voltage vs time excursions so will accept signals over the range of -10 volts to +10 volts without sacrificing sensitivity. This is particularly important when triggering from many of the currently used IC logic levels. Logic swings are too large for the X1 range of most counters but sensitivity is sacrificed on the X10 or X20 range.

5. By offering remote programming for system applications.

Option 011 to the HP 5363B provides full remote programming capability including probe selection, SLOPE, POLARITY, LEVEL, and LEVEL CALIBRATION by a controller on the HP Interface Bus. The TIME ZERO control is not bus programmable; however, the differential delay can be measured and software adjusted in a system.

## Level Calibration

1. Depressing the LEVEL CALIBRATION switch first sets both the START LEVEL and STOP LEVEL voltages (normally determined by thumbwheel switches) to zero and grounds the tips of both PROBE A and PROBE B which are inserted in the calibration connectors. Calibration can also be done by grounding the probe tips through 50 ohms or less in systems applications, as it may not be convenient to use the calibration jacks.
2. The HP 5363B employs two DACs (digital to analog converters) for trigger point setting and self calibration.
  - a. The main DAC, controlled by a thumbwheel switch, supplies trigger level voltages settable from +9.99 to -9.99 V in 10 mV steps.
  - b. The offset DAC, used to calibrate out residual offset voltages of the two probes, is initially offset from the main DAC by +75 mV, and covers the range from +75 mV to -75 mV in 1 millivolt steps.
  - c. When calibrating for a positive slope, the LEVEL calibrate switch loads zeros into the main DAC and zeros (represent +75 mV) into the offset DAC.

Internal calibration circuits then scan the offset DAC voltage output which determines  $V_C$  from +75 millivolts downward in 1 millivolt steps until the input channel just switches triggering at zero volts as in Figure 36. This voltage  $V_C$  is stored digitally and added to the digitally selected trigger voltage from the thumbwheel controlled DAC to give a true trigger point voltage with respect to zero volts dc for subsequent measurements.

- d. When calibrating for a negative slope, the process is similar except the offset DAC starts from -75 mV and scans upward.

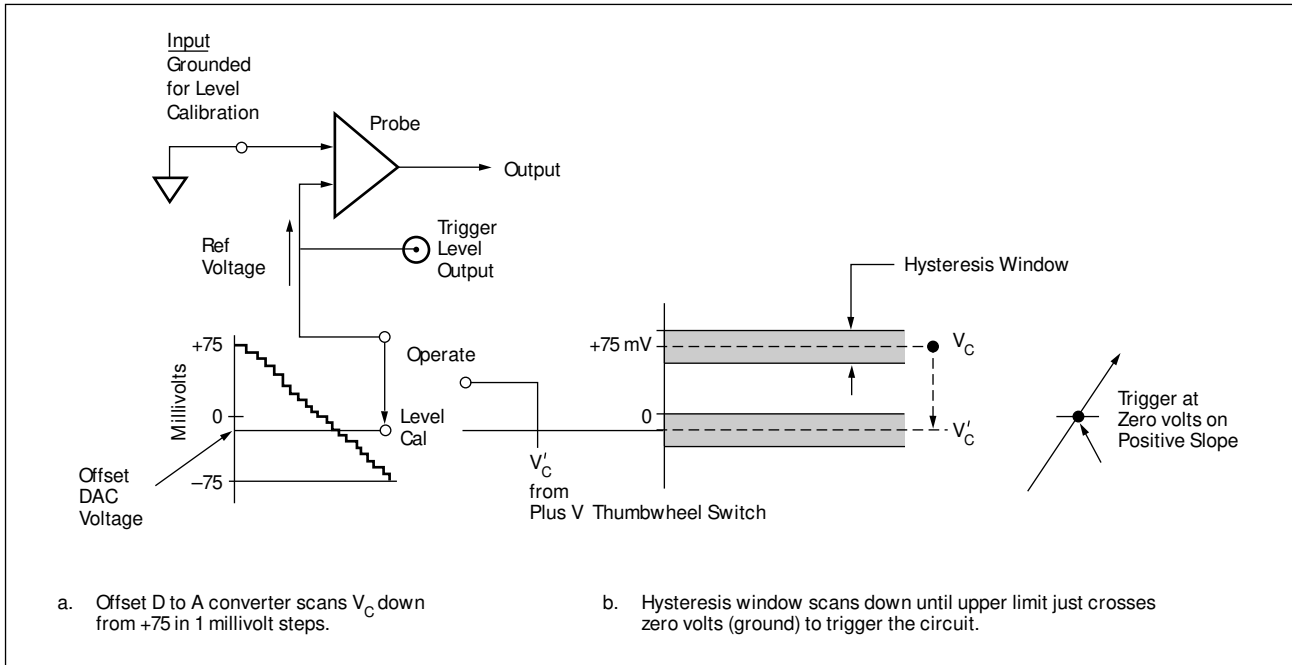

**Figure 36. Level Calibration of one channel of one probe to trigger on a positive slope.**

3. The TRIGGER LEVEL OUTPUT voltage appearing at a rear BNC connector (Figure 37) is the trigger voltage set on a thumbwheel switch plus the calibration voltage supplied to the start or stop channel by the offset DAC. Therefore, this level could be off as much as  $\pm 75$  millivolts (the range of the offset DAC) from the actual trigger voltage. This voltage can be displayed on an oscilloscope along with the input signal to get an approximate idea of the trigger point location as an aid to initial set up. In practice the offset will be much less for an HP 5363B operating in a moderate environment. (Nominal offset voltage is  $-10$  mV to  $-30$  mV at room temperature.) The offset DAC voltage is present at the TRIGGER LEVEL OUTPUT on the rear panel after calibration when the associated thumbwheel LEVEL switch is set 0.00 and can be measured with a dc voltmeter.
4. LEVEL CALIBRATION must be done if the HP 5363B has been turned off or at any time the SLOPE switch or PROBE selector settings are changed or trigger voltage errors as great as  $\pm 75$  mV can occur.
5. An easy way to determine spacing between the hysteresis limits is to go through the normal calibration procedure using a plus slope (  $\nearrow$  ) and measuring the voltage output from the TRIGGER LEVEL OUTPUT connector, then repeat the same procedure with the channel set to trigger on a minus (  $\searrow$  ) slope. The difference between these two voltages is the spacing between the hysteresis limits to within a few millivolts.

## Time Zero Calibration

Figure 35a (page 54) shows how the TIME ZERO calibration is made using an internally generated fast rise signal, Figure 35b. This calibration can also be done by using an external signal with fast transition time ( $>100 \text{ V}/\mu\text{sec}$  slew rate) and setting both channels to the same trigger point (slope and level) preferably near the center of the input transition.

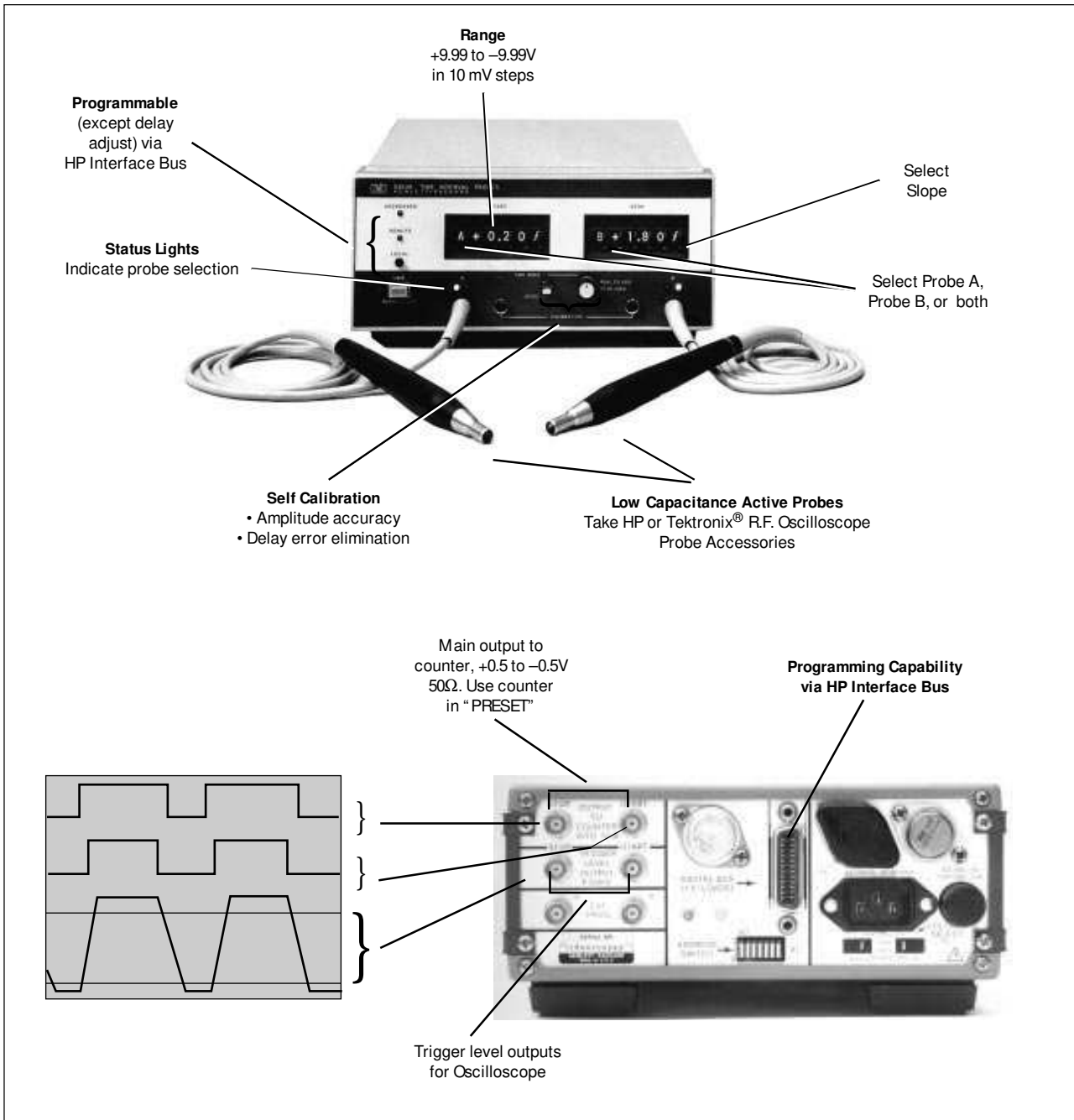
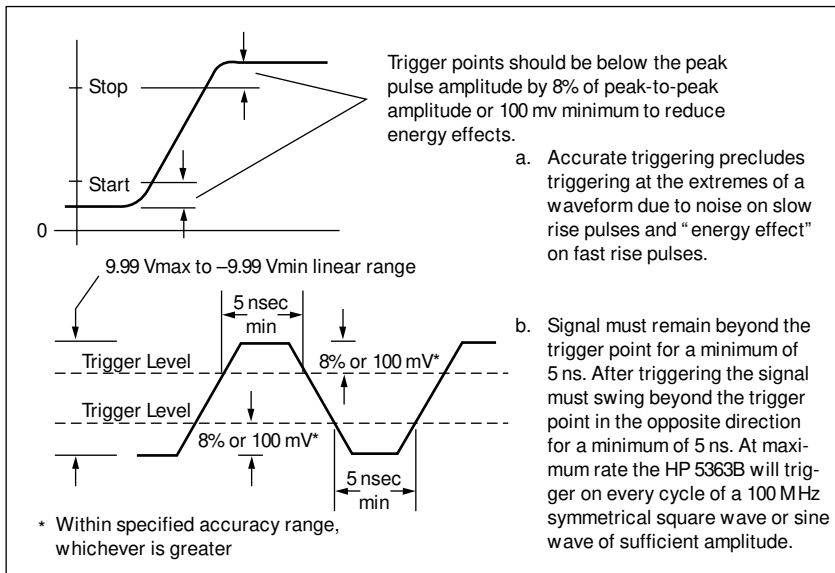

Figure 37. HP 5363B Controls and Connectors

## To Make a TI Measurement Using the HP 5363B

First determine that the signal is within the range of the HP 5363B.

1. Maximum input voltage to the HP 5363B probes without damage is  $\pm 30$  volts dc + peak ac! Minimum pulse width is 5 ns and maximum repetition rate is 10 MHz. Other considerations are discussed in Figure 38. The trigger point is adjustable over a  $\pm 9.999$  volts range in 10 mV steps either by thumbwheel switches or via the HP interface bus using Option 011.



**Figure 38.**  
**Input Signal**  
**requirements for**  
**the HP 5363B.**

### CAUTION

**KEEP PROTECTIVE GROUNDING CAPS ON PROBES WHEN NOT IN USE OR WHEN SHIPPING TO PREVENT DAMAGE FROM STATIC CHARGES.**

2. Set Stop and Start PROBE selectors to A or B, SLOPE  $\nearrow$  or  $\searrow$ , polarity + or - and LEVEL of each channel as required for the measurement of interest. Perform LEVEL calibration as discussed earlier in D.(d).
3. Connect the probe or probes to the input signal and make the measurement.

### NOTE

**Perform LEVEL calibration any time the PROBE selector or SLOPE switches are changed as the offset calibration for the new condition is not made unless this is done. Calibration may not be necessary when measuring high amplitude input signals as maximum trigger voltage error without voltage calibration  $< \pm 100$  millivolts.**

4. Make your measurement with confidence!

# Some Applications of Time Interval Measurement

## Simple Timing System with Start-Stop Pulses Generated by Mechanical Switches

The simplest time interval measuring system consists of a time interval counter, a voltage source, two mechanical switches, and two resistors connected as shown in Figure 39.

Even with this simple circuit of Figure 39 precautions must be taken to get valid measurements.

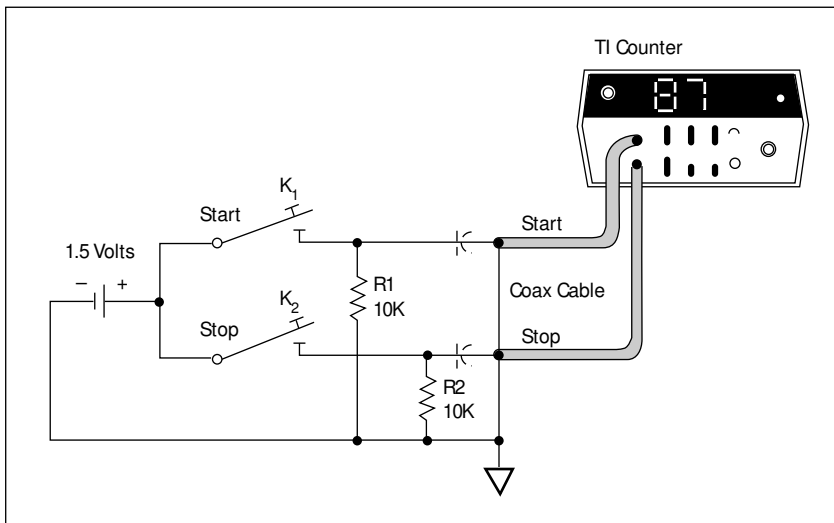

Figure 39. Simple Time Interval measuring System

1. The SEPARATE-COMMON switch on the counter must be set to SEPARATE or both inputs will be tied together internally.
2. The voltage at the counter inputs goes from 0 to +1.5; therefore the LEVEL switches must be out of the PRESET position and set to trigger at about 0.7 volts. The system may work in the PRESET position; however, triggering could be erratic as the operator is depending on noise and overshoot caused by switch operation to generate a signal that will cross the lower hysteresis limit.

Alternately, the inputs may be ac coupled; however in this case, it is vital that resistors R1 and R2 be used. If not, the counter will trigger only once the first time a key is closed but will not trigger on subsequent closings.

This happens because the coupling capacitor (either in the counter or in the external circuit) is initially discharged so it charges and triggers the counter the first time the key is closed. With the key open this charge leaks off very slowly as the only discharge path is via the leakage resistance of the capacitor so discharge may take from minutes to hours depending on the quality of the capacitor. Until this charge is dissipated, the circuit cannot be retriggered. The 10k resistor R1 or R2 insures the coupling capacitor discharges in a small fraction of a second once the key is opened, consequently the input circuit will trigger each time the key is operated.

This system works very nicely using microswitches, telegraph keys, or other mechanical switches to START and STOP the count. Start and Stop must be from separate switches and the counter SEPARATE/COMMON switch must be in SEPARATE for correct operation.

3. This system will generally **not** make a pulse width measurement with the counter set in COMMON (both Start and Stop input connected together internally) and the time interval controls set to Start on a voltage rise (positive slope when the switch is closed) and stop on a voltage fall (negative slope when the switch is opened). It does not work because mechanical switches exhibit contact bounce so the counter displays the time of the first bounce rather than the times the switch was closed. This is discussed under **Delay Control** and illustrated by Figure 22a.

For counters without a built-in delay circuit in the start channel, one can be assembled from a single SN74121 or similar integrated circuit, a 5-volt dc supply, one resistor, and one capacitor. The “on” time of this delay circuit, is made greater than the contact bounce time of the start channel by selecting appropriate values of R and C. A 1- $\mu$ fd capacitor and 10k to 20k resistor gives an “on” time of 10 to 20 milliseconds which is adequate for most mechanical switches or relays. A delay is not needed in the STOP channel as “off” time is controlled by the SAMPLE RATE control on the counter.

This same delay circuit is also needed to count the number of operations of a mechanical switch using a counter in a TOTALIZE mode. Without it, the counter counts and displays each contact bounce as well as each desired operation.

## Phase Measurement

Phase measurement as made with an electronic counter is an important special case of a time interval measurement. First the period a-b is measured, then the Time Interval a-c. From this information phase is calculated using the formula:

$$\text{Phase in degrees} = \frac{t_0}{T} \times 360$$

The general setup as in Figure 40 is the same as for any other time interval measurement; however, several factors must be considered to insure the greatest possible accuracy in phase measurement.

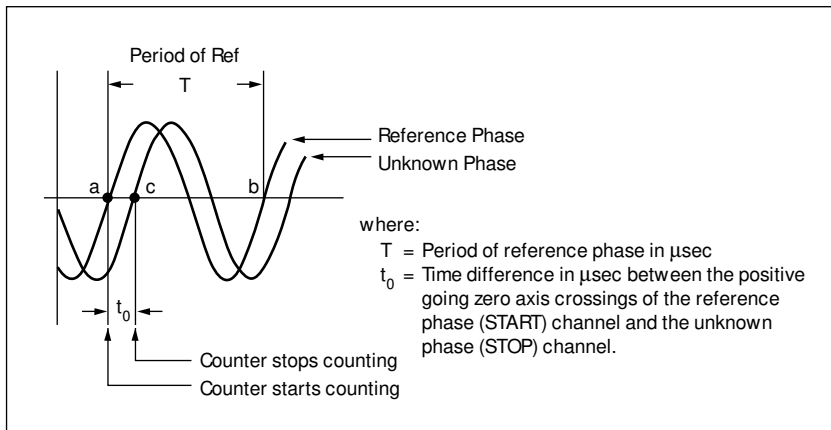

**Figure 40. Phase measurement with a time interval counter.**

1. For any stable phase measurement, the frequency of the reference phase and the unknown phase must be identical.
2. Although a phase measurement could be made between any corresponding points on the two signals this method works only if both signals have the same constant amplitude otherwise the measurement will not yield absolute phase.
3. Set both the START and STOP channels to trigger at zero volts using the procedure of Figure 14 to get absolute phase. Triggering at zero volts also has the added advantage that the phase measurement is independent of input signal amplitude. When triggering at any point other than zero, amplitude variations to either input channel show up as changes in the phase as measured by the counter. The HP 5363A Time Interval Probes are ideal for phase measurement as an internal calibrate procedure plus setting both the START and STOP thumbwheel switches to zero assures triggering at precisely zero volts dc.
4. Measure the time ( $T$ ), Figure 40, by making a period average measurement. A period averaging measurement reduces the trigger error below what it would be if the time interval mode were used since period measurements use the same trigger circuit and consequently the identical trigger voltage point for both Start and Stop.
5. Use the highest input amplitude available provided it does not exceed the internal protective clamp voltages of the counter. A higher amplitude signal increases the slope of the signal at the trigger point (zero volts) and thus reduces trigger error. If clamp voltages are exceeded, however, the counter input impedance changes drastically above the overload point and this distorts the input signal which in turn invalidates the desired time vs. voltage information needed for the measurement.

6. Error evaluation for a phase measurement: The counter accuracy specifications for period average applies to the period T, Figure 41, and the time interval accuracy specification applies to ( $t_0$ ). Phase measurement error is  $\pm$  the sum of these two errors. For most phase measurements, the crystal oscillator accuracy is not important as it is far outweighed by the other factors.
7. Improving resolution and accuracy. The time interval averaging mode can be used to increase accuracy and resolution of a phase measurement for counters that have this mode of operation.
8. Direct Reading Phase Measurements. Counters which can count an external clock while making a TI measurement will display phase directly in degrees if an external clock frequency,  $f_{\text{clock}} = 360 \times f_{\text{ref}}$ , is counted instead of the internal clock oscillator. ( $f_{\text{clock}} = 3600 \times f_{\text{ref}}$  gives  $0.1^\circ$  resolution, etc. The only limiting requirement on the clock frequency,  $f_{\text{clock}}$ , is that it must always be below the maximum frequency the counter will accept at the time base input.)
9. Application Note 174-9, *Making Automatic Phase Measurements (to 1 MHz) With The 5345A Electronic Counter*, has details on manual and on automatic phase measurement using the HP Interface Bus with bus compatible instruments.

## Measuring Complex Pulse Trains

Complex pulse modulation patterns are used by airborne identification and navigation systems. Requirements and specifications on these systems are controlled by the Federal Aviation Agency in the United States.

### 1. ATC (Air Traffic Control) System

The ATC (Air Traffic Control) system is used in conjunction with the ground radar system at an airport to automatically keep track of aircraft in the area.

#### Interrogation Pulse

The ground station sends out an interrogating RF pulse train as shown in Figure 41. This signal is demodulated and analyzed by the on board aircraft transceiver which automatically sends back a coded reply.

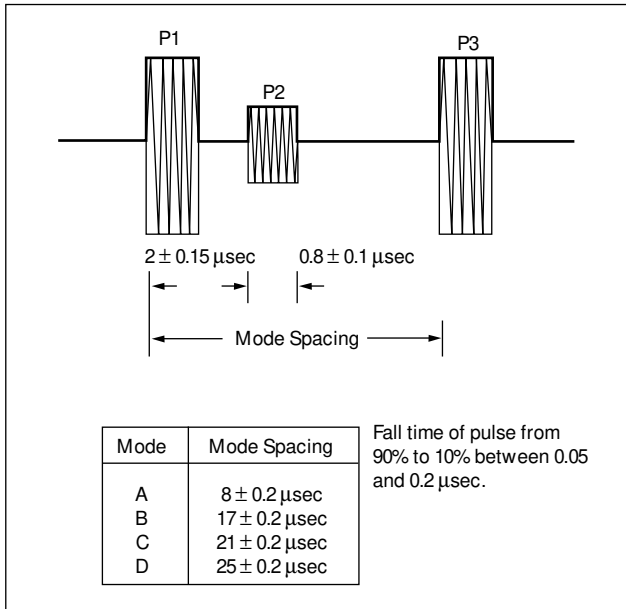

**Figure 41.**  
**Three-pulse ATC**  
**ground station**  
**interrogation.**

### Reply Pulse

When the airborne transponder judges an interrogation to be valid, it replies with a coded signal consisting of from 2 to 15 pulses. The two framing pulses identify an aircraft on the ground radar. With increased air traffic all commercial aircraft and all aircraft flying in congested traffic areas are now required to include automatically encoded altitude information in their reply. Pulse timing for the airborne system is shown in Figure 42.

Some of the tolerances are in the order of 0.5% or better so an electronic counter is an ideal instrument for making these measurements.

An electronic counter can be used to make time measurements on the demodulated ATC pulse train. For the interrogation pulse train, Figure 41, the selection of the start and stop points can be made in terms of amplitude using the LEVEL control of the Stop Channel.

The reply pulse train, Figure 42, is much more complex so a counter such as the HP 5345A (with ET gate control in the time interval mode) is necessary to select the appropriate pair of pulses for the measurement.

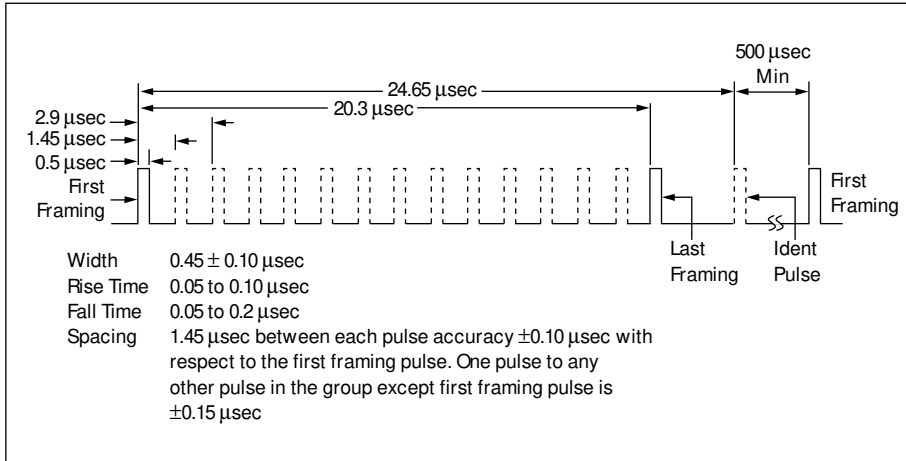

**Figure 42.**  
Available ATC  
reply Pulse codes.

The EXT gate of the counter can be opened at any time following the last pulse of the previous pulse train. The measurement will then begin with the next pulse to occur — in this case, the first framing pulse of the pulse train of interest at (a) in Figure 43.

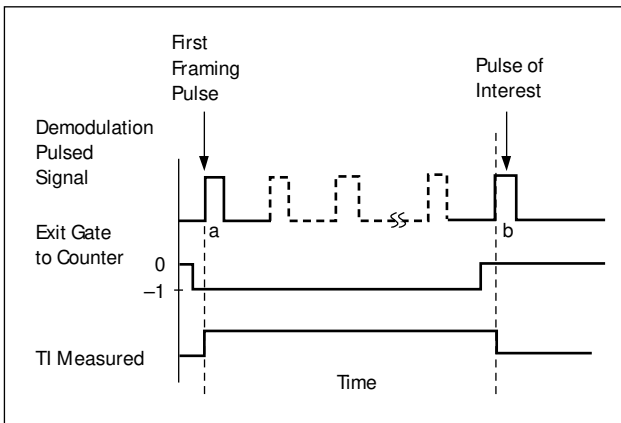

**Figure 43.**  
Making time  
measurements  
on an ATC  
Transponder  
replay pulse  
with the HP5345A  
Counter.

A pulse generator with a variable pulse width (HP 8007A or similar) triggered by the GATE OUT of the HP 5345A is used to select the stop pulse. The counter stops the measurement on the input pulse following the end of the pulse from the pulse generator (-1V to 0V transition). Pulse width setting is not critical as spacing between pulses of the input signal is about one microsecond. A circuit as in Figure 44 can be used to synchronize the measuring system with respect to the first pulse in the complex pulse train shown.

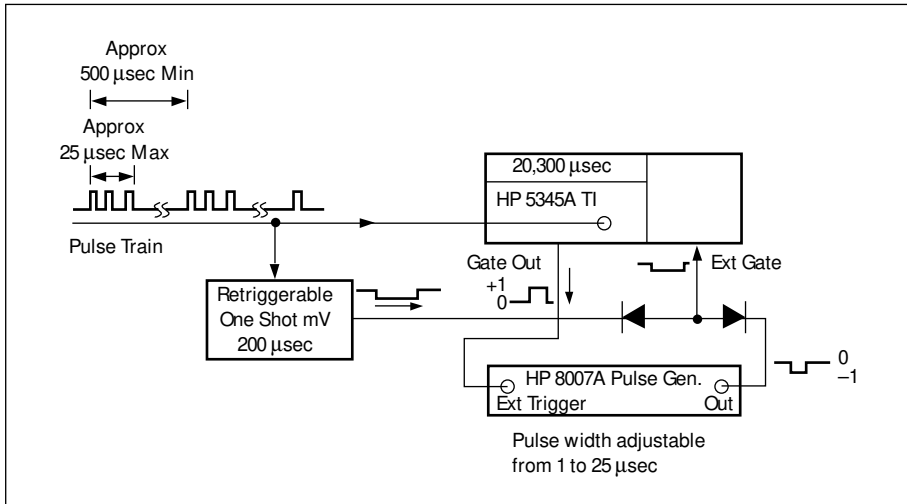

**Figure 44.**  
Synchronizing a complex pulse train with respect to first pulse.

## 2. DME Pulses

The DME, distance measuring equipment, used on commercial aircraft sends out a pair of pulses which trigger a ground based station that sends back a reply.

DME channels are spaced at 1 MHz intervals up around 1 GHz so strict adherence to transmitted pulse shape is necessary to keep adjacent channel energy to a minimum. All of these parameters can be measured on a demodulated DME pulse with a time interval counter and the HP 5363B Time Interval Probes which have digitally set trigger levels.

These examples cite just a few of the applications of time interval measurement to the signals emitted by radar identification, location, and navigational equipment.

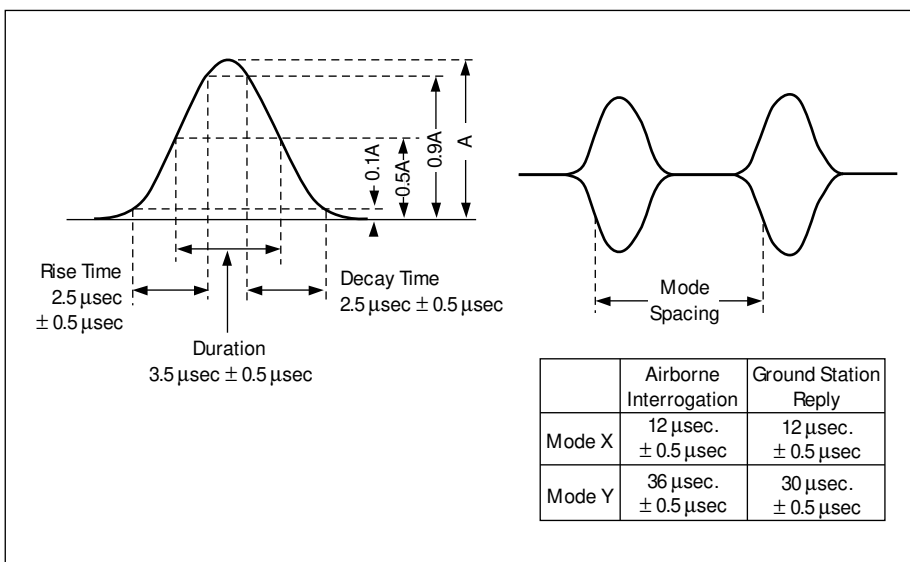

**Figure 45.**  
DME Pulse characteristic

## Comparison with Other Ways of Making Time Interval Measurements on Narrow Pulses or Fast Rise Signals

The oscilloscope was one of the first instruments used for pulse and rise time measurements, and it has been used in that role ever since. Both oscilloscopes and time interval counters have specific advantages in making time interval measurements, and in many cases, the techniques are complementary. In general, time interval counters give greater resolution (0.00000001% on the HP 5370A) on pulse to pulse measurements and can be more readily automated. The oscilloscope gives excellent visual feedback and recently, the introduction of  $\Delta$ time oscilloscopes has made a very real contribution to improving oscilloscope resolution for time interval measurements. For example, the HP 1743A is capable of giving a resolution of 0.002%  $\pm$  1 count. The visual feedback characteristic of the oscilloscopes is important when dealing with noisy or complex waveforms as it allows a skilled operator to concentrate only on the points of interest. If rise times are fast, a time interval counter will not be affected by noise, but in measurements with slow rise time, caution should be exercised.

Interpolating counters give very high single shot resolution which would not be possible on a  $\Delta$ time scope which requires a repetitive signal for operation. In addition, this high single shot resolution of the interpolating allows the collection of statistics.

From the user's viewpoint, the characteristics of the measurement and output required will determine the most acceptable measurement solution. The following summary may help in the selection process.

### Time Interval Counter:

- Highest resolution in pulse to pulse measurements.
- Easy Automation — IEEE 488 Interfacing.
- Statistics.
- Noise effects negligible on fast rise time pulses.
- Single shot capability.
- Different trigger voltages on stop and start channels.
- Measurements above 100 MHz.

### Oscilloscope:

- Excellent visual feedback
- Noisy complex waveforms may be visually filtered.
- Excellent for slow rise time measurements on noisy signals.
- Less prone to false triggering due to noise.

---

For more information about Hewlett-Packard test and measurement products, applications, services and for a current sales office listing, visit our web site, <http://www.hp.com/go/tmdir>. You can also contact one of the following centers and ask for a test and measurement sales representative.

**United States:**

Hewlett-Packard Company  
Test and Measurement Call Center  
P.O. Box 4026  
Englewood, CO 80155-4026  
1 800 452 4844

**Canada:**

Hewlett-Packard Canada Ltd.  
5150 Spectrum Way  
Mississauga, Ontario  
L4W 5G1  
(905) 206-4725

**Europe:**

Hewlett-Packard  
European Marketing Centre  
P.O. Box 999  
1180 AZ Amstelveen  
The Netherlands  
(21 20) 547 9900

**Japan:**

Hewlett-Packard Japan Ltd.  
Measurement Assistance Center  
9-1, Takakura-Cho, Hachioji-Shi,  
Tokyo 192, Japan  
Tel: (81-426) 56-7832  
Fax: (81-426) 56-7840

**Latin America:**

Hewlett-Packard  
Latin American Region Headquarters  
5200 Blue Lagoon Drive  
9th Floor  
Miami, Florida 33126  
U.S.A.  
(305) 267 4245/4220

**Australia/New Zealand:**

Hewlett-Packard Australia Ltd.  
31-41 Joseph Street  
Blackburn, Victoria 3130  
Australia  
1 800 629 485

**Asia Pacific:**

Hewlett-Packard Asia Pacific Ltd.  
17-21/F Shell Tower, Time Square,  
1 Matheson Street, Causeway Bay,  
Hong Kong  
Tel: (852) 2599 7777  
Fax: (852) 2506 9285

**Data Subject to Change  
Printed in U.S.A. June 1997**

**Hewlett-Packard Company  
Copyright © 1997  
5965-7663E**