Fundamentals of Quartz Oscillators

Application Note 200-2

Electronic Counters Series

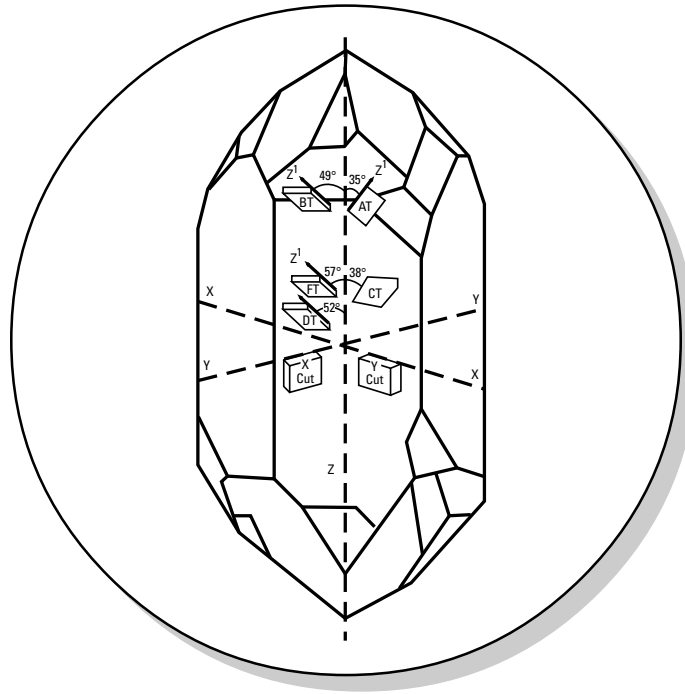

Table of Contents

Introduction	3
Crystal Fundamentals	4
Piezoelectricity	4
Crystal Structure	4
Crystal Cuts	5
Vibration Modes	6
Frequency Determination	7
Crystal Mounting	7
Electrical Equivalent	8
Influences on Crystal Oscillator Frequency	10
Temperature Effects	10
Time	11
Long-Term	11
Short-Term	12
Drive Energy	13
Gravity	13
Shock	14
Vibration	14
Electromagnetic	14
Retrace	14
Typical Performance of Oscillator Compensation Techniques	15
Temperature	16
Time	18
Long-Term	18
Short-Term	19
Line Voltage	19
Warm Up	20
Oscillator Influence on Measurement Accuracy	22
Frequency Counters	22
Frequency Synthesis	23
Appendix A	24
References	25

Introduction

The accuracy of a generated frequency depends upon the reference element selected. The purpose of this note is to provide a background on the crystal reference element and its impact in an oscillator circuit. This information is then used to explain the effects of the oscillator on the accuracy of a frequency measurement and frequency generation.

While there are numerous crystalline substances which have the basic requirements of a reference element, quartz, due to its many desirable characteristics, has become the most widely accepted. A quartz reference element was first used in an oscillator circuit in 1920, some 40 years after the discovery of piezoelectricity. Since that time, improvements have been and are still being made in converting the raw quartz crystal into a usable reference element (Ref. 5). These changes in processes have resulted in the discovery of behavioral changes of the reference element. These behavioral aspects influence the oscillator and as such warrant considerable discussion.

The basic application for the quartz resonator is to connect it in a manner such that the mechanical vibrations stabilize the oscillator's frequency. This is possible since the crystal acts like a tuned circuit when placed in an amplifier feedback arrangement. The electrical equivalent of the quartz plate is shown in Figure 1. When connected into an amplifier circuit, Figure 2, a small amount of energy is fed back to the crystal which causes it to vibrate. These vibrations act to stabilize the generated frequency at the resonate value. It is at this point that the user of this generated frequency must decide upon the usefulness of the source for the application. A detailed look at crystal oscillator fundamentals can help make that decision.

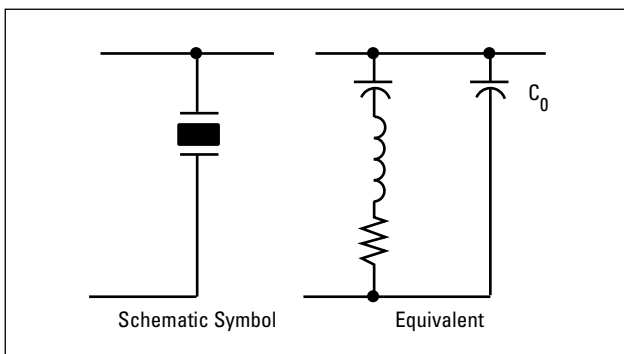

Figure 1.
Equivalent circuit
of a crystal
includes the
capacitances
contributed by the
wire leads and
the holder in C_0 .

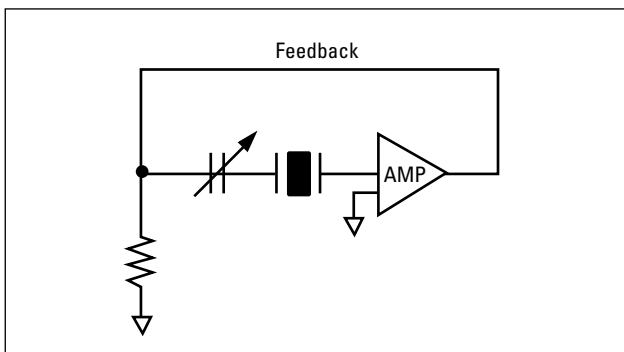

Figure 2.
Simplified
amplifier feedback
(oscillator) circuit
using a crystal
resonator.

Crystal Fundamentals

Piezoelectricity

Piezoelectricity is the primary property of a crystal which makes it usable as a resonator. Piezo is derived from the Greek word piezin and means “to press.” Piezoelectricity as defined by Cady (Ref. 3) is “electric polarization produced by mechanical strain in crystals belonging to certain classes, the polarization being proportional to the strain and changing sign with it.” This electric polarization can be produced by strain such as bending, shear, torsion, tension, and compression on a piece of quartz. The electric polarization provides a source of electromotive force (voltage). Additionally, the inverse effect can be created, i.e., a voltage applied across the crystal produces mechanical movement (Figure 3).

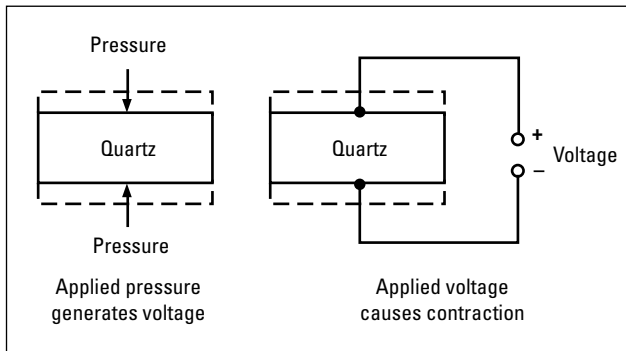

Figure 3.
Piezoelectricity principles.

Crystal Structure

The quartz crystal is formed from silicon and oxygen (SiO_2). Its characteristic form is a result of the unit cells by which the crystal grows. These unit cells are identical and consist of atoms arranged in a repetitive geometric pattern. Quartz crystals have a three dimensional geometric body (Figure 4). Most the physical properties of a crystal are anisotropic (direction dependent), therefore, changes during the growth of the crystal which affect anisotropy result in crystal imperfections. A change in the piezoelectric coefficient, for example, will create a boundary across which the sign of the charge differs when strain is applied. This twin boundary (referred to as twinning) prevents the crystal piece from resonating, making it unsuitable for an oscillator reference unit. Since a considerable amount of work is involved in making a good crystal resonator, these defects should be detected early. Crystal orientation and the presence of defects such as twinning and fractures are detected through the use of polarized light, X-rays, and chemical etching.

The major axis of quartz growth is called the optic axis. This axis is not anisotropic to light, therefore light passes readily. For the purpose of cutting pieces of quartz to act as resonators, the optic axis is labeled the Z axis in an orthogonal X, Y, Z coordinate system. A quartz crystal having 6 sides has three separate X axes and three Y axes definable at 120° increments about the Z axis. The Y axes are perpendicular to the prism faces while the X axes bisect the angles adjacent to the prism faces (Figure 4).

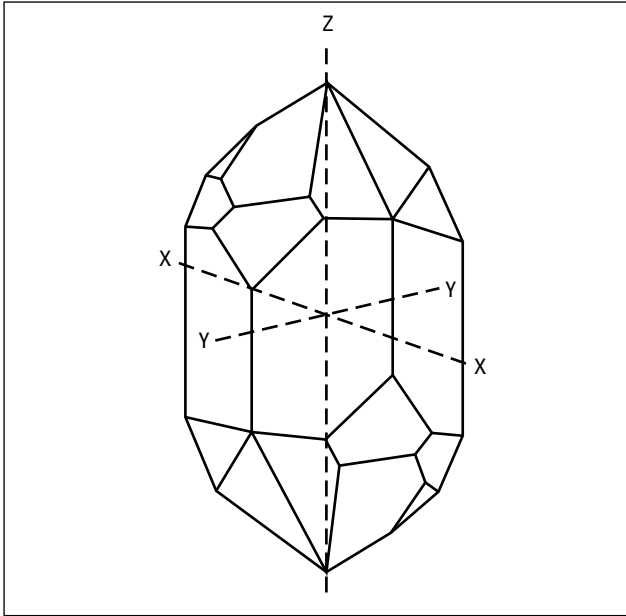

Figure 4. Doubly terminated quartz crystal showing axis orientation.

Crystal Cuts

A small piece of quartz material is obtained by cutting the crystal at specific angles to the various axes. The choice of axis and angles determine the physical and electrical parameters for the resonator. For example, an X plate crystal, one which is cut with its major face normal to the X axis (Figure 5), has a relatively large voltage generated when compressed and decreases in frequency with temperature increases. A similar voltage can be generated by a pure shear stress on a Y cut plate. The Y cut, however, exhibits a positive temperature coefficient. Numerous other cuts can be made simply by changing the angle and the axis of reference.

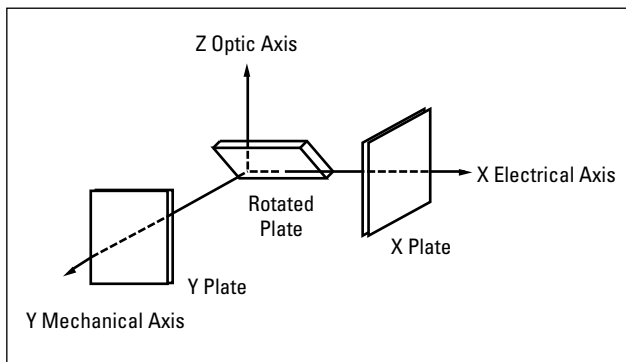

Figure 5. A description of the axis of quartz and X, Y, and rotated plates.

Figure 6 shows combinations of X, Y, and Z rotational cuts which are arbitrarily labeled such as AT, BT, etc. These more common cuts provide for various trade-offs between electrical-mechanical capability and temperature coefficient.

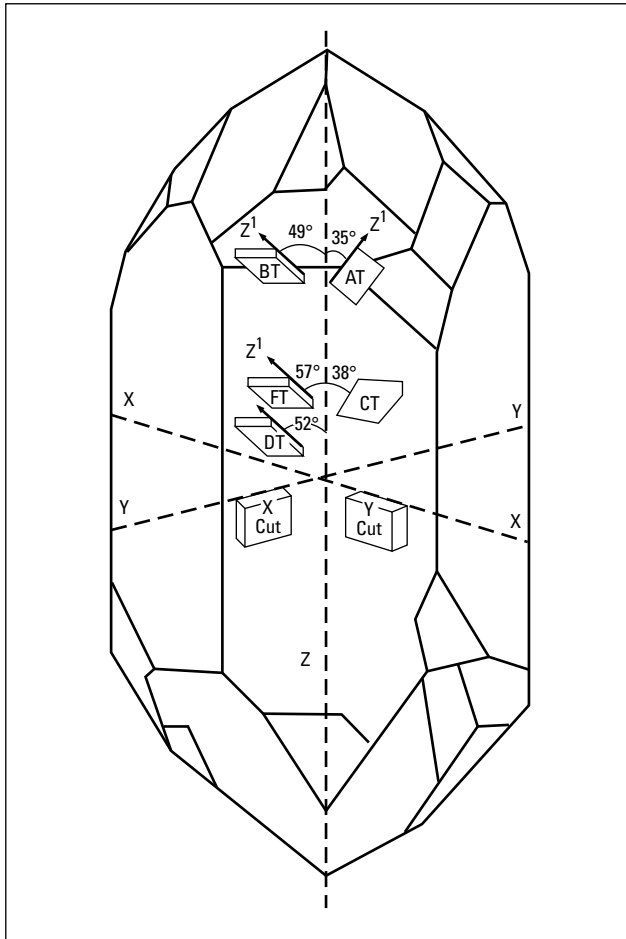

Figure 6. Typical crystal cuts from a doubly terminated quartz crystal.

Vibration Modes

When a piece of crystal is subjected to a voltage, a stress is produced. If the voltage is caused to alternate at the proper rate, the crystal will begin vibrating and produce a steady signal. The mode of vibration depends upon the way the crystal was cut, i.e., an X cut exhibits an extensional vibration mode whereas the AT, which is cut at 35 degrees off the Y axis, vibrates in the thickness shear mode. An illustration of the various vibration modes is given in Figure 7. The vibration set-up in the quartz crystal may produce both harmonic and nonharmonic signals and overtones. The harmonic overtones are desirable since they allow the production of higher frequency crystal resonators using essentially the same cut. Nonharmonic overtones, on the other hand, are undesirable as they may lead to the generation of unwanted signals at frequencies spaced close to the one desired. When unwanted signals occur, they could also change with environmental influences. The various vibrations may then cancel, causing the crystal to stop resonating. This phenomenon is termed an activity dip since the crystal activity stops and starts due to a changing environment. Crystals having unwanted signals could also shift from one resonate point to another producing a frequency jump which would be an undesirable effect.

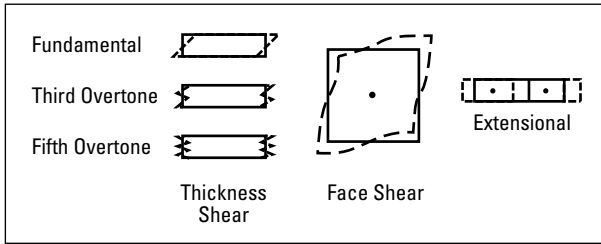

Figure 7.
Vibration modes
of various crystal
cuts and the
thickness shear
overtone.

Frequency Determination

The frequency, or rate of vibration, is determined by the cut, size, and shape of the resonator, e.g., a 10 MHz 5th overtone unit is only 1.2 centimeters in diameter and about 1.06 mm thick. The primary frequency determining factor for the AT and BT cut is thickness since they vibrate in the thickness shear mode. The precision with which the thickness is controlled determines the variation from crystal to crystal from a nominal center frequency. Final adjustment of the center frequency is sometimes accomplished by plating small amounts of gold on to the quartz. A monolayer (one atom thick) of gold can change the frequency by 2 parts in 10^7 . Circular crystals of the thickness shear vibrating mode, when designed with the proper radius of curvature at the center, will produce “clean” frequencies with no spurious tones. It is for this reason that high performance crystal oscillators will typically utilize highly polished and properly shaped quartz resonators. In fact, these crystals are honed to a surface finish which is 10 times finer than used for prescription eye glasses.

Crystal Mounting

The supporting structure and the means used to obtain the electrical contacts is dictated by the vibrating mode. Care must be exercised in mounting to avoid placing a strain on the crystal. The support must not become a part of the resonator since it would absorb energy and could cause an activity dip. A thickness shear mode crystal is supported by the edges at an approximate null or zero node to avoid interfering with the vibration. A typical 1 MHz crystal, due to its size, might be held by tension wires at several points about the surface edge. A 10 MHz unit being smaller could be supported at two points on a ceramic header. Other support types are shown in Figure 8.

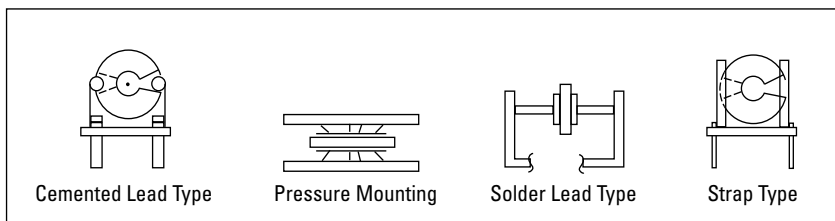

Figure 8. Methods of mounting crystals depending upon cut and application.

Once the crystal is mounted, a suitable encasement is selected. The encasement reduces the effects of contamination, humidity, and atmospheric changes. Glass has been used for many years since it is easy to work when evacuation and inert gas backfill are required. A newer technique is a cold weld copper lid over a ceramic header. This method provides a cleaner environment and allows for uniform heat distribution.

Electrical Equivalent

The electrical equivalent (Figure 9) provides the link between the physical property of the crystal and the area of application, the oscillator.

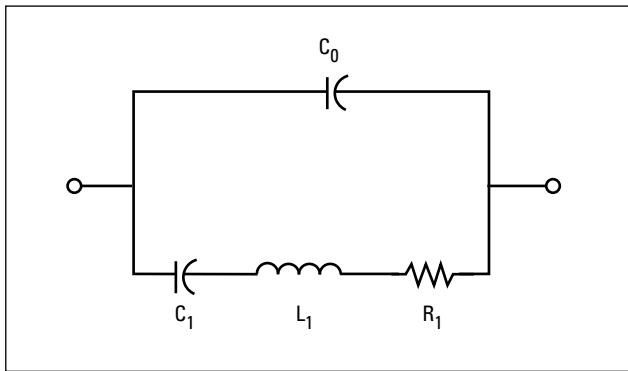

Figure 9. The electrical equivalent circuit for a crystal resonator.

The physical constants of the crystal determine the equivalent values of R_1 , C_1 , L_1 , and C_0 . R_1 is a result of bulk losses, C_1 , the motional capacitance, L_1 is determined by the mass, and C_0 is made up of the electrodes, the holder, and the leads. When operated far off resonance, the structure is simply a capacitor C_0 but, at the precise resonant frequency the circuit becomes a capacitor and resistor in parallel. The reactance of the crystal approaches zero at the point of series resonance and reaches a maximum at the antiresonant frequency f_A (Figure 10).

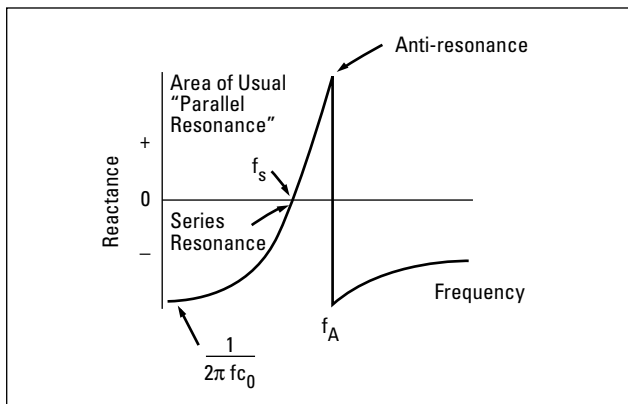

Figure 10. The reactance of the crystal varies with the frequency of operation near resonance.

An area typically chosen for operation of the oscillator is either near series resonance or at the more inductive area of parallel resonance. The series resonant circuit (Figure 11) utilizes the characteristics of the crystal where the reactance is just slightly inductive (above f_s Figure 10). Series capacitance is then added to obtain a tuned circuit. The series capacitor is typically adjustable so that the phase of the feedback can be changed slightly thus fine tuning the oscillator frequency. The parallel resonant mode adds capacity in parallel or across the crystal (Figure 12). This circuit typically operates highest on the reactance curve, hence the crystal reactance is more inductive.

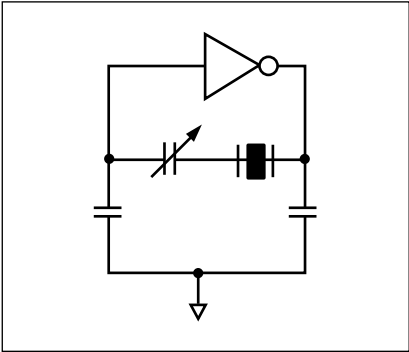

Figure 11. The Series Resonant Oscillator

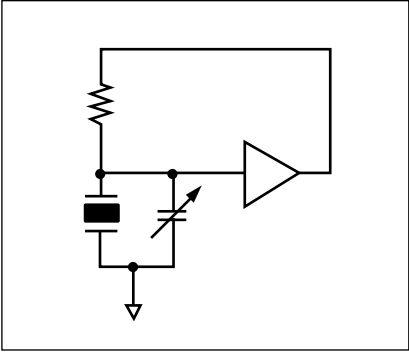

Figure 12. The Parallel Resonant Circuit

Influences on Crystal Oscillator Frequency

The desired result of the crystal and its associated oscillator circuit is a precise frequency. The crystal frequency, however, is determined by the thickness, density, elasticity, molecular changes, and area of resonance over which the quartz plate is operating. Since these factors are influenced by temperature changes, time, drive energy, and other environmental conditions, it is only reasonable to expect that these factors will influence the crystal oscillator frequency.

Temperature Effects

A major influence on the crystal frequency is that of operating over variations in temperature. An oscillator exactly on frequency at 25° Celsius with a frequency variation of 5 parts per million (ppm) per degree Celsius change could experience a frequency offset of 25 ppm with only a 5°C temperature rise. The amount of frequency variation is due to the crystal temperature coefficient, and therefore, depends upon the crystal cut. Graphs of temperature vs frequency for various cuts are given in Figure 13.

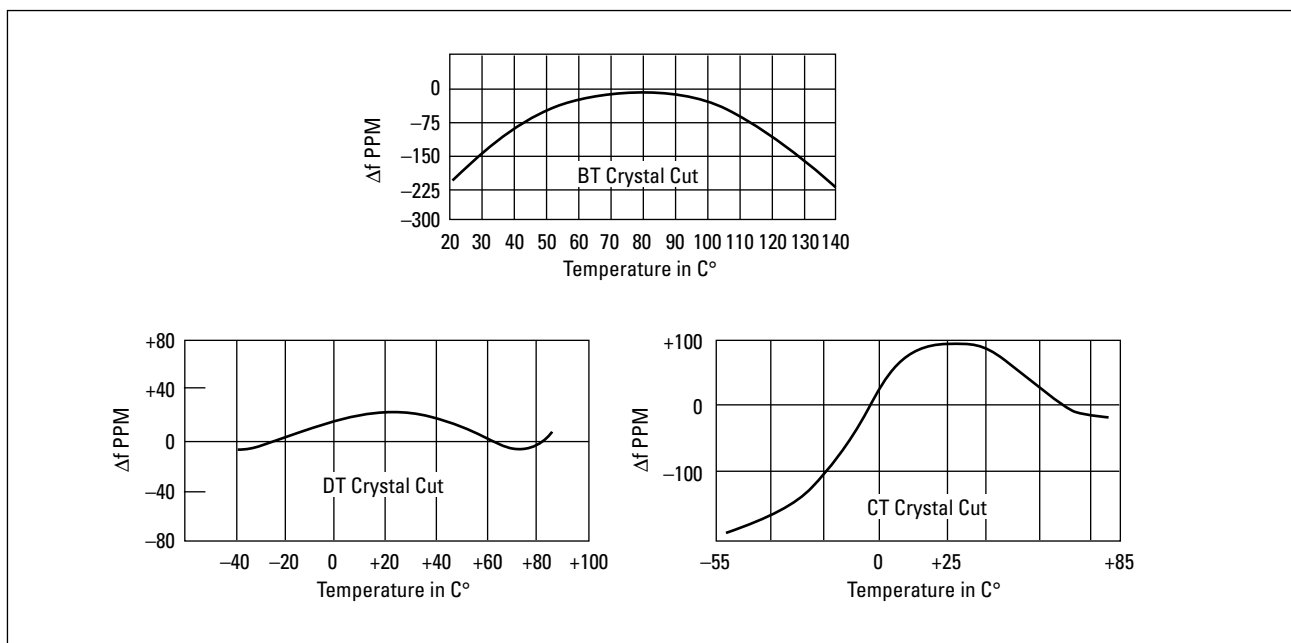

Figure 13. Frequency vs. temperature plots for DT, BT, and CT cuts.

The curves for some crystal cuts remain relatively flat over a limited temperature range. Others have both positive and negative frequency excursions creating an “S” shaped curve. Changing the angle of cut by only a small amount can limit the excursions and make the slope less steep (Figure 14). Obviously, it is not possible to completely avoid these frequency variations if the crystal is to be used over a wide temperature range. Therefore, other techniques must be used to reduce this effect. This subject will be considered in a later section on compensating techniques.

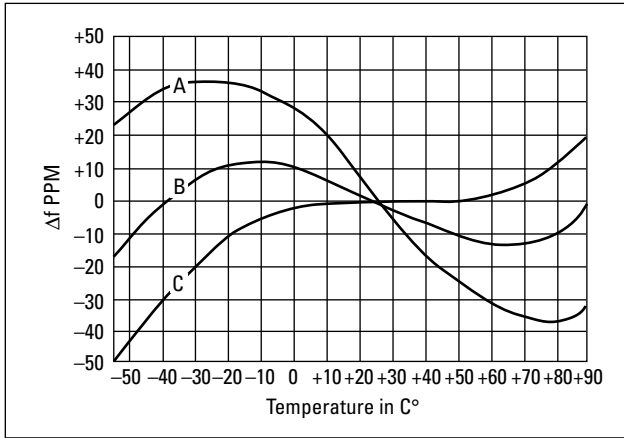

Figure 14.
A, B, and C are
temperature vs.
frequency plots of
AT cuts which
have been varied
by a few seconds
of angle rotation.

Time

Frequency variations relative to time are indicative of oscillator stability. Stability is usually expressed as the fractional frequency change over a period of time, i.e., long-term or short-term.

Long-Term

A gradual change in frequency over days or months is known as aging. This occurs for various reasons, e.g., the physical properties of the crystal mounting may change. The crystal coefficient of elasticity changes when subjected to stress, or when trapped gasses escape, or when contaminants attach to or leave the crystal surface. Aging occurs at a relatively constant rate per decade for each crystal (Figure 15). Therefore, to maintain an accurate frequency, periodic oscillator adjustments must be made to remove the effects. Generally, the frequency of an oscillator can be varied a few cycles by a slight change in the phase of the feedback signal. This change is usually accomplished by an adjustable capacitor. A 10 MHz oscillator with an adjustment range of 20 Hz can be corrected for 75,000 + hours (9 or 10 years) of aging at a 5×10^{-10} per day rate.

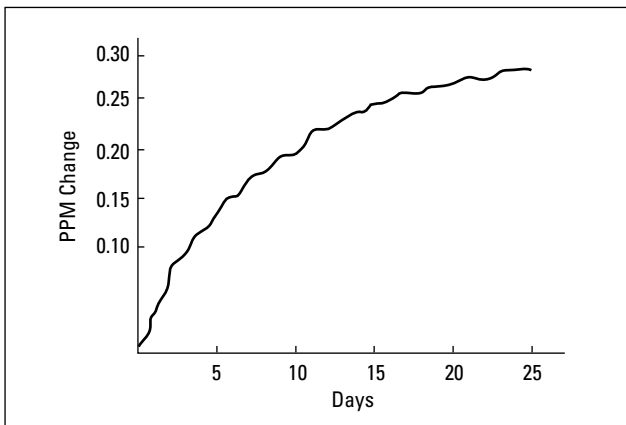

Figure 15. Time
domain stability
of the fractional
frequency change
over time (days)
starting from a
point of
calibration.

Short-Term

Short-term rms frequency variations or time domain stability is a measure of the frequency or phase noise. This is specified as the standard deviation of the fractional frequency fluctuations for a specific averaging time. These small frequency changes are essentially superimposed upon the aging curve (Figure 16).

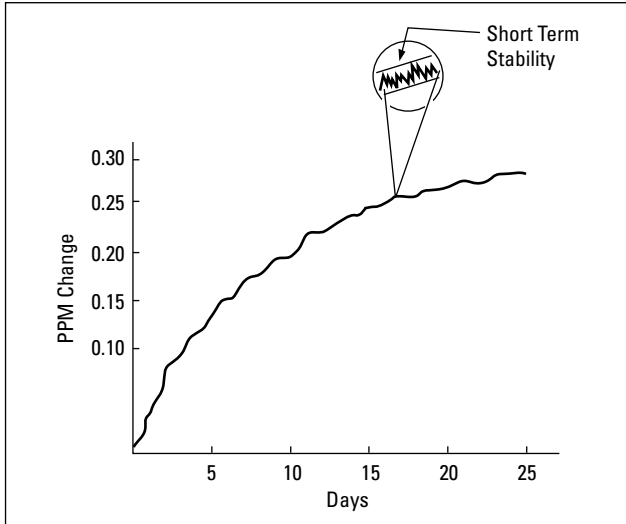

Figure 16. Short-term time domain stability or the fractional frequency change over time (seconds) and its relationship to aging.

Time domain stability is typically specified for a one-second average. Shorter or longer averaging times may be required in the accuracy computation for some applications. The manufacturers of high performance oscillators will usually include measurement from 10^{-4} to 10^2 second averages in power of 10 increments (Figure 17). Time domain stability is related to the frequency domain measurement termed phase

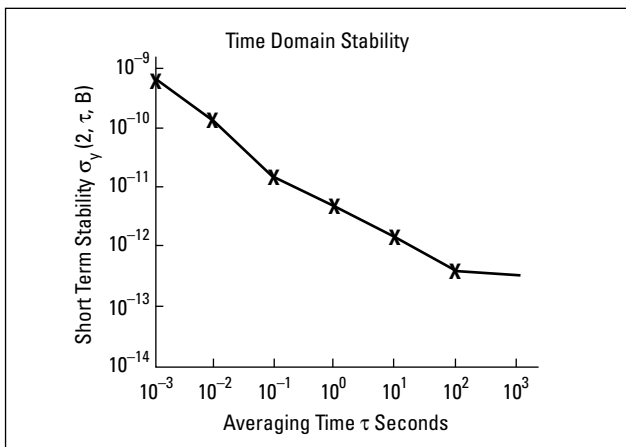

Figure 17. Time domain stability (short-term) for specific averaging times.

spectral density. This measurement is sometimes provided in lieu of the time domain stability. Phase spectral density is related to the signal to single sideband phase noise ratio normalized to a 1 Hz bandwidth at various offsets from the carrier frequency (Figure 18). These two techniques and the correlation between them are discussed in a number of application notes and technical papers (Ref. 2, 11) Appendix A6, 7, 9, 10, and 14.

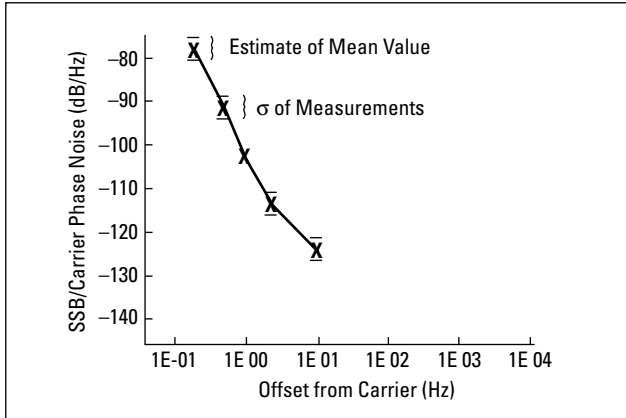

Figure 18. Phase spectral density at specific offsets from the carrier.

Drive Energy

A quartz crystal is analogous to a mechanical block. The clock relies upon the main spring energy to keep the pendulum going. The crystal requires energy to sustain the mechanical vibration which in turn maintains the piezoelectric action. The resonate frequency of the oscillator will change with a variation in the drive energy. The frequency of an AT cut crystal will change by 1×10^{-9} with a variation in drive of one microwatt. The drive level requirements will, of course, vary depending upon the crystal impedance. Excessive drive level may cause the mechanical vibrations to exceed the quartz elastic limits resulting in a fracture. The usual operating point is for minimum amplitude drive level since this is where maximum oscillator stability is achieved.

Gravity

The earth's gravitational force causes a stress related frequency effect which varies with the physical orientation of the crystal oscillator, i.e., a calibrated oscillator in one orientation will change frequency when rotated to another orientation. Typical offsets for 180° of rotation may be in the order of 2×10^{-9} (Figure 19) which is 1×10^{-9} per G. This effect is also experienced when crystals are subjected to acceleration.

Shock

Striking a crystal oscillator places a sudden stress on the crystal by temporarily deforming the mounting structure. Shock can result in a change of frequency by 1×10^{-9} per G. While not normally subjected to such extremes, a crystal oscillator should be able to withstand a 30G 1/2 sine wave shock for 11 milliseconds without permanent damage (Figure 19).

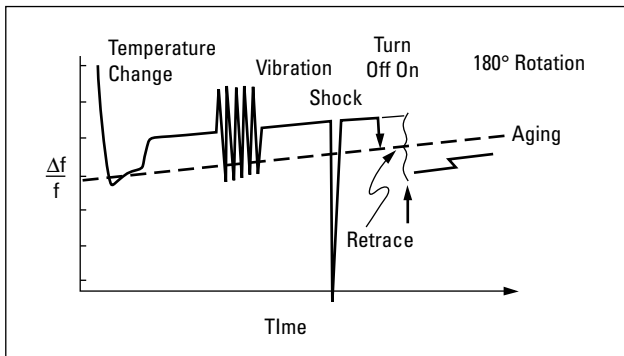

Figure 19. Graphic representation of environmental conditions.

Vibration

Shaking the crystal oscillator also causes stress in the crystal. These variations are typically of a longer duration but less severe than shock. Long-term, the effects of vibration tend to the average frequency, however, for short-term applications, the frequency can be expected to change by 1×10^{-9} per G (Figure 19).

Electromagnetic

Electromagnetic interference comes from sources located physically close to the oscillator. These effects are a result of signals being coupled into the electronics of the circuit rather than on the crystal. Careful design, like the use of torroids in the oscillator and placing the oscillator away from fans and transformers, etc., will reduce the effects to insignificant values. Care should also be exercised in placement of measurement instruments using oscillators since large signals, i.e., from a radio transmitter, could couple into the oscillator.

Retrace

Turning on an oscillator begins the generation of a usable frequency, which as explained earlier, changes with time (aging). When an oscillator is turned off and then back on, it will not necessarily start at the same frequency at which it had been operating. Eventually the oscillator will begin to age at its previous rate but will most likely be offset slightly from its original frequency. A typical retrace offset may be in the order of 1×10^{-8} (Figure 19). Another offset error which is similar to retrace is that of temperature hysteresis, i.e., an oscillator whose temperature is raised by several tens of degrees and then lowered may not return to the same start frequency.

Typical Performance of Oscillator Compensation Techniques

There are three crystal oscillator configurations which are in common use for instrument frequency sources. These configurations attempt to compensate for variations due to crystal characteristics primarily that of the temperature coefficient. The three types are (1) room temperature crystal oscillator (RTXO), (2) temperature compensated crystal oscillator (TCXO), and (3) oven controlled temperature crystal oscillator.

The RTXO typically uses a hermetically sealed crystal and individual components to build the oscillator circuit. The TCXO encases the crystal, the temperature compensating components, and the oscillator circuit in a container. The oven controlled approach adds a heater and the heater control to the oscillator circuit and puts the temperature influenced elements in a thermally insulated container.

Selecting the right oscillator for the job requires a comparison of the specifications between the various oscillator types and determining how this affects the measured results. The user can do little in the way of changing the crystal structure, oscillator design, and oven circuitry but by comparing specific performance an intelligent choice can be made. The major specifications to be considered for each type oscillator are temperature, time (aging and short-term stability), line voltage, and warm up.

Before embarking on a comparison program, it is wise to define the units to be used. Since the main objective is an accurate frequency, variations from this can be defined as a fractional frequency error, $\Delta f/f$, where Δf is the frequency error and f is the nominal frequency. Fractional error is a dimensionless number and can, therefore, be used to describe variations due to time, temperature, voltage, etc. The total variation is the sum of the individual variations.

Fractional frequency error will generally be given as \leq or \pm to signify a band of errors, i.e., $\pm 1 \times 10^{-7}$. Figure 20 shows various other ways in which errors can be specified and a conversion chart for quick reference.

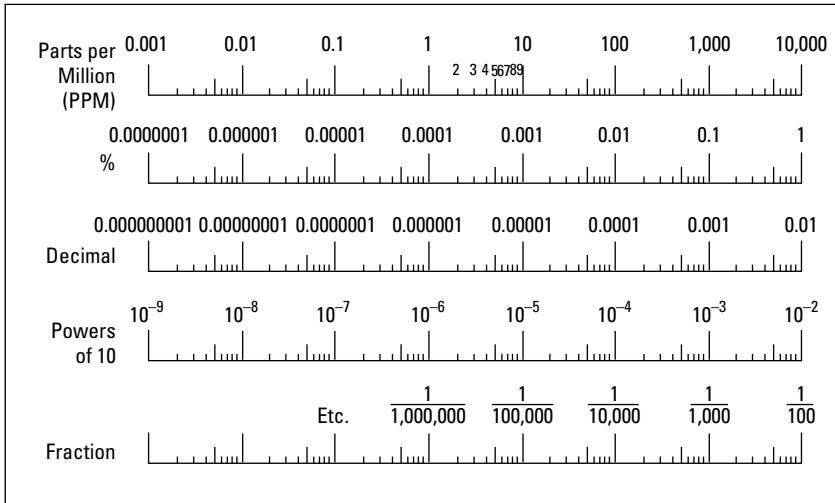

Figure 20. These factors are specified in various ways: parts per million (PPM), percent, as a deviation from a nominal frequency expressed as some power of 10, or as a fraction.

Temperature

RTXO: Room temperature crystal oscillators use crystals which have been manufactured for minimum frequency change over a change in temperature. This is accomplished primarily through the choice of the crystal cut and finishing process.

The frequency variation for an AT cut may be less than 2.5 ppm, 2.5×10^{-6} , over a 0 to 50 degree range (Figure 21). Since the user is not informed as to how the crystal actually acts on a per degree basis, it must be assumed that the entire variation could occur over a small portion of the temperature range. Thus, the 2.5×10^{-6} specification could be reached by the changes in ambient temperature inside an instrument.

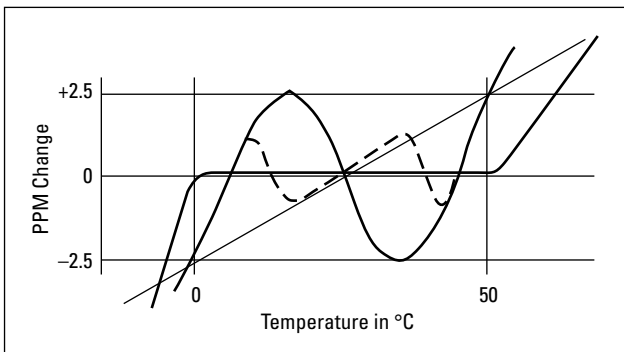

Figure 21. Frequency temperature plots for several room temperature oscillators.

TCXO: The temperature compensated oscillator uses components external to the crystal to offset the temperature effects. This could be in the form of a relatively simple circuit, such as capacitors, thermistors, etc., having opposite temperature coefficients, or a series of compensating elements and an amplifier used to control a voltage tuned capacitor which is part of the oscillator circuit. The individual compensating elements may only provide for limited correction over portions of the temperature range. This can result in several small frequency excursions over the entire operating range as evidenced in an actual temperature vs frequency plot (Figure 22). The TCXO typically has a temperature characteristic which is 5 times better than an RTXO or less than 5×10^{-7} for a 0–50° change.

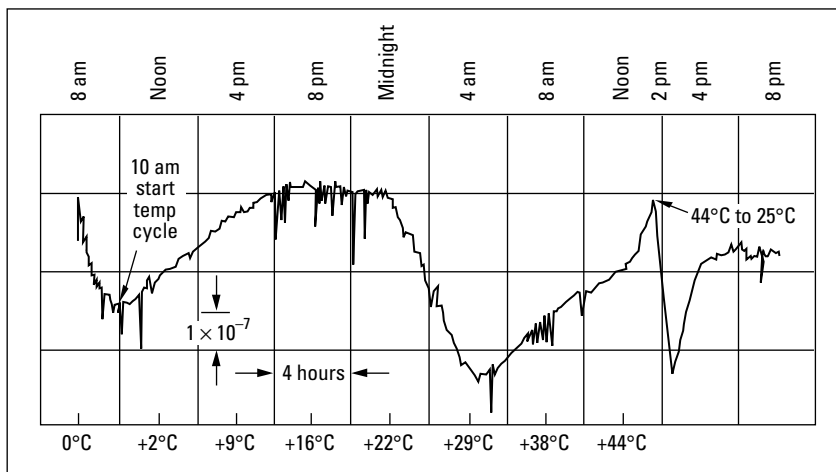

Figure 22. Actual plot of a TCXO over 0–44° change and the excursion encountered for a rapid change from 44° to 25°.

Since the TCXO may have nonlinear performance, the unit may require an offset in frequency at some temperature in order to maintain the specification over the entire range. Figure 23 illustrates how the frequency must be offset by –5 Hz at 25 degrees Celsius to meet the manufacturer’s specification for a particular TCXO. The offset number for each TCXO is typically printed on the side of the case. The user who always operates at a specific temperature should adjust the oscillator frequency to remove this bias effect since it could result in different values from two similar products.

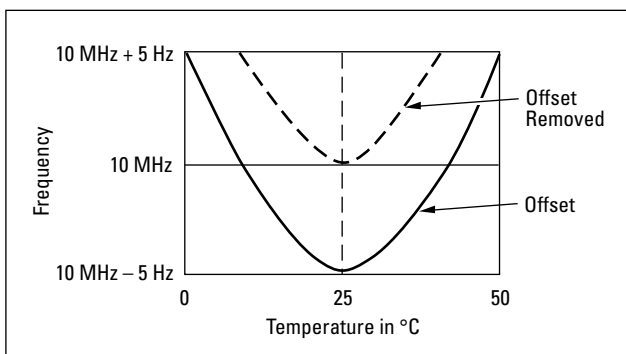

Figure 23. The adjustment of this TCXO for compliance with temperature over its full range results in a frequency offset at 25°.

Oven Controlled Crystal Oscillators: The third technique of temperature compensation is to place the crystal and temperature sensitive elements within a temperature controlled environment. A heating element is used to maintain the temperature of operation at the crystal turn-over point. This is the point of minimum change as indicated on the frequency vs temperature curve and is determined by the crystal cut (Figure 24). The best oscillator stability is achieved when the operating point is 15 to 20 degrees above the highest temperature to which the unit will be exposed.

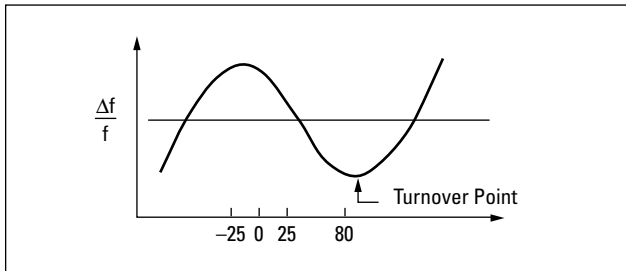

Figure 24. Selection of oven turn over point based upon the crystal characteristic curve.

Two oven controller techniques are in common use for the purpose of maintaining a constant temperature on the crystal assembly. They are the switching controller and the proportional controller. The switching controller turns the power off when the maximum temperature is reached and on at the minimum level much like a home thermostat. The proportional oven oven controller varies the current to the heater or the duty cycle of the heater voltage inversely based upon the offset of the oven temperature from the desired level. The switching oven may actually have a worse temperature specification than the TCXO due to heating and cooling the crystal. Once the proportional oven has stabilized to its operating temperature, the frequency of the oscillator will remain very stable, typically $<7 \times 10^9$ over a 0 to 50 degree Celsius temperature variation.

Time

Long-Term

The frequency of an oscillator changes due to aging. Aging is the second largest source of measurement error, the first being temperature. Calibration removes the aging offset and returns the oscillator to its nominal operating frequency. Therefore to ensure an accurate frequency the oscillator must periodically be calibrated. The rate at which the crystal ages and the time since calibration must be considered in determining the accuracy of the measurement. Specifications for aging may be given in terms of days or months, when given in days a monthly rate is found by multiplying the daily rate times 30 days. The monthly rate, however, cannot be divided by 30 to obtain a daily rate since this number would be masked by the effects of temperature

and other environmental conditions. Aging for a RTXO will typically be less than 3×10^{-7} for a 30-day period.

Extra care in manufacturing the crystal resonator can reduce the effects of aging. Since the effects of temperature are reduced by the addition of selected compensating elements in the TCXO, it is advantageous to reduce the aging component. Aging of a TCXO can be slightly less than that of a room temperature crystal. A typical specification for aging is less than 1×10^{-7} per month.

Aging for oven controlled oscillators is usually specified in terms of days and must be measured after warm-up has been completed. A high stability proportional oven will have a typical aging rate of less than 5×10^{-10} per day. Translating this in terms of months ($5 \times 10^{-10} \times 30$ days) = 1.5×10^{-8} , nearly an order of magnitude better than the TCXO.

Short-Term

Short-term variations in the oscillator output may be further degraded by where the oscillator circuit is located. It is, therefore, important that the design engineer in placing the oscillator within an instrument, be aware of the sources of interference which cause short-term variations. For some oscillator applications time domain stability is of little importance since other characteristics mask the effects. Other applications require extremely stable oscillators for short periods of time so time domain stability becomes extremely important.

RTXO, short-term, time domain stability is typically 2×10^{-9} for a 1-second average. TCXO units are typically twice as good as the room temperature unit or 1×10^{-9} for a 1-second average. Oven units may be 2 orders of magnitude better than the TCXO with high performance units being 1×10^{-11} for a 1-second average.

Line Voltage

The line voltage specification includes effects from a number of sources. Some of these are power consumption in the power supply resulting in temperature changes, voltage changes in the oscillator circuit, amplitude changes in the oscillator drive level which can cause instability, and even phase changes in the feedback which pulls the frequency slightly. Variations between the oscillator types is primarily due to a better quality of regulation, the use of electronic frequency control circuits and the selection of better components. Line voltage specifications for an instrument refer to changes in the AC line supply power. RTXO variations will typically be less than 1×10^{-7} for a 10% line voltage change. TCXO variations are 5×10^{-11} for a 10% line voltage change, a 2 times improvement over the room temperature unit. Oven units are 1×10^{-10} for a 10% line voltage change which is 1,000 times better than the RTXO and 500 times better than the TCXO.

Warm Up

Warm up is a special case of temperature variation which is brought about by the temperature rise from oscillator turn-on until stable operating point is reached. It may not be apparent that an RTXO and TCXO would have a warm up specification, and in fact, it is typically not specified. However, any instrument when placed into operation will generate a certain amount of heat. This heat elevates the temperature surrounding the crystal, and therefore, causes a frequency change.

Examples of warm up are provided in Figures 25A-E for the various oscillator types. Note that the actual time required to reach a stable frequency is significantly longer for the RTXO and TCXO during which the frequency may continue to change by parts in 10^7 and more.

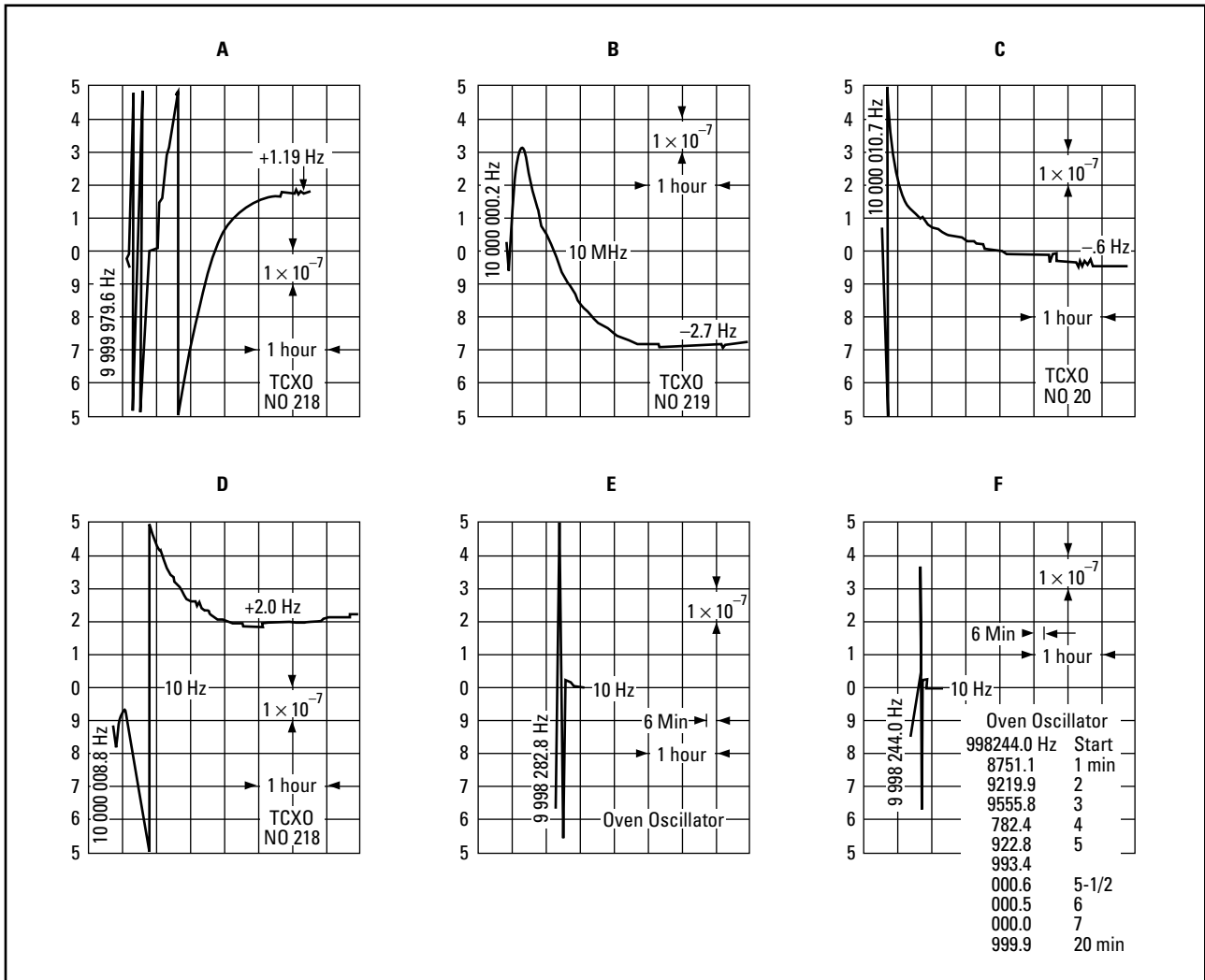

Figure 25. A is a RTXO warm up curve. B, C and D are typical TCXO warm up characteristics. The long time (3 hours) is due to changes in temperature inside the instrument. E and F are oven oscillators. Stability is achieved in ≈ 20 minutes.

Warm up specifications for oven controlled oscillators are given in terms of the final frequency value after warm up is completed. A typical time for warm up might be 20 minutes at which time the frequency will be within 5 parts in 10⁹ of its final value. Any calibration adjustments on the oscillator frequency should be performed after the crystal has reached its stable range.

Figure 26 shows the effects of warm up and the offset contributed by retrace. From this it should be apparent that to maintain the accuracy and stability of an oscillator, the unit should be kept at its operating temperature. Many instrument manufacturers now provide the capability of keeping power to the oven oscillator.

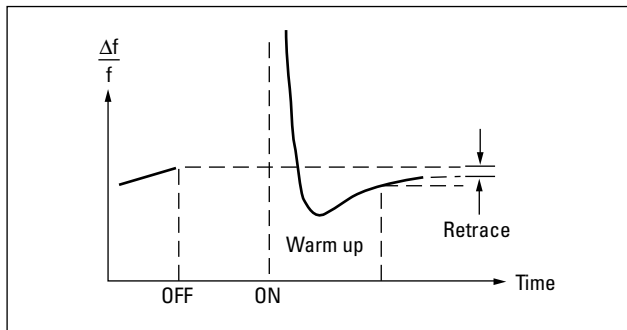

Figure 26. Graphic presentation of warm up and retrace.

A comparison chart of the various crystal oscillators and their typical specifications for aging, temperature, line voltage, etc., is provided in Figure 27.

	Room Temperature	TCXO	High Stability Oven
Aging Rate	$<3 \times 10^{-7}/\text{mo.}$	$<1 \times 10^{-7}/\text{mo.}$	$<1.5 \times 10^{-8}/\text{mo.}$ usually specified $<5 \times 10^{-10}/\text{day}$
Short-Term (1 s average)	$<2 \times 10^{-9}$ rms	$<1 \times 10^{-9}$ rms	$<1 \times 10^{-11}$ rms
Temperature 0°C — 50°C	$<2.5 \times 10^{-6}$	$<5 \times 10^{-7}$	$<7 \times 10^{-9}$
Line Voltage 10% Change	$<1 \times 10^{-7}$	$<5 \times 10^{-8}$	$<1 \times 10^{-10}$
Warm up	—	—	20 Minutes (5×10^{-9})

Figure 27. Comparison Chart

Oscillator Influence on Measurement Accuracy

The quartz oscillator is a relatively inexpensive method of obtaining an accurate time standard which when periodically calibrated, will exhibit traceability to the basic unit of time, the second, as defined by the XIII General Conference of Weights and Measures, in October 1967. When incorporated in a measurement instrument, any errors which are a result of the crystal oscillator must be given consideration before the accuracy of the instrument can be determined. This section will explore the application of the quartz oscillator when used in a frequency counter and a frequency synthesizer. The basic operation of the instrument will not be explained in detail since this may be found in other readily available sources. Appendix A.

Frequency Counters

The Universal Frequency Counter can make a number of measurements such as frequency, period, period average, ratio, time interval, and time interval-average. These measurements are really extensions of a ratio measurement using the fundamentals of frequency and time. When measuring frequency, the crystal oscillator is used to determine a precise measurement interval during which the input frequency is totalized.

The error associated with a frequency measurement consists mainly of two parts: the ± 1 count and the \pm time base error. The second error of the specification \pm time base error, is the part contributed by the crystal oscillator and its associated circuitry. This error is a direct result of changes in frequency of the oscillator and is made up of temperature effects, aging, short-term stability, voltage changes, and warm up.

To compute the time base error for a particular measurement, the individual fractional frequency errors must be determined. These errors will typically be specified on the data sheet for the instrument as follows:

Aging per month	3×10^{-7}
Temperature 0 to 50°	2.5×10^{-6}
Line Voltage $\pm 10\%$ Change	1×10^{-7}

The total error for aging is the rate per month times the number of months since calibration: $3 \times 10^{-7} \times 3 \text{ months} = 9 \times 10^{-7}$. Temperature and line voltage must be considered over the entire variation range so that the total error is:

Temperature	2.5×10^{-6}
Aging	9×10^{-7}
Line Voltage	1×10^{-1}
$\Delta f/f$ Total	3.5×10^{-6}

The error in the measurement equals the nominal frequency f multiplied times the fractional frequency error $\Delta f/f$.

$$\begin{aligned} \text{i.e.: } f &= 10 \text{ MHz; } \Delta f/f = 3.5 \times 10^{-6} \\ 10 \times 10^6 \times 3.5 \times 10^{-6} &= \pm 35 \text{ Hz} \end{aligned}$$

The actual frequency for this measurement is 10 MHz \pm 35 Hz or falls somewhere between 9.999965 MHz and 10.000035 MHz. These calculations were made using worst case error. It is possible that some errors will be positive and some negative producing offsetting effects.

This accuracy may or may not be adequate depending upon the application. If not, a look at the computations reveals that a major contributor to the $\Delta f/f$ total, is from temperature. Since this calculation used an RTXO, selection of a TCXO or an oven oscillator will reduce this factor. Once this factor has been reduced below 1×10^{-7} , the other elements of the accuracy statement must be examined if an improvement is required.

Frequency Synthesis

The frequency synthesizer translates the stable frequency of a precision frequency standard to one of thousands or even billions of frequencies over a spectrum range of DC to 18 GHz. Two methods have been used in frequency synthesis - the direct and indirect method. Direct synthesis is accomplished by multiplying, dividing, and mixing while the indirect method derives its frequency from one or more phase locked voltage tuned oscillators. The stability and accuracy in either case is derived from the reference source. The fractional frequency errors contributed by aging, temperature, and line voltage as they affect the oscillator must be summed to determine the frequency error.

Calculations for the synthesizer accuracy can be taken directly from the data sheet. For $\Delta f/f$:

Temperature 0 — 50 degrees	= 5×10^{-9}
Line Voltage \pm 10% change	= 5×10^{-10}
Aging $5 \times 10^{-10} \times 20$ days	= 1×10^{-8}
$\Delta f/f$ Total	= 1.55×10^{-8}

Selecting a frequency of 1 MHz, the error is $1 \times 10^6 \times 1.55 \times 10^{-8}$ or $1.55 \times 10^{-2} = \pm 0.0155$ Hz, at 10 GHz the error is $10 \times 10^9 \times 1.55 \times 10^{-8} = 1.55 \times 10^2$ or 155 Hz. The error percentage is the same for both frequency settings. Whether or not this amount of error is tolerable depends upon the application for which the frequency is being used.

Improvements in the frequency accuracy can be obtained through calibration of the oscillator or by using an external reference such as a cesium standard.

Appendix A

1. "Understanding Microwave Frequency Measurements", AN 144, Hewlett-Packard Co.
2. "Measuring the Stability of a Frequency Source", AN 174-6, Hewlett-Packard Co.
3. "Measuring Fractional Frequency Standard Deviation (Sigma) Versus Averaging Time (Tau)", AN 174-7, Hewlett-Packard Co.
4. "Timekeeping and Frequency Calibration", AN 52-2, Hewlett-Packard Co.
5. "Fundamentals of Time and Frequency Standards", AN 52-1, Hewlett-Packard Co.
6. "Characterization of Frequency Stability", IEEE Transactions on Instrumentation and Measurement, pp 105-120, May 1971.
7. "The Measurement of Frequency and Frequency Stability of Precision Oscillators", NBS Technical Note 669, May 1975.
8. "Wave Analyzer Dynamic Range and Bandwidth Requirements for Signal Noise Analysis", Technical Report RE 76-26, U.S. Army Missile Command. Redstone Arsenal, Alabama 35809.
9. "Frequency Domain Stability Measurements: A Tutorial Introduction", NBS Technical Note 679, U.S. Department of Commerce/National Bureau of Standards.
10. "Frequency Stability Specification and Measurement: High Frequency and Microwave Signals", NBS Technical Note 632, U.S. Department of Commerce/National Bureau of Standards.
11. "Spectrum Analysis ... Noise Measurements", Spectrum Analyzer Series Application Note 150-4, Hewlett-Packard Co., April 1974.
12. "Short-Term Stability for a Doppler Radar: Requirements Measurements and Techniques", Proceedings of the IEEE Vol. 54, No. 2, February 1966. D.B. Leeson, Senior Member, IEEE, and G.F. Johnson, Senior Member, IEEE.
13. Luis Peregrino/David W. Ricci, "5390A Technical Paper", presented at the Thirtieth Annual Frequency Control Symposium, June 2-4, 1976.
14. Michael C. Fischer, "Frequency Stability Measurements Procedures", Technical Paper presented at the Eighth Annual Precise Time and Time Interval Applications and Planning Meeting, December 1976.

References

1. "Basic Electronic Instrument Handbook", Clyde Coombs, Editor, McGraw Hill, 1972, Chapter 9, Chapter 33, Chapter 35.
2. "Understanding and Measuring Phase Noise in the Frequency Domain", AN 207, Hewlett-Packard Co.
3. W.G. Cady, "Piezoelectricity, An introduction to the Theory and Applications of Electromechanical Phenomena in Crystals", (New revised edition in two volumes), Dover Publications, Inc., New York, 1964.
4. Paul Bryan, "Precision Quartz Crystals and How They Relate to the Electronics Manufacturing Industry", paper 29 presented at Wescon Electronic Show and Convention, San Francisco, September 19-21, 1977.
5. Walter L. Bond, John A. Kusters, "Making Doubly Rotated Quartz Plates" presented at the 31st Frequency Control Symposium, Atlantic City, June 1977.
6. John A. Kusters, Jerry G. Leach, "TTC's - Further Developmental Results", presented at the 31st Frequency Control Symposium, Atlantic City, June 1977.
7. "Frequency Standards and Clocks: A Tutorial Introduction", NBS Technical Note.
8. Bottom, Virgil E., "The Theory and Design of Quartz Crystal Units", McMurray Press, Abilene, Texas, April 1968.
9. Dwyer, D.F.J., "Characteristics of Quartz Crystal Oscillators", Electronic Engineering, pp 24-25, April 1977.
10. Ottowitz, Peter J., "A Guide to Crystal Selection", Electronic Design, pp 48-51, May 10, 1966.
11. "Characterization of Frequency Stability", NBS Technical Note 394, U.S. Department of Commerce/National Bureau of Standards.
12. "Quartz Crystal Oscillators", Bench Briefs, Volume 13, No. 3, July-August 1973, Hewlett-Packard Co.
13. "Calibration of an Oscillator", Bench Briefs, Volume 13, No. 4, September-October 1973, Hewlett-Packard Co.
14. "Fundamentals of Electronic Counters", AN 200, Hewlett-Packard Co.

For more information about Hewlett-Packard Test and Measurement products, applications, services, and for a current sales office listing, visit our web site, <http://www.hp.com/go/tmdir>. You can also contact one of the following centers and ask for a test and measurement sales representative.

United States:
Hewlett-Packard Company
Test and Measurement Call Center
P.O. Box 4026
Englewood, CO 80155-4026
1 800 452 4844

Canada:
Hewlett-Packard Canada Ltd.
5150 Spectrum Way
Mississauga, Ontario
L4W 5G1
(905) 206 4725

Europe:
Hewlett-Packard
European Marketing Centre
P.O. Box 999
1180 AZ Amstelveen
The Netherlands
(31 20) 547 9900

Japan:
Hewlett-Packard Japan Ltd.
Measurement Assistance Center
9-1, Takakura-Cho, Hachioji-Shi,
Tokyo 192, Japan
(81) 426 56 7832
(81) 426 56 7840 Fax

Latin America:
Hewlett-Packard
Latin American Region Headquarters
5200 Blue Lagoon Drive
9th Floor
Miami, Florida 33126
U.S.A.
(305) 267 4245/4220

Australia/New Zealand:
Hewlett-Packard Australia Ltd.
31-41 Joseph Street
Blackburn, Victoria 3130
Australia
1 800 629 485

Asia Pacific:
Hewlett-Packard Asia Pacific Ltd.
17-21/F Shell Tower, Time Square,
1 Matherson Street, Causeway Bay,
Hong Kong
(852) 2599 7777
(852) 2506 9285