

Application Note 196



AUTOMATED MEASUREMENTS

Using the 436A Power Meter



HEWLETT  PACKARD

Application Note 196

AUTOMATED MEASUREMENTS

Using the 436A Power Meter

October 1975

CONTENTS

INTRODUCTION	1
SECTION 1	2
Determining Power Measurement Accuracy	
SECTION 2	4
Advantages of Automating Measurements	
SECTION 3	5
Data Logging Using the HP 5150A Thermal Printer	
SECTION 4	6
50 dB Dynamic Range Logarithmic Recorder Output	
SECTION 5	7
Signal Generator Calibration	
SECTION 6	10
Gain & Attenuation Measurement	
SECTION 7	13
Power Sensor Calibration	
SECTION 8	16
Other Automated Power Measurements	
APPENDIX A	17
Measuring AM Modulation Index with a Power Meter	
APPENDIX B	17
Multiple Mismatch	
ADDITIONAL REFERENCES	18

INTRODUCTION

This application note describes several systems which can be built around the Hewlett-Packard Interface Bus (HP-IB) compatible 436A Power Meter. Five systems deemed to be of general interest are described in detail, and ideas for many specialized applications, with references, are also included.

The Hewlett-Packard Interface Bus (HP-IB) is an instrumentation interface standard which defines the electrical, mechanical, and functional aspects of an instrumentation interface. By standardizing these characteristics, the HP-IB allows automatic test systems to be assembled with a minimum amount of effort and at a reasonable cost.

Section 1 is a short review of the sources of error in power measurements, with specific emphasis on the

advantages of using low SWR sensors, such as those available for use with the 436A Power Meter.

Section 2 describes both the general benefits of automating measurements and the features of the 436A that make it well suited for automatic power measurements.

Sections 3 - 7 are the heart of this application note. Five automatic test systems built around the 436A Power Meter are described in detail. Each section includes a brief description, equipment list, measurement procedure, measurement evaluation, ideas for additions to the basic measurement, and, where appropriate, a 9830A Calculator program listing.

Section 8 completes this application note by providing a list of several possible automated power measurements which are beyond the scope of this note.

SECTION 1

Determining Power Measurement Accuracy

Power measurement accuracy is largely a function of the reflection coefficients of the various components in a measurement set-up: The larger these reflection coefficients, the less accurate the measurement.

As the following paragraphs will show, the low SWR (small reflection coefficient) of the HP 8480 Series of power sensors can dramatically improve power measurement accuracy. In addition, the calibration factor data supplied with each sensor allows measurement accuracy to be stated in terms of standards defined by the National Bureau of Standards (NBS).

Power transfer equations

For the simple power measuring system shown in Figure 1, the relationship between the maximum power available from the source, P_{max} , and the power actually indicated by the "perfect" power meter, P_I , is:

$$P_I = \left[\frac{(\eta_e) (1 - |\Gamma_L|^2) (1 - |\Gamma_G|^2)}{|1 - \Gamma_L \Gamma_G|^2} \right] \cdot P_{max} \quad 1-1$$

where

η_e = power sensor effective efficiency

Γ_G = generator complex reflection coefficient at plane A

Γ_L = power sensor complex reflection coefficient at plane A.

Similarly, the relationship between the power a generator will deliver to a perfectly matched load, P_{zo} , and the power indicated by the power meter is:

$$P_I = \left[\frac{(\eta_e) (1 - |\Gamma_L|^2)}{|1 - \Gamma_L \Gamma_G|^2} \right] \cdot P_{zo} \quad 1-2$$

The first equation shows that the power indicated by the power meter will not be an accurate representation of P_{max} unless $\eta_e = 1$ and unless either $\Gamma_L = \Gamma_G = 0$ or $\Gamma_L = \Gamma_G^*$. (Γ_G^* is the complex conjugate of Γ_G .) Similarly, P_I will not equal P_{zo} unless $\eta_e = 1$ and $\Gamma_L = 0$.

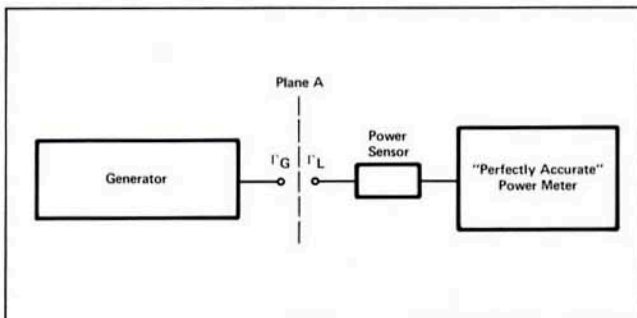

Figure 1. Simple power measurement.

In other than these ideal cases, these equations can be used to compute P_{max} and P_{zo} from the indicated power if the terms in the equations are known. To this end, Hewlett-Packard measures the term $[(\eta_e) (1 - |\Gamma_L|^2)]$ at 17 frequencies and supplies this information as a calibration factor curve which is affixed to each sensor. In

addition, HP also measures the magnitude and phase of Γ_L at 17 frequencies and supplies this data on a computer printout with its 8481A, 8481H and 8484A Power Sensors, as shown in Figure 2. Thus, if the user can define the magnitude and phase of the generator's reflection coefficient, Γ_G , at plane A in Figure 1, equations 1-1 and 1-2 can be used to compute P_{max} and P_{zo} exactly.

SERIAL NUMBER 481.				
MHZ	EE%	CF-%	RHO	ANG
2000	98.4	98.4	.020	-81.6
3000	98.1	98.1	.018	149.3
4000	98.0	97.9	.022	14.0
5000	97.8	97.8	.021	-95.8
6000	97.5	97.5	.010	125.2
7000	96.4	96.4	.019	-50.0
8000	95.8	95.7	.029	-169.7
9000	96.1	96.0	.040	67.9
10000	95.6	95.4	.051	-42.3
11000	95.2	95.1	.044	-141.7
12400	95.2	95.1	.035	43.8
13000	94.5	94.3	.045	-18.7
14000	94.4	94.1	.059	-93.0
15000	94.5	94.2	.053	-173.8
16000	93.8	93.7	.018	25.0
17000	94.5	94.0	.070	-115.6
17999	95.9	95.0	.095	150.2

Figure 2. Computer printout supplied with each 8481A, 8481H and 8484A Power Sensor. Printout shows effective efficiency (EE) calibration factor (CF), and magnitude (RHO) and phase (ANG) of reflection coefficient.

However, in general, only the magnitude of Γ_G is known, and therefore, the vector expression $|1 - \Gamma_L \Gamma_G|^2$ can only be evaluated at two extreme limits, $(1 + |\Gamma_L| |\Gamma_G|)^2$ and $(1 - |\Gamma_L| |\Gamma_G|)^2$. This means that without knowing the phase relationship between the incident and reflected waves, it is impossible to predict whether they will tend to cancel or tend to reinforce one another.

Mismatch uncertainty

This ambiguity caused by lack of phase information is called **mismatch uncertainty** and is generally the **largest single source of error in power measurements**. The only way to reduce its effects, other than to measure the magnitude and phase of both Γ_G and Γ_L , is to reduce generator and sensor mismatch by tuning, padding, or leveling.

In addition, mismatch can also be reduced by building a sensor with lower SWR. Therefore, Hewlett-Packard manufactures a series of thermocouple and diode power sensors which offer excellent match over a 100

kHz to 18 GHz frequency range. For instance, the HP 8481A Thermocouple Power Sensor's SWR is guaranteed to be less than 1.10 ($|\Gamma_L| < 0.048$) to 2 GHz, less than 1.18 ($|\Gamma_L| < 0.082$) to 12.4 GHz, and less than 1.28 ($|\Gamma_L| < 0.128$) to 18 GHz.

Example — Accuracy Improvement Using Low SWR Sensor

Using a sensor having a SWR of 1.5 ($\Gamma_L = 0.20$) at 2 GHz to measure a generator having a SWR which is also 1.5, the measurement error due to mismatch uncertainty alone could be as much as

$$[1 \pm (0.20) (0.20)]^2 = \frac{1.0816}{0.9216}$$

or in percentage, +8.16%
-7.84%

However, using an 8481A sensor with a SWR guaranteed to be less than 1.10 ($\Gamma_L < 0.048$) at 2 GHz, the uncertainty is reduced to

$$[1 \pm (0.048) (0.20)]^2 = \frac{1.0191}{0.9810}$$

or in percentage, +1.91%
-1.90%

Total measurement uncertainty

A statement of uncertainty allows the results of any measurement to be compared with primary standards. It is therefore important to know all the sources of error in any measurement. Table 1 lists all errors encountered in making the simple measurement shown in Figure 1 when using a 436A Power Meter.

Measurement uncertainties must be expressed as percentages if they are to be added to obtain total worst case measurement uncertainty for a single measurement. If several measurements are to be multiplied together to obtain a final result, the errors must also be multiplied, or equivalently, the errors must be expressed in dB and added. The following equations convert dB error into % error and vice versa.

$$\text{dB error} = 10 \text{ Log } \left(1 + \frac{\% \text{ error}}{100} \right)$$

$$\% \text{ error} = 100 \left(10^{\frac{\text{dB error}}{10}} - 1 \right)$$

Source of error	Typical value with 436A and 8480 sensor	Can be reduced to	Method of reducing errors
Mismatch	1 - 8%	<0.1%	Tuning at each frequency
Calibration factor uncertainty	1.5 - 5.5%	<2.7%	Special calibration by standards lab
Reference oscillator uncertainty	1.2%	<0.7%	Special calibration by standards lab
11708A calibrator pad (8484A only)	1.1%	<0.5%	Special calibration by standards lab
Instrumentation* uncertainty	0.5%	<0.5%	Use external DVM with more than 4 digits of resolution to measure recorder output voltage
±1 count	0.2%	<0.2%	"
Zero set	0.2%	<0.2%	"
Zero carryover	0.2%	0%	Zero on same range as measurement
Noise	0.2%	<0.1%	Average several readings
Mismatch uncertainty in measuring reference oscillator power	0.2%	<0.1%	Tuning

* Add +1.5, -1.0% on top range only, when using a thermocouple sensor, to account for sensor non-linearity.

Table 1. Sources of error in absolute power measurements when using the 436A Power Meter.

SECTION 2

Advantages of Automating Measurements

Why automate?

The primary reason for automating any measurement is speed. By substituting a calculator or computer for the human operator, measurement speed can often be increased several orders of magnitude. In addition, automated test systems offer many other benefits: final results can be automatically calculated from raw measurement data; calibration information can be measured and stored, and then used during the actual test to reduce systematic errors; hard copy output such as graphs, charts, and tables can easily be generated.

The 436A Power Meter

The Hewlett-Packard 436A Digital Power Meter provides many outstanding features which make it an excellent choice for programmable power meter applications. The most important of these is its ability to interface directly into HP Interface Bus (HP-IB) systems. The HP-IB concept permits systems of low to moderate complexity to be assembled at a reasonable cost, with very little effort. In addition, because the HP-IB is identical to IEEE Standard 488-1975, a wide variety of compatible, off-the-shelf instrumentation is available.

The 436A offers complete programmability of mode (watts, dBm, dB reference, or dB relative to a previously set reference value), range, and zero. Also, the 436A can be used with any 8480 Series power sensor. These sensors offer measurement capability from 100 pW (-70 dBm) to 3 W (+35 dBm), at frequencies up to 18 GHz.

SECTION 3

Data Logging Using the HP 5150A Thermal Printer

Description

The system shown in Figure 3 measures power at regular time intervals and produces a hard copy output of these measurements. The time between measurements is selected by the sliding switches on the front panel of the 5150A. Time-of-day information can also be printed.

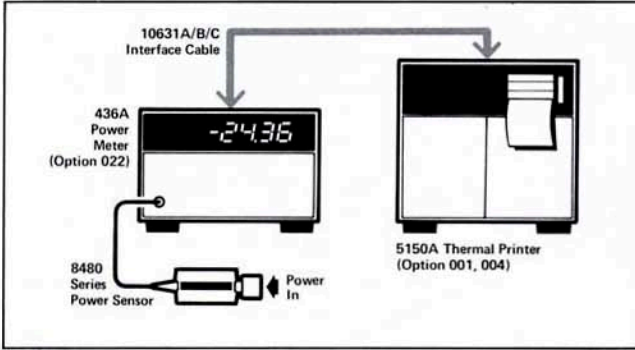

Figure 3. System for taking power readings at regular intervals using the 5150A Thermal Printer.

Equipment list

- 436A (Option 022) Power Meter
- 8480 Series Power Sensor
- 5150A (Option 001; Option 004) Thermal Printer
- 10631A/B/C Interface Cable.

Procedure

- 1) Connect the interface cable to the rear panel connectors on the power meter and on the printer.
- 2) Set the **normal-talk only** switch on the rear panel of the power meter to **talk only**.
- 3) On the rear panel of the printer, set the **L only** switch to 0. The **listening** LED below the address switches should light. Set the **BCD CMD** switch to 0. Set the **PRT CMD** switch to **LF**.
- 4) Zero and calibrate the power sensor to the power meter's reference oscillator according to the instructions in the 436A Operating and Service Manual.
- 5) Connect the power sensor to the power source to be monitored and use the front panel switches on the power meter to select watts, dBm, or dB (rel) mode.
- 6) Set the clock on the printer and select the desired print interval. Refer to the 5150A Operating and Service Manual for front panel operation details.

The printer will now trigger the power meter and take a reading at the end of each print interval. Figure 4 shows a typical printer output.

Addition's to the basic measurement

The 5150A Printer is also available with a scanner option (Option 003) which allows the user to sequentially address and accept data from up to 13 instruments on the HP Interface Bus. Using this option and several power meters, power from several sources can be continuously monitored.

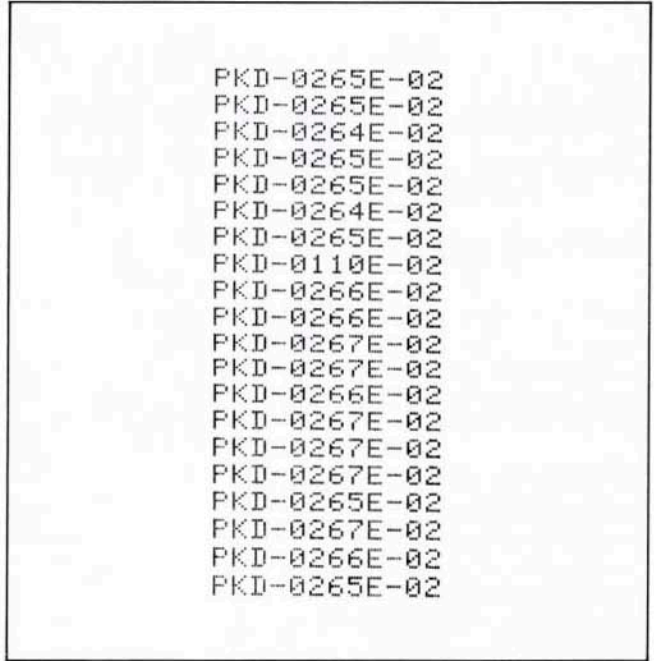

Figure 4. Printout from 5150A Thermal Printer showing power measurements. The three leading characters give information about the status, range, and mode of the 436A. See 436A Operating and Service Manual for an explanation of these characters.

SECTION 4

50 dB Dynamic Range Logarithmic Recorder Output

Description

The set-up shown in Figure 5 uses a D/A converter to generate a voltage proportional to the power reading in dB, thus simulating a logarithmic recorder output with a 50 dB dynamic range. This voltage can be used to drive an X-Y recorder or storage oscilloscope for sweep frequency testing.

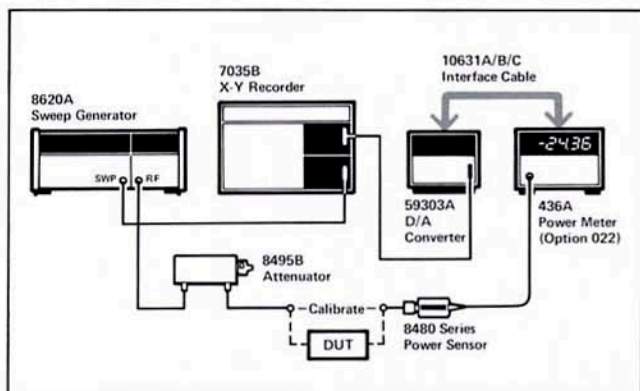

Figure 5. System for generating a voltage proportional to power reading, in dB, over a 50 dB dynamic range using the 59303A D/A converter.

Equipment list

- 436A (Option 022) Power Meter
- 8481A Power Sensor
- 59303A D/A Converter
- 8495B (Option 001) Step Attenuator
- 8620A Sweep Generator
- 7035B X-Y Recorder
- 10631A/B/C Interface Cable

Procedure

The following procedure describes how to make a swept measurement using the previously listed equipment.

- 1) Connect the equipment as shown in Figure 5.
- 2) Set the **normal—talk only** switch on the rear panel of the power meter to **talk only**.
- 3) Set the **addressable/listen only** switch on the rear panel of the A/D converter to **listen only**.
- 4) Set frequency limits for desired sweep on 8620A. Using either internal or external leveling, adjust **power level** vernier for maximum leveled power. Set **sweep mode** to **auto**, **trigger** to **ext.**, and **time** to **100**. Turn time vernier fully counterclockwise.
- 5) Set A/D converter front panel switches as follows:
digits converted: 000000
output mode: -9.99 V to +9.99 V
(Plus/Minus).
- 6) Connect 8481A Power Sensor directly to 8495B Attenuator. Set attenuator for 0 dB attenuation. Push **dB (ref)** button on power meter.
- 7) Turn **X range** and **Y range** switches on 7035A to 10 V/in. Turn X-Y recorder servo on. Use **Y-zero** control to set pen to desired zero position. Set 30 dB on attenuator. Adjust **Y range** switch and **range vernier** control to place pen to -30 dB position.

- 8) Temporarily set sweeper's **sweep mode** to manual. Set manual **sweep vernier** counterclockwise for minimum frequency and adjust **X zero** control on X-Y recorder to position pen to left side of paper. Turn **sweep vernier** clockwise for maximum frequency and adjust **X range** switch and **Range vernier** to position pen to desired end position on paper. Return sweep mode to auto.
- 9) Make single sweeps for 0, 10, and 20 dB settings on attenuator in order to obtain calibration lines.
- 10) Set attenuator to 0 dB and insert unknown device as shown in Figure 5. Make a sweep of the unknown device's characteristics.

Figure 6 shows the response of a low-pass filter obtained using the technique outlined above.

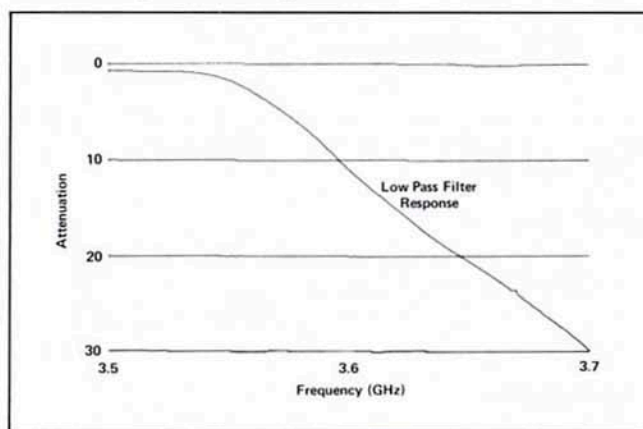

Figure 6. X-Y recorder plot of low-pass filter is made by using the system shown in Figure 5.

Measurement evaluation

Although this technique can produce a 50 dB dynamic range plot, the 436A Power Meter's 10-second settling time on the bottom 10 dB range requires a slower sweep than most sweep generators are capable of producing. Thus, this technique is limited in most cases to 30-40 dB dynamic range. Even on the power meter's upper ranges, a slow sweep speed is necessary to achieve high accuracy.

Also, the 59303A D/A converter can process only 3 digits of information, thus limiting resolution to 0.1 dB. However, this is generally quite adequate for plots made over a 30 to 40 dB range.

Finally, the small discontinuity in the plot at about 3.67 GHz is due to the power meter's autorange circuit which operates more slowly on the bottom two ranges.

Additions to the basic measurement

The **digits converted** switch on the D/A converter can be changed to 000000 to obtain 0.01 dB resolution over any 20 dB range. Follow the previous procedure except set the attenuator for 10 dB attenuation in step 6, and 20 dB attenuation in step 7.

A different power and frequency range can be measured using one of the other 8480 Series Power Sensors.

SECTION 5

Signal Generator Calibration

Description

The accuracy of a signal generator's frequency, power, and modulation settings directly affects measurement accuracy. It is, therefore, of the utmost importance to verify generator performance on a periodic basis. If this verification must be done often, or if a large number of units are involved, automation can greatly reduce costs.

The procedure presented in the following paragraphs shows how a signal generator's frequency, output power, output attenuator, and AM accuracies can be verified using only a power meter and frequency counter under calculator control. References to other application notes which describe the use of a programmable frequency counter to measure fractional frequency deviation and FM peak-to-peak deviation are given under the heading **Additions to the basic measurement**.

The calculator program listed at the end of this section illustrates how to implement the above procedure for testing the HP Model 8654B Signal Generator. This program can be easily modified to calibrate any other signal generator.

Equipment

- 436A (Option 022) Power Meter
- 8480 Series Power Sensor
- 5340A (Option 003) Frequency Counter
- 9830A Calculator
- 9866A Thermal Printer
- 8761B (Option 001) Coaxial Switch
- 59306A Relay Actuator
- 24 V Power Supply
- 11631A/B/C Interface Cables

Procedure

Connect the equipment as shown in Figure 7. The inset to this figure shows the connection details of the 8761B switch. The procedure for each individual test is as follows:

Output level accuracy

A signal generator is usually specified to have an output power which deviates from the reading on the dial by no more than $\pm X$ dB. To check this, take measurements as rapidly as the power meter will allow as the signal generator is tuned across each band. Correct each reading using the sensor's calibration factor data. (Interpolation can be used to generate calibration factor at frequencies other than those at which it is measured.) Compare the corrected readings to the output level setting and print an error message if the difference is more than the specified value.

Frequency accuracy

The frequency produced by a signal generator is usually specified to be within $\pm X\%$ of the dial setting. To check this, measure the frequency output of the signal generator and compare it to the dial setting. If the difference between the two values is greater than the specified value, print out an error message.

Step attenuator accuracy

The step attenuator on a signal generator is sometimes specified to have a certain incremental attenuation accuracy. To check this, take a reference reading at some power level using the dB[ref] feature on the 436A Power Meter. Change the attenuator setting and

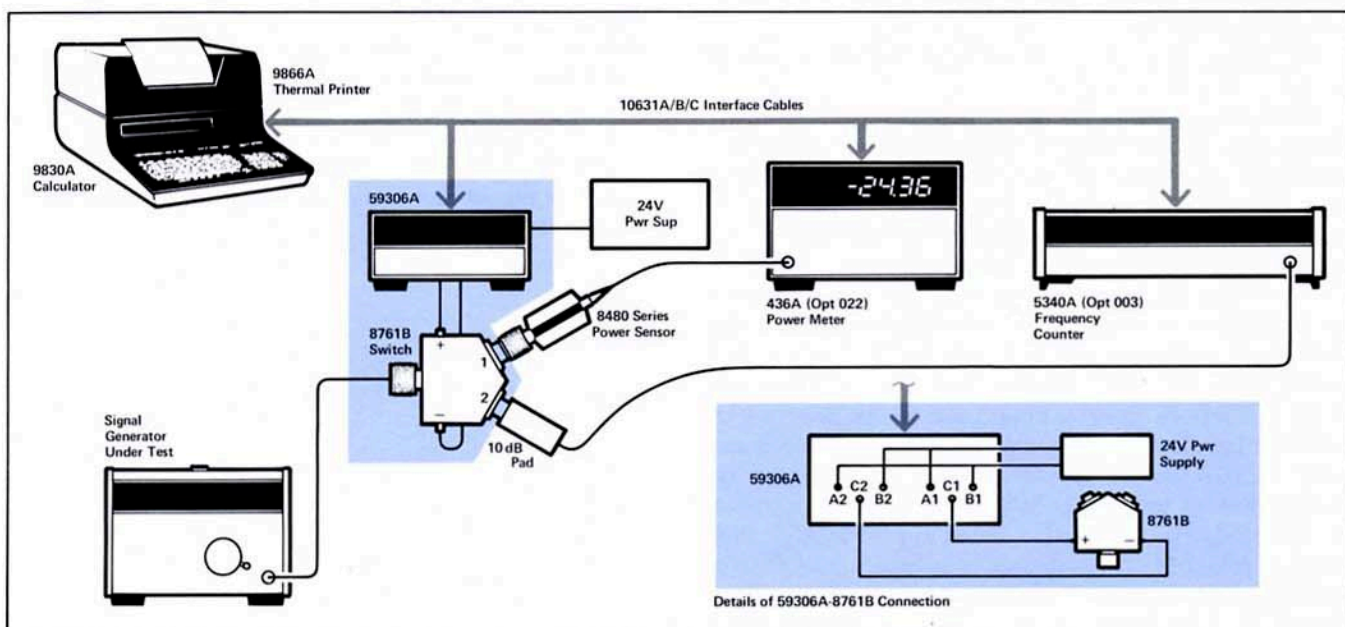

Figure 7. System for testing signal generator output level, frequency, step attenuator, and AM accuracies.

read the relative power change. If this power change differs from the attenuator change by more than a specified amount, print out an error message.

AM accuracy

AM modulation index can be measured using a power meter if the modulating waveform is a reasonably pure sine wave, and if the distortion introduced by the generator's modulator is reasonably low. The derivation in Appendix A shows that if these conditions are met, the modulation index is

$$m = \sqrt{2 \left(\frac{P_T}{P_c} - 1 \right)} \quad 5-1$$

where: P_T = total power of modulated waveform

P_c = power in unmodulated waveform (carrier).

Thus, to measure the accuracy of the AM meter, measure the signal generator power output both with and without modulation, and compute modulation index using equation 5-1. Print out an error message if the measured and set values differ by more than a specified amount.

Measurement evaluation

The accuracy of the output level measurement depends on all the factors shown in Table 1. However, because the 8761B Coaxial Switch is placed between the power sensor and the signal generator, it introduces both a loss and an additional mismatch uncertainty. The loss can be measured using the techniques described in Section 6, and can therefore be calibrated out, but the error resulting from mismatch cannot be eliminated. However, worst case limits for multiple mismatch error can be calculated using the multiple mismatch equation in Appendix B.

The accuracy of the frequency measurement is ± 1 count \pm time base error.

The accuracy of the step attenuator measurement is better than output level accuracy because the value measured is relative power, not absolute. Therefore, only mismatch uncertainty (caused by the change in reflection coefficient with a change in attenuation) and instrumentation uncertainty are significant.

The accuracy in measuring modulation index depends on the absence of large unwanted sidebands in both the modulated and unmodulated signal. For most lab quality signal generators, this constraint is easily met. However, some generators have a broadband noise floor which tends to increase the power of both the modulated and unmodulated signals. This in turn has the effect of making the power ratio in equation 5-1 closer to 1, therefore, making the modulation index appear smaller than what it really is. The solution is to use a low-pass or band-pass filter on the output of the signal generator if this is a problem. No such filter is needed when measuring AM accuracy of the 8654B.

Also, because only a small increase in power occurs for small modulation indices, this technique is limited to measuring indices of 0.2 or greater. Even for these large modulation indices, accuracy of the modulation index can be no better than the accuracy of the power ratio $\frac{P_T}{P_c}$.

Additions to the basic measurement

FM characteristics of signal sources can be measured with a calculator controlled frequency counter using the procedures outlined in Application Notes 174-7, **Measuring Fractional Frequency Deviation (Short Term Stability of Oscillators)**, and AN 174-8, **Measuring FM Peak-to-Peak Deviation**. These techniques are written around the 5345A (Option 011) Frequency Counter.

A somewhat simpler set-up can be put together by replacing the 8716B switch with a 3-resistor power splitter. As with the switch, the loss and mismatch of the power splitter must be taken into account. The drawback to this technique is that the signal cannot automatically be shut off for remotely zeroing the power meter.

9830A Calculator program

The following is a 9830A Calculator program which shows how the above procedures can be used to test the 8654B Signal Generator. The operator instructions and the pass/fail type of output is typical of programs written for production line testing.

Modification of this program for use with other signal generators could easily be done by changing the data statements in lines 1210-1300.

For simplicity, only one calibration factor is used in the flatness test. However, if calibration factor is available at several points in the signal generator's frequency band, this information could be added to the program, and calibration factor interpolated between frequencies.

Each segment of this program can be loaded into a special function key on the 9830A Calculator to make it easier to repeat one section of the program in the event of operator error.

Signal Generator Calibration Program for 9830A Calculator

```

10 REM-----SIGNAL GENERATOR CALIBRATION-----
20 REM
30 REM POWER METER LISTEN "-" TALK "M"
40 REM COUNTER LISTEN "2" TALK "R"
50 REM SWITCH ACTUATOR LISTEN "1"
60 REM
70 REM ZERO POWER METER AND INITIALIZE COUNTER
80 GOSUB 1310
90 REM
100 REM          CHECK FREQUENCY FLATNESS
110 REM
120 DISP "TURN MODULATION OFF"
130 STOP
140 DISP "SET OUTPUT LEVEL TO 0 DBM"
150 REM SET ERROR FLAG.
160 E=0
170 STOP
180 READ K
190 READ F1,F2
200 IF F1=0 THEN 570
210 FIXED 2
220 DISP "SET F1:"TO"ABS F2:"MHZ BAND"
230 STOP
240 REM SET SWITCH TO MEASURE POWER.
250 CMD "?U","A12"
260 REM SET POWER METER.
270 CMD "?U","9+DT"
280 REM TAKE 15 MEASUREMENTS.
290 REM THEN CHECK FOR END OF BAND.
300 FOR I=1 TO 15
310 CMD "?U","1","?MS"
320 FORMAT 3#,E12.0
330 ENTER (13,320)F
340 REM CHECK AGAINST +- 1.5 DB SPEC.
350 IF ABS(P/K)<1.5 THEN 460
360 REM IF FLATNESS IS OUT OF SPEC.
370 REM READ FREQUENCY AND PRINT OUT ERROR.
380 REM SET SWITCH TO READ FREQUENCY.
390 CMD "?U","B12"
400 REM READ FREQUENCY.
410 GOSUB 1530
420 E=1
430 PRINT "FLATNESS OUT OF SPEC AT:"
440 PRINT F1"MHZ " ;"ERROR="P/K;"DBM"
450 GOTO 190
460 NEXT I
470 REM SET SWITCH TO READ FREQUENCY;
480 CMD "?U","B12"
490 REM READ FREQUENCY.
500 GOSUB 1530
510 REM CHECK FOR END OF BAND.
520 IF F+SGNF2>F2 THEN 190
530 GOTO 250
540 REM
550 REM          CHECK DIAL ACCURACY
560 REM
570 READ F1
580 IF F1=0 THEN 720
590 DISP "SET TO F1:"MHZ"
600 STOP
610 REM READ FREQUENCY.
620 GOSUB 1530
630 REM COMPARE AGAINST 3% SPEC.
640 IF ABS((F-F1)/F1)<.03 THEN 570
650 E=1
660 PRINT "FREQ ACCURACY OUT OF SPEC AT F1:"MHZ"
670 PRINT " MEASURED FREQ="F1"MHZ"
680 GOTO 570
690 REM
700 REM          MEASURE AM
710 REM
720 REM STORE REFERENCE VALUE WITH AM OFF.
730 CMD "?U1","A12"
740 REM WAIT FOR POWER METER TO SETTLE.
750 WAIT 2000
760 CMD "?U","9+AT","?MS"
770 ENTER (13,320)P1
780 FOR I=20 TO 80 STEP 20
790 REM SET AM DEPTH; COMPARE WITH SPEC.
800 DISP "SET I1:"% AM"
810 STOP
820 CMD "?U","T","?MS"
830 ENTER (13,320)P
840 M=SQR(2+P1-2)+100
850 REM COMPARE WITH 5% OF READING + 5% SPEC.
860 IF ABS(M-1)<5+1+.05 THEN 900
870 E=1
880 PRINT "AM OUT OF SPEC AT I1:"% " ;
890 PRINT "MEASURED VALUE="M1%"
900 NEXT I

```

```

910 REM
920 REM          CHECK STEP ATTENUATOR
930 REM
940 DISP "SET STEP ATTENUATOR TO +10 DBM"
950 STOP
960 REM SET REFERENCE VALUE.
970 CMD "?U","CT"
980 REM TAKE READINGS RELATIVE TO REFERENCE.
990 CMD "?U","B"
1000 FOR I=10 TO 30 STEP 10
1010 DISP "DECREASE ATTENUATOR ONE STEP"
1020 STOP
1030 CMD "?U","T","?MS"
1040 ENTER (13,320)P
1050 IF ABS(I+P)<.5 THEN 1090
1060 E=1
1070 PRINT "ATTENUATOR OUT OF SPEC AT I1:"DBM"
1080 PRINT " MEASURED ATTENUATION="I-P;"DB"
1090 NEXT I
1100 IF E=1 THEN 1130
1110 PRINT "INSTRUMENT PASSED"
1120 PRINT
1130 RESTORE
1140 DISP "CONNECT NEW INSTRUMENT"
1150 STOP
1160 GOTO 80
1170 END
1180 REM -----END OF TESTS-----
1190 REM POWER SENSOR CAL FACTOR AND BAND LIMITS
1200 REM FOR FLATNESS TEST.
1210 DATA 0,99
1220 DATA 10,-19
1230 DATA 35,-19
1240 DATA 35,66
1250 DATA 130,-66
1260 DATA 130,270
1270 DATA 520,-270
1280 DATA 0,0
1290 REM FREQUENCY SETTINGS FOR FREQUENCY SCALE TEST.
1300 DATA 15,20,50,100,200,400,0
1310 REM
1320 REM          POWER METER ZERO AND
1330 REM          COUNTER INITIALIZE SUBROUTINE.
1340 REM
1350 FORMAT B
1360 OUTPUT (13,1350)7681
1370 REM SET SWITCH TO TURN OFF POWER.
1380 CMD "?U1","B12"
1390 REM ZERO POWER METER.
1400 CMD "?U","Z11","?MS"
1410 FORMAT 4#,F4.0
1420 ENTER (13,1410)Z
1430 IF ABS(Z)>.2 THEN 1400
1440 CMD "?U","9+D1","?MS"
1450 ENTER (13,1350)R
1460 IF R >= 84 THEN 1440
1470 REM INITIALIZE COUNTER.
1480 CMD "?U2","2PKMOH"
1490 CMD "?RS"
1500 FORMAT 2#,E12.0
1510 ENTER (13,1500)F
1520 RETURN
1530 REM
1540 REM          COUNTER READ SUBROUTINE
1550 REM
1560 CMD "?U2","I","?RS"
1570 ENTER (13,1500)F
1580 F=F/1E+06
1590 RETURN

```

SECTION 6

Gain and Attenuation Measurements

Description

The programmable features and low mismatch of the 436A Power Meter and its associated sensors allows gain and loss measurements to be made at hundreds of frequencies in less than one minute with accuracies approaching ± 0.6 dB. By using a second 436A Power Meter and a 11667A Power Splitter, source SWR can be dramatically reduced, improving typical accuracies to better than ± 0.2 dB*.

The procedure and sample program presented in the following paragraphs show how to make highly accurate measurements of attenuation. Extension to measurements of gain is straightforward. Although capable of measuring up to 50 dB of attenuation in theory, this method is best suited for measurements of 30 dB or less. To measure up to 70 dB of attenuation, read the paragraphs in this section titled **Additions to the basic measurement**.

Equipment

- Two 436A (Option 022) Power Meters
- Two 8481A Series Power Sensors (Other 8480 power sensors can be used depending on frequency and power range of interest)
- One 11667A Power Splitter
- One 8660A (Option 005) or 8660C (Option 005) Synthesized Signal Generator (110 kHz to 2.6 GHz depending on RF plug-in)
- One 9830A Calculator
- One 9866A Thermal Printer
- One 59405A (Option 030) HP-IB Calculator Interface

Optional

For measurements above 2600 MHz, replace 8660A/C with 8620C (Option 011) Sweep Generator (3 MHz to 18 GHz, depending on RF plug-in).

Procedure

- 1) Rewire power meter number 2 for talk address "L" and listen address "," as shown in Figure 8. (Refer to 436A Operating and Service Manual for more complete details).
- 2) Connect equipment as shown in Figure 9. Set signal generator for maximum power output.
- 3) Connect power meter number 1 directly to power splitter.
- 4) Measure the power level (in dBm) at each power meter and record the difference (in dB).
- 5) Repeat step 4 at each frequency of interest. The system frequency response has now been recorded.
- 6) Connect the device to be tested, as shown in Figure 9.
- 7) Repeat step 4 at each frequency of interest.

- 8) Compute the attenuation of the device under test.

$$A = (P_1 - P_2) - (P_1' - P_2')$$

where

P_1 = calibration reading on power meter number 1, in dBm

P_2 = calibration reading on power meter number 2, in dBm

P_1' = test reading on power meter number 1, in dBm

P_2' = test reading on power meter number 2, in dBm.

The program listed at the end of this section uses this procedure to measure attenuation.

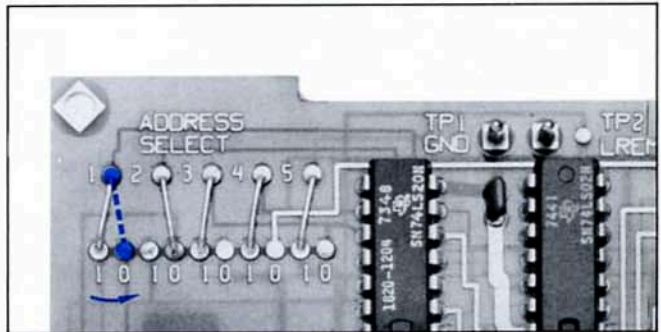

Figure 8. One jumper must be rewired to set the power meter to listen address "L," and talk address "L".

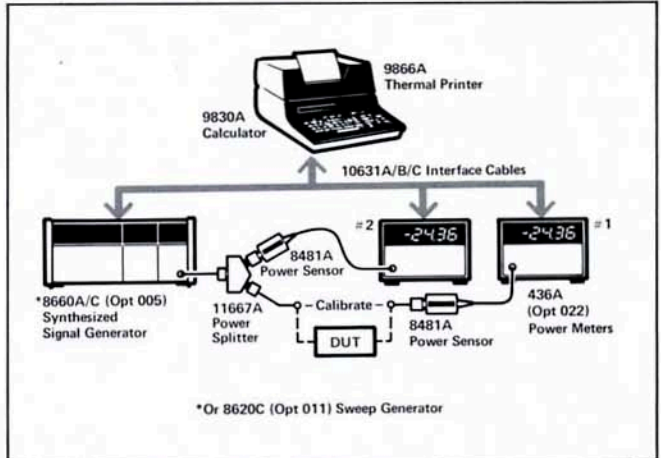

Figure 9. System for measuring attenuation over a 0 to 30 dB range.

Measurement Evaluation

This is a very accurate measurement technique because almost all major errors, except mismatch, are calibrated out in steps 4 and 5. Mismatch can be calculated using the multiple mismatch equation or the calculator program given in Appendix B. Typical mismatch uncertainty for a source SWR = 1.10, a sensor SWR = 1.10, a pad SWR = 1.30, and a pad attenuation of 10 dB is ± 0.11 dB. Instrumentation will typically add ± 0.02 dB to the total error. On the top range only, sensor non-linearity adds ± 0.06 dB.

* For a discussion on the use of a power splitter to reduce source SWR, see Application Note 183, **High Frequency Swept Measurements**, Appendix A.

Additions to the basic measurement

As previously discussed, this technique is best suited for attenuation measurements of 30 dB or less. However, measurements of attenuation levels from 30 to 70 dB can be made by taking advantage of the 8484A Power Sensor's high sensitivity. The procedure is the same as before, except that the 8484A is connected to power meter number 1 in Figure 9 and the calibration run, outlined in steps 4 and 5, is done at a power level of -22 dBm, i.e., somewhere in the top end of the -20 to -30 dBm power range that the 8481A and 8484A have in common.

During the actual test, the source power is increased back to maximum power output. This power change does not affect measurement accuracy because both arms of the power splitter "see" the same power change. Once the power is increased, up to 70 dB of attenuation can be inserted at the test port of the power splitter without exceeding the range of the 8484A.

For "continuous" measurements of attenuation from 0 to 70 dB (e.g., sweep testing filters), a switch may be added as shown in Figure 10. For this set-up, two calibration runs are required, one for each switch position.

During the measurement phase of the cycle, the 8484A sensor is switched into the circuit when the power falls below about -23 dBm and the 8481A sensor is switched into the circuit when the power goes above approximately -21 dBm.

The loss of the switch is automatically calibrated out during the calibration run. However, mismatch seen

looking back into port 3 of the switch is slightly worse than with the sensor alone.

The equivalent reflection coefficient at port 3 of the switch, when port 1 is connected is

$$\Gamma_{EQ} = \Gamma_3 + \frac{T_1^2 \Gamma_L}{1 - \Gamma_1 \Gamma_L}$$

where:

- Γ_3 = reflection coefficient at port 3 with port 1 terminated in a perfect load
- Γ_1 = reflection coefficient at port 1 with port 3 terminated in a perfect load
- Γ_L = reflection coefficient of sensor connected to port 1
- T_1 = ratio of power entering port 3 to power leaving port 1, or vice versa.

The equivalent reflection coefficient at port 3, when port 2 is connected can be found from the above equation by substituting the subscript 2 for the subscript 1.

9830A Calculator program

The following is a 9830A Calculator program for measuring attenuation in the 0 to 30 dB range. This program follows the procedure outlined in the previous paragraphs.

Although this program is written for the 8660C (Option 005) Synthesized Signal Generator, it could easily be used with an 8620C (Option 011) Sweep Generator to generate frequencies up to 18 GHz. The frequency control subroutine would, of course, need to be changed.

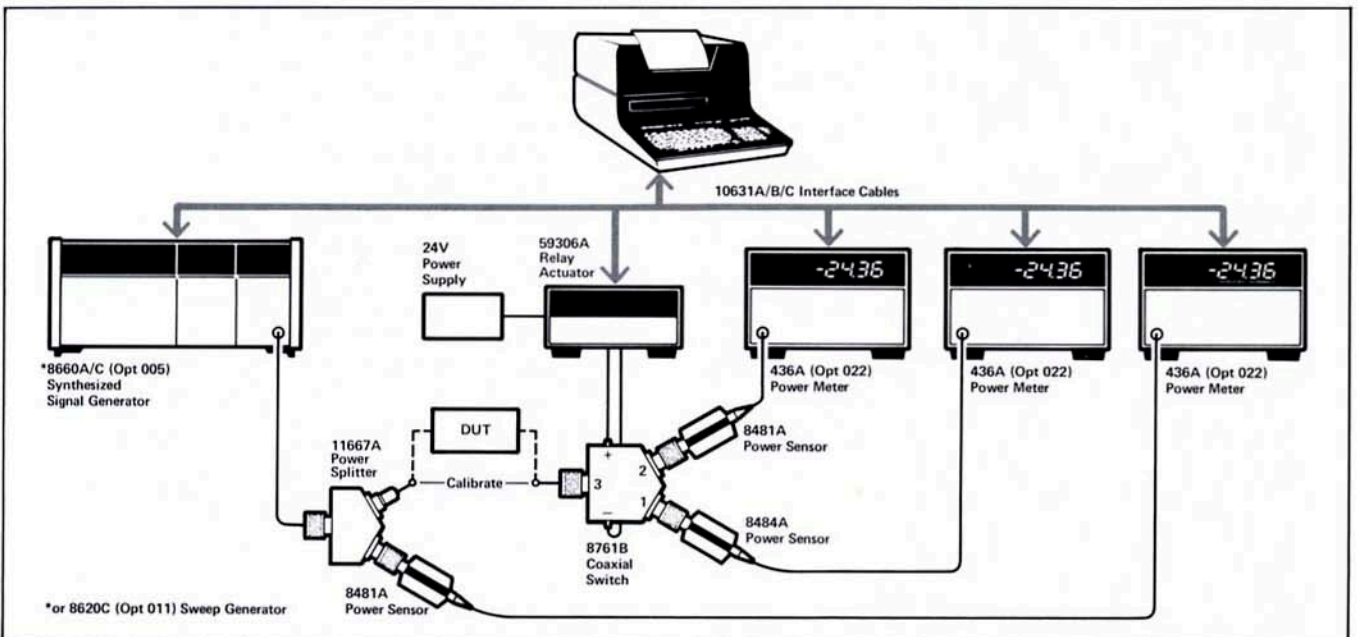

Figure 10. System for measuring attenuation over a 0 to 70 dB range using the 8481A and 8484A Power Sensors. See inset on Figure 7 for details of 8761B switch connection.

Attenuation Measurement Program for 9830A Calculator

```

10 REM----- ATTENUATION MEASUREMENT PROGRAM -----
20 REM
30 REM SIGNAL GENERATOR LISTEN "G"
40 REM TEST POWER METER LISTEN "-" TALK "H"
50 REM REFERENCE POWER METER LISTEN "+" TALK "L"
60 REM
70 DIM PSI(100)
80 REM
90 REM     INPUT DATA
100 REM
110 REM SPECIFY FREQUENCY RANGE AND NUMBER OF POINTS.
120 DISP "START FREQUENCY (MHZ)?"
130 INPUT F1
140 DISP "STOP FREQUENCY (MHZ)?"
150 INPUT F2
160 DISP "NUMBER OF POINTS?"
170 INPUT N
180 REM
190 REM     SYSTEM CALIBRATION
200 REM
210 REM ZERO THE POWER METER:
220 REM SET SIGNAL GENERATOR OUTPUT LEVEL.
230 GOSUB 670
240 REM INITIALIZE ARRAY SUBSCRIPT (I).
250 I=1
260 FOR F=F1 TO F2 STEP (F2-F1)/(N-1)
270 REM CHANGE FREQUENCY.
280 GOSUB 920
290 REM MEASURE POWER.
300 GOSUB 1070
310 REM STORE RESULTS.
320 P(I)=P
330 I=I+1
340 NEXT F
350 REM
360 REM     MEASURE ATTENUATION
370 REM
380 REM CONNECT DEVICE TO BE TESTED.
390 DISP "CON. DEVICE? PRESS CONT+EXECUTE?"
400 STOP
410 REM INITIALIZE ARRAY SUBSCRIPT.
420 I=1
430 REM RE-ZERO POWER METER.
440 GOSUB 670
450 PRINT
460 FOR F=F1 TO F2 STEP (F2-F1)/(N-1)
470 REM CHANGE FREQUENCY AND MEASURE POWER.
480 GOSUB 910
490 GOSUB 1070
500 REM USE PREVIOUS POWER READING TO CORRECT
510 REM FREQUENCY RESPONSE ERRORS.
520 P=PI(I)-P
530 I=I+1
540 FIXED 4
550 PRINT "FREQUENCY=";F;
560 FIXED 2
570 PRINT TAB(21);"MHZ";TAB(30);"ATTENUATION=";
580 PRINT TAB(48);"DB"
590 NEXT F
600 PRINT
610 GOTO 380
620 REM ----- END OF TEST -----

```

```

630 REM
640 REM     POWER METER ZERO AND
650 REM     GENERATOR LEVEL SET SUBROUTINE
660 REM
670 FORMAT B
680 OUTPUT (13,670)760;
690 REM TURN GENERATOR OUTPUT POWER "OFF" (-130 DBM).
700 CMD "2U3";"/341C"
710 REM ZERO POWER METER ON MOST SENSITIVE RANGE.
720 CMD "2U+";"Z11"
730 FORMAT 4X,F4.0
740 CMD "2H5"
750 ENTER (13,730)Z
760 CMD "2L5"
770 ENTER (13,730)Z1
780 REM IF POWER METER IS NOT NEAR ZERO,
790 REM TAKE ANOTHER MEASUREMENT.
800 IF (ABSZ>2) OR (ABSZ1>2) THEN 720
810 REM CHECK FOR END OF ZERO.
820 CMD "2U+";"9+D1"
830 CMD "2H5"
840 ENTER (13,670)A
850 CMD "2L5"
860 ENTER (13,670)B
870 IF A >= 84 OR B >= 84 THEN 820
880 REM SET 8660 LEVEL TO +13 DBM.
890 CMD "2U3";"/C"
900 RETURN
910 REM
920 REM     8660 FREQUENCY CONTROL SUBROUTINE
930 REM
940 FORMAT F1000.0;"C"
950 CMD "2U3"
960 OUTPUT (13,940)FNI(INT(F*1E+06)/1E+09)
970 RETURN
980 DEF FNI(X)
990 N=1
1000 Y=ABSX
1010 Z=0
1020 Z=Z+N*INTY
1030 Y=10*(Y-INTY)
1040 N=10*N
1050 IF Y#0 THEN 1020
1060 RETURN Z
1070 REM
1080 REM     POWER METER READ SUBROUTINE.
1090 REM     RETURN RATIO (DIFFERENCE IN DB) OF
1100 REM     TEST POWER TO REFERENCE POWER.
1110 REM
1120 REM TRIGGER BOTH METERS SIMULTANEOUSLY.
1130 REM 0 IS FLAG TO SIGNIFY POWER READING
1140 REM ON BOTTOM RANGE.
1150 O=0
1160 CMD "2U-";"T"
1170 CMD "2H5"
1180 FORMAT 1X,B;1X,E12.0
1190 ENTER (13,1180)A;P1
1200 CMD "2L5"
1210 ENTER (13,1180)B;P2
1220 IF A#73 AND B#73 OR O=1 THEN 1280
1230 REM IF POWER READING IS ON BOTTOM RANGE,
1240 REM THEN WAIT AN ADDITIONAL 10 SECONDS.
1250 O=1
1260 WAIT 10000
1270 GOTO 1160
1280 P=P1-P2
1290 RETURN
1300 END

```

SECTION 7

Power Sensor Calibration

Description

The accuracy of a power sensor's calibration factor directly affects power measurement accuracy. It is therefore good practice to periodically check cal factor to verify that it has not changed due to sensor damage or aging.

The following procedure is a very simple, yet effective, way of transferring the calibration factor of a standard power sensor to a particular unit under test. This technique relies on a broadband resistive power splitter and a second power meter to cancel out power variations in the source and, more importantly, reduce source mismatch to a very low value. By alternately connecting the standard power sensor and the sensor under test to this leveled source, the calibration factor of the standard can be transferred to the test unit.

The calculator program listed at the end of this section shows how to automatically perform this calibration for an 8481A, 8482A or 8483A Power Sensor. Extension of this technique to other 8480 sensors only requires a change in power levels.

The paragraphs on **Additions to the basic measurement** outline a technique that could be used to calibrate power sensors for power meters other than the 436A.

Equipment

- Two 436A (Option 022) Power Meters
- Two 8480 Series Power Sensors (one of these should preferably be calibrated by a standards lab)
- One 11667A Power Splitter

- One 8660A (Option 005) or 8660C (Option 005) Synthesized Signal Generator (110 kHz to 2.6 GHz depending on RF plug-in)
- One 9830A Calculator
- One 9866A Thermal Printer
- One 59405A (Option 030) HP-IB Calculator Interface.

Optional

For measurements above 2600 MHz, replace 8660A/C with 8620C (Option 011) Sweep Generator (3 MHz to 18 GHz depending on plug-in).

Procedure

- 1) Rewire power meter number 2 for talk address "L" and listen address "I," as shown in Figure 8 (refer to 436A Operating and Service Manual for more complete details).
- 2) Connect equipment as shown in Figure 11.
- 3) Connect standard 8480 Series Power Sensor to power meter number 2 reference oscillator and vary **cal adj** for a stable 1.000 mW reading.
- 4) Take readings from both power meters at the frequencies of interest. Store the ratio [power number 2 (watts)]/[power number 1 (watts)]. Call this ratio P1.
- 5) Repeat steps 3 and 4 above, except substitute the 8480 Series sensor to be tested for the 8480 standard. Call the ratio in step 4 P2.

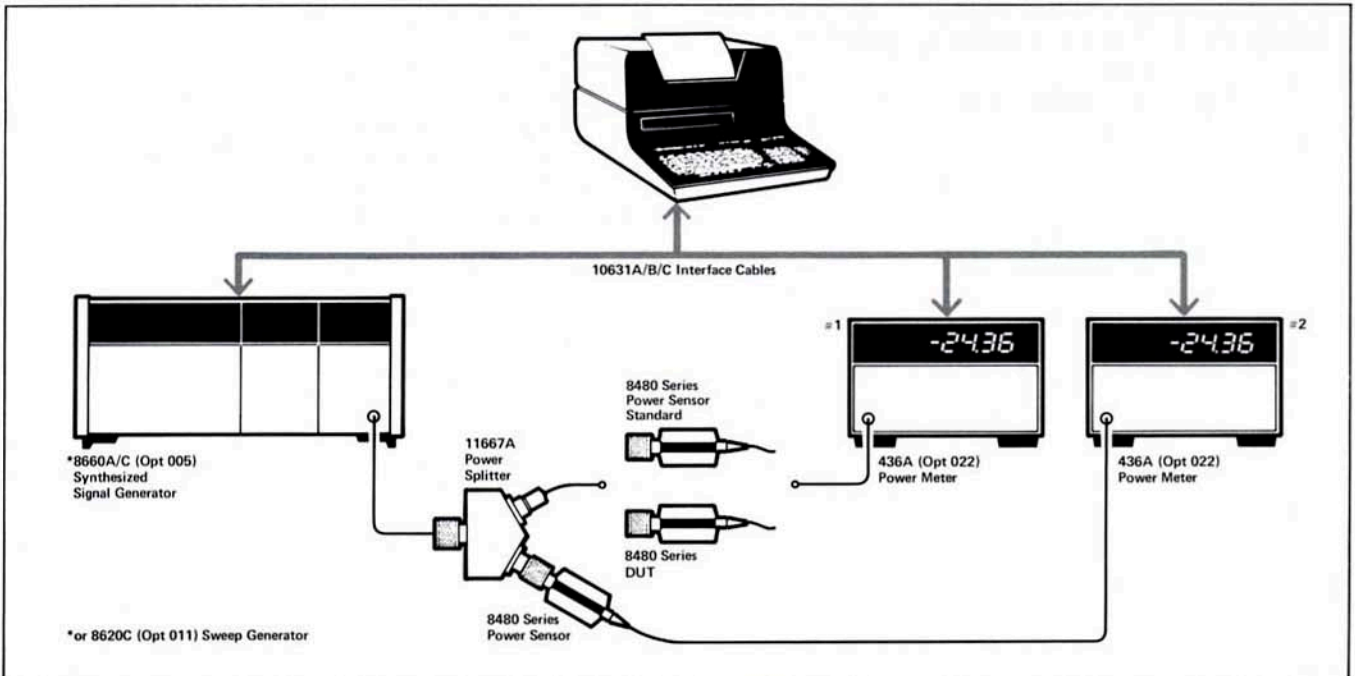

Figure 11. System for transferring calibration factor from one 8480 Series power sensor to another.

6) Compute the calibration factor of the unknown sensor at each frequency: $K_u = K_s \frac{P_2}{P_1}$ 7-1

where:

K_u = unknown's calibration factor

K_s = standard's calibration factor.

Measurement evaluation

The accuracy of this measurement depends on four factors:

Standard's calibration factor uncertainty

The calibration factor uncertainty of the standard sensor is specified by the user's standards lab. If a production 8480 Series power sensor is used, this uncertainty is specified in the data sheet.

Mismatch uncertainty

Measurement mismatch uncertainty is given by

$$(1 \pm |\Gamma_s| |\Gamma_G|) (1 \pm |\Gamma_u| |\Gamma_G|) \quad 7-2$$

where: Γ_G = generator's equivalent reflection coefficient

Γ_s = standard's reflection coefficient

Γ_u = unknown's reflection coefficient.

Plus and minus one count error

Plus and minus 1 count error is the error caused by a 1 count change in the least significant digit of the reading.

Power meter reference oscillator mismatch uncertainty

Reference oscillator mismatch uncertainty is given by

$$(1 \pm |\Gamma_R| |\Gamma_s|) (1 \pm |\Gamma_R| |\Gamma_u|) \quad 7-3$$

where: Γ_R = reference oscillator's reflection coefficient.

Γ_s, Γ_u are defined above.

Total uncertainty can be computed using the rules outlined in the last paragraph in Section 1, i.e., first find total uncertainty for each power measurement, and then multiply these uncertainties (or convert to dBm and add) to obtain the uncertainty in the final result.

Additions to the basic measurement

This same technique can be used with other power meters besides the 436A. However, because most other power meters are not programmable, an HP-IB compatible digital voltmeter such as the HP 3490A or HP 5306A must be connected to the power meter's recorder output.

The measurement is the same as the one outlined previously for the 436A, except that the power meter's range must be set manually, and the calculator must convert the voltage reading into a power reading.

9830A Calculator program

The following is a 9830A Calculator program for calibrating 8481A, 8482A and 8483A Power Sensors. Calibration of other 8480 Series power sensors is possible if the source power level is changed appropriately.

Although this program is written for the 8660C (Option 005) Synthesized Signal Generator, it could easily be used with an 8620C (Option 011) Sweep Generator to generate frequencies up to 18 GHz. The frequency control subroutine would, of course, need to be changed.

The program also computes total uncertainty based on mismatch, plus and minus one count ambiguity, and the uncertainty of the standard.

Power Sensor Calibration Program for 9830A Calculator

```

10 REM-----POWER METER MOUNT CALIBRATION-----
20 REM
30 REM REF POWER METER SET FOR LISTEN "L" TALK "L".
40 REM TEST POWER METER SET FOR LISTEN "L" TALK "M".
50 REM SIGNAL GENERATOR SET FOR LISTEN "3"
60 FORMAT B
70 FORMAT 4,F4.0,X,F0.0
80 DIM F(20),P(20),K(20),S(20),D(20),U(20)
90 REM ZERO POWER METER.
100 GOSUB 1310
110 REM SET 8660 POWER LEVEL.
120 L1=5
130 GOSUB 1120
140 REM
150 REM INPUT DATA
160 REM
170 REM ENTER NEXT FREQUENCY, STANDARD'S CAL FACTOR,
180 REM CAL FACTOR UNCERTAINTY AND SOURCE'S SWR.
190 REM END INPUT SEQUENCE WITH A NEGATIVE FREQUENCY.
200 FOR I=1 TO 20
210 DISP "NEXT TEST FREQUENCY(IN MHZ)?"
220 INPUT F(I)
230 IF F(I)<0 THEN 390
240 DISP "STANDARD'S CAL FACTOR?"
250 INPUT K(I)
260 DISP "CAL FACTOR UNCERTAINTY(%)?"
270 INPUT U(I)
280 DISP "STANDARD'S SWR?"
290 INPUT S(I,1)
300 DISP "SOURCE'S SWR?"
310 INPUT S(I,2)
320 DISP "UNKNOWN'S WORST CASE SWR?"
330 INPUT S(I,3)
340 NEXT I
350 REM
360 REM SYSTEM CALIBRATION
370 REM
380 REM READ POWER RATIO AT EACH TEST FREQUENCY.
390 I1=1
400 FOR I=1 TO I1
410 REM CHANGE FREQUENCY.
420 GOSUB 1050
430 REM WAIT FOR MOUNT TO SETTLE LAST 1%.
440 WAIT 200
450 REM STORE RATIO OF STANDARD TO REF IN P(I).
460 P(I)=FNP(I)
470 REM D(I,1) AND D(I,2) WILL CONTAIN TOTAL
480 REM +- 1 COUNT ERROR.
490 D(I,1)=T1
500 D(I,2)=T2
510 NEXT I
520 REM
530 REM MEASURE CAL FACTOR
540 REM
550 REM STOP AND CONNECT SENSOR TO BE TESTED.
560 DISP "CON. UNKNOWN-PRESS CONT+EXECUTE"
570 CMD "2"
580 OUTPUT (13,60)1024#
590 STOP
600 REM ZERO POWER METER.
610 GOSUB 1310
620 REM SET 8660 POWER LEVEL.
630 L1=5
640 GOSUB 1120
650 PRINT TAB(30)"CAL FACTOR"
660 PRINT
670 FOR I=1 TO I1
680 REM CHANGE FREQUENCY.
690 GOSUB 1050
700 REM WAIT FOR MOUNT TO SETTLE LAST 1%.
710 WAIT 200
720 F2=FNP(I)
730 P1=P(I)
740 REM COMPUTE CAL FACTOR FOR THIS FREQUENCY
750 K=(K(I)+F2/P1
760 F1=ED I
770 PRINT "FREQUENCY="F(I):"CAL FACTOR="K(I)
780 REM
790 REM COMPUTE UNCERTAINTY LIMITS
800 REM
810 PRINT "+-":
820 S=SE I,1
830 G=SE I,2
840 U=SE I,3
850 REM E1+E2 ARE MISMATCH TERMS.
860 E1=((G+S+1)*(U+1))/(G+U)/(S+1)+2
870 E2=((G+S)*(U+1)/(G+U+1)/(S+1)+2
880 REM D1 AND D2 ARE +- 1 COUNT ERRORS.
890 D1=D(I,1)-T2-1
900 D2=D(I,2)-T1-1
910 REM
920 REM TOTAL ERROR =
930 REM (STD UNC.)*(E2/P1 ERROR)+(REF OSC ERROR).
940 REM REF OSC ERROR IS TYPICALLY 0.56%
950 REM DUE TO REF OSC AND POWER SENSORS' SWR.
960 REM AND +- 1 COUNT ERROR.
970 REM
980 PRINT ((U(I)/100+1)*(E1+D1)*1.0056-1)*100#
990 PRINT ((1-U(I)/100)*(E2+D2)*0.9944-1)*100#
1000 NEXT I
1010 GOTO 560
1020 END
1030 REM ----- END OF TEST -----

```

```

1040 REM
1050 REM 8660 FREQUENCY CONTROL SUBROUTINE
1060 REM
1070 FORMAT F1000.0,"C"
1080 CMD "2U3"
1090 OUTPUT (13,1070)FNI(F(I)/1E+03)
1100 RETURN
1110 REM
1120 REM 8660 LEVEL CONTROL
1130 REM
1140 FORMAT "F1000.0,"C"
1150 CMD "2U3"
1160 OUTPUT (13,1140)FNI((L1-13)/1E+02)
1170 RETURN
1180 REM
1190 REM 8660 DIGIT INVERSION SUBROUTINE
1200 REM
1210 DEF FNI(X)
1220 W=1
1230 Y=ABS X
1240 Z=0
1250 Z=Z+W+INT Y
1260 Y=10*(Y-INT Y)
1270 W=10*W
1280 IF Y#0 THEN 1250
1290 RETURN Z
1300 REM
1310 REM POWER METER ZERO SUBROUTINE
1320 REM
1330 OUTPUT (13,60)768#
1340 REM TURN POWER "OFF" (-130 DBM).
1350 L1=-130
1360 GOSUB 1120
1370 CMD "2U+,"ZII"
1380 CMD "2M5"
1390 ENTER (13,70)Z
1400 CMD "2L5"
1410 ENTER (13,70)Z1
1420 REM IF POWER METER IS NOT NEAR ZERO,
1430 REM TAKE ANOTHER MEASUREMENT.
1440 IF (ABS Z)2) OR (ABS Z1)2) THEN 1370
1450 CMD "2U+,"Z+R1"
1460 CMD "2M5"
1470 ENTER (13,60)R
1480 CMD "2L5"
1490 ENTER (13,60)B
1500 REM IF POWER METER IS NOT AT END OF ZERO.
1510 REM CHECK AGAIN.
1520 IF A >= 84 OR B >= 84 THEN 1450
1530 RETURN
1540 REM
1550 REM POWER METER READ FUNCTION.
1560 REM RETURN RATIO OF TEST TO REF POWER.
1570 REM
1580 DEF FNP(X)
1590 REM TRIGGER BOTH METERS SIMULTANEOUSLY.
1600 CMD "2U+,"T"
1610 CMD "2M5"
1620 REM READ MANTISSA AND EXPONENT SEPARATELY.
1630 REM SO THAT +- 1 COUNT ERRORS CAN BE COMPUTED.
1640 ENTER (13,70)P,G1
1650 CMD "2L5"
1660 ENTER (13,70)R,G2
1670 REM COMPUTE +- 1 COUNT ERROR.
1680 T1=(1+P)/(1-R)
1690 T2=(1-P)/(1+R)
1700 REM COMPUTE RATIO OF P/R.
1710 Z=P+10*(G1)/R-10*(G2)
1720 RETURN Z

```

SECTION 8

Other Automated Power Measurements

This section presents a list of ideas for other automated systems which could be built using the 436A Power Meter, a 9820A or 9830A Calculator, and a small number of other instruments. These applications are either too complex or too specialized to be covered in detail in this application note.

Reflection/transmission measurements

Use two 436A Power Meters, a 8660A/C Synthesized Signal Generator (or a 8620C Sweep Generator), and two directional couplers to make automatic, high resolution, reflection and transmission measurements. The ability of the power meter to read true power regardless of waveform makes this a good technique to use if the stimulus signal is amplitude modulated.

Power output vs. applied voltage

Use the HP 59303A D/A Converter and a 436A Power Meter both under calculator control, to measure power out as a function of voltage in. This could be useful for measuring amplifier a.g.c. loop gain, or for testing TWT amplifiers or signal generator AM modulators.

Power drift with time

Use the HP 59308A Timing Generator or the HP 59309A ASCII Digital Calendar/Clock along with the 436A Power Meter to make highly accurate measurements of power drift with time.

Remote power measurements

Use the HP 59403A HP-IB/Common Carrier Interface, a modem, and the 436A Power Meter under calculator

control to transmit power measurements over the telephone lines.

Noise figure measurement

Use the 8660A/C Synthesized Signal Generator (or a 8620C Sweep Generator) and a 436A Power Meter to make noise figure measurements.

To measure noise figure, first measure the power gain vs. frequency of the device under test using the procedure outlined in Section 6. Next, use the calculator to integrate this response curve to obtain the device's gain-bandwidth product (GB). Finally, terminate the device's input with its characteristic impedance and use the power meter to measure total noise power output (N_1). Noise figure is then computed as:

$$F = N_1/kT_0 \text{ GB}$$

where N_1 and GB are defined above and

F = noise figure

k = Boltzman's constant, 1.374×10^{-23} joule/°K

T_0 = absolute temperature of device's input, °K.

Application Note 57, **Noise Figure Primer**, contains more information on noise measurements.

APPENDIX A

Measuring AM Modulation Index With a Power Meter

The power in the carrier of an AM modulated waveform remains constant regardless of the modulation index. Therefore, the increase in sideband amplitude due to an increase in modulation index is reflected directly in a power increase of the total signal.

For a sinewave modulated waveform,

$$P_T = P_c + 2P_s \quad \text{A-1}$$

where:

P_T = total power of modulated waveform (in watts)

P_c = power in carrier (in watts)

P_s = power in each of the two sidebands (in watts)

Rearranging equation A-1 yields:

$$P_s = \frac{P_T - P_c}{2} \quad \text{A-2}$$

* For a derivation of this equation see Application Note 150-1, **Spectrum Analysis: Amplitude and Frequency Modulation**, pages 2-3.

Next, the relationship between the AM modulation index and the sideband and carrier amplitudes is:*

$$m = 2 \frac{E_s}{E_c} \quad \text{A-3}$$

where: E_s = voltage of each sideband

E_c = voltage of carrier

Therefore,

$$m^2 = 4 \frac{E_s^2}{E_c^2} = 4 \frac{P_s}{P_c} \quad \text{A-4}$$

Substituting equation A-2 into A-4 yields

$$m^2 = 2 \left(\frac{P_T}{P_c} - 1 \right) \quad \text{A-5}$$

or

$$m = \sqrt{2 \left(\frac{P_T}{P_c} - 1 \right)} \quad \text{A-6}$$

APPENDIX B

Multiple Mismatch

The mismatch uncertainty equation for the measurement set-up shown in Figure 12 is:*

$$\frac{(1 \pm \rho_s \rho_L)}{(1 \pm \rho_s \rho_1) (1 \pm \rho_2 \rho_L) \pm (\rho_s T_1 T_2 \rho_L)} \quad \text{B-1}$$

where:

ρ_s and ρ_L represent the source and sensor reflection coefficients, respectively

ρ_1 and ρ_2 represent the input and output reflection coefficients of the DUT, respectively

T_1 and T_2 are the forward and reverse transmission coefficients of the DUT, respectively.

The numerator is the error encountered during calibration and the denominator is the error encountered during the actual test.

The following program can be used to evaluate the above equation. The program asks for mismatch in terms of SWR instead of reflection coefficient. Also the program assumes that the DUT is bilateral ($T_1 = T_2$) and that $\rho_1 = \rho_2$.

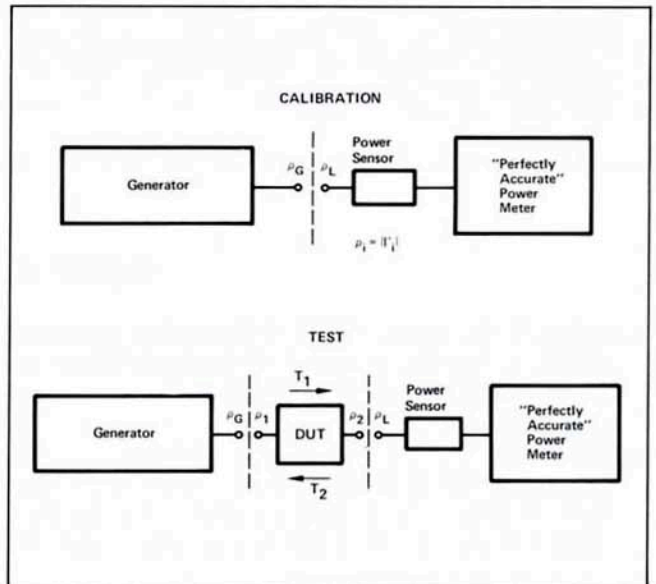

Figure 12. Definition of reflection and transmission coefficients for attenuation measurements using a power meter. Mismatch errors occur at three different measurement planes. Equation B-1 gives the total mismatch uncertainty for this measurement.

*See Application Note 183, **High Frequency Swept Measurements**, P. 44-46.

Multiple Mismatch Program for 9830A Calculator

```
10 REM-----MULTIPLE MISMATCH PROGRAM-----
20 REM      ASSUMES BILATERAL DEVICE,
30 REM      AND EQUAL INPUT AND OUTPUT SWR
40 REM
50 DISP "SOURCE SWR?":
60 INPUT A1
70 DISP "SENSOR SWR?":
80 INPUT B1
90 DISP "PAD SWR?":
100 INPUT C1
110 DISP "ATTENUATION?":
120 INPUT D1
130 REM CONVERT SWR TO REFLECTION COEFFICIENT.
140 A=(A1-1)/(A1+1)
150 B=(B1-1)/(B1+1)
160 C=(C1-1)/(C1+1)
170 REM CONVERT LOGARITHMIC MEASURE (DB) TO RATIO.
180 D=10^(-D1/10)
190 E=1
200 FIXED 2
210 GOSUB 340
220 PRINT "SOURCE SWR=";A1;"LOAD SWR=":
230 PRINT B1;"PAD SWR=";C1;"ATTEN=";D1
240 PRINT "ERROR LIMITS =" ;F1
250 REM COMPUTE MINUS ERROR.
260 E=-1
270 GOSUB 340
280 PRINT F;"DB"
290 PRINT
300 STOP
310 REM
320 REM      MISMATCH EQUATION
330 REM
340 X1=1-A*B+E
350 X2=1+A*C+E
360 X3=1+C*B+E
370 X4=D+B*A+E
380 F=20*LG(X1/(X2*X3+E*X4))
390 RETURN
400 END
```

Additional References

1. Beatty, R. W., **Applications of Waveguide and Circuit Theory to the Development of Accurate Microwave Measurement Methods and Standards**, NBS monograph 137, August 1973.
2. Weinschel, B. O., "Automatic Transformation of Curved-to-Flat Calibration Lines by a Normalizer," IEEE Transactions on Instrumentation and Measurement, vol. IM-18, No. 4, December 1969, p. 307-315.
3. Hewlett-Packard Company, Application Note 56, "Microwave Mismatch Error Analysis."
4. Hewlett-Packard Company, Application Note 187-1, "Configuration of a 2-18 GHz Synthesized Frequency Source."
5. Hewlett-Packard Company, Application Note 187-3, "Three HP-IB Configurations for Making Microwave Scalar Measurements."



For more information, call your local HP Sales Office or East (301) 948-6370 • Midwest (312) 677-0400 • South (404) 434-4000 • West (213) 877-1282. Or, write: Hewlett-Packard, 1501 Page Mill Road, Palo Alto, California 94304. In Europe, Post Office Box 349, CH-1217 Meyrin 1, Geneva, Switzerland. In Japan, Yokogawa-Hewlett-Packard, 1-59-1, Yoyogi, Shibuya-Ku, Tokyo, 151.