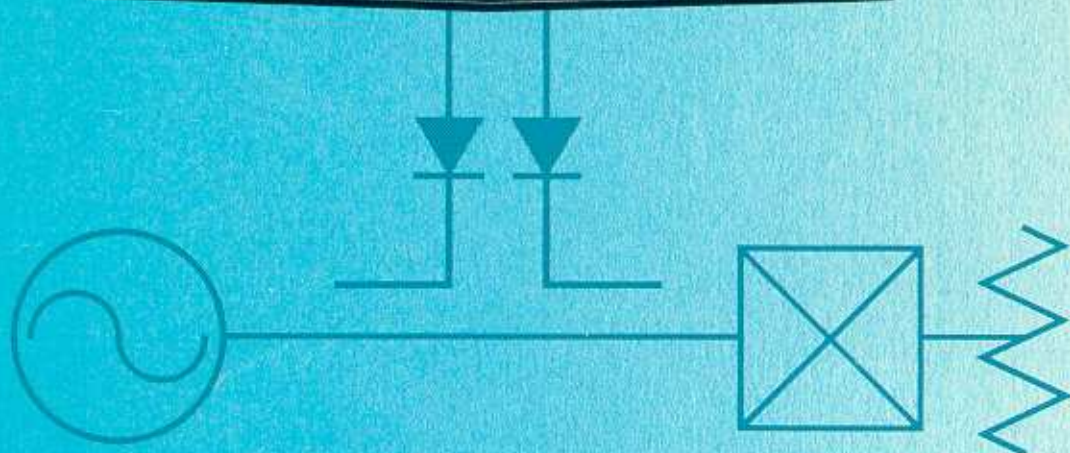
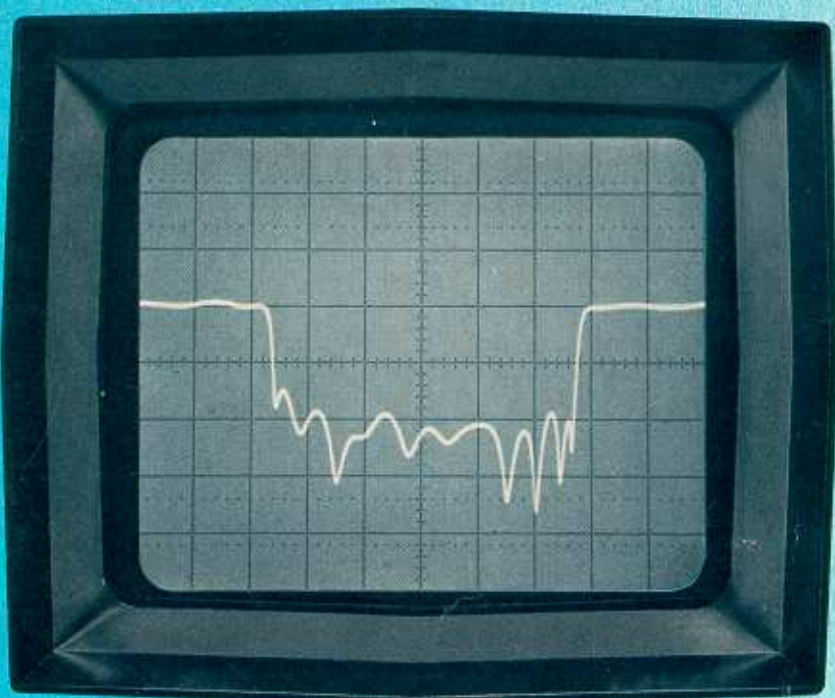


# HIGH FREQUENCY SWEPT MEASUREMENTS



Application Note 183

HEWLETT  PACKARD

**Application Note 183**

**HIGH FREQUENCY  
SWEPT MEASUREMENTS**

*DECEMBER 1978*

**HEWLETT  PACKARD**

# CONTENTS

<b>INTRODUCTION</b> .....	1
History .....	1
Measurement Fundamentals .....	1
Sweep Oscillators .....	1
Detectors .....	6
Displays .....	9
Signal Separation .....	11
<b>IMPEDANCE</b> .....	13
Coax Reflectometer Measurements .....	13
Waveguide Reflectometer Measurements .....	16
Waveguide Reflectometer Measurements with RF Substitution .....	17
Reflectometer Accuracy .....	18
Swept Slotted-Line Measurements .....	19
Swept Slotted-Line Accuracy .....	21
Directivity Measurements .....	21
Source SWR Measurements .....	23
<b>TRANSMISSION</b> .....	25
Coax Transmission Measurements with Directional Couplers .....	25
Coax Transmission Measurements with Power Splitters .....	28
Coax Transmission Measurements Summary .....	29
Coax Comparison Measurements .....	30
Waveguide Transmission Measurements .....	31
Waveguide Transmission Measurements with RF Substitution .....	32
Transmission Measurement Accuracy .....	33
Simultaneous Transmission/Reflection Measurements .....	34
Power Measurements .....	36
Input Power vs. Output Power or Gain .....	37
Power Measurement Accuracy .....	37
<b>APPENDIX</b> .....	39
A Source Match of Leveled or Ratio Systems and Coupler vs. 2- and 3-Resistor Splitters .....	39
B Errors in Reflection Measurements .....	41
C Errors in Transmission Measurements .....	43
Digital Storage and Normalization .....	45
Other Literature on High Frequency Swept Measurements .....	46

# INTRODUCTION

As engineers continue to design and test more complex high-frequency networks, the need for more accurate data over broader bandwidths has become more important. Satisfaction of these data requirements is normally achieved quickly and accurately through the swept measurement of two primary network parameters, impedance and transmission coefficient.

The objective of this application note is the discussion of specific techniques for the swept measurement of

1. Impedance (Reflection Coefficient)
2. Transmission Coefficient.

In the most general sense, impedance and transmission data possess both magnitude and phase characteristics. However, phase information is not required in many general applications, and the techniques discussed here will concentrate on the magnitude characteristics.<sup>1</sup> Besides presentation of specific techniques, information on the accuracy and particular applicability of the various measurement techniques is provided.

## HISTORY

Early impedance and transmission measurements were made at fixed frequencies in a point-to-point fashion. These measurements were tedious, time consuming, and often yielded incomplete results. For instance, resonances between points of measurement were often missed or the skirt responses of filters and amplifiers were inadequately defined.

The evolutionary process of overcoming these difficulties was initiated in 1952 with the introduction of the first broadband, high directivity directional coupler. The ability to separate forward and reverse traveling waves on a broadband basis speeded fixed-frequency reflection and transmission measurements. In 1954 swept-frequency measurements became possible with the introduction of a sweeping signal source using a motor-driven, mechanically-tuned klystron. These instruments combined with ratiometers and broadband detectors to introduce swept measurements as a powerful new methodology for network optimization.

By 1957 the mechanically-tuned klystron had been obsoleted by the voltage-tuned backward wave oscillator tubes (BWO) as a source of swept RF signals. The voltage-tuned BWO's allowed faster and more accurate sweep times while relieving the problems of moding and tracking associated with klystrons. However, BWO's are vacuum-tube devices which burn out after prolonged use. To overcome the finite life problems associated with the BWO, solid-state microwave sweep oscillators were developed in the late 1960's.

Further development has led to the introduction of multi-octave solid-state sources, allowing continuous swept measurements over several octaves of frequency.

Innovations in other areas of swept-measurement technology have complemented the development of sweep oscillators. For instance, multi-octave, high-directivity, coax-directional couplers have been developed at frequencies up to 18 GHz. New diode detectors with more sensitivity can be combined with the appropriate ratiometer display to obtain greater measurement range and increased measurement confidence over broad frequency spans.

## MEASUREMENT FUNDAMENTALS

Four fundamental components are common to all of the swept measurement techniques discussed in this note. These components are:

1. Swept signal source
2. Detectors
3. Displays
4. Signal separation devices.

Understanding the important parameters that control the operation of these components in swept-measurement systems is important in understanding techniques, qualifying system accuracies, and configuring new measurement systems. The major characteristics of swept signal sources, detectors, displays, and signal separation devices are outlined in the remainder of this section.

## SWEEP OSCILLATORS

Sweep oscillators (sweepers) are the most common source of swept RF signals in systems measuring network impedance and transmission characteristics. The major technical features of a sweeper and their importance in qualifying measurements are:

1. Sufficient power output which can be made constant (leveled) over the frequency range of the sweep leads to a wide dynamic range. Leveling is also important in maintaining good source impedance match under a variety of loading conditions.
2. Accurate linear sweeps and calibrated frequency markers are important for frequency determination and horizontal calibration of CRTs and X-Y recorders.
3. RF signal with low spurs and harmonics is required to minimize measurement inaccuracies when broadband detection is used.
4. Frequency stability is necessary for making accurate single-frequency (CW) and narrowband measurements.

<sup>1</sup> Phase measurement is discussed in HP Application Notes 117-1 and 121.

5. Basic operating functions and capabilities are necessary for efficient calibration and measurements. Several capabilities important to swept measurements are the various sweep modes, variable sweep speeds, frequency markers, leveling, and modulation.

Sweep oscillators covering the frequency ranges from 400 kHz to 40 GHz are offered by Hewlett-Packard. The 8620C solid-state sweeper and some of its major features are shown in Figure 1.

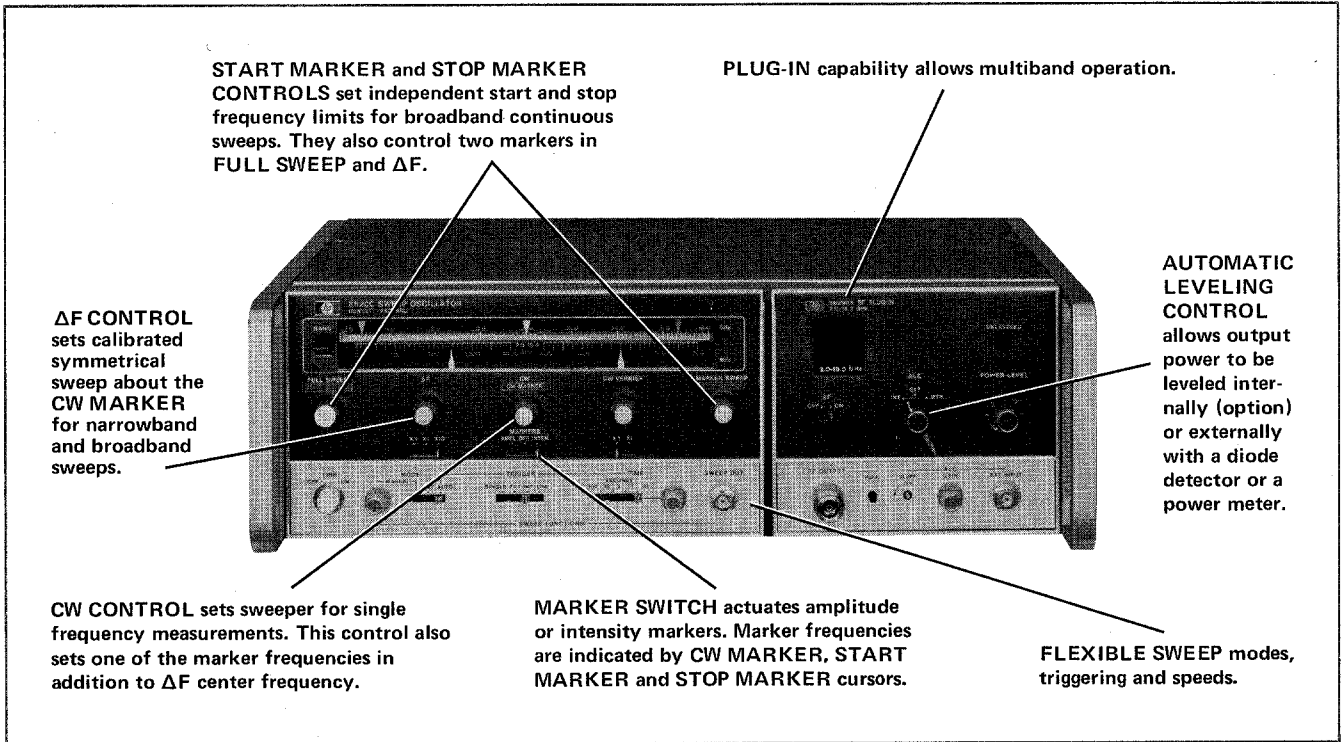


Figure 1. HP 8620C Solid-State Sweep Oscillator. Various plug-in oscillators for the 8620C mainframe operate over the 3 MHz to 18 GHz frequency range. The 86290A RF plug-in (above) covers the 2 to 18 GHz band in a single sweep.

### Leveling Sweepers

The concept of leveling is illustrated by the photographs of unleveled and leveled sweeper outputs in Figures 2 (a) and 2 (b).

Leveling sweeper output accomplishes two major objectives:

1. Output power is held constant as a function of frequency.
2. Output power is held constant as a function of load impedance because source match is improved.

Flatness and a well-matched source are achieved by an automatic leveling circuit (ALC) which is standard on HP 8620 and 8690 Series (BWO) sweepers (see

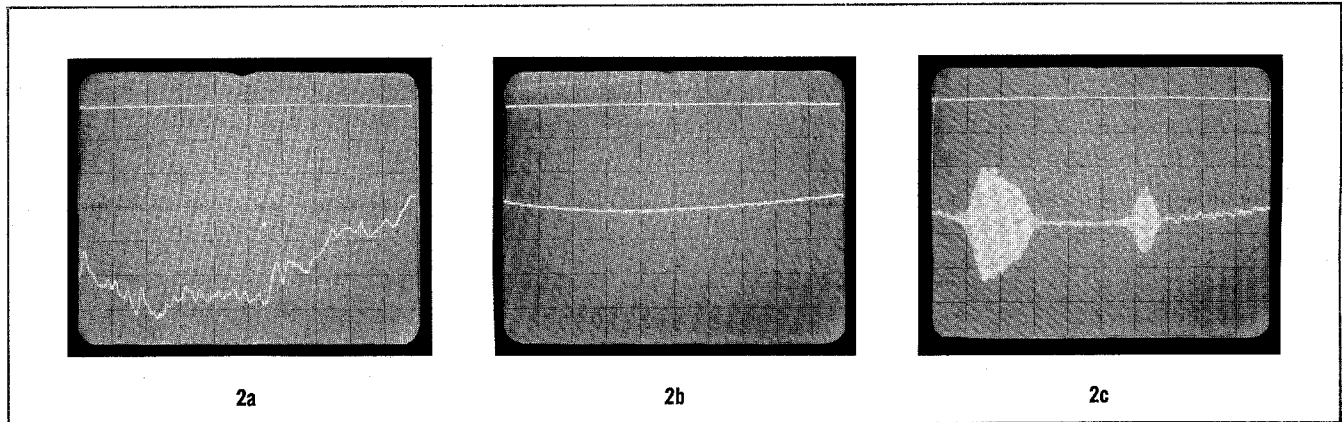
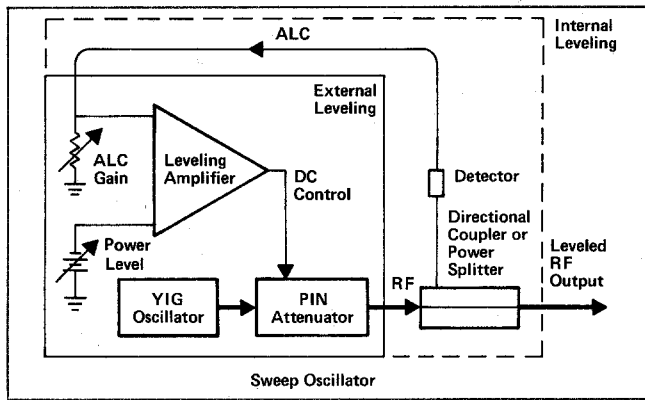


Figure 2. Oscilloscope displays for: (a) unleveled sweeper output resulting from insufficient ALC gain, (b) maximum leveled sweeper output, and (c) oscillations in the leveling feedback loop resulting from excessive ALC gain. From the display it is evident that the maximum leveled power is practically identical to the minimum unleveled power; the remaining variation in leveled output is caused by coupling variation with frequency. Note: Since negative voltage diode detector was used, more power is down.

## DIODE DETECTOR LEVELING



**Figure 3.** Basic automatic leveling circuit (ALC). Internally-leveled sweepers contain the directional coupler and detector (point-contact diode) within the sweeper. Externally-leveled sweepers may use either a directional coupler or a two-resistor power splitter with a point-contact diode or thermistor detector.

Figure 3). A dc feedback voltage is derived from a detector monitoring the sweeper output through the arm of a directional coupler or similar sampler. The directional coupler is arranged so only the forward power will be held constant with frequency and load impedance variation. The leveling amplifier is a differential amplifier comparing the dc feedback voltage to a reference voltage; the dc output of the amplifier is connected to a PIN attenuator which modulates the output power according to the applied voltage. Increasing the leveling amplifier reference voltage calls for more detector voltage, hence more RF output power. The overall loop gain is controlled by a variable resistor (ALC Gain) at the other input to the differential amplifier. Increasing the gain control raises negative feedback, reducing power peaks and improving leveling; too much gain will make the loop unstable and subject to oscillation, Figure 2 (c).

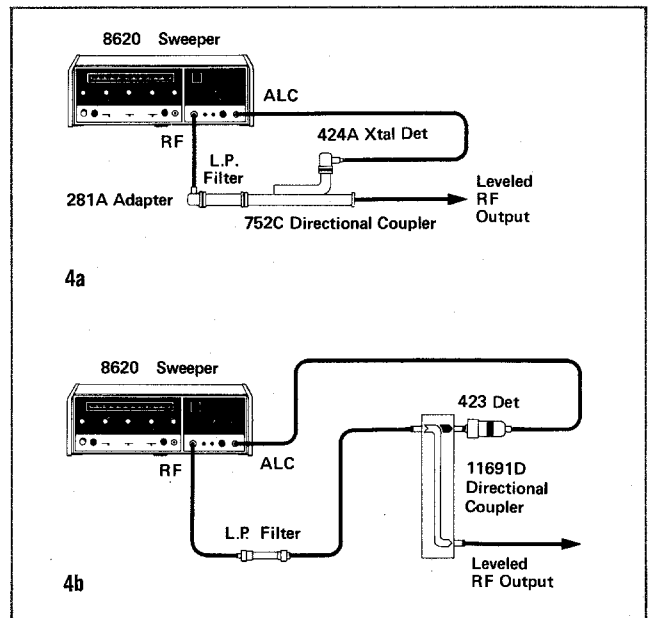
Observing Figures 2 (a) and 2 (b), one can see that the maximum leveled power is very near the minimum **unleveled** power. When the ALC is operating to produce maximum leveled power, the PIN attenuator must absorb any sweeper output in excess of the leveled power setting.

It is now easy to see how leveling improves source match: since the directional coupler in the feedback loop only couples power moving in the forward direction, the ALC will only respond to variation in forward power. Thus no matter what type of load is applied to the leveled sweeper output, the reverse power flow resultant from the load will not affect the ALC or the sweeper output. Reflections from cables, connectors, etc. within the loop are also compensated by the ALC.

Depending on the application, there are a variety of methods for leveling a sweeper. Essentially, a sweeper may be leveled internally by a point-contact diode detector or externally by means of a point-contact diode detector or a power meter. Some of the most common leveling arrangements are shown in Figures 4 through 6. The methods for attaining maximum leveled power and the application of each configuration will be briefly discussed.

**Internal Leveling vs. External Leveling.** Internal leveling's major advantage is its simplicity. No external connections and a minimum of sweeper adjustments are required. It's primary disadvantage is that it is usually farther from the point of measurement than external leveling, thus cable losses and connector mismatch reflections that might have been compensated in an external leveling loop will contribute to measurement inaccuracies. The flatness for most internally leveled microwave sweepers is typically between  $\pm 0.5$  and  $\pm 1$  dB when measured at the output.

To obtain maximum leveled power, turn the ALC switch to INT and the POWER LEVEL maximum (clockwise). Turn the POWER LEVEL down until the UNLEVELED light goes out and the sweeper is set for maximum leveled power.



**Figure 4.** Configurations for externally-leveling sweepers with directional couplers and point-contact diode detectors in a) waveguide (2.6 to 40 GHz) and b) coax (0.1 to 18 GHz). Note: Low-pass filters are utilized to eliminate errors caused by harmonics. An oscilloscope and point-contact diode should be used to monitor the leveled output for undesirable loop oscillations.

Externally leveled sweepers using diode detectors are shown in Figure 4 (a) (waveguide) and in Figure 4 (b) (coax). The procedure for obtaining maximum leveled power is:

1. Set up equipment as shown and set the sweeper for a rapid sweep over the desired frequency range. An oscilloscope and point-contact diode detector should be used to monitor the leveled source output for undesirable loop oscillations.
2. Set ALC to EXT and turn POWER LEVEL and ALC GAIN to maximum (fully clockwise).
3. Decrease POWER LEVEL until UNLEVELED light goes out or oscillations appear on the oscilloscope. If oscillations appear reduce ALC GAIN until oscillations are removed.

4. Repeat step 3 until POWER LEVEL can be continuously adjusted from the minimum to the point just before the UNLEVELED light comes on without oscillations.
5. Set POWER LEVEL to the point just before the UNLEVELED light comes on and the sweeper will be operating at optimum feedback gain and maximum leveled power.

In Figure 5 (a) a 3-dB directional coupler with the secondary arm terminated has been placed between the 10-dB directional coupler and the ALC detector to obtain a super-leveled waveguide system. The inverse coupling characteristic of the 3-dB coupler's main arm compensates for the coupling variation of the 10-dB coupler's auxiliary arm. The net result is the cancellation of coupling variation that would otherwise affect the ALC feedback level. Note: the 3-dB and 10-dB directional couplers must be of similar design and manufacture for cancellation of coupling variation.

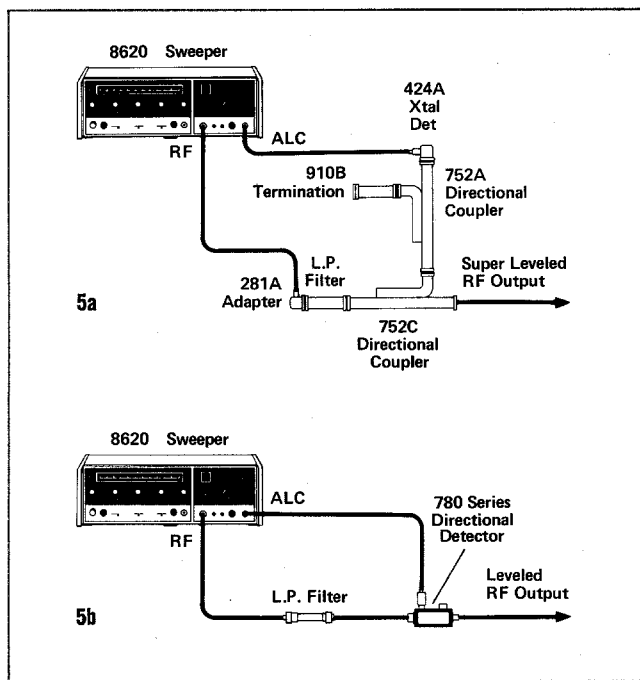


Figure 5. Configurations for a) waveguide super-leveling (2.6 to 40 GHz) and b) coax directional detector (1 to 12.4 GHz). In waveguide super-leveling, the two-coupler arrangement results in mutual compensation of coupling variation with frequency, improving leveling performance. A directional detector is a combination directional coupler and point-contact diode optimizing coupling variation and detector frequency response for improved leveling flatness.

The optimum leveling flatness can be achieved in coax by using an HP 780 Series directional detector as shown in Figure 5 (b). A directional detector, a combination coupler and point-contact diode detector, has been optimized both in terms of coupling variation and detector frequency response to produce a flat RF output. Both the directional detector and the super-leveled waveguide system are leveled by the same procedure as the systems in Figures 4 (a) and 4 (b).

## POWER METER LEVELING

Because of the thermistor's good frequency response, power meter leveling setups like those in Figures 6 (a) and 6 (b) provide consistently flat output over the microwave frequency range. However, thermistors have inherently long thermal time constants, making the effective bandwidth of the power meter leveling loop narrow compared to the diode leveling loop. Consequently, long sweep times (20 to 30 sec/octave) are required for the thermistor to respond to power peaks and the leveling to be effective.

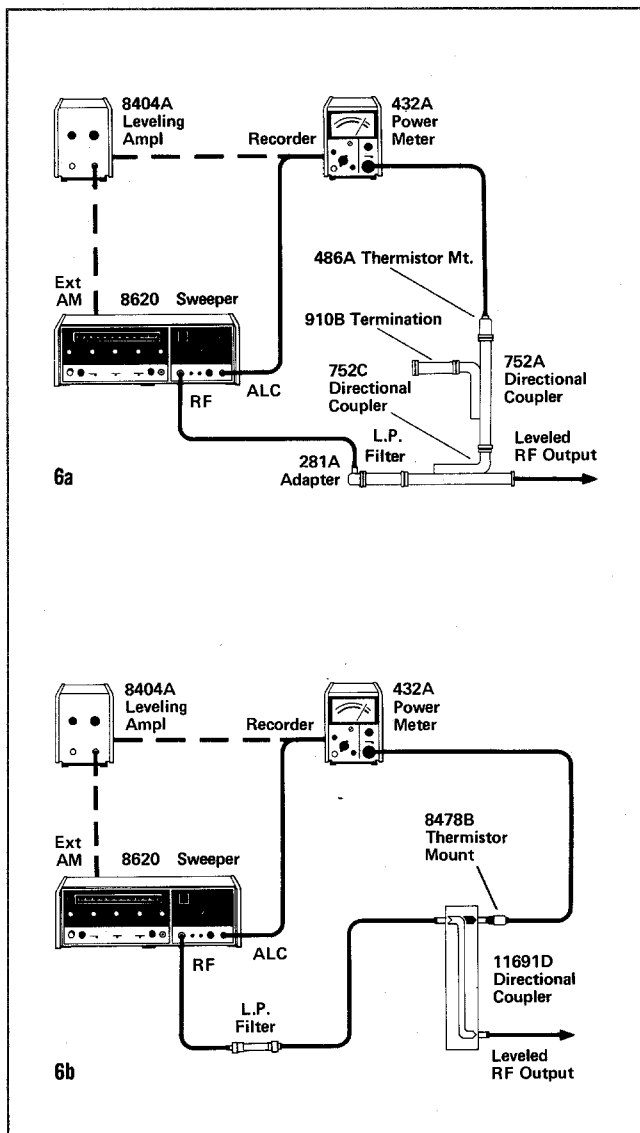


Figure 6. General systems for a) power meter super-leveling in waveguide (2.6 to 40 GHz) and b) power meter leveling in coax (0.1 to 18 GHz). Temperature compensated thermistor detectors have excellent frequency response resulting in flat leveled output. However, the thermistor's long thermal time constant necessitates longer sweep times (20 to 30 sec/octave) than the point-contact diode.

The basic procedure for power meter leveling is:

1. Set up the equipment as shown and zero HP 432 Series power meter. This establishes zero carry-over.

2. Set sweeper to START-STOP and MANUAL sweep. Set ALC to MTR and turn POWER LEVEL and ALC GAIN to maximum (clockwise).
3. An oscilloscope, preferably variable persistence, is useful to monitor for oscillations.
4. Manually sweep the frequency range of interest and locate the minimum power point with the meter. Adjust meter range so that the minimum power point is on the upper  $\frac{2}{3}$  of the meter scale.
5. Decrease POWER LEVEL until deflection occurs from the minimum power level. This is effectively leveling to the lowest power point of the unlevelled sweeper.
6. Manually sweep the band of interest allowing time for the thermistor to respond. If oscillations appear on the oscilloscope, remove them by decreasing ALC GAIN. This results in maximum leveled power. If another power meter is available the output can be monitored directly.
7. The power meter RANGE may be used for calibrated attenuation; i.e. a 5-dB decrease in the RANGE switch will produce a 5-dB decrease in leveled sweeper output.
8. Continuously variable leveled power below the maximum leveled power is available by moving the meter to a more sensitive range and adjusting the POWER LEVEL.

An HP 8404A leveling amplifier may be used to increase the gain of a power meter leveling loop, removing fine-grain variations in sweeper output power. If it is desirable to use an amplifier or the sweeper ALC switch does not have a MTR position, add the 8404A to the feedback loop and change the loop input to the sweeper from EXT INPUT to EXT AM; also adjust the POWER LEVEL and GAIN on the 8404A to a maximum. Then, follow the same procedure as used for basic power-meter leveling, using the 8404A POWER LEVEL and GAIN. Note, the UNLEVELED light does not indicate leveled power when leveling with an amplifier. The meter or oscilloscope must be used to determine the leveled condition.

#### LEVELING AFTER AN AMPLIFIER

Most sweepers have adequate leveled power for the majority of swept-measurement applications. However, some networks may require large stimulating signals in order to recreate normal operating conditions. In this situation, it is desirable to amplify the sweeper output and then level, compensating for any frequency variations in amplifier gain. A sweeper and TWT amplifier capable of producing one watt of leveled power are shown in Figure 7.

Leveling after an amplifier is very similar to leveling any other sweeper with a diode detector except that care must be taken not to saturate the amplifier. Saturation occurs when there is excess power at the amplifier input and an increase in input power results in no increase in output power.

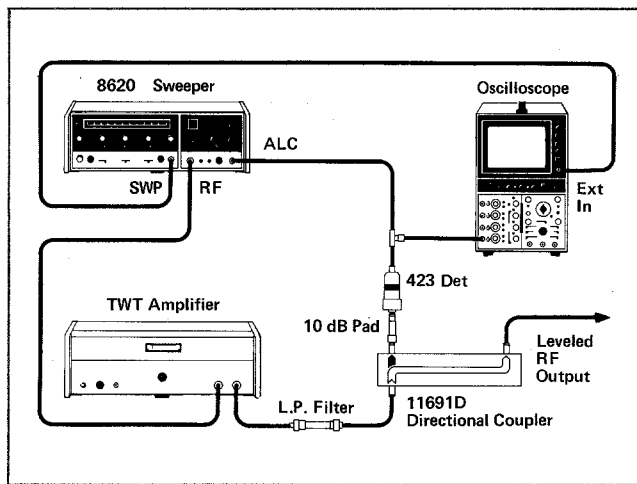


Figure 7. System for leveling sweeper output after amplification. The configuration consisting of the HP 8620 Series sweeper and HP 489-495 Series TWT amplifier (shown above) is capable of producing one watt of leveled power in the 1 to 12.4 GHz frequency bands.

Brief instruction for leveling after an amplifier are:

1. Set the sweeper up for a rapid START-STOP sweep over the frequencies of interest. Set ALC to EXT and turn POWER LEVEL and ALC GAIN to maximum.
2. Set TWT GAIN to RATED POWER using the CATHODE CURRENT meter, and properly terminate the output.
3. While observing the oscilloscope, decrease POWER LEVEL until a reduction in sweeper power results in a reduction in amplifier output power. If a reduction in sweeper power results in an increase in amplifier output power, the TWT is saturated and the input power must be further reduced.
4. After removing the amplifier from saturation, the situation is essentially that of any other diode leveling configuration; i.e. use sweeper POWER LEVEL and ALC GAIN to obtain maximum leveled power. Also, care should be taken not to saturate the detector.

The system in Figure 7 can be duplicated in waveguide by substituting the appropriate components.

#### LEVELING EFFECTIVENESS

Leveling effectiveness of the sweeper illustrated in Figures 4, 5, and 6 is dependent on several factors which have varying degrees of significance depending on the measurement situation. Where separate coupler and detector are used, sweeper leveling performance is dependent on the coupling variation, detector frequency response, ALC amplifier gain, and coupler-detector mismatch. If a directional detector is used, performance is dependent on frequency response of the directional detector and ALC amplifier gain. Sweeper harmonics will also affect leveling effectiveness if the appropriate low-pass filters (or bandpass filters) are omitted from the leveling loop.

At microwave frequencies, the leveling set-ups in Figures 4 (a) and 4 (b) generally have flatness of  $<\pm 1$  dB with coupling variation and detector frequency response as the major problems. Above 12.4 GHz the frequency response of the point-contact diodes becomes the major limitation. As subsequent measurement set-ups will demonstrate, coupling variation and detector frequency response are often compensated by tracking between the leveling coupler and detector and a complementary coupler and detector at another point in the measurement.

Improved flatness of  $<\pm 0.6$  dB and  $<\pm 0.4$  dB is typical when using the configurations in Figures 5 (a) and 5 (b) respectively. However, these setups are also limited above 12.4 GHz by the frequency response of point-contact diodes. Further, super leveling and directional detector leveling destroy complementary tracking relationship between the leveling coupler and another coupler in the measurement.

Power meter leveling, Figures 6 (a) and 6 (b), offers flatness of  $<\pm 0.5$  dB over most of the microwave frequency range. Since thermistor detectors do not have degraded frequency response characteristics above 12.4 GHz, leveling flatness of  $<\pm 0.8$  dB at 40 GHz is possible. The major limitation in power-meter leveling is the long sweep times required for operation of the thermistor detector.

A two-resistor power splitter, such as the HP 11667A may be substituted for a coax directional coupler in any of the externally leveled configurations below 18 GHz. The two-resistor power splitter has excellent tracking response ( $<0.2$  dB), especially in comparison to typical coupling variations ( $\pm 1$  dB). Flatness of  $\pm 0.5$  dB is typical for leveling with a power splitter and point-contact diode. However, power splitters have a 6-dB loss in each arm, resulting in a 6-dB reduction in leveled power output. Comparatively, the main arm losses of 10 dB and 20 dB directional couplers are 0.46 dB and 0.04 dB respectively.

### Frequency Stability

While sweepers generally have adequate frequency stability for most swept measurements, testing of some narrowband networks may require a more stable signal source. To make these measurements, sweeper output may be phase-locked to a harmonic of a stable low-frequency signal source. When phase-locked, the sweeper stability approaches that of the low-frequency source, but operation is limited to CW mode only.

### DETECTORS

Broadband swept measurements require accurate detection of both absolute and relative power levels over wide frequency ranges. In most swept measurements, detection for leveling and display of data is accomplished either by diode detectors or temperature-compensated thermal detectors.

There are five fundamental detector characteristics:

1. frequency response
2. reflection coefficient over full band
3. sensitivity
4. transfer characteristic
5. response time.

### Diode Detectors

Because of their nonlinear characteristics, diodes are commonly used in a wide variety of electronic devices as rectifiers and demodulators. Specifically, a diode provides a dc output when an unmodulated RF signal is applied or a low frequency ac output up to the tens of megahertz when the applied RF is modulated. They are widely used in swept microwave measurements because of their simplicity, sensitivity, fast response time, and broad frequency range.

A diode exhibits a square-law transfer characteristic when the output voltage variation is directly proportional to applied RF power variation. The square-law region and part of the linear region of a typical diode transfer characteristic is illustrated in Figure 8. Square-law response is important because it limits the dynamic range in some measurement techniques.

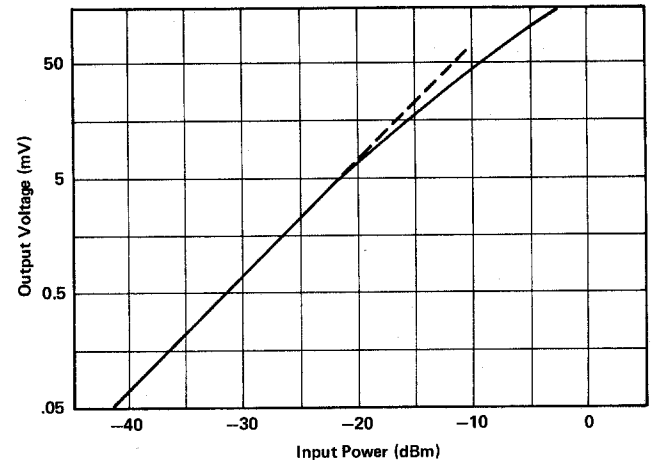


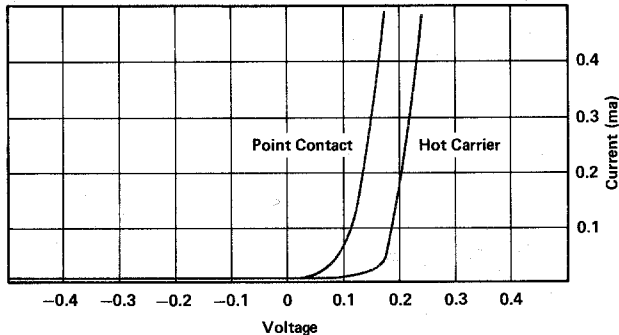
Figure 8. Typical point-contact diode transfer characteristic (incident RF power vs. output voltage). The diode exhibits a square-law transfer characteristic (incident RF power directly proportional to output voltage) for input power levels less than  $-20$  dBm.

### POINT-CONTACT VS. HOT-CARRIER (SCHOTTKY) DIODES

The two most commonly used diodes in swept measurements are the point-contact (crystal) and the hot-carrier. Point-contact diodes derive their name from the metal whisker that is inserted into a semiconductor chip during manufacture. Hot-carrier diodes have a similar Schottky (metal-semiconductor) junction; however, the process involves new techniques for metallization and is far more controllable than point-contact diode manufacturing processes. As a result, hot-carrier diodes are more rugged and exhibit excellent uniformity in their transfer characteristics. This allows the design

of standardized instrumentation to compensate for the non-square-law portion of the hot-carrier diode's transfer characteristic, resulting in an effective 60 dB of dynamic range.

Hot-carrier diodes also exhibit a more pronounced non-linearity (see the V-I curve in Figure 9) than point-contact diodes, resulting in higher sensitivity (-50 dBm vs. -45 dBm). However, increased sensitivity is normally achieved by dc biasing the hot-carrier diode for operation at the point of maximum non-linearity on the V-I curve. If biasing is employed, the applied RF signal must be modulated because low dc levels from small RF signals could not be detected in the presence of the bias.



**Figure 9.** Voltage-Current (V-I) Characteristics for point-contact and hot-carrier diodes. The hot-carrier diode exhibits a greater nonlinearity, hence greater sensitivity.

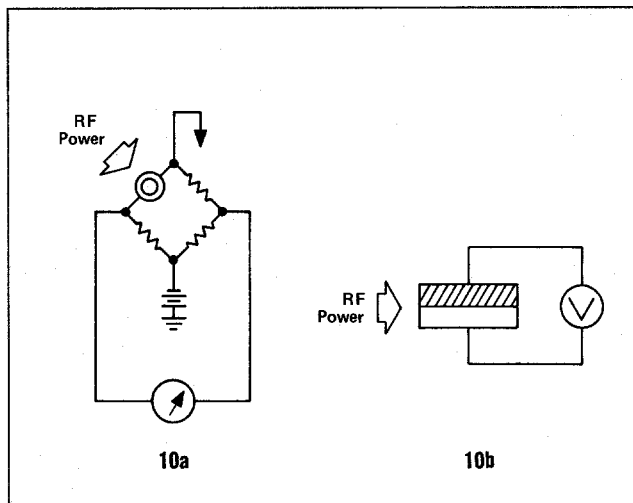
Point-contact diodes like the HP 420 Series operate at frequencies between 100 kHz and 40 GHz, while HP 11664A hot-carrier diodes operate over the 15-MHz to 18-GHz frequency range. Both devices are subject to burnout power levels  $>+20$  dBm.

### Thermal Detectors

Where accurate knowledge of average absolute power is required, temperature compensated thermal detectors such as bolometers and thermocouples are utilized. As their name implies, thermal detectors sense RF power levels by determining the amount of thermal energy or heat generated in a particular load impedance.

Bolometer detection is based on the fact that a thermal element's resistance changes with the RF power dissipated by the element. When such a thermal element is inserted into a bridge as in Figure 10 (a), absolute power can be measured through bridge balancing techniques using a differential amplifier. Bolometers are divided into two categories, barretters (positive-temperature coefficient) and thermistors (negative-temperature coefficient); a negative-temperature coefficient implies that increasing the RF power dissipated in an element results in a decrease in the element's resistance. Thermistors are by far the most common bolometer because they are more rugged and less subject to burnout than barretters.

Thermocouples [see Figure 10 (b)] operate on the principle that a dc voltage is generated when thermal energy is applied to a junction formed by two dissim-



**Figure 10.** Simplified diagrams for a) bolometer (thermistor or barretter) and b) thermocouple. A bolometer is a temperature-sensitive resistor facilitating power measurement through bridge balancing techniques. A thermocouple is a metallic junction of two dissimilar metals, generating a dc voltage when heat (incident RF signal) is applied.

ilar metals. The magnitude of the dc voltage developed across the junction is proportional to the thermal energy generated by the applied RF.

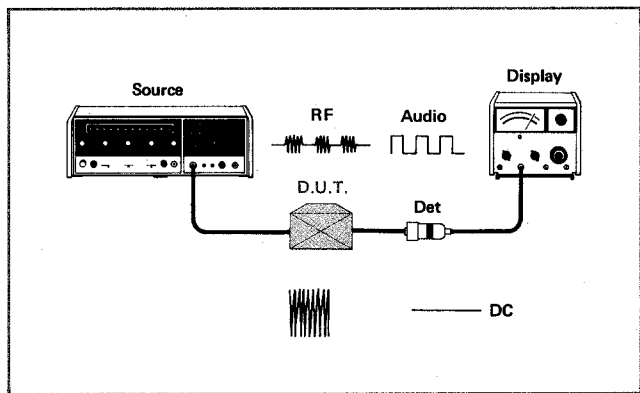
Thermistors are characterized by their broad frequency range (typically 1 MHz to 40 GHz), measurement range ( $1 \mu\text{W}$  to 10 mW), and low-frequency response. Similarly, thermocouples are noted for their 100-kHz to 18-GHz frequency range, low drift, measurement range ( $0.3 \mu\text{W}$  to 100 mW), and exceptionally low reflection coefficient (1.28 SWR at 18 GHz). Both types of detectors have long response times in comparison to diode detectors. Also, specially matched pads are incorporated into thermocouple detector mounts, allowing power measurement up to 3 W.

### Measurement Techniques

Detector characteristics significantly affect the choice of a measurement technique as well as subsequent display instrumentation. Measuring any unknown parameter is always executed by comparison of the unknown quantity to a known quantity, which is taken as the standard. In other words, whenever a measurement is performed, some kind of substitution or comparison between an unknown and a known is made. There are three common measurement techniques, audio substitution, RF substitution, and IF substitution, used in swept measurements. The choice of a technique for a particular application is based on three criteria: dynamic range; accuracy; and cost.

## AUDIO SUBSTITUTION/SQUARE-LAW DETECTION

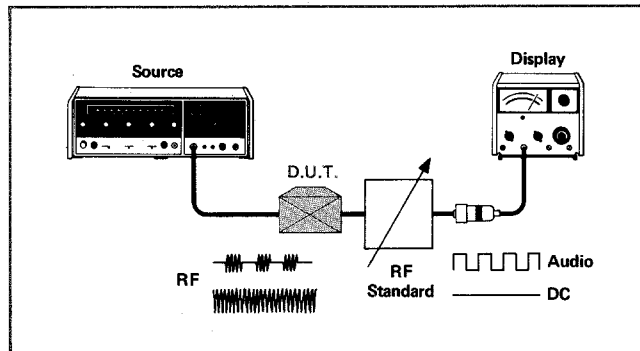
As Figure 11 indicates, audio substitution involves modulation of the RF source at an audio frequency. The diode detector detects or demodulates the RF providing an audio-frequency voltage output. As long as the detector is in square-law, the amplitude of its voltage output is directly proportional to the incident power. The change in output amplitude produced by inserting the Device Under Test is compared to a reference amplitude by substituting known calibrated audio gain or attenuation. The major advantages of audio substitution techniques are economy and simplicity. However, the dynamic range of the measurement is limited to the square-law region of the detector unless linearity compensation is employed.



**Figure 11.** Simplified Audio-Substitution measurement. The sweeper is amplitude modulated at an audio frequency. The detector detects or demodulates the RF signal, allowing precise substitution of audio frequency gain or attenuation in the display unit.

## RF SUBSTITUTION

In an RF-substitution measurement, a precision RF attenuator is utilized in the measurement and placed between the DUT and the detector. Otherwise, the measurement mechanics are essentially the same as the audio-substitution measurement; a measured amplitude is compared to a calibration amplitude by varying the RF attenuator.

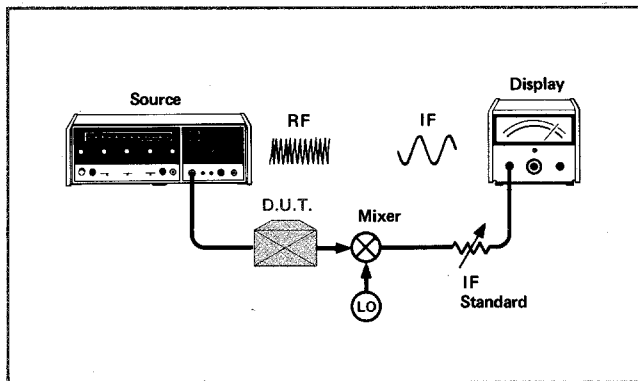


**Figure 12.** Simplified RF-Substitution measurement. Measurement is accomplished by comparison of the DUT to a precision RF attenuator, and the detector is not required to exhibit a square-law transfer characteristic.

The primary advantage of RF substitution is that it does not rely on square-law performance of the detector, since the detector is held at a constant signal level both in calibration and in measurement. The accuracy of the measurement is heavily dependent on the accuracy of the standard over the frequency range of interest. While much of the simplicity of audio substitution is maintained, precision RF attenuators usually cover narrow-bandwidths, necessitating several expensive attenuators to make multi-octave measurements.

## IF SUBSTITUTION/FREQUENCY CONVERSION

In Figure 13, the local oscillator (LO) is tuned to mix with the RF to produce a constant IF with the same amplitude information as the incoming RF signal. The measurement is made by comparing the measured amplitude to the calibration amplitude using an IF standard.



**Figure 13.** Simplified IF-Substitution measurement. The RF is mixed with a signal from a local oscillator to produce a constant IF (intermediate frequency) signal. Convenient IF filtering provides best sensitivity and selectivity of all techniques.

The narrow-bandwidth, single-frequency detection of the IF allows high sensitivity and dynamic ranges greater than 60 dB. Frequency conversion is expensive relative to audio and RF substitution and is usually employed in precision calibration instruments, spectrum analyzers, or multi-channel, phase-measuring network analyzers. More detailed discussions of IF substitution/frequency conversion are available in HP Application Notes 117-1 and 121-1.

## BROADBAND AND NARROWBAND DETECTION

The full-frequency spectrum of input signals is simultaneously accepted by broadband detection systems. Diodes, temperature-compensated thermistors and thermocouples are typical examples of broadband detectors. While generally economical, broadband systems usually sacrifice noise and harmonic rejection. However, harmonics can be eliminated through the careful use of filters.

Narrowband detection systems employ frequency conversion to transform the swept RF to a constant IF. This eliminates problems due to harmonics and facilitates high sensitivity through the low-noise detection of the IF. However, narrowband systems are generally less economical than broadband systems.

## DISPLAYS

Much of the convenience of swept measurements is dependent on continuous, real-time displays for readout of data. The basic technical features of a swept-measurement display system are:

1. Broad dynamic range for the measurement of large variations in input signal level is facilitated by a calibrated log display and detector linearity compensation.
2. Several detector inputs and processing channels are necessary for executing simultaneous measurements of the user's choice.
3. Ratio measurement capability, or the capability of comparing two detected signals, is required to minimize source mismatch errors without a leveled source.

4. Calibrated absolute-power measurement is necessary to assure optimum power for both the device under test and the measurement system.
5. Straightforward operating functions and controls provide efficient operation in a variety of measurement modes.

## HP 8755

The HP 8755 Frequency Response Test Set and some of its basic operating features are shown in Figure 14. It employs hot-carrier diode detectors and provides the appropriate linearity compensation for 60 dB of dynamic range over its 15-MHz to 18-GHz operating band.

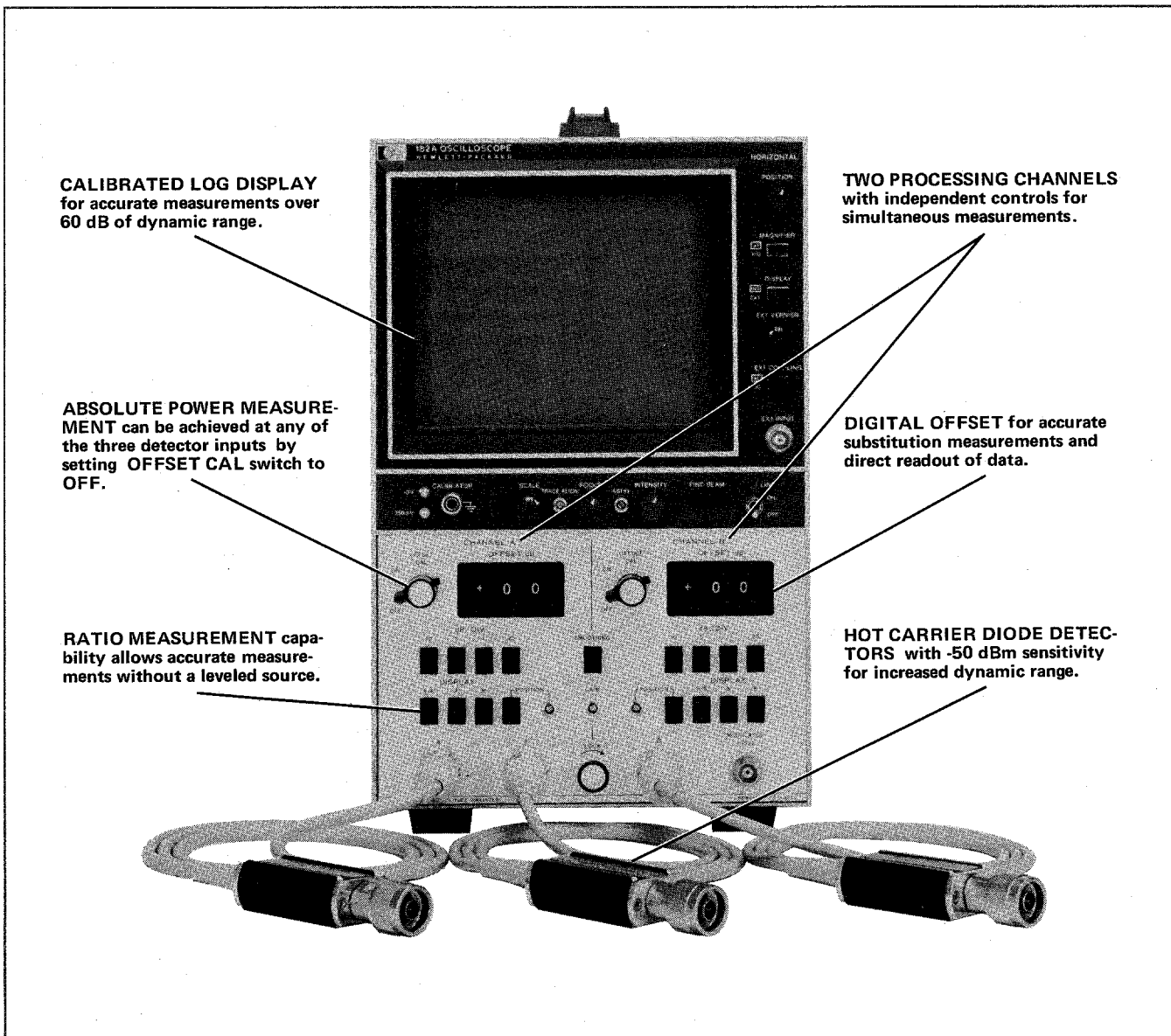
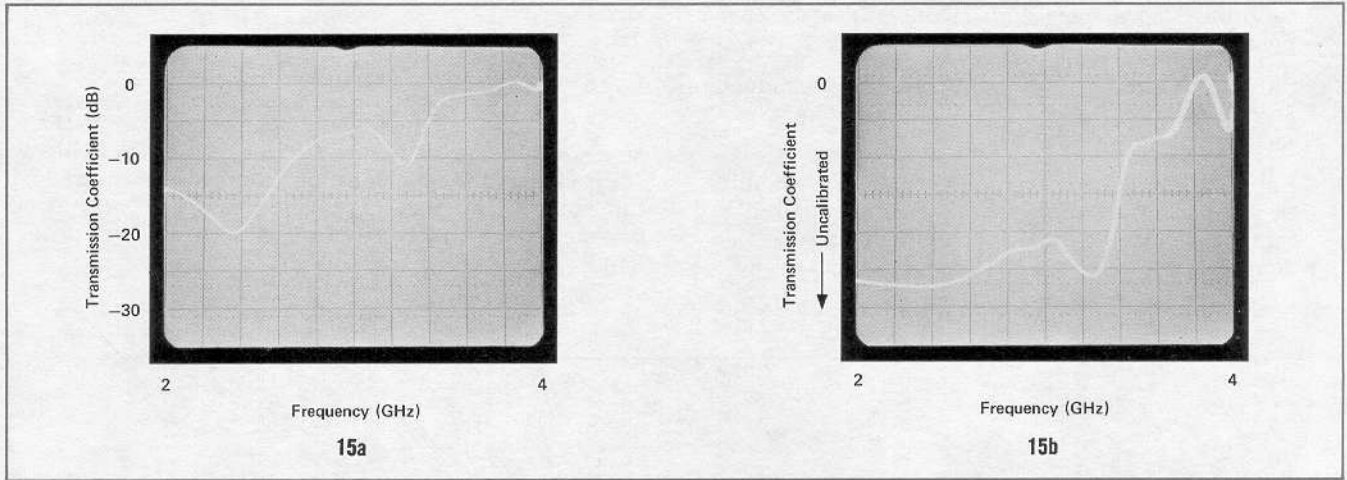


Figure 14. HP 8755 Frequency Response Test Set. Operation with hot-carrier diode detectors provides 60 dB of measurement range (+10 to -50 dBm) from 15 MHz to 18 GHz. The system also comes complete with an external modulator.

The differences between a linear oscilloscope display fed by a point-contact diode and a calibrated log display may be noted by observing the transmission loss through a high pass filter in Figures 15 (a) (log display) and 15 (b) (linear oscilloscope display). The uncalibrated linear display completely misses the 25-dB dip occurring at 2.4 GHz. While adequately defined, the

significance of the 11-dB dip near 3.3 GHz with respect to the passband ripple (3.8 to 4.0 GHz) is difficult to assess. This occurs primarily because the linear display over-responds to the passband ripple; an equivalent display of passband ripple without the confusion of rejection band characteristics may be obtained by increasing the log display's resolution.

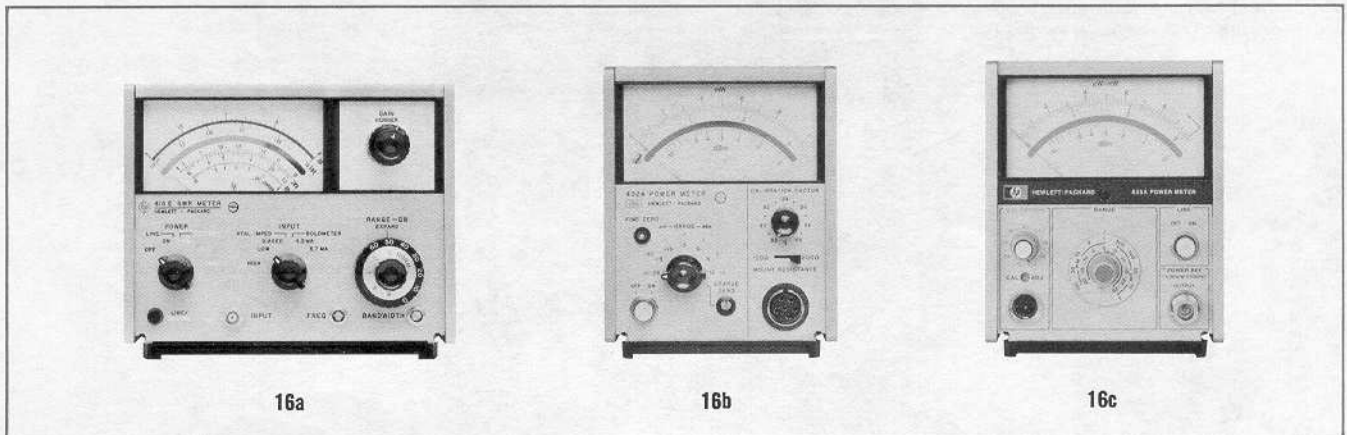


**Figure 15.** Transmission loss through a high-pass filter as displayed on a) calibrated log display (8755 system) and b) uncalibrated linear display (oscilloscope fed by a point-contact diode). Note that the linear display misses certain variations in the transmission characteristic, such as the 20-dB dip at 2.3 GHz, while over-accents the passband ripple (3.6 to 4 GHz).

### HP 415E

The 415E is a low-noise tuned amplifier-voltmeter calibrated in dB and SWR for use with square-law detectors in audio-substitution measurements. It may be used for measuring SWR, attenuation, gain or other parameters determined by the ratio of two signal levels.

The standard tuned frequency is 1000 Hz. The 415E also contains a precision 60-dB attenuator for attenuation or gain measurements with audio substitution. In swept measurements, the 415E's dc output is used to drive the X-Y recorder.



**Figure 16.** a) HP 415E SWR Meter, b) HP 432A Power Meter, and c) HP 435A Power Meter.

### HP 432 Series and HP 435A

The 432 Series Power Meters are designed to operate with thermistor detector mounts (HP 478A, HP 8478B, and HP 486 Series); the 435A Power Meter operates with the HP 8480 Series thermocouple detectors. The 432 Series indicates absolute power on full scale

ranges between 10  $\mu$ W and 10 mW while the 435A has full scale ranges between 3  $\mu$ W and 3 W. Both meters are fully calibrated to the appropriate detectors and offer readout accuracies of  $\pm 1\%$  of full scale. DC recorder outputs are available for making swept measurements with X-Y recorders.

## SIGNAL SEPARATION

The three most commonly used devices for signal separation in high-frequency swept measurements are:

1. directional coupler
2. directional bridge
3. power splitter.

Directional couplers are devices used to separate or sample the traveling wave moving in one direction on a transmission line while remaining virtually unaffected by the traveling wave moving in the opposite direction. Directional bridges have similar characteristics to directional couplers with a different internal implementation. Power splitters separate a traveling wave on a transmission line into two equal components.

Coupling factor, directivity, mainline loss, and mainline SWR are the four principal parameters defining directional coupler performance. Coupling factor is the fraction (in dB) of the power moving in the forward direction through the coupler main arm that appears at the secondary arm. Mathematically [see Figure 17 (a)]:

$$\text{Coupling factor} = -10 \log \frac{P_{2F}}{P_1} \quad (1)$$

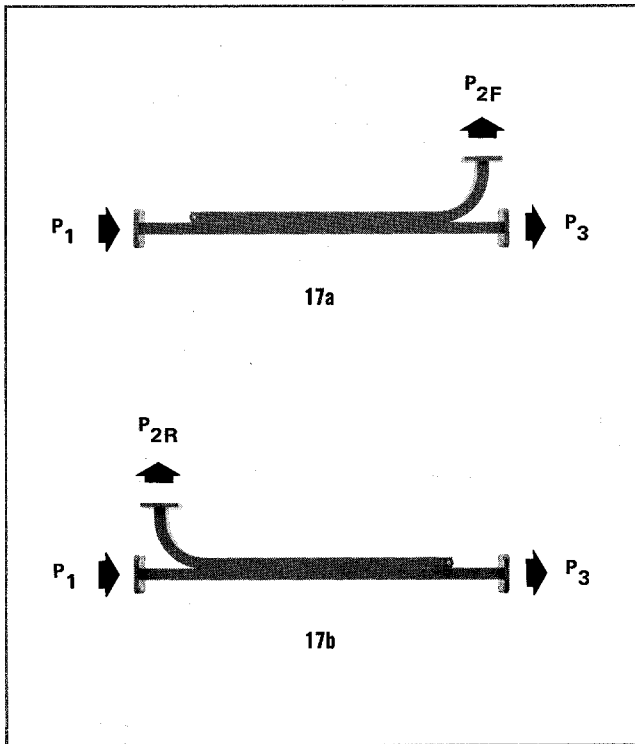


Figure 17. HP 752 Series precision multihole waveguide directional couplers with a) all power moving in the forward direction through the coupler and b) an equal power moving in the reverse direction.

$$\text{Coupling factor} = -10 \log \frac{P_{2F}}{P_1}, \text{ directivity} = -10 \log \frac{P_{2R}}{P_{2F}},$$

$$\text{and mainline loss} = -10 \log \frac{P_3}{P_1}.$$

Since directional couplers are not perfectly directional devices, directivity is used as a figure of merit for a coupler's ability to separate the forward and reverse traveling waves. Directivity is the ratio (in dB) of the power in the secondary arm when all the power is flowing in the forward direction of the main arm to the power in the secondary arm when an equal power is flowing in the reverse direction of the main arm. Mathematically [see Figure 17 (b)]:

$$\text{Directivity} = -10 \log \frac{P_{2R}}{P_{2F}}.$$

The mainline loss is the fraction of power lost by a traveling wave moving in either direction through the main arm of a directional coupler. Mathematically [see Figure 17 (a) and 17 (b)]:

$$\text{Mainline loss} = -10 \log \frac{P_3}{P_1}.$$

Mainline SWR is a measure of mismatch at the coupler output port and is important in qualifying effective source match. An HP 11692D (2 to 18 GHz) dual coax directional coupler for independently sampling both the forward and reverse traveling waves is shown in Figure 18 (a).

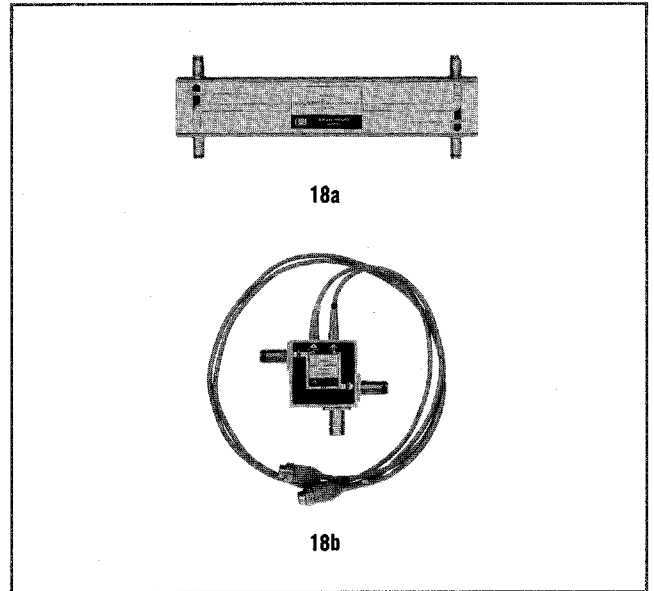


Figure 18. a) HP 11692D, 2 to 18 GHz high directivity, coax dual-directional coupler and b) HP 11666A 40 MHz to 18 GHz coax reflectometer bridge.

Directional bridges utilize impedance bridge techniques to accomplish the same objectives as directional couplers. Main arm to auxiliary arm coupling, directivity, and mainline SWR are the important parameters in qualifying directional bridges. Main arm to auxiliary arm coupling is equivalent to the sum of the mainline loss and coupling factor in a directional coupler. The HP 11666A Reflectometer Bridge shown in Figure 18 (b) may be used in swept measurements between 40 MHz and 18 GHz to sample both forward and reverse traveling waves. The forward wave and the reverse wave are sampled by a directional bridge, and two hot-carrier diode detectors are built in for use with the 8755 Frequency Response Test Set.

Power splitters are usually defined by their main arm insertion loss, equivalent output SWR, and output tracking. Main arm insertion loss is the loss that occurs between the input and either of the two output arms (see Figure 19):

$$\text{Main arm loss} = -10 \log \frac{P_{\text{out1}}}{P_{\text{in}}} = -10 \log \frac{P_{\text{out2}}}{P_{\text{in}}}$$

Output tracking (in dB) indicates how well the splitter maintains equality between  $P_{\text{out1}}$  and  $P_{\text{out2}}$  (see Figure 19):

$$\text{Output tracking} = 10 \log \frac{P_{\text{out1}}}{P_{\text{out2}}}$$

Equivalent output SWR is a measure of how good a source match may be obtained when a power splitter is used in leveling a sweeper or in a ratio measurement. Power splitters may be of either two-resistor or three-resistor construction; three-resistor power splitters are greatly inferior to two-resistor power splitters in terms of equivalent output SWR when used in leveling or ratio applications (see Appendix A).

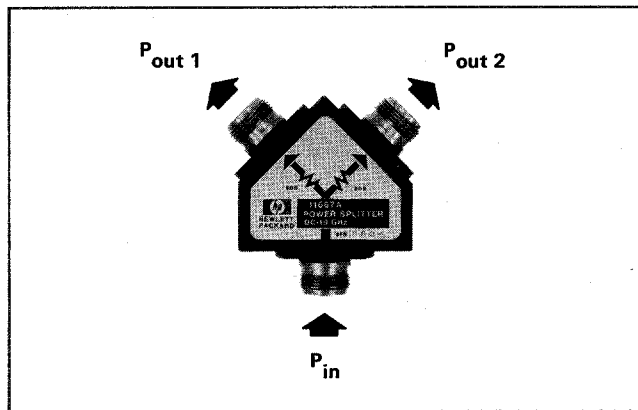


Figure 19. HP 11667A dc to 18 GHz two-resistor power splitter. Main arm loss =  $-10 \log \frac{P_{\text{out1}}}{P_{\text{in}}} = 6 \text{ dB}$  and main arm tracking =  $10 \log \frac{P_{\text{out1}}}{P_{\text{out2}}}$  (typically  $< 0.2 \text{ dB}$ ). Two-resistor power splitters exhibit excellent equivalent output SWR (typically 1.2 SWR) when used in leveling sweepers or ratio measurements.

# IMPEDANCE

Characterization of impedance as a function of frequency is fundamental to both the design and test of broadband high frequency networks. However, the wavelengths of high-frequency signals are usually small compared to the physical size of the networks under test, necessitating the application of transmission-line theory in obtaining impedance data.

According to transmission-line theory, a signal applied to a uniform, lossless line terminated in an impedance different from its characteristic impedance will produce both an incident and a reflected traveling wave. These two traveling waves add to form a stationary standing wave along the transmission line. The terminating impedance is proportional to the magnitude of the reflected wave and the amplitude variation in the standing wave, resulting in two basic, but related, high-frequency impedance expressions. Quantitatively, these relationships are explained in terms of reflection coefficient and standing-wave ratio. Equations 1 through 4 present the common expressions for impedance both in linear and log form.

$$\text{Reflection Coefficient Magnitude: } \rho = \left| \frac{E_{\text{reflected}}}{E_{\text{incident}}} \right| \quad (1)$$

$$\text{Return Loss (dB): } \text{RL (dB)} = -20 \log \rho \quad (2)$$

$$\text{Standing Wave Ratio: } \text{SWR} = \left| \frac{E_{\text{max}}}{E_{\text{min}}} \right| = \frac{1 + \rho}{1 - \rho} \quad (3)$$

$$\text{Standing Wave Ratio (dB): } \text{SWR (dB)} = 20 \log \text{SWR} \quad (4)$$

Swept-reflection coefficient or return loss is measured directly using a reflectometer measurement configuration. A reflectometer utilizes the ability of directional couplers or directional bridges to individually sample the incident and reflected traveling waves. Reflection coefficient or return loss is determined by performing the ratio of the detected signal levels. The ratio may be performed in either of two ways:

1. **DIRECT RATIOING:** In direct ratioing both incident and reflected signal samples are fed directly into an instrument like the 8755 system which performs the ratio.
2. **LEVELING:**  $|E_{\text{inc}}|$  is maintained at a constant level both in calibration and test by externally leveling the sweeper output.

In both cases the net effect is the same; however, direct ratio measurements are usually more convenient because the sweeper does not have to be leveled prior to making the measurement. The equivalence between ratioing and leveling is explained mathematically in Appendix A.

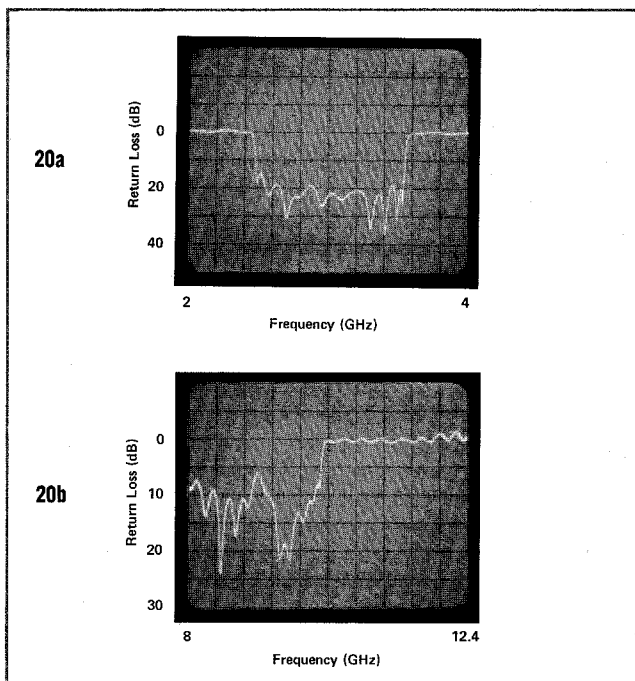
Swept standing-wave ratios are measured directly using a swept slotted line. A slotted line is a section of uniform transmission line with a longitudinal slot that allows insertion of a probing device. The probing device measures the electrical field strength along the transmission path of the slotted line, allowing determination of  $|E_{\text{max}}|$  and  $|E_{\text{min}}|$ , hence SWR. By simultaneously sweeping the frequency and moving the probe along the slotted-line path, SWR may be determined on a swept basis. The 8755A/181T Storage Oscilloscope display can then be used to display the result directly in SWR (dB).

Applications of the reflectometer or slotted line are generally determined on the basis of the convenience and the accuracy desired in a particular measurement. Return loss and SWR (dB) are directly related by equations 1 through 4, allowing the final measurement data to be converted to the desired format no matter which technique was used in the original measurement.

The objective of this section is to present the basic reflectometer and slotted-line impedance measurements. To this end, accuracy considerations and models will be discussed, as well as the relative applicability of both techniques.

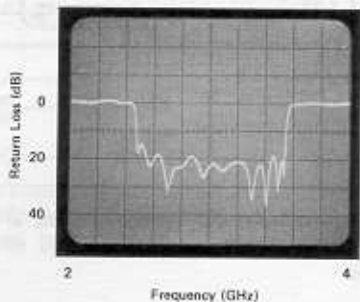
## COAX REFLECTOMETER MEASUREMENTS

Figure 20 exhibits the results of some typical return loss measurements in coax using the 8755 reflectometer systems of either Figure 21 (a) or 21 (b). Because of its speed and versatility, the reflectometer is



**Figure 20.** Return-loss measurements of a) bandpass filter and b) low-pass filter as seen on the display of the 8755 Frequency Response Test Set.

20a



20b

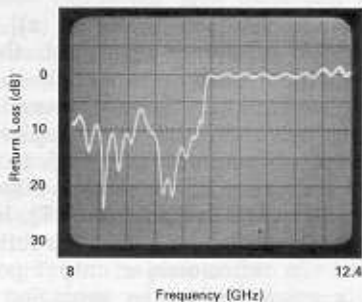


Figure 20. Return-loss measurements of a) bandpass filter and b) low-pass filter as seen on the display of the 8755 Frequency Response Test Set.

one of the most widely used systems for obtaining broadband swept-impedance data in coax. For instance, the reflectometers in Figures 21 (a) and 21 (b) are capable of return loss measurements from 15 MHz to 18 GHz, assuming the sweeper and directional couplers (or directional bridges) operate over the frequency range of interest.

Since the 8755 system has ratio measuring capabilities, the sweeper does not necessarily have to be leveled as it was in many older reflectometers. (See Appendix A for a discussion of leveling vs. ratioing.) In a leveled system the variations in the incident traveling wave are compensated for by the sweeper leveling loop. Ratio-measuring instruments similarly compensate for any variation in the incident traveling wave by instantaneously ratioing it with the reflected wave, and leveling is not required unless the DUT is input-power sensitive. Because setup and calibration are both quicker and easier, ratio measurements are generally preferred. However, internally leveled sweepers are convenient for controlling wide variations in input power to the DUT when making ratio measurements.

At this point, it should be re-emphasized that the 8755 system is a broadband detection system; therefore care must be taken to eliminate spurious and harmonic signals that might otherwise introduce errors into the measurement. Incorporation of a low-pass filter, like the one shown in Figure 21, is usually sufficient to eliminate errors caused by source harmonics. However, if the source produces sub-harmonics or other spurious signals, careful use of high-pass or bandpass filters may be required.

A general outline of the reflectometer measurement procedure is presented below.

### Set up and Calibration

1. Set up the equipment as shown in Figure 21 and adjust the sweeper to sweep the frequency range of interest.
2. Use the 8755A POSITION controls to adjust the 0 dB/0 dBm position line to a convenient graticule, hence referred to as the position graticule.
3. Remove the R detector and connect it to the measurement port. With the OFFSET CAL in the OFF position adjust the sweeper output for approximately +10 dBm at the measurement port (if <+10 dBm, adjust for maximum). By using the 8755 system's capability to measure absolute power (OFFSET CAL to OFF), maximum dynamic range is assured. Care should also be taken not to exceed input power specifications of the DUT.
4. Return R detector to its normal position and set 8755A for a ratio measurement (A/R).
5. Connect a short to the test port. With OFFSET dB at  $\pm 00$  and OFFSET CAL to ON, use the OFFSET CAL vernier to average any variation in the calibration trace about the position graticule.

Note: The 8755 reflectometer system is now calibrated for swept return loss measurements. If the OFFSET CAL vernier is moved during the measurement, calibration will be destroyed.

### Measurement

6. Remove the short and connect the DUT to the measurement port. Be careful to terminate the DUT in its characteristic impedance if it has two or more ports.

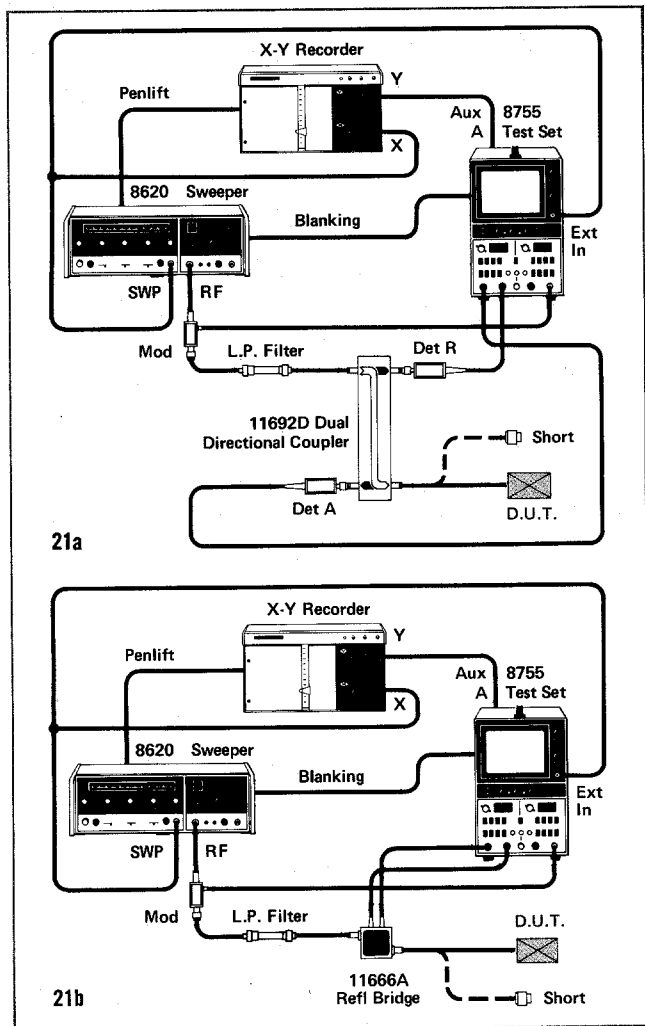
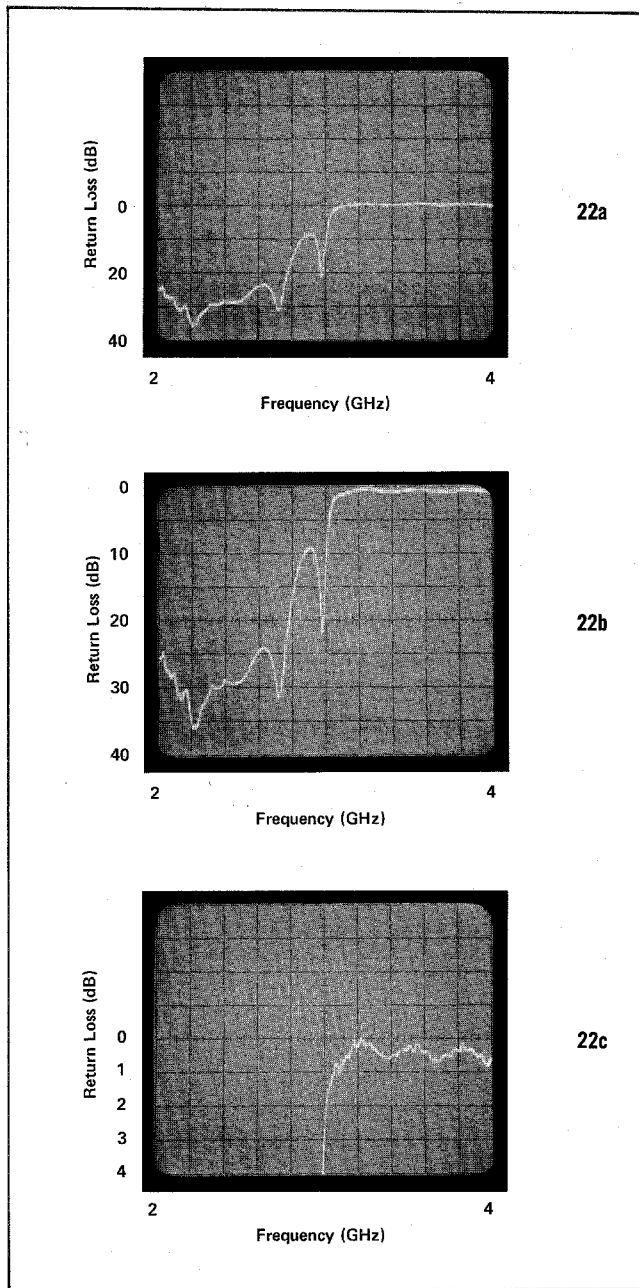


Figure 21. 8755 coax reflectometer systems utilizing a) 11692D 2 to 18 GHz dual directional coupler and b) 11666A 40 MHz to 18 GHz reflectometer bridge.

In the reflectometer [see Figure 21 (a)], the R detector of the 8755 system is placed on the forward arm of the directional coupler to sample the incident traveling wave while the A detector samples the reflected traveling wave through the coupler's reverse arm. The 8755 system automatically performs the ratio of the reflected and the incident signals, displaying the results in terms of swept return loss (dB). Initial calibration is achieved by placing a short circuit (R.L. = 0 dB or  $\rho = 1$ ) at the reflectometer output port. Actual measurement is accomplished by replacing the short with a DUT (device under test) and displaying the results on a CRT or X-Y recorder. Sweep speeds may be adjusted either for continuous CRT displays or slower X-Y recordings.

7. Use the OFFSET dB thumbwheels and RESOLUTION push-buttons to obtain a suitable display.
8. OFFSET dB thumbwheels can be used for accurate substitution measurements and digital readout of return loss (to the nearest dB) at any point on the trace. Once the thumbwheels have been used to bring the point of interest to the position graticule, resolution may be increased without the trace leaving the screen.

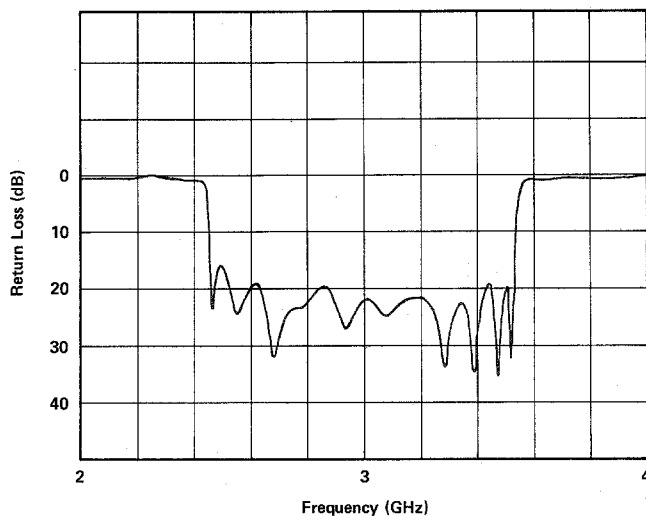
The advantages of increased resolution are demonstrated by the series of CRT photos in Figure 22. Using the appropriate offset, resolution may be increased for a better view of the trace as a whole or a particular area of interest.



**Figure 22.** Return loss of a low-pass filter at various levels of resolution, a) 10 dB/div, b) 5 dB/div, and c) 1 dB/div. Note that increased resolution can be used for a better display of the trace as a whole, (b), or close scrutiny of the rejection band return loss, (c).

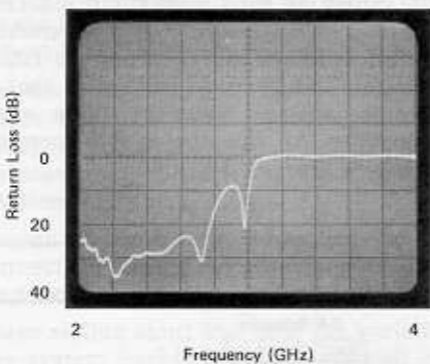
During calibration the absolute power at the measurement port was adjusted for approximately +10 dBm. Assuming a nominal coupling factor of 20 dB, +10 dB would allow 40 dB of dynamic range in a return loss measurement. However, this is not a restriction since high return loss measurements are normally limited by the directivity of the reverse directional coupler which is usually <40 dB.

If X-Y recordings of data are desired, they are easily secured by adding an X-Y recorder to the measurement setups in Figure 21. Since the 8755 system auxiliary outputs (AUX A and AUX B) provide 0.5 volts/scale division, a recording of any trace at any resolution may be obtained after the recorder has been initially calibrated. A typical X-Y recording is shown in Figure 23.

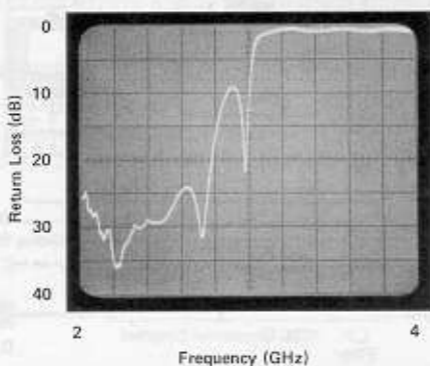


**Figure 23.** X-Y recording of a bandpass filter return loss. The recording was made with the 8755 reflectometer system in Figure 21 (a).

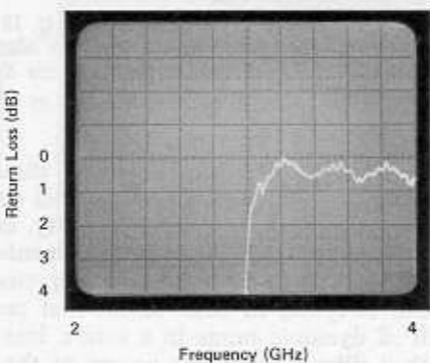
Because calibrated grid lines can be plotted and stored on an X-Y recorder, the recorder is particularly useful in making high-resolution return loss measurements. Variations in the calibrated grid lines are caused by tracking errors (frequency response) and calibration errors in the reflectometer system; however, the contribution of source match to effective system calibration errors varies with the phase of the load at the measurement port. Ideally, a calibration grid should be plotted with a short ( $\rho = 1$ ) and with an open ( $\rho = 1$ , but  $180^\circ$  different in phase from the short); the mean of these two grids would be taken as the actual calibration grid. This procedure is difficult to follow because open circuits have finite capacitance, causing the phase angle to differ from that of a perfect open ( $0^\circ$ ) at frequencies above 8 GHz.



22a



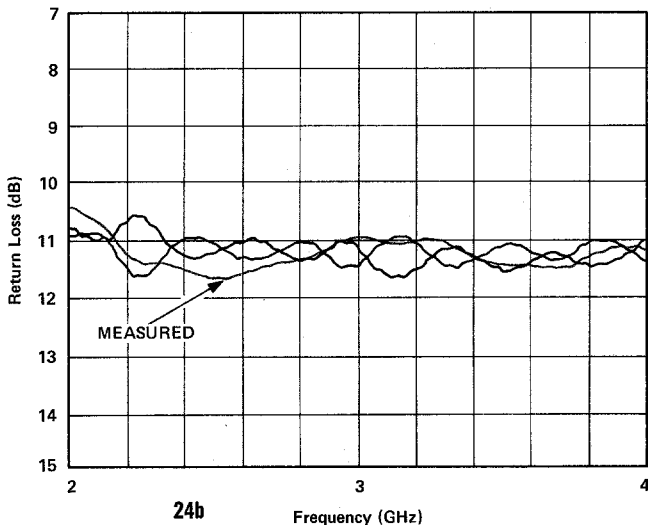
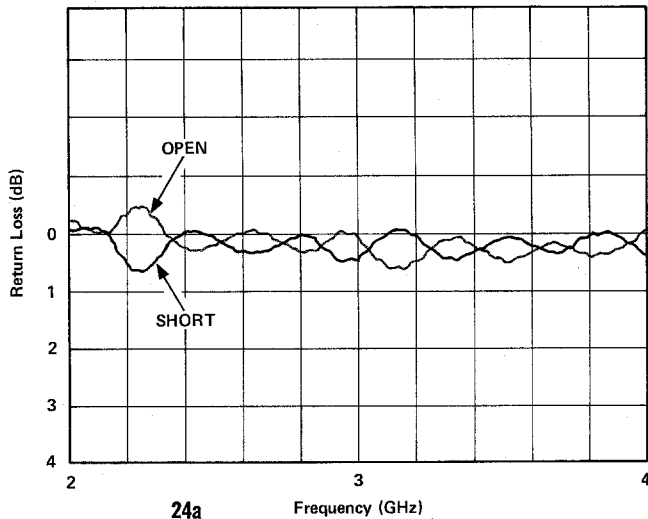
22b



22c

Figure 22. Return loss of a low-pass filter at various levels of resolution, a) 10 dB/div, b) 5 dB/div, and c) 1 dB/div. Note that increased resolution can be used for a better display of the trace as a whole, (b), or close scrutiny of the rejection band return loss, (c).

In Figure 24 the progressive steps are demonstrated for making a high-resolution X-Y recording of return loss data. The first grid is drawn with the measurement port shorted. Because the impedance resulting from the connector capacitances is small between 2 GHz and 4 GHz, the measurement port may be opened and a second calibration grid plotted. The mean of these two grids is assumed to be the true calibration grid. The DUT is then connected at the test port and the measurement consummated, resulting in the plot in Figure 24.



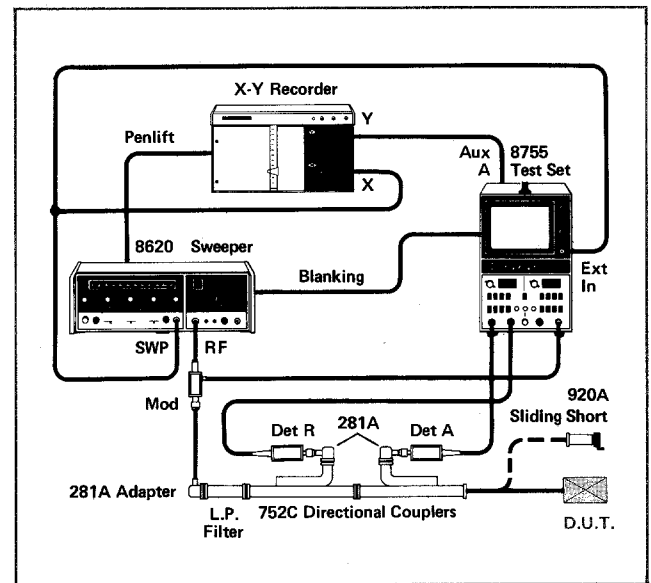
**Figure 24.** High resolution X-Y recording of return loss. Two calibration grids, one with the test port shorted and the other with it opened, are plotted in a), and the mean taken as the true grid. The DUT is inserted; the 8755 system adjusted to the correct Offset dB setting, and the high resolution measurement accomplished in b).

The open/short calibration improves measurement accuracies because it eliminates calibration and tracking (frequency response) errors from system uncertainty. In general, most coaxial connectors act as reasonable open circuits to 8 GHz. Complete elimination of source match and directivity errors is not possible without both phase and magnitude information.

An alternative means of storing the reflectometer tracking errors (frequency response) is to make a grease-pencil recording on the CRT of the calibration trace. As in the case of X-Y recordings, it is normally sufficient to record only the calibration trace resulting from a short at the reflectometer test port. When the actual measurement is executed the OFFSET dB thumbwheels can be used to compare the measurement trace to the grease-pencil recording. Of course, all measurements involving the grease-pencil recording must be made at the same resolution as the original recording.

## WAVEGUIDE REFLECTOMETER MEASUREMENTS

Figure 25 shows an 8755 waveguide reflectometer system for making swept return loss measurements in waveguide bands between 2.6 GHz and 18 GHz. The theory of operation is virtually identical to that of the coax reflectometer system. However, there are some differences peculiar to the waveguide components themselves that are discussed below.



**Figure 25.** 8755 waveguide reflectometer system (2.6 to 18 GHz in waveguide bands). Note HP 281 Series waveguide-to-coax adapters are required to connect the 11664A detectors to the waveguide directional couplers.

The precision multi-hole waveguide directional couplers utilized in Figure 25 have a nominal coupling coefficient of 10 dB and >40 dB of directivity. Because of the high directivity, return loss measurements up to 40 dB are feasible. The 10-dB mean coupling, compared to 20-dB mean coupling in coax directional couplers, allows 40 dB of dynamic range in a return loss measurement with 0 dBm of incident power at the measurement port. Note that waveguide-coax adapters are employed to attach the 11664A detectors to the waveguide couplers.

Another particularly distinctive feature of waveguide systems is the availability of high quality sliding

short. A waveguide sliding short has a constant reflection coefficient of unity ( $\rho = 1$  or R.L. = 0 dB) which can be phased through  $>180^\circ$ . Since an open circuit can be simulated at the measurement port by a short one-quarter wavelength removed, it is now possible to see the total effect of source match on effective system tracking errors. This is easily observed on the CRT by sliding the short at least one-quarter wavelength of the lowest frequency in band being swept.

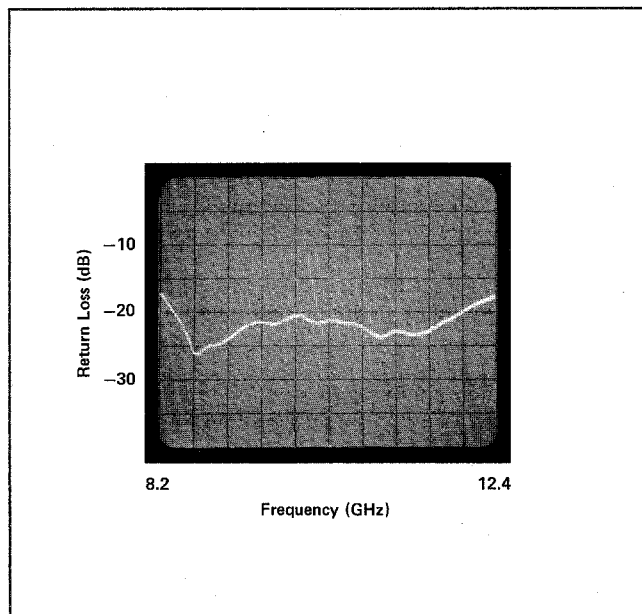
The measurement procedure for the waveguide reflectometer is similar to that of the coax reflectometer. The important points and major differences are outlined below.

### Set Up and Calibration

1. Set up the equipment as shown in Figure 25 and set the sweeper for the frequency range of interest. Adjust POSITION controls on 8755A if necessary.
2. Use the R detector and adapter to measure the absolute power at the measurement port. Adjust sweeper output power for 0 dBm to +10 dBm at the measurement port (assuming 10-dB directional couplers are used).
3. Reconnect the R detector to the forward coupler, connect the sliding short to test port, and set 8755A for ratio measurement (A/R).
4. Phase sliding short and note the variation in effective system tracking errors. Establish 0 dB return-loss calibration by averaging the variation in the tracking errors about the position graticule.

### Measurement

5. Same procedure as the coax reflectometer. Figure 26 shows the return loss of the X486A thermistor mount measured on the system in Figure 25.

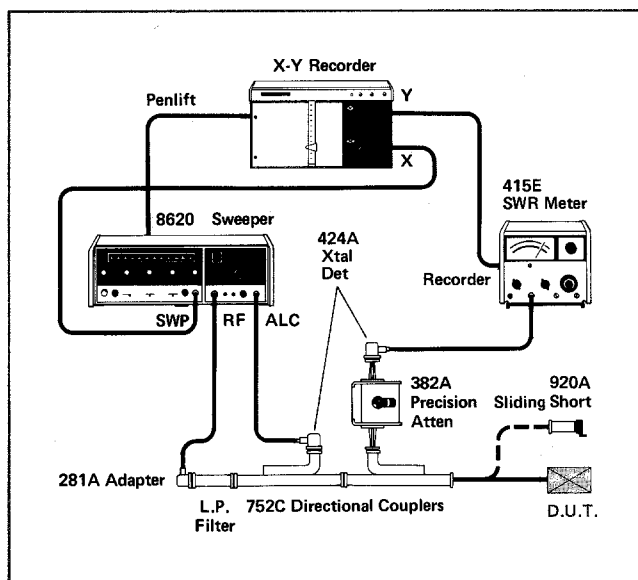


**Figure 26.** Return loss of an HP X486A thermistor mount. The maximum SWR specification for the X486A is 1.5 SWR (R.L. = 14 dB). Note that the thermistor mount tested above is generally much better than the specification over the full operating band.

X-Y recordings may be obtained by adding an X-Y recorder to the measurement setup in Figure 25 and proceeding in a fashion similar to that used for the coax reflectometer. The only major difference between the coax and waveguide systems is in the plotting of calibrated grid lines. When plotting the grids, the sliding short should be rapidly phased to simulate the various phases of load impedance. The result is a fine-grain variation in the grid lines which defines the limits of source match contribution to effective tracking errors. The mean of these variations is taken as the true calibrated grid. As in the case of coax reflectometers, plotting of calibrated grids can be ignored where high resolution is not required, and grease pencils can be used to record calibration traces directly on the CRT.

### WAVEGUIDE REFLECTOMETER MEASUREMENTS WITH RF SUBSTITUTION

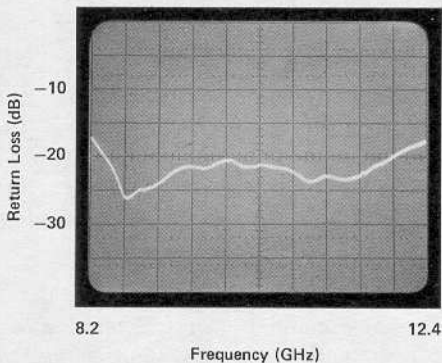
An RF-substitution technique for making swept reflectometer measurements from 2.6 GHz to 40 GHz is shown in Figure 27.<sup>2</sup> System operation is based on a leveled sweeper and a precision RF rotary-vane attenuator. Before the actual measurement is executed, specific values of return loss are pre-inserted via the attenuator, and the results stored in the form of calibration grids on the X-Y recorder. While RF substitution is not as convenient as the 8755 reflectometer, it does operate above 18 GHz and is composed of economical instruments.



**Figure 27.** System for measuring swept return loss using RF substitution techniques. With the test port shorted, values of return loss are pre-inserted using the precision attenuator and calibration grids plotted. The short is replaced by the DUT; the attenuator set to a reference value; and the measured trace compared to the calibration grids.

Obtaining maximum leveled power from the sweeper is the initial step in calibrating the system in Figure 27. The sweeper is essentially externally leveled in

<sup>2</sup> An 8690 Series sweeper must be used at frequencies above 18 GHz.



**Figure 26.** Return loss of an HP X486A thermistor mount. The maximum SWR specification for the X486A is 1.5 SWR (R.L. = 14 dB). Note that the thermistor mount tested above is generally much better than the specification over the full operating band.

waveguide with a point-contact diode. Since the sweeper output is leveled, forward (or incident) power must remain constant both as a function of frequency and load impedance. Thus, it can be assumed that incident power at the measurement port will be the same in both calibration and measurement. As noted in the discussions of 8755 reflectometer system, leveling accomplishes the same effect as ratioing (see Appendix A). Operation of the 415E SWR Meter requires the sweeper output to be amplitude modulated at a 1-kHz rate. 1-kHz amplitude modulation is available internally on all 8620 and 8690 sweepers.

With the reflectometer test port shorted, the 382 precision attenuator is used to pre-insert specific values of return loss in the reverse measurement arm. By manually triggering the sweeper for single sweeps, grid lines at each attenuator setting are sequentially plotted on the X-Y recorder. During each calibration sweep, the sliding short is rapidly phased so that all phases of the source match error signal will be encountered at the reverse arm detector. The result is a fine-grain variation in the grid lines which defines the limits of source match error contribution. As in the case of the 8755 reflectometer, the mean of these variations will be taken as the true value of return loss for each grid. Thus source match error is minimized, and better system accuracy is attained.

After the grid lines have been drawn, the short is removed and replaced with the DUT. A final sweep is triggered with the attenuator set to zero, and the return loss plotted on the X-Y recorder. The results of such a return loss measurement are shown in Figure 28.

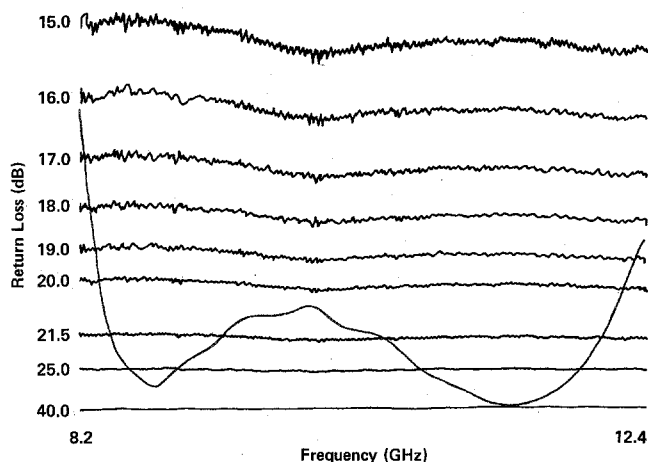


Figure 28. X-Y recording of the return loss of an HP X486A thermistor mount (similar to the one tested in Figure 26) using the RF-substitution system in Figure 27.

Once the calibrated grid lines have been drawn, they can be used as an underlay for many measurements with the actual return loss of the DUT recorded on translucent paper. However, grids should be redrawn after long hours of operation or after the equipment has been turned off.

In the setup in Figure 27, the 415E acts solely as an amplifier, amplifying the signal from the reverse arm detector. This allows the Y-axis of the X-Y recorder to

be driven at a higher signal level and errors from recorder noise avoided. In alternative measurement configurations, the 415E could be supplanted by a 432 Series or a 435A Power Meter, performing the same function. It is also possible to use an 8755 system in a RF-substitution measurement either as an amplifier or a ratio measuring device. In the latter case the sweeper leveling loop would be eliminated. If the 8755 is used, the basic measurement procedure remains unchanged, except that the 382A precision attenuator instead of the OFFSET dB thumbwheels is used for substitution purposes.

A full 40 dB of dynamic range in a return loss measurement is provided by the system in Figure 27. As in most reflectometers, the directivity of the directional couplers (>40 dB for HP 752C couplers) is the limiting factor of dynamic range. Further, the point-contact diodes are not constrained to operate with square-law response since the detector always operates at the same level both in calibration and measurement conditions.

## REFLECTOMETER ACCURACY

Sources of uncertainty in reflectometer measurement systems are generally classified as directivity, tracking, calibration, and effective source match errors. These four sources of error may be collected into a general error equation:

$$\Delta\rho = A + B\rho + C\rho^2. \quad (5)$$

The value of the A and C coefficients is determined by the directivity and source match errors respectively, while B is composed of frequency response, instrument, and calibration errors. A complete derivation of equation (5) and numerical examples are provided in Appendix B. It is important to remember that all three error terms are functions of frequency and will usually vary significantly over the frequency range of interest.

An HP Reflectometer Calculator<sup>3</sup> like the one in Figure 29 is useful both in changing the form of impedance data and in determining the measurement uncertainties caused by coupler directivity. For example, the calculator in Figure 29 is set for a reflection coefficient of 0.20, using the blue arrow above the top scale. The corresponding SWR of 1.5 and return loss of 14 dB are indicated by the blue arrows above and below the lower scales, avoiding the calculations required in equations (2) and (3). The Coupler Directivity (dB) graduations, signify the worst-case window of uncertainty caused by the directivity of the directional coupler. For instance, a coupler with 40 dB of directivity is used to measure a return loss of 14 dB, the actual value of return loss could be anywhere between 13.6 dB and 14.4 dB depending on the vectorial relationship between the directivity and reflected signal. For directivity of 26 dB, the actual return loss could be as low as 12 dB or as high as 16.6 dB. Similarly, the Coupler Directivity graduations also denote the worst-case values of SWR and  $\rho$ .

<sup>3</sup> A complimentary HP Reflectometer/Mismatch Error Limits Calculator is available from any Hewlett-Packard sales office.

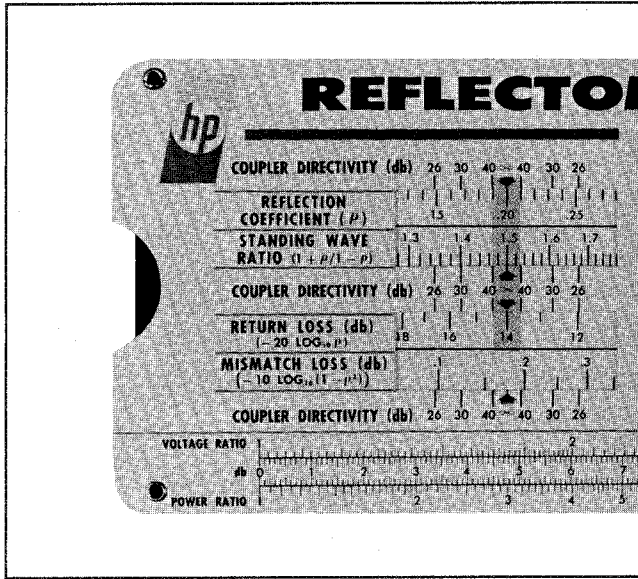


Figure 29. HP Reflectometer Calculators are used for conversions between  $\rho$  SWR, and Return Loss. Worst-case uncertainties caused by Coupler Directivity and Mismatch Loss for absolute power measurements may also be calculated. The calculator's present setting indicates that a  $\rho = 0.2$  is equivalent to a  $SWR = 1.5$  and a Return Loss = 14 dB.

When the connectors on the DUT differ from those on the reflectometer test port an adapter is often employed to make the measurement. However, the limitation to measurement accuracy caused by the adapter reflections is often severe. Suppose an adapter with 1.22 SWR ( $\rho = 0.10$  and R.L. = 20 dB) is used in a reflection measurement. Since the adapter has a  $\rho$  of 0.10, it is not possible to measure DUT  $\rho$  of less than 0.10. Otherwise, the DUT reflection may be obscured by the adapter reflection. Because the adapter reflection is a constant error quantity for all measured values  $\rho$ , it is added to the coupler directivity to obtain an effective reflectometer system directivity denoted by the A term in equation (5). Directional couplers like the 11691D and 11692D are available with precision APC-7 connectors on the main arm output, so low SWR APC-7 adapters can be utilized. The use of low-cost interseries adapters generally leads to an effective directivity under 20 dB in the microwave frequency range.

### SWEPT SLOTTED-LINE MEASUREMENTS

Slotted lines accomplish high-frequency swept impedance measurements by sampling standing waves along a transmission line. Because the directivity performance of many coax reflectometers deteriorates above 8 GHz, the swept slotted line with its consistent high-frequency performance is an important impedance measuring technique. It is particularly useful in the measurement of small reflection coefficients (small SWR).

Figure 30 exhibits the basic 8755/817B swept slotted-line system, operating from 1.8 GHz to 18 GHz. Sweeper output is fed through the modulator and a low-pass filter before entering the slotted-line sweep adapter. The sweep adapter is a short piece of slotted

line including a stationary probe with adjustable depth followed by a well-matched 6-dB attenuator. The detector stationary probe is matched to the detector movable probe on the slotted-line carriage, thus compensating for the frequency response of the probes as well as variations in sweeper output power. The 6-dB attenuator improves the source match. Note that a 181T variable-persistence oscilloscope is used as a display for the 8755A. Variable persistence or some other means of trace storage, such as time-exposure photography, X-Y recordings, etc., is required for swept SWR measurement.

Operation of a swept slotted line is best understood by first recalling a single-frequency slotted-line measurement. From transmission-line theory, it is known that a uniform, lossless line terminated in an impedance other than its characteristic impedance will have two traveling waves on it. Besides the forward or incident traveling wave,  $E_i$ , there will be a reverse or reflected traveling wave,  $E_r$ , whose magnitude is dependent on the terminating impedance and the value of  $E_i$ . While the reflectometer measures  $E_i$  and  $E_r$  through the use of directional couplers, the slotted line measures the standing wave resulting from the interaction of  $E_i$  and  $E_r$ .

$$SWR = \frac{E_{max}}{E_{min}} = \frac{E_i + E_r}{E_i - E_r} = \frac{1 + \rho}{1 - \rho} \quad (3)$$

Thus moving the slotted-line probe over a minimum of one-half wavelength at a single frequency insures the detection of  $E_{max}$  and  $E_{min}$  and the determination of SWR. The swept slotted line operates in a similar fashion. However, the source is swept internally, and the detector probe is moved over a distance of at least one-half wavelength at the lowest frequency so that both  $E_{max}$  and  $E_{min}$  of the standing wave are sampled. Instead of reading out  $E_{max}$  and  $E_{min}$  at a single frequency the 8755A/181T can be used to read out the maxima and minima at all frequencies over which the source is swept. Since maxima and minima

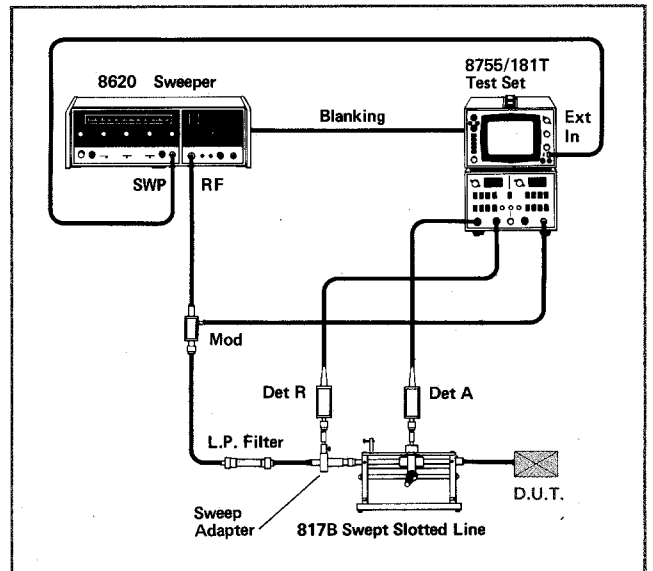
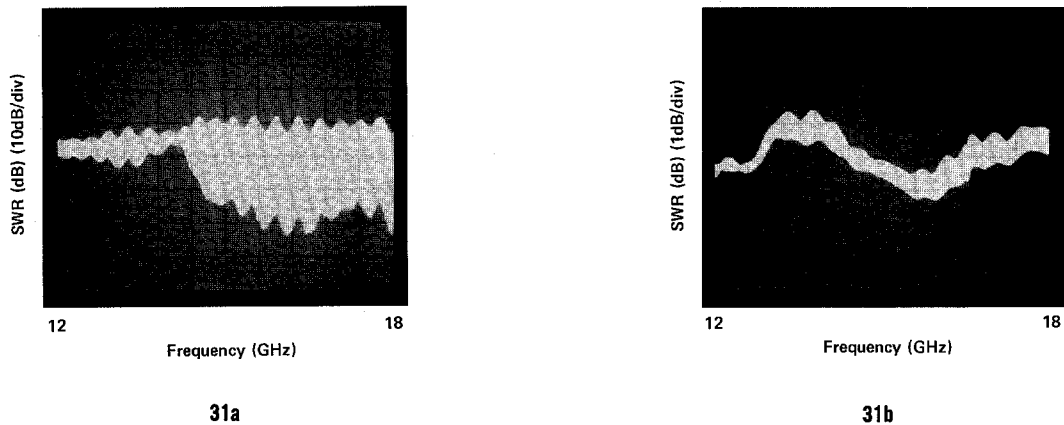


Figure 30. HP 817B Swept Slotted-Line System for swept SWR measurements between 1.8 and 18 GHz. An 8755 system with 181T storage oscilloscope is used to detect and store the data.



**Figure 31.** Displays resulting from typical swept SWR test with the 817B/8755 system in Figure 30: a) low-pass filter with a 13 GHz cut-off frequency and b) a 10-dB pad. The measured SWR (dB) of the pad is less than 1 dB (1.12 SWR) over the full band.

do not occur at the same point on the line at all frequencies, several sweeps are required, each with the probe at a different position on the slotted line. The result is an envelope like the ones shown in Figure 31.

The lower level of the envelope in Figure 31 represents  $E_{min}$  while the upper level represents  $E_{max}$ . Because the display is logarithmic, SWR (dB) can be read directly by measuring the vertical thickness of the envelope at the frequency of interest. This occurs because:

$$20 \log E_{max} - 20 \log E_{min} = 20 \log \left( \frac{E_{max}}{E_{min}} \right) = 20 \log SWR = SWR \text{ (dB)} \quad (6)$$

It follows directly from equation (4) in the introduction that:

$$SWR = \log^{-1} \left( \frac{SWR \text{ (dB)}}{20} \right) \quad (7)$$

The basic procedures for swept SWR measurements using the 817B swept slotted line with 8755/181T are outlined below.

### Set Up and Calibration

1. Set up equipment as shown in Figure 30 and set sweeper for maximum power over the frequency range of interest.
2. Remove R detector from sweep adapter and use it to measure the absolute power at the test port of the slotted line. (Be careful that the power level is appropriate for the DUT.)
3. Using the OFFSET CAL vernier and OFFSET dB thumbwheels, adjust the average insertion of the A probe to sample power 25 dB below the absolute level measured in step 2.
4. Return the R detector to the sweep adapter and terminate the slotted-line test port in its characteristic impedance. Adjust the average insertion of

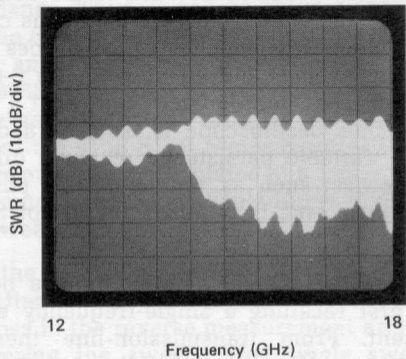
the stationary probe (R probe) to sample power 19 dB below absolute level measured in step 2.

### Measurement

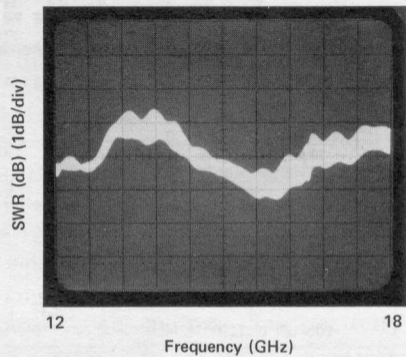
5. Connect the DUT to the slotted-line test port. Be careful to terminate two-port DUT's in their characteristic impedance ( $Z_0$ ).
6. Set 8755 for ratio measurement (A/R) and move the slotted-line carriage until a swept SWR (dB) envelope similar to those in Figure 31 is recorded. The OFFSET CAL vernier, OFFSET dB thumbwheels, and resolution push-buttons may all be used to obtain the most desirable display.
7. Store the display of the SWR (dB) envelope and observe SWR (dB) at the frequencies of interest.

In the measurement procedure, the insertion of the A-probe is adjusted to sample energy 25 dB below the incident signal level. The dynamic range available for SWR (dB) measurement is the difference between the absolute power level sampled by the probe and the detector noise level. For instance, if the incident signal level at the DUT is 0 dBm and the detector noise level is -50 dBm, the probe can sample maximum and minimum signal levels between -25 dBm and -50 dBm, allowing 25 dB of dynamic range [-25 dBm - (-50 dBm)] in SWR (dB) measurements (17.8:1 SWR). Insertion may be increased to measure larger values of SWR (dB), however errors resulting from probe reflections will also increase and this technique is rarely used to measure large SWR's (>3:1 SWR). The R-probe insertion is 6 dB above the A-probe insertion to compensate for the 6-dB attenuator in the sweep adapter.

When the SWR of two port devices with very low insertion losses is measured, the quality of the termination used becomes important. This occurs because any reflection from the load termination will add vectorially with the reflection from the DUT. Because of this problem, it has become a standard practice to use a sliding load, such as the HP 905A, to terminate the DUT.



31a



31b

**Figure 31.** Displays resulting from typical swept SWR test with the 817B/8755 system in Figure 30: a) low-pass filter with a 13 GHz cut-off frequency and b) a 10-dB pad. The measured SWR (dB) of the pad is less than 1 dB (1.12 SWR) over the full band.

A sliding load is simply a length of transmission line with a movable termination, permitting the phase angle of the voltage reflected by the load to be varied while the magnitude is held constant. By manipulating the phase angle of the load reflection, it is possible to separate the voltage reflected by the DUT from the voltage reflected by the load.

A useful technique is to mechanically couple the probe carriage to the sliding load so that the distance between the slotted line probe and the load termination is held constant. This keeps a fixed phase angle between the incident voltage,  $E_i$ , and the part of the reflected voltage due to the termination  $E_L$ . Thus the thickness of the swept SWR (dB) envelope becomes:

$$20 \log \frac{|E_i + E_L| + |E_r|}{|E_i + E_L| - |E_r|} \quad (8)$$

where  $E_r$  is the voltage reflected by the DUT. If  $|E_i| \gg |E_L|$  as it normally is, the thickness of the swept SWR (dB) envelope is due principally to  $E_r$  and is an excellent approximation of the SWR being measured. The principal effect of the load reflection,  $E_L$ , is to move the entire swept SWR (dB) envelope up or down on the display; the effect on envelope thickness is negligible.

### SWEPT SLOTTED-LINE ACCURACY

The primary sources of uncertainty in swept slotted-line measurements are residual reflections, slope, probe reflections, and instrument errors. As in the case of the reflectometer these terms may be combined into a composite error equation:

$$\Delta\rho = A + B\rho + C\rho^2 \quad (9)$$

The A term is composed of the residual reflections and slope of the slotted line. Residual reflections result from the output connectors on the line and the slot ends, while slope is due to mechanical tolerances causing the insertion of the probe to vary as it is moved on the carriage. These two terms correspond to effective directivity in a reflectometer system and represent the lower limit for  $\rho$  measurements using the slotted line. Probe reflections are the primary contributors to the B term.

The C term is composed entirely of the residual reflections of the slotted line; this is the same residual reflection term that combines with the slope error to form A.

Since the swept slotted line is primarily applied to the measurement of small  $\rho$ 's (SWR's), the B and C terms in equation (9) are usually not significant. In this situation, error analysis can be concentrated on the residual reflections and slope error comprising the A term. For the HP 817B slotted line, the residual reflections are 1.04 SWR ( $\rho = 0.0196$ ) at 18 GHz and slope error is 0.1 dB in SWR (dB) ( $\rho = 0.006$ ). Summing these two errors, an A term equal to 0.0256 (at 18 GHz) is obtained; 0.0256 can be converted to a return loss of 32 dB which is equivalent to the directivity error in reflectometer measurements. The Reflectometer Calculator may then be used to determine the uncertainty limits caused by residual reflections and slope errors. If adapters are utilized, adapter reflections as in reflectometer

measurements add directly to the A term, increasing the uncertainty.

In general, slotted lines offer greater accuracy than reflectometers but are more difficult to use. Also, careful measurement techniques are required in slotted-line measurements, or such factors as probe reflections caused by excessive coupling can contribute major inaccuracies. However, the swept slotted line is essential to the measurement of low  $\rho$ 's (SWR) such as those encountered on cables and connectors, at 18 GHz.

### DIRECTIVITY MEASUREMENTS

Since the directivity of directional couplers is often the limiting factor in reflectometer measurements of impedance, it is an important quantity to define and measure. Directivity is defined as the ratio in dB of the power in the secondary arm when all the power in the main arm is flowing in the forward direction to the power in the secondary arm when an equal amount of power in the main arm is flowing in the reverse direction. Measurement of waveguide coupler directivity is achieved with the setup in Figure 32. By replacing the waveguide components with their coax counterparts, the configuration or a similar configuration employing the 8755 system may be used to measure coax couplers. The setup in Figure 32 is identical to the basic reflectometer configuration of Figure 27; however, the reverse coupler is now the DUT. As in the reflectometer, the 415E SWR Meter is employed as an amplifier, and the sweeper is accordingly amplitude modulated at a 1-kHz rate.

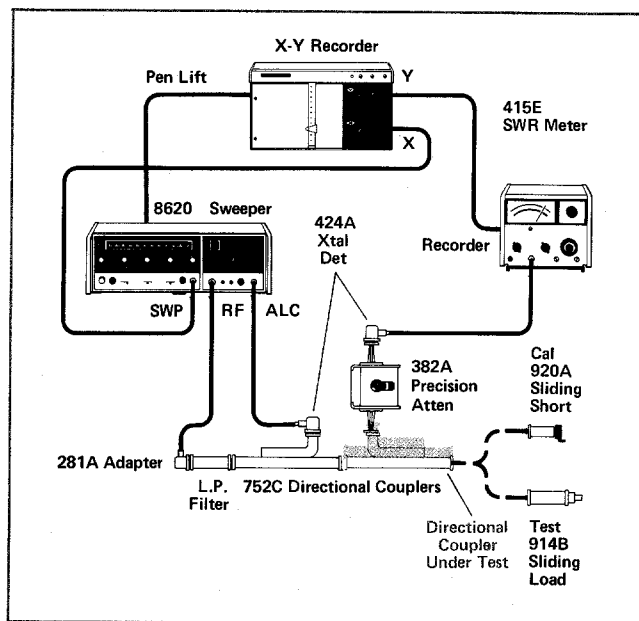
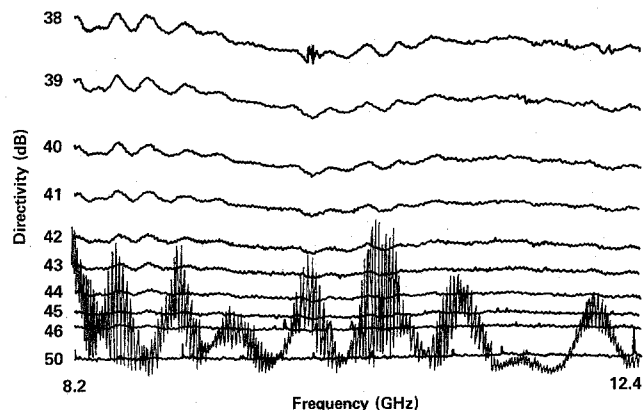


Figure 32. Swept directivity measurement system for waveguide directional couplers (2.6 to 40 GHz). The system is similar to the RF substitution reflectometer in Figure 29 and may be replicated in coax by substitution of the appropriate components. An 8755 system may be used in place of the 415E.

Calibration is established using a short with the precision attenuator set to specific values near the directivity of the coupler under test. Calibration grid lines are drawn on the X-Y recorder for each setting

of the precision attenuator. If a sliding short is utilized, it should be rapidly phased during each sweep so source match variation with load phase will be averaged about the calibration grids. After the grids have been drawn, the short is replaced by a sliding load and the precision attenuator set to zero.

With the sweeper set for a very long sweep time (>40 seconds), a final sweep is triggered and the sliding load continuously phased during the sweep. A typical X-Y recording is exhibited in Figure 33.

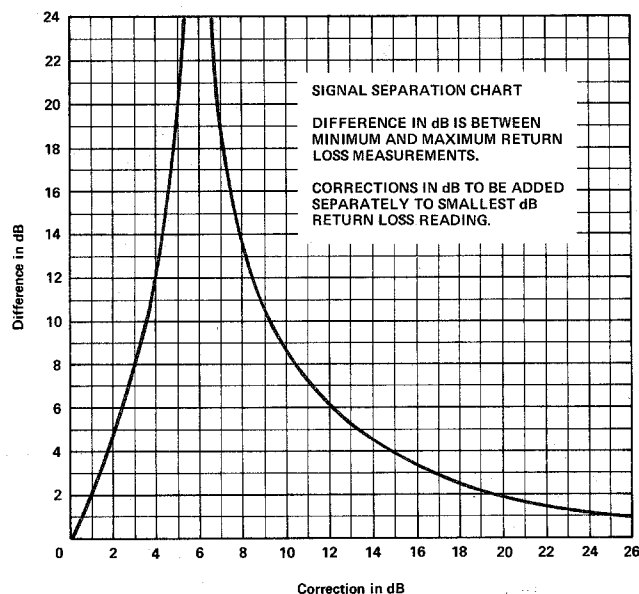


**Figure 33.** Typical X-Y recording for a swept directivity measurement of a precision, multihole, waveguide directional coupler. Note that the envelope created by phasing the sliding load is always below the specified 40-dB calibration grid. Thus it is not necessary to spot check the directivity at a CW frequency.

By phasing the load and sweeping slowly, all possible phase combinations of the directivity signal and the load return loss are encountered at the reverse detector. Thus the detected signal swings between the vector sum and difference of the two signals as the load is phased. The coupler under test is within its directivity specification if the swing, represented by envelope in Figure 33, lies below the specified directivity calibration grid. For instance, if the coupler under test had a coupling coefficient of 10 dB, a 0.46-dB transmission loss would be subtracted from the value of the swing noted on the X-Y recording. For coupling coefficients of 3 dB and 20 dB, the transmission losses are 3 dB and 0.04 dB respectively.

If the swing exceeds the specified directivity calibration grid, a more precise determination of directivity can be made at a single frequency using the Signal Separation Chart in Figure 34. The sweeper should be set to the frequency of interest (in CW mode) and the short reconnected to the coupler under test. The precision attenuator can now be set to a value NEAR the expected directivity, and the RANGE and GAIN controls used to establish a convenient reference level on the

415E. The short is replaced by a sliding load, and the attenuator decreased for an on-scale reading on the 415E.



**Figure 34.** Signal Separation Chart used for separating two signals when their sum and difference are known.

Phase the load and note the maximum and minimum values on the 415E. The precision attenuator may be used to determine the minimum and maximum signal levels (in dB) with respect to the original reference level established on the 415E during calibration. This is accomplished by phasing the load for either a maximum or minimum and using the attenuator to re-establish the reference level on the 415E. Once the maximum and minimum are obtained their difference can be calculated and the Signal Separation Chart applied.

The difference in dB of the maximum and minimum signal levels is entered on the ordinate of the Signal Separation Chart in Figure 34. The two curves on the chart are intersected on a horizontal line from the ordinate entry, and the two correction factors noted on the abscissa (directly below the intersections). For instance, if the difference between the maximum and minimum signals is 12 dB, the two correction factors would be approximately 4 dB and 8.5 dB.

The two correction factors are added separately to the minimum dB reading noted in the sliding load test. The two resultant numbers are the actual values of coupler directivity less transmission loss and the sliding load return loss. However, it is still not known which signal level is the directivity and which is the sliding load reflection. To resolve this ambiguity, degrade the sliding load by taping a piece of solder on the load and repeat the test. A second set of separated signals will be obtained; one signal level in each set should remain unchanged. The signal level plus the transmission loss of the coupler is the directivity.

In coax measurements, it is difficult to degrade the sliding loads. Therefore, it is usually convenient to use either a different load or a different coupler for the second measurement.

## SOURCE SWR MEASUREMENTS

Because source SWR, like directivity, causes uncertainty in high frequency measurements, it is a useful term to quantify. A system for measuring the output SWR of microwave sweepers is shown in Figure

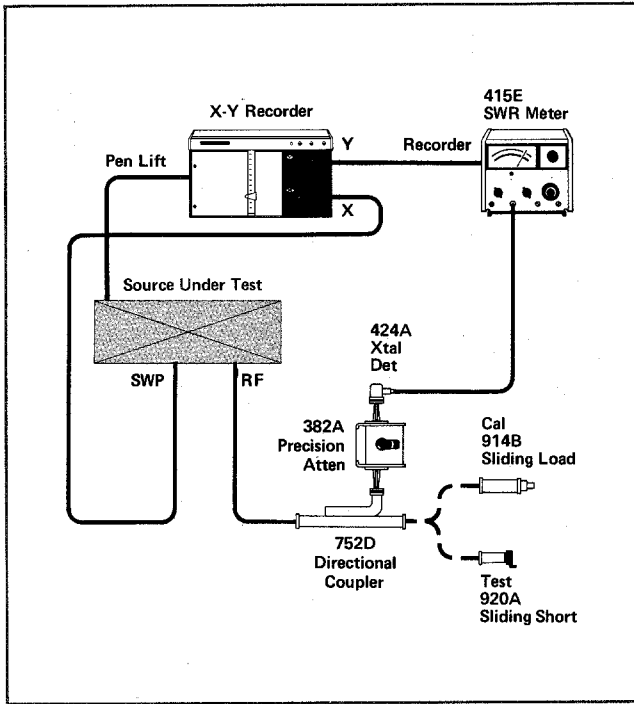
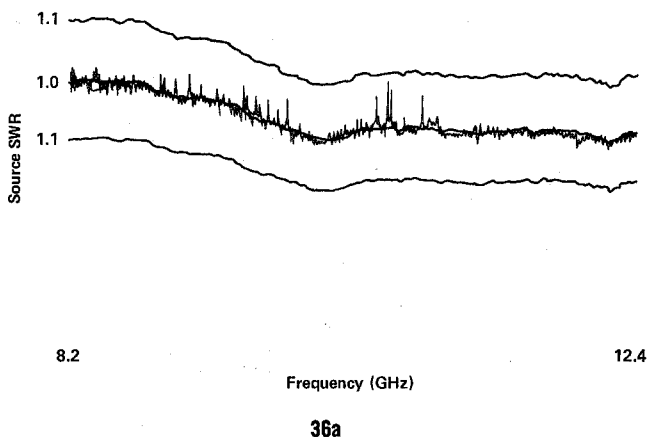


Figure 35. System for measuring the source SWR of sweepers with final output in waveguide.

35. Whether the sweeper is leveled (internally or externally) or not, the final output, either front panel or leveling coupler, must be in waveguide. The system in Figure 35 cannot be replicated in coax because high-quality sliding shorts are not available.

The results of a swept-source SWR test are shown



in Figure 36. Both X-Y recordings were obtained from a sweeper with an external waveguide leveling loop. Figure 36 (a) indicates that the leveled source has better than a 1.1:1 source SWR. In Figure 36 (b), the leveling loop is opened, and source SWR is close to 2:1.

With the coupler output terminated in a sliding load and the precision attenuator set to specific values of source SWR, three calibration grids are plotted. The sliding load is replaced by a sliding short and a final sweep triggered. The sweep time should be long (>40 seconds), and the sliding short should be phased continuously during the sweep. As the short is phased the sweeper will see all possible phase angles of reflection coefficient with unity magnitude. Any portion of the short reflection that is re-reflected by the sweeper will add with the incident signal and be coupled to the detector. The result is the envelope seen in Figure 36.

Precision attenuator settings for the three calibration grids are determined using the formula  $6 \text{ dB} + 20 \log (1 \pm \rho_s \rho_L)$ .  $\rho_s$  is the reflection coefficient corresponding to a specific value of source SWR while  $\rho_L$  is equal to unity since a short is used as the load during test. 6 dB is introduced as an arbitrary offset about which the upper and lower calibration limits may be plotted. Thus the precision attenuator settings for three calibration grids are:

$$\text{Upper grid setting} = 6 \text{ dB} + 20 \log (1 + \rho_s) \quad (10)$$

$$\text{Middle grid setting} = 6 \text{ dB} \quad (11)$$

$$\text{Lower grid setting} = 6 \text{ dB} + 20 \log (1 - \rho_s) \quad (12)$$

For example, a SWR of 2:1 corresponds to a  $\rho$  of 0.33; substituting into the equations (10), (11), and (12), the corresponding attenuator settings are 2.5 dB, 6 dB, and 8.5 dB respectively.

The accuracy of source SWR measurements is dependent on the high directivity (>40 dB) of waveguide directional couplers, assuming that all the signal variations seen at the measurement detector are caused by source match. Because coax couplers typically have lower directivities (usually 30 dB), small values of source SWR cannot be distinguished in coax systems.

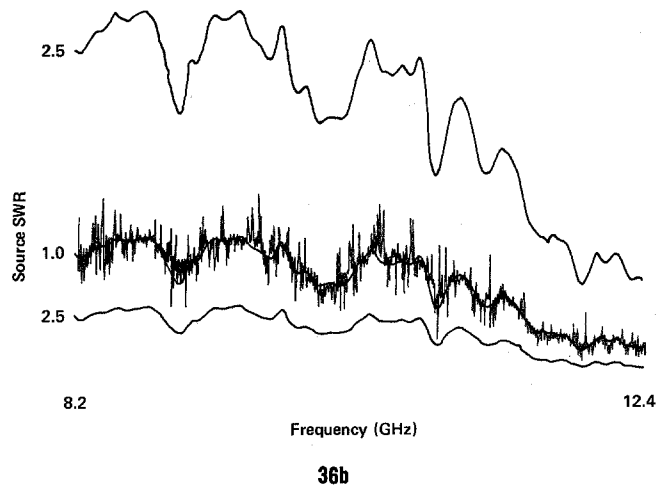


Figure 36. Swept source SWR measurement for a) a sweeper externally leveled in waveguide and b) the same sweeper with the leveling loop open. From a) and b) above it is evident that leveling improves sweeper source match from a near 2:1 SWR to less than 1.1:1 SWR.

During the plotting of calibration grids, rapidly phasing the load will cause fine-grain variations in the grid. Similarly to return-loss measurements, the effects of the load reflections on the measurement may be min-

imized by taking the mean of the fine-grain variations as the true value of the grid line. The 415E in Figure 35 acts solely as an amplifier for the vertical input of the X-Y recorder and could be supplanted by an 8755.

# TRANSMISSION

Description of the behavior of multi-port networks as a function of frequency entails the measurement of transmission characteristics as well as impedance characteristics. As in impedance measurements, high frequency transmission measurements require the application of transmission-line theory and the subsequent sampling of the appropriate traveling waves.

Network transmission characteristics are usually expressed in terms of a transmission coefficient,  $\tau$ .  $\tau$  is defined as the change in power level (at the load), caused by inserting a network between a reflectionless source and load. According to transmission-line theory, reflectionless implies that both source and load impedances are equal to  $Z_0$ , where  $Z_0$  is the characteristic impedance of the system. Under these conditions, the change in power level is purely a function of the device under test. Mathematically,  $\tau$  is defined in terms of the incident and transmitted traveling waves:

$$\text{Transmission Coefficient Magnitude: } \tau = \left| \frac{E_{\text{trans}}}{E_{\text{inc}}} \right| \quad (1)$$

$$\text{Loss or Gain (dB): } \tau(\text{dB}) = -20 \log \tau \quad (2)$$

The transmission coefficient magnitude defined in equation (1) may be less than unity (attenuation or loss) or greater than unity (gain). The basic measurement is the same in either case; however, care must be taken to assure that the incident and transmitted power levels are consistent with the requirements of both the network under test (i.e. amplifier linearity) and the measurement system (i.e. detector burn-out).

Broadband swept-transmission measurements are accomplished by sampling both the incident and transmitted traveling waves with respect to the network under test.  $\tau$  is determined by performing the ratio of the two detected signal levels. Directional couplers, directional bridges, and power splitters are typically employed to sample the incident wave. The transmitted wave may be sampled directly at the output port of the network under test or through the auxiliary arm of a directional coupler. However, the primary concern in any transmission measurement configuration is maintenance of the source and load impedances near  $Z_0$ .

A source impedance near  $Z_0$  is obtained either by leveling the sweeper or directly performing the ratio of the incident and transmitted signal. A leveled sweeper not only maintains  $|E_{\text{inc}}|$  at a constant level but also makes the sweeper appear close to a  $Z_0$  source. However, instantaneously sampling and ratioing the incident and transmitted signals has the same effect as leveling in maintaining a  $Z_0$  source and in compensating for variations in  $|E_{\text{inc}}|$  (see Appendix A).

Maintaining the load near  $Z_0$  is obtained by minimizing the reflections from the detector used to detect

the transmitted signal. This is usually accomplished by employing detectors with low reflections or isolating the detector in the auxiliary arm of a directional coupler with the main arm terminated in a  $Z_0$  load. The load or output detector may also be isolated through the use of pads or ferrite isolators.

The objective of this section is the development of the techniques for measurement of transmission coefficients (both gain and attenuation). Advantages, applications, and accuracy of the various techniques will be discussed in addition to the basic measurement procedures. Simultaneous reflection/transmission measurements will be presented in the conclusion of the section.

## COAX TRANSMISSION MEASUREMENT WITH DIRECTIONAL COUPLERS

Swept-transmission data like that shown in Figure 37 can be obtained from the 8755 transmission measurement system in Figure 38. Wide applicability in

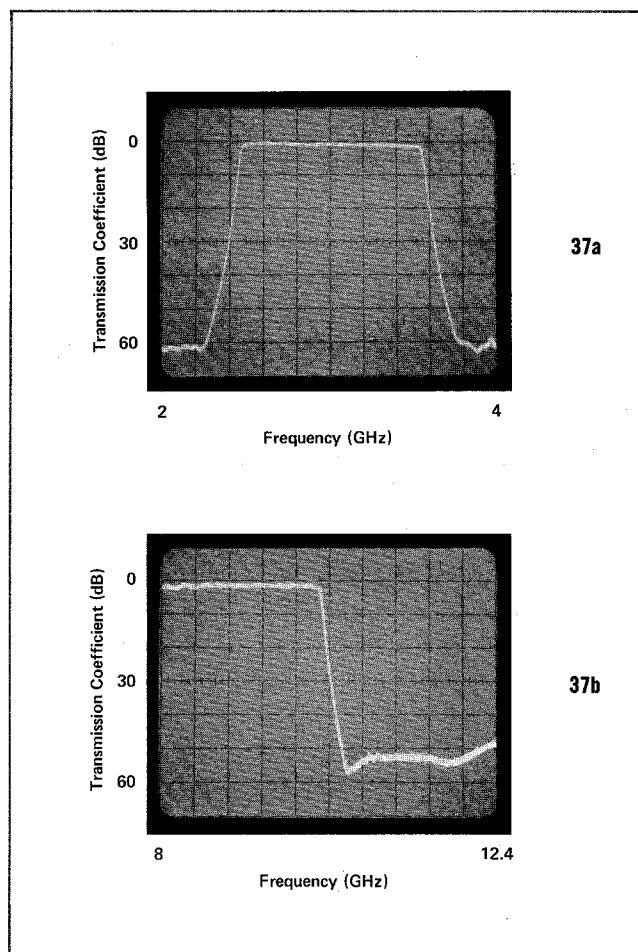


Figure 37. Transmission measurements of a) bandpass filter (2.5 to 3.5 GHz) and b) low-pass filter (10 GHz) as seen on the display of the 8755 Frequency Response Test Set.

swept measurement of both gain and attenuation is achieved as a result of the system's speed and versatility. Because of the 8755 system's broadband detection characteristics, the configuration shown in Figure 38 is capable of measurements from 15 MHz to 18 GHz, assuming the sweeper and directional coupler operate over the frequency range of interest.

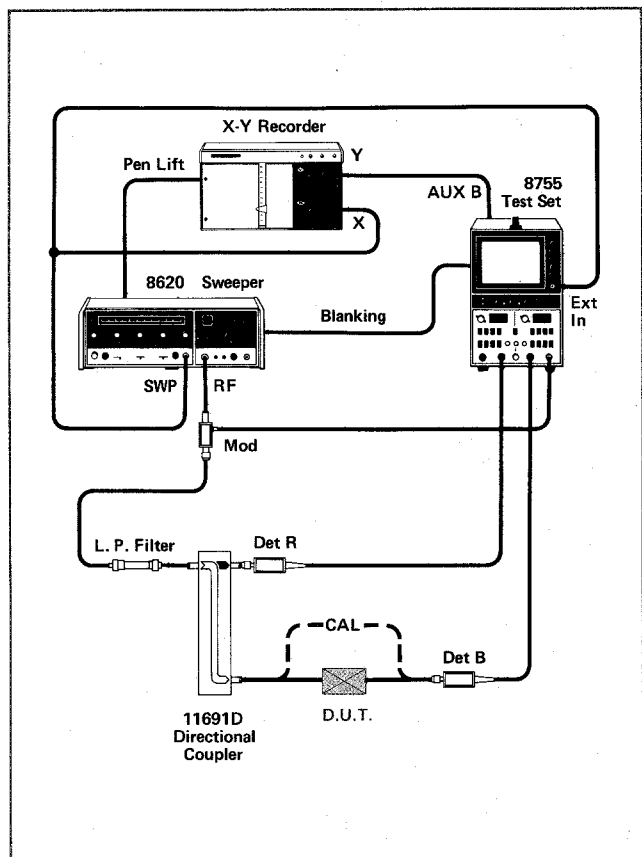


Figure 38. 8755 coax transmission measurement system utilizing the HP 11691D 2 to 18 GHz directional coupler.

In transmission measurements as in the reflectometer, the 8755 system's R detector samples the power incident on the DUT through the auxiliary arm of a directional coupler. During calibration the B detector is placed directly on the coupler main arm (see Figure 38). Using the 8755 system's capability to measure absolute power, sweeper output power at the coupler main arm is adjusted to a level consistent with operating characteristics of the DUT and the dynamic range requirements of the measurement system. After the appropriate power levels have been chosen, calibration for a 0 dB transmission coefficient is established with the 8755 system in a ratio measurement mode. The measurement is accomplished by inserting the DUT between the coupler main arm and the B detector. Sweep speeds may be adjusted to accommodate data readout on a continuous CRT display or an X-Y recorder.

Because the 8755 system has ratio-measurement capabilities, the output of the sweeper in Figure 38 is not necessarily leveled. Unless the DUT is input power sensitive, leveling is not required as it was in most

conventional swept-transmission measurement systems. The incident-signal sample coupled through the coupler auxiliary arm may be fed either to the sweeper in a leveling loop or directly to a ratio measuring display like the 8755 system. In both cases, compensation for variations in incident power is achieved while source match is improved to a near  $Z_0$  condition ( $<1.2$  SWR). However, ratio-measurement systems are generally preferred because set up and calibration are quicker and easier than in most conventional leveled systems (see Appendix A).

Since the 8755 system utilizes broadband detectors, a low-pass filter must be included in many transmission measurement setups to eliminate sweeper harmonics and insure maximum dynamic range. While a low-pass filter is generally adequate protection against inaccuracies caused by spurious signal levels, care must be taken in some measurements to avoid modulator feedthrough and sweeper subharmonics. Feedthrough of the 27.8 kHz modulation signal from the 11665B modulator may cause errors in certain gain measurements, but this can be avoided by adding an HP 11668A 50-MHz high-pass filter after the modulator. Similarly, sweepers using multiplier techniques generate subharmonics as well as harmonics, necessitating the use of bandpass rather than low-pass filters.

Both gain and attenuation measurements are possible with 8755 transmission measurement system shown in Figure 38. In the discussion of measurement procedures, attenuation will be dealt with first followed by a review of any procedural or setup changes required to determine gain.

### Set Up and Calibration

1. Set up the equipment as shown in Figure 38 and set the sweeper to sweep the frequency range of interest.
2. Use the 8755A position controls to adjust the 0 dB/0 dBm position line to a convenient graticule, hence referred to as the position graticule.
3. Connect the B detector to the main arm of the directional coupler. With OFFSET CAL in the OFF position adjust sweeper output power for approximately +10 dBm at coupler main arm (if  $<+10$  dBm, adjust for maximum). This assures maximum dynamic range; however, care should be taken not to exceed the input power specification of the DUT. Turning the OFFSET CAL to OFF calibrates the 8755 system in absolute power (dBm).
4. Set 8755 system for ratio measurement (B/R).
5. With the OFFSET dB at  $\pm 00$  and OFFSET CAL to ON, use the OFFSET CAL vernier to average any variation in the calibration trace about the position graticule. A grease-pencil recording on the CRT may be used to store the variations in the calibration trace for future reference.

Note: The 8755 transmission measurement system is now calibrated for the swept measurement of transmission coefficient. If the OFFSET CAL ver-

nier is moved during measurement, the calibration will be destroyed.

### Measurement

6. Insert the DUT between the coupler main arm and the B detector.
7. Use the OFFSET dB thumbwheels and the RESOLUTION push buttons to achieve a suitable display.
8. The OFFSET dB thumbwheels can be used for accurate substitution measurements and digital readout (to the nearest dB) of attenuation loss at any point on the trace. Once the thumbwheels have been used to bring a point of interest to the position graticule, resolution may be increased without the trace leaving the screen.

Two additional factors are considered in a gain measurement:

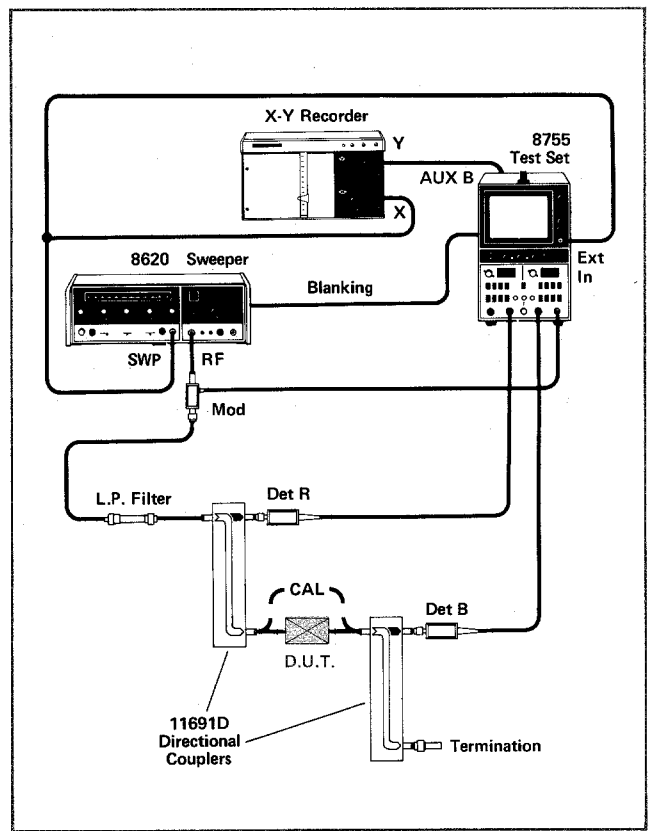
9. Add the 11668A (50-MHz high-pass filter) in series with the 11665B modulator.
10. Adjust the sweeper output-power level at the coupler main arm so that the absolute power is consistent with the input power specifications of the DUT and the dynamic range requirements of the 8755 system. This is to avoid saturation of the DUT.

The 11668A high-pass filter prevents amplification by the DUT of the 27.8 kHz modulation feedthrough. Two points are critical in determining the incident power level in gain measurements. The power level must be in the normal input range of the DUT so that saturation does not occur. Also, the input power level plus the expected gain of the DUT must not exceed +10 dBm which is the upper limit of 11664A detector's specified measurement range. If these two criteria are conflicting, i.e. the normal DUT input power plus gain exceeds +10 dBm, a pad may be introduced between the output of the DUT and the detector. As long as the pad is used in calibration as well as measurement, gain can still be read directly from the OFFSET dB thumbwheels.

### Coupling Compensation

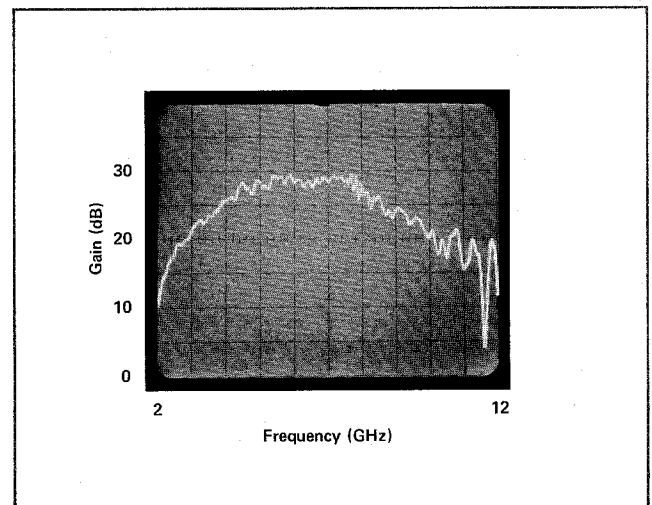
In the single coupler configuration of Figure 38, only the R detector sees the coupling variation with frequency which is typically  $\pm 1$  dB for coax couplers. Using another identical coupler, the setup in Figure 39 cancels most of the coupling variation as well as improving the effective detector match. The effect of coupling variation with frequency is reduced to the tracking between couplers which is typically  $\pm 0.5$  dB. Impedance match at the DUT output is improved from the SWR of the detector, typically 1.5 SWR, to the main-line SWR of the directional coupler, typically 1.3 SWR. The main arm output of the coupler must be terminated in its characteristic impedance.

This technique trades dynamic range in attenuation measurements for flatness. If the incident power at the DUT is the same as in the uncompensated setup, dynamic range is decreased by the coupling factor. Assuming +10 dBm incident power and 20 dB nominal

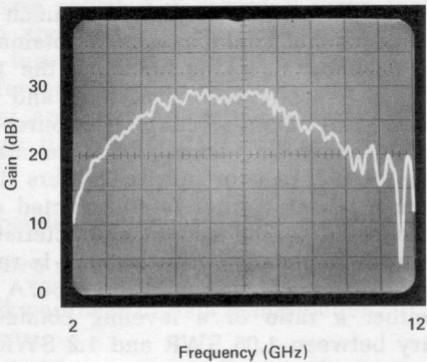


**Figure 39.** Coax transmission measurement system employing coupling compensation. The second coupler compensates the transmitted signal for the coupling variation seen at the R detector. However, the technique gives up some dynamic range in attenuation measurements to achieve flatness.

coupling, the dynamic range of the compensated configuration is 40 dB as opposed to the 60 dB available in the uncompensated setup. Of course, the dynamic range of gain measurements is unaffected by the addition of the compensating coupler (see Figure 40).



**Figure 40.** Broadband gain measurement of a 4 to 8 GHz TWT amplifier. The roll-off in gain outside of its normal operating region is clearly observable. The measurement was accomplished with the system in Figure 39.



**Figure 40.** Broadband gain measurement of a 4 to 8 GHz TWT amplifier. The roll-off in gain outside of its normal operating region is clearly observable. The measurement was accomplished with the system in Figure 39.

The measurement procedure for the setup in Figure 39 is essentially the same as for the single coupler configuration in Figure 38. The two couplers are connected directly together for calibration and the DUT inserted for measurement.

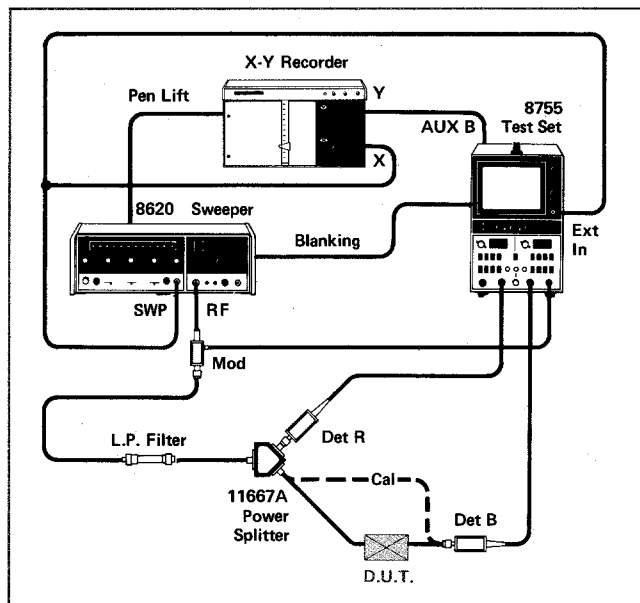


Figure 41. Coax transmission measurement system using the 11667A (dc to 18 GHz) power splitter.

## COAX TRANSMISSION MEASUREMENTS WITH POWER SPLITTERS

An 8755 transmission measurement system utilizing a 11667A power splitter is shown in Figure 41. Tracking between output arms, source match, and dc to 18 GHz frequency coverage are the primary advantages of using a power splitter instead of a directional coupler (or couplers) in gain and attenuation measurements. The only real disadvantage of the power splitter is that 6 dB more sweeper power is needed to obtain the same dynamic range in attenuation measurements.

Tracking errors are minimized, and the problem of coupling variation vs. frequency is eliminated because of the flat tracking response between output arms of the power splitter. This usually results in a much flatter calibration trace (or grid line) than can be obtained with conventional couplers. Tracking error for the 11667A power splitter is typically between 0.1 dB and 0.2 dB compared to  $\pm 1$  dB in most couplers. Source-match errors are also minimized because of the matching characteristics of two-resistor power splitters like the 11667A. When a power splitter is constructed of two resistors, each equal to the system characteristic impedance, a source impedance very near  $Z_0$  is realized. Typical source SWRs achieved with the 11667A power splitter in either a ratio or a leveling configuration generally vary between 1.05 SWR and 1.2 SWR. Conventional power splitters of three-resistor construction do not exhibit good source-match characteristics. (See Appendix A.) The measurement configuration in Figure 41 is particularly convenient because the 11667A power splitter operates from dc to 18 GHz. Directional couplers like those used in Figures 38 and 39 operate over much narrower bandwidths.

In certain attenuation measurements where limited sweeper output power is available, the 6-dB loss that occurs in both arms of the 11667A power splitter may limit dynamic range. In the corresponding configuration shown in Figure 28, the main arm transmission loss of a 20-dB directional coupler is a negligible 0.04 dB. This means that approximately +10 dBm of the swept power is required at the coupler input for 60 dB of dynamic range while +16 dBm is required at the power splitter input to obtain the same dynamic range.

The operating procedure for the measurement configuration in Figure 41 is fundamentally the same as in the two configurations using directional couplers. The R detector and B detector are connected directly to the output arms of the power splitter, and the incident power level optimized for the input specifications of the DUT and the maximum dynamic range. Calibration is established in ratio mode (B/R), and the measurement accomplished by inserting the DUT between the power splitter and the B detector. The results of several high resolution transmission measurements shown in Figure 42, capitalizing on the flat tracking response of the 11667A power splitter. The transmission characteristics of several other broadband devices are shown in Figure 43.

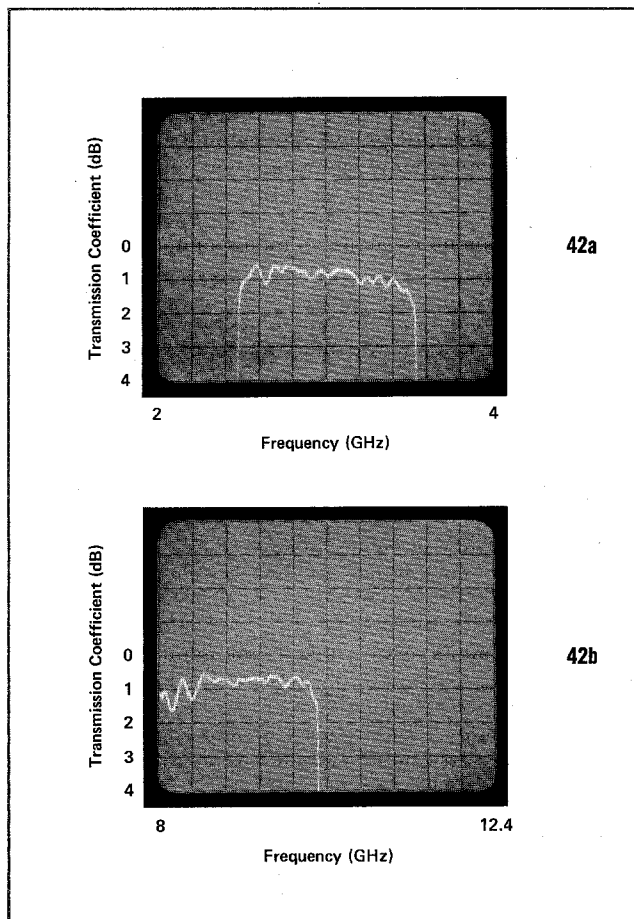
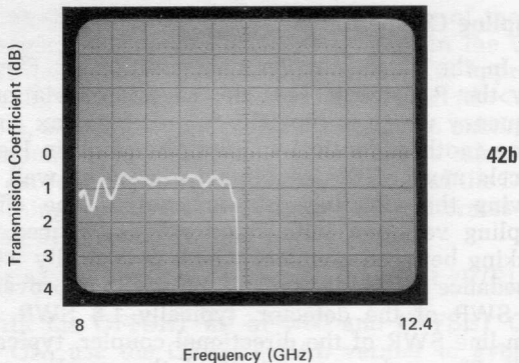
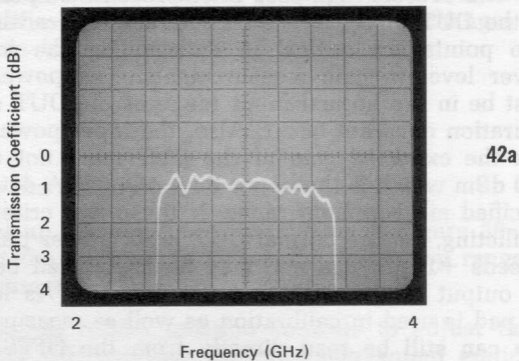


Figure 42. High resolution transmission measurements of the pass-band ripple in a) bandpass filter (2.5 to 3.5 GHz) and b) low-pass filter (10 GHz). Both measurements were made with the system in Figure 41, capitalizing on the power splitter's flat tracking. These are the same filters measured in Figure 37.

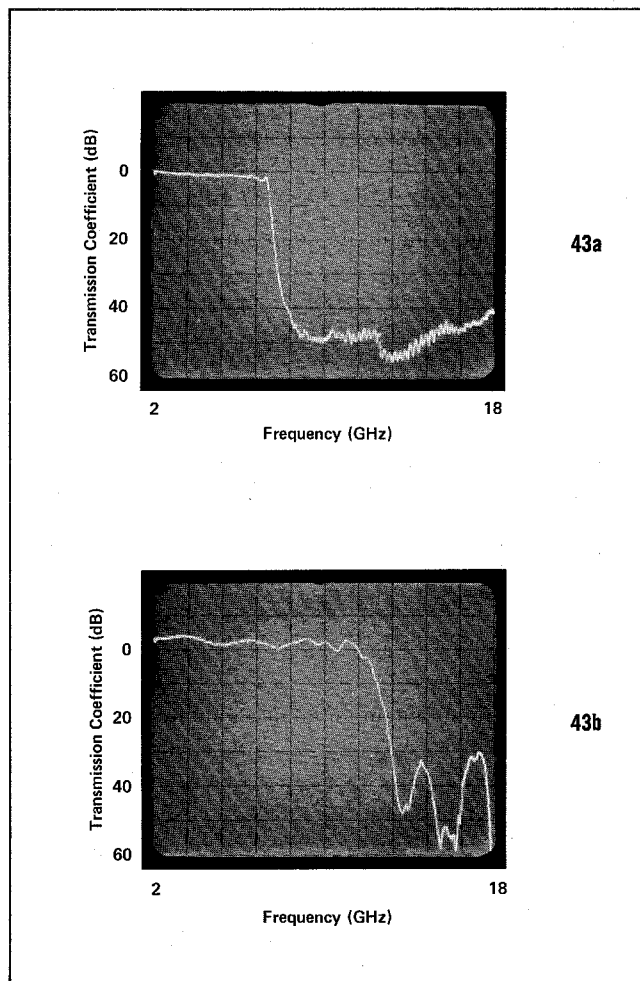


**Figure 42.** High resolution transmission measurements of the pass-band ripple in a) bandpass filter (2.5 to 3.5 GHz) and b) low-pass filter (10 GHz). Both measurements were made with the system in Figure 41, capitalizing on the power splitter's flat tracking. These are the same filters measured in Figure 37.

When the power splitter is used to make attenuation measurements in excess of 40 dB, spurious signals generated at the R detector may feed through to the B detector, causing added measurement uncertainty. Elimination of the spurious signals is achieved by introducing a 10-dB pad between the power splitter and the R detector. Since incident power is reduced, spurious signal levels are correspondingly reduced, and greater isolation between the two detectors provided. Because pads normally have reasonably flat frequency-response characteristics, there is little deterioration in tracking between arms.

## COAX TRANSMISSION MEASUREMENTS SUMMARY

Several transmission measurement configurations, two using directional couplers and one using a power splitter, have been presented thus far. To clarify the typical advantages and applications, the following summary is presented.



**Figure 43.** Broadband transmission measurements of a) low-pass filter (6.8 GHz) and b) the coupling coefficient of 2 to 10 GHz directional coupler. The nominal coupling coefficient of the coupler shown in b) is 10 dB; notice the rapid roll-off in coupling after 11.6 GHz.

## Measurements with Directional Couplers

### SINGLE COUPLER (Figure 38):

**Advantages:** Maximum dynamic range in attenuation measurements is achieved with minimum sweeper power.

**Disadvantages:** Coupling variation of  $\pm 1$  dB (seen at R detector only) makes high resolution measurements difficult and contributes to tracking errors.

**Applications:** General transmission measurements and high attenuation measurements, 40 dB to 60 dB (filter rejection bands).

### COUPLING COMPENSATION (Two Couplers, Figure 39):

**Advantages:** Reduces the effect of coupling variation from  $\pm 1$  dB to  $\pm 0.5$  dB (typical).

**Disadvantages:** Usually sacrifice 20 dB of dynamic range in attenuation measurements and cost of additional coupler.

**Applications:** Gain measurements; high resolution measurements (low-loss devices).

## Measurements with a Power Splitter

**Advantages:** Tracking between output arms, 0.1 dB to 0.2 dB (typical), effective source SWR, 1.05 SWR to 1.2 SWR (typical), widest operating range, dc to 18 GHz.

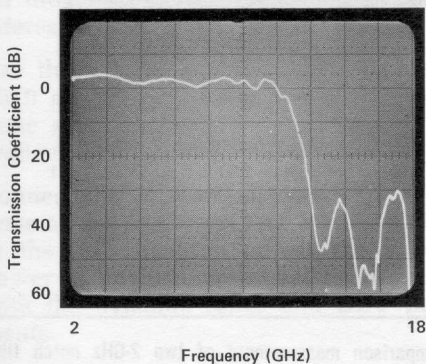
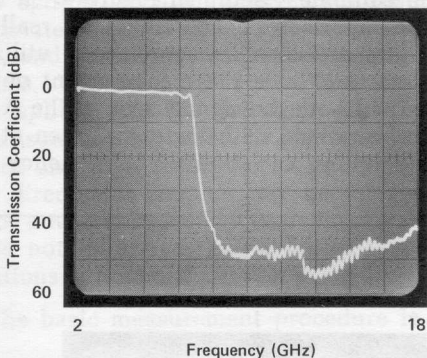
**Disadvantages:** 6-dB loss in both arms may limit dynamic range, low isolation (12 dB) between output arms may allow feed-through of spurious signals.

**Applications:** All general transmission measurements, best technique for measuring low-loss devices with high resolution.

Another common technique for transmission measurements involves storing a measured reference level (i.e. grease pencil, X-Y recorder) when the detector is directly connected to an unlevelled source. Next the DUT is inserted and a second measurement made with the difference equaling insertion loss or gain. The advantages are low cost and maximum dynamic range. However, the disadvantages are severe:

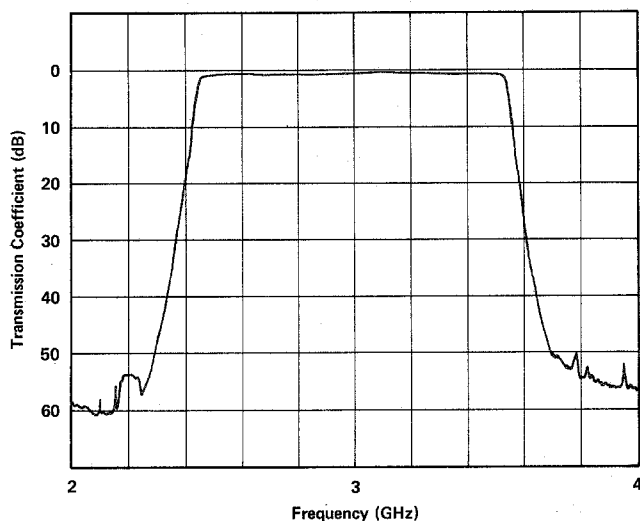
1. dependence on source level stability
2. source match error
3. awkwardness of data manipulation.

X-Y recording of transmission data may be acquired by addition of an X-Y recorder to any of the three measurement setups (see Figures 38, 39, and 41). Since the auxiliary outputs on the 180T mainframe (AUX A and AUX B) provide 0.5 volts/scale division, a recording of any trace at any resolution may be ob-



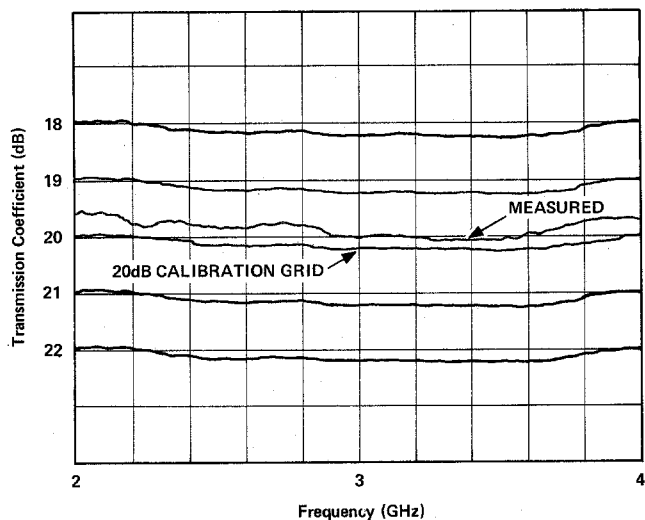
**Figure 43.** Broadband transmission measurements of a) low-pass filter (6.8 GHz) and b) the coupling coefficient of 2 to 10 GHz directional coupler. The nominal coupling coefficient of the coupler shown in b) is 10 dB; notice the rapid roll-off in coupling after 11.6 GHz.

tained after recorder has been calibrated initially. A typical recording is shown in Figure 44.



**Figure 44.** X-Y recording of the transmission loss through a band-pass filter. The recording could have been made with any of the 8755 systems in Figures 38, 39, and 41.

Figure 45 exhibits the results of high-resolution attenuation measurement where calibrated grid lines have been plotted. The variations in the grid lines are caused by the tracking errors (frequency response) of the measurement system. Calibration tracking errors are essentially eliminated by plotting the grids, and the same grids may be used for many measurements as long as the system is not turned off or recalibrated.



**Figure 45.** High resolution attenuation measurement of a 20-dB pad. Several calibration grid lines are plotted on the X-Y recorder before the actual insertion of the DUT, allowing calibration tracking errors to be subtracted from the measurement. Similar results could have been obtained using a grease pencil on the CRT.

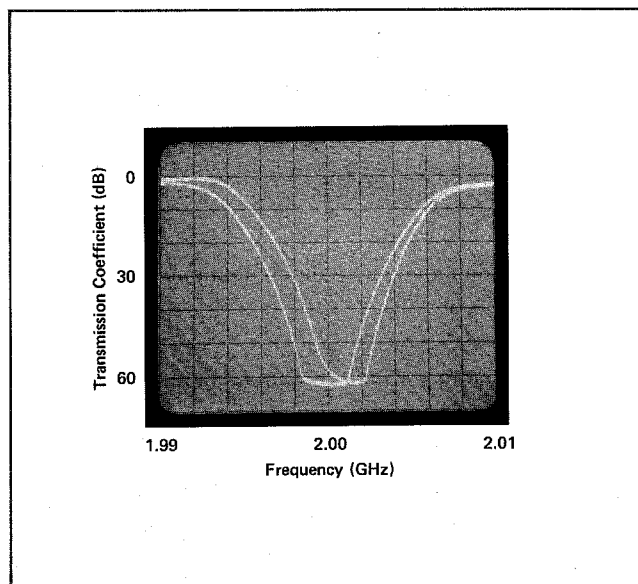
In a similar fashion, a grease pencil may be used to store the transmission calibration trace (or traces) on the CRT. During the measurement, the OFFSET dB

thumbwheels are used to compare the measured trace to the grease-pencil recording of the calibration trace; the RESOLUTION must be at the same level as it was in calibration. This allows calibration tracking errors to be subtracted from the measurement, enhancing accuracy in the same manner as grid lines on the X-Y recorder. Both grease-pencil and X-Y recording techniques are widely used methods of accuracy enhancement in transmission measurements.

## COAX COMPARISON MEASUREMENTS

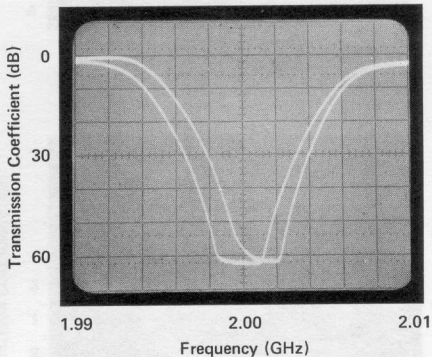
It is often useful in both design and test situations to compare the transmission characteristics of two components. For instance, it may be desirable to designate a particular component as a standard and align the transmission characteristics of similar components to that of the standard. In other situations, such as troubleshooting, comparison data may be instrumental in locating faulty or misaligned devices. Figure 46 shows a comparison measurement made between two notch filters using the measurement configuration in Figure 47. Alignment of a component under test to a standard is achieved quickly and easily using the real-time CRT display.

From the equipment setup in Figure 47, it can be seen that a comparison measurement is really two simultaneous transmission measurements utilizing a common R detector. Since the measurement objective is comparison and both the signals seen at the A and B detectors will be ratioed with the signal seen at the R detector, the coupling variation with frequency is not

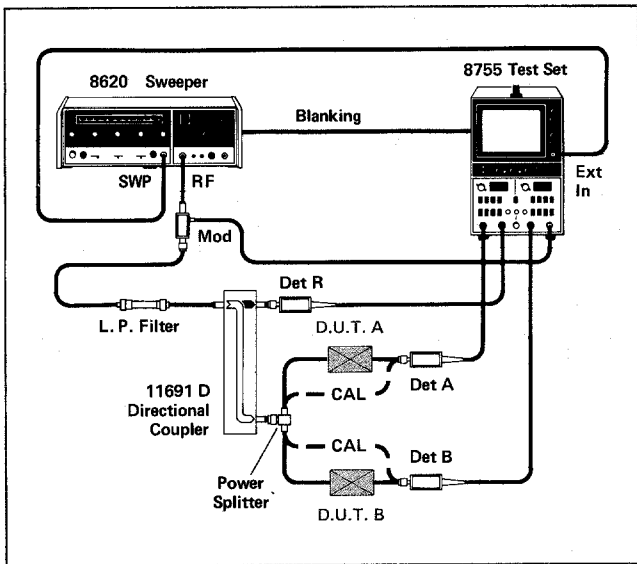


**Figure 46.** Comparison measurement of two 2-GHz notch filters. The 8755 system's real-time display allows rapid alignment of the two transmission characteristics.

a problem. However, it is important that the incident-signal levels at the power-splitter output arms be as nearly equal as possible both in calibration and test.



**Figure 46.** Comparison measurement of two 2-GHz notch filters. The 8755 system's real-time display allows rapid alignment of the two transmission characteristics.



**Figure 47.** 8755 system for making comparison measurements in coax. The system is essentially two simultaneous transmission measurements sharing a common R detector, resulting in displays like Figure 46. Note: The power splitter must be of three-resistor construction. (See Appendix A.)

The calibration procedure is initiated by connecting the A and B detectors to the two output arms of the power splitter. Incident power is adjusted to a level appropriate for both dynamic range and DUT requirements, and concurrent calibration established on both channels. The two DUTs are inserted between the power splitter and the detectors, and the appropriate comparison accomplished. If dynamic range is not a concern and high resolution comparisons are desired, the R directional coupler may be replaced by a two-resistor power splitter. The basic quality of the comparison is not improved, but a flatter display at higher resolutions is obtained.

The basic measurement procedure is outlined below.

### Set Up and Calibration

1. Set up the equipment as shown in Figure 47 and set the sweeper to sweep the frequency range of interest.
2. Use the 8755A position controls to adjust the 0 dB/0 dBm position line on both channels to the same graticule, hence referred to as the position graticule.
3. Connect the A and B detectors to the two output arms of the power splitter. With the OFFSET CAL in the OFF position adjust the sweeper output power to an incident signal level appropriate for both the dynamic range and DUT input requirements.
4. Set both channels of the 8755 system to ratio-measurement mode (A/R and B/R).
5. Set OFFSET dB to  $\pm 00$  and OFFSET CAL to ON on both channels. Use the OFFSET CAL vernier on the A channel to average any variation in the calibration trace about the position graticule. Use the

OFFSET CAL vernier on the B channel to overlay, as closely as possible, the second calibration trace on the first. The calibration traces on both channels should be displayed simultaneously.

Note: The 8755 system is now calibrated for a comparison measurement. Calibration will be destroyed if either OFFSET CAL vernier is changed.

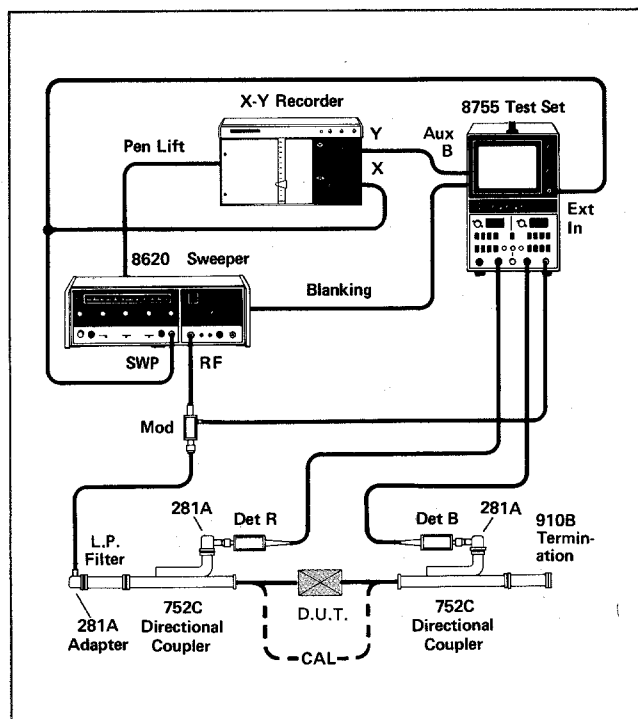
### Measurement

6. Insert the two DUT's between the power splitter and the two detectors.
7. Use the OFFSET dB thumbwheels and RESOLUTION push buttons to achieve an appropriate display. Of course, the controls on both channels must be identical for an accurate comparison.

X-Y recordings of comparison measurements may be drawn with a single-pen recording by triggering two separate sweeps, one for each DUT. If a two-pen X-Y recorder is available the comparison measurement can be recorded in a single sweep.

### WAVEGUIDE TRANSMISSION MEASUREMENTS

Transmission measurements in waveguide are performed in a similar manner to measurements in coax. Figure 48 shows an 8755 waveguide transmission system with coupling compensation that is capable of swept measurements in waveguide bands between 2.6 GHz and 18 GHz. The only major differences between



**Figure 48.** 8755 waveguide transmission systems using coupling compensation. Note that HP 281 Series waveguide-to-coax adapters are required to connect the 11664A detector to the waveguide directional couplers.

the system in Figure 48 and the corresponding coax system in Figure 39 are waveguide-to-coax adapters needed to connect the 11664A detectors to the waveguide system and the 10-dB coupling coefficients of the waveguide couplers.

Because 10-dB directional couplers are available in waveguide, the trade-off between coupling compensation and dynamic range is not as severe as it is in coax where coupling coefficients are usually 20 dB. However, a single waveguide coupler configuration similar to the coax setup in Figure 38 may be employed if sweeper power is not adequate to obtain the required dynamic range with coupling compensation. Since there is no common waveguide component with the same tracking characteristics as a coax power splitter, the waveguide transmission system with coupling compensation offers the best results for general measurements. Again, it should be reemphasized that the two couplers must be of the same design and manufacture to assure adequate tracking. The salient points in the Coax Transmission Summary apply equally well to waveguide.

With the physical similarities in the 8755 coax and waveguide transmission systems, it is not surprising that the theory of operation is identical. The setup, calibration, and measurement procedures for the waveguide system in Figure 48 are the same as those for the coax system in Figure 39.

The results of a typical waveguide measurement are shown in Figure 49. The X-Y recorder and grease-pencil techniques discussed in reference to 8755 coax-transmission systems all apply equally well to the waveguide system.

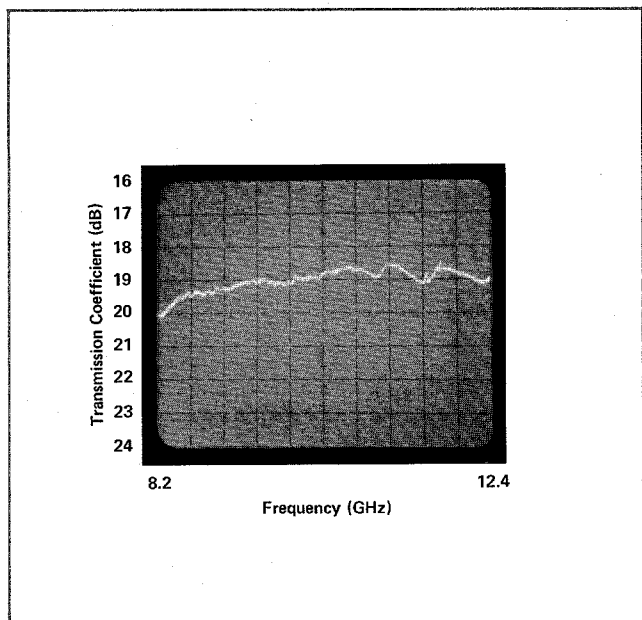


Figure 49. Insertion loss of a waveguide flap attenuator set for 20 dB of attenuation. The measurement was accomplished with the system in Figure 48.

## WAVEGUIDE TRANSMISSION MEASUREMENTS WITH RF SUBSTITUTION

An RF-substitution technique for measuring swept transmission coefficient in waveguide bands from 2.6 GHz to 40 GHz is shown in Figure 50<sup>4</sup>. System operation is based on a leveled sweeper and precision RF rotary-vane attenuator. Before the actual measurement is executed, specific values of attenuation or gain are pre-inserted via the attenuator, and the results stored in the form of calibration grids on the X-Y recorder. While RF substitution is not as convenient as the 8755 system, it does operate above 18 GHz and is composed of more economical instruments.

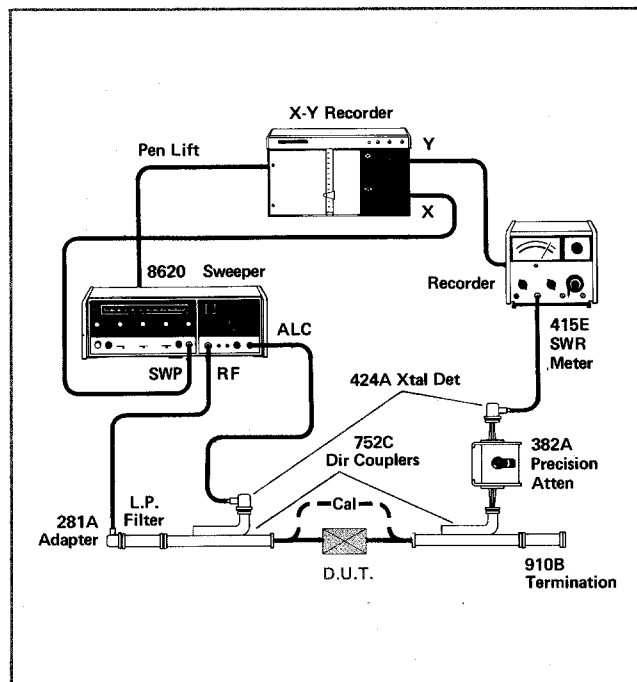
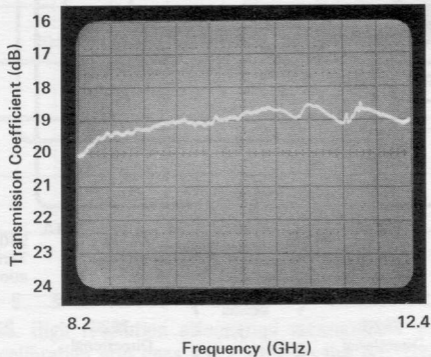


Figure 50. System for measuring transmission coefficient using RF substitution techniques. Similar to the RF-substitution reflectometer, specific values of attenuation (or gain) are pre-inserted and stored using precision attenuator. The DUT is then inserted and the measurement completed.

Obtaining the appropriate amount of leveled power from the sweeper is the first step in calibrating the system in Figure 50. Essentially, the sweeper is externally leveled in waveguide with a point-contact diode. Since the sweeper output is leveled, forward (or incident) power must remain constant both as a function of frequency and load impedance. Thus, it can be assumed that the incident power level will be the same in calibration and measurement. As noted in the discussion of 8755 transmission measurement systems, leveling accomplishes the same effect as ratioing. Operation of the 415E SWR meter requires that the sweeper output be amplitude modulated at a 1-kHz rate. 1-kHz amplitude modulation is available internally on all 8620 and 8690 Series sweepers.

<sup>4</sup> An 8690 Series sweeper must be used at frequencies above 18 GHz.



**Figure 49.** Insertion loss of a waveguide flap attenuator set for 20 dB of attenuation. The measurement was accomplished with the system in Figure 48.

With the DUT removed and the two couplers connected together, the 382A precision attenuator is used to pre-insert specific values of attenuation or gain. By manually triggering the sweeper for single sweeps, calibration grids are sequentially plotted for each setting of the precision attenuator. After the grids have been plotted, the attenuator is set to a specific reference level, and the DUT inserted. A final sweep is triggered and the transmission coefficient plotted on the X-Y recorder. If many similar devices are being tested, the grid lines, once plotted, may be used as an underlay for many measurements with the actual transmission coefficient plotted on translucent paper. However, the grid lines should be redrawn after long hours of testing or after the equipment has been turned off.

The results of typical measurement are exhibited in Figure 51. The RF-substitution system in Figure 50 is capable of attenuation measurements of 45 dB to 50 dB. Gain measurements over the same range may be accomplished in a straightforward fashion. Of course, gain measurements of greater than 50 dB are possible by adding another attenuator in the measurement arm.

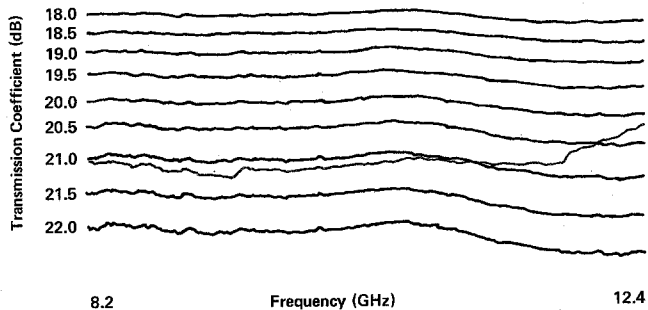


Figure 51. X-Y recording shows the transmission loss of a waveguide flap attenuator set for 20 dB of attenuation.

As in the coax systems, plotting calibration grids prior to measurement allows coupler and detector tracking (frequency response) errors to be eliminated from the calibration. In the RF-substitution system, calibration grids also free the system from reliance on the square-law performance of the readout detector. This occurs because each grid was plotted at a known level of RF attenuation or gain.

In RF-substitution measurements, the 415E acts solely as an amplifier for the Y-axis of the X-Y recorder. In this function it could be easily supplanted by a 432A or 435A power meter. It is also possible to incorporate an 8755 system into an RF-substitution measurement configuration, either as an amplifier or ratio-measuring instrument. If the 8755 system is employed as a ratio-measuring instrument, the sweeper leveling loop could be eliminated.

## TRANSMISSION MEASUREMENT ACCURACY

The primary sources of uncertainty in transmission measurements are mismatch and tracking errors. Tracking errors are essentially the result of differential frequency response and variations in the magnitude of  $\tau$ . Mismatch errors result any time there is a change in impedance in the system, such as a connector interface.

Interconnection of two impedances different from the system characteristic impedance ( $Z_0$ ) results in mismatch uncertainty like that illustrated in Figure 52. A portion of the incident signal is reflected by the detector,  $\rho_d$ , becoming an incident signal on the source impedance. Consequently, part of this signal is reflected by the source,  $\rho_s$ , resulting in the worst-case mismatch error of  $1 \pm \rho_s \rho_d$ .

The mismatch uncertainty may be quantified using the HP Mismatch Error Limits Calculator<sup>5</sup> in Figure 53; the Mismatch Calculator is on the reverse side of the Reflectometer Calculator discussed in the reflectometer error section.

<sup>5</sup> A complimentary HP Reflectometer/Mismatch Error Limits Calculator is available from any Hewlett-Packard sales office.

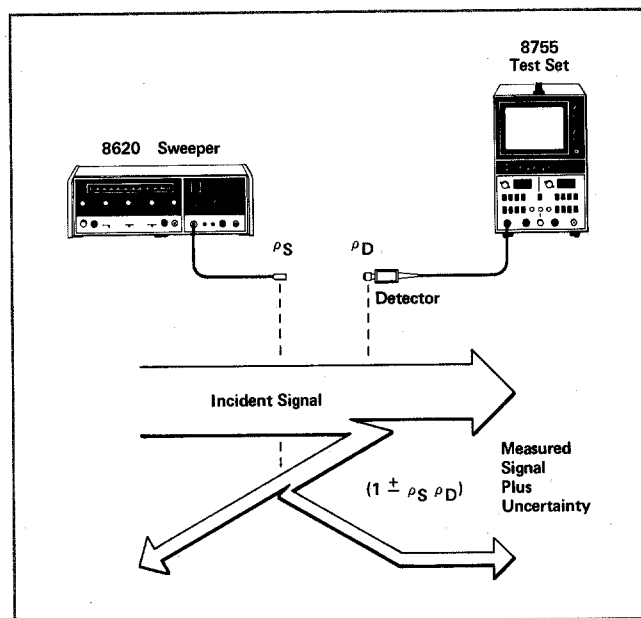


Figure 52. Schematic representation of mismatch uncertainty. A portion of the incident signal is reflected by the detector and then rereflected by source, generating the resulting uncertainty  $(1 \pm \rho_s \rho_d)$ .

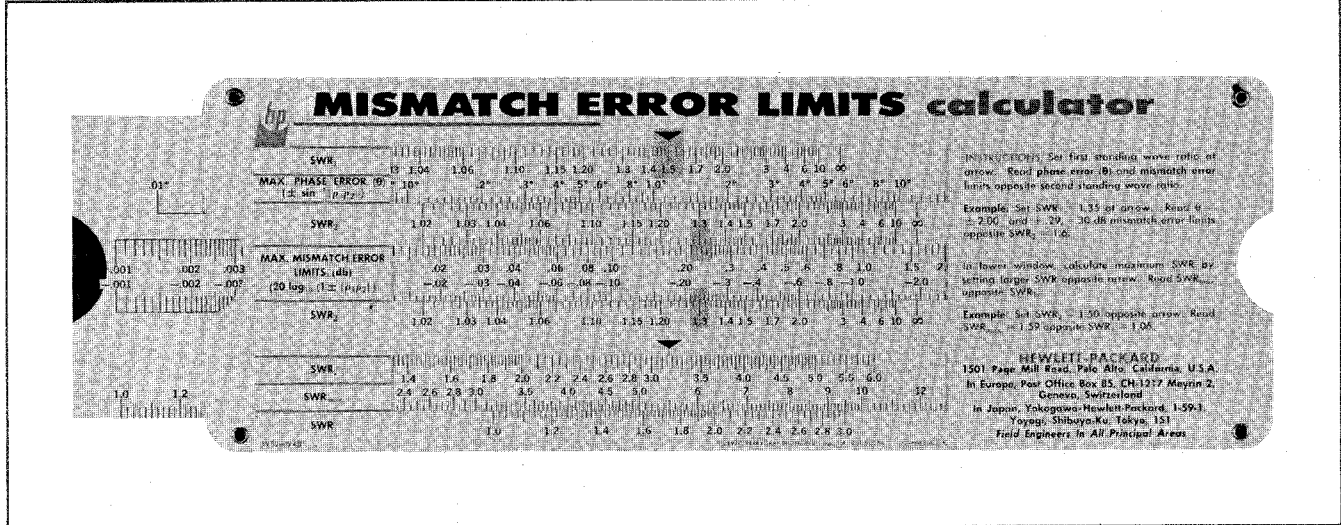


Figure 53. HP Mismatch Error Limits Calculator is used for computing the worst-case uncertainties resulting from the interface of two impedances different from the system characteristic impedance.

For instance, the SWR<sub>1</sub> scale is adjusted so that 1.5 is under the black arrow. The MAX. MISMATCH ERROR LIMITS (dB) are indicated below and above the two SWR<sub>2</sub> scales. For a SWR<sub>2</sub> = 1.3, the two limits of uncertainty are +0.225 dB and -0.23 dB; this would be the maximum or worst-case calibration uncertainty that would result from interfacing a source of 1.5 SWR with a detector of 1.3 SWR. Insertion of the DUT into the measurement system results in additional mismatch uncertainty between the source and the DUT input port and the detector and the DUT output port. A detailed mismatch error analysis is presented in Appendix C.

Uncertainty resulting from source mismatch is reduced by leveling the sweeper or making ratio measurements (typically 1.1 to 1.3 SWR). In a similar manner, detector mismatch may be reduced by isolation with a pad or directional coupler (typically <1.2 SWR for a pad and <1.3 SWR for a coupler).

Tracking errors resulting from differential frequency response of the measurement system can be minimized by making a grease-pencil recording of the calibration trace and subtracting the frequency response from subsequent measurements. The magnitude of tracking errors resulting from ratio measurement inaccuracies (variations with  $\tau$ ) is usually obtained from the appropriate technical data. Appendix C offers further discussion of tracking errors.

### SIMULTANEOUS TRANSMISSION/REFLECTION MEASUREMENTS

In aligning broadband networks, it is often necessary to compromise between transmission coefficient and reflection coefficient. However, equipment limita-

tions can require that these two parameters be measured separately, making it difficult to observe the mutual interaction between the parameters. CRT photos of simultaneous transmission coefficient/return loss measurements made with the 8755 system are shown in Figure 54. The ability to make simultaneous measurements with real-time observation of the trade-offs between the transmission coefficient flatness and SWR is a powerful tool for network optimization.

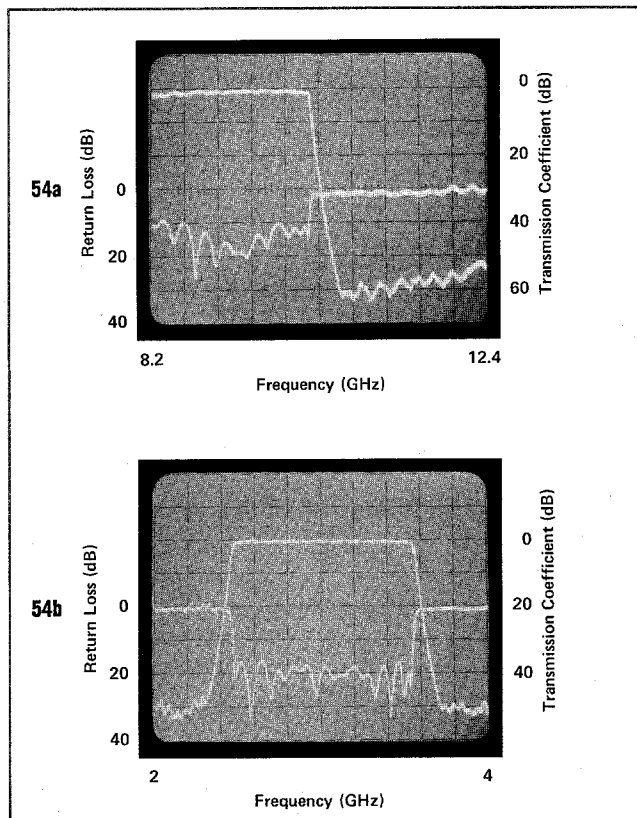
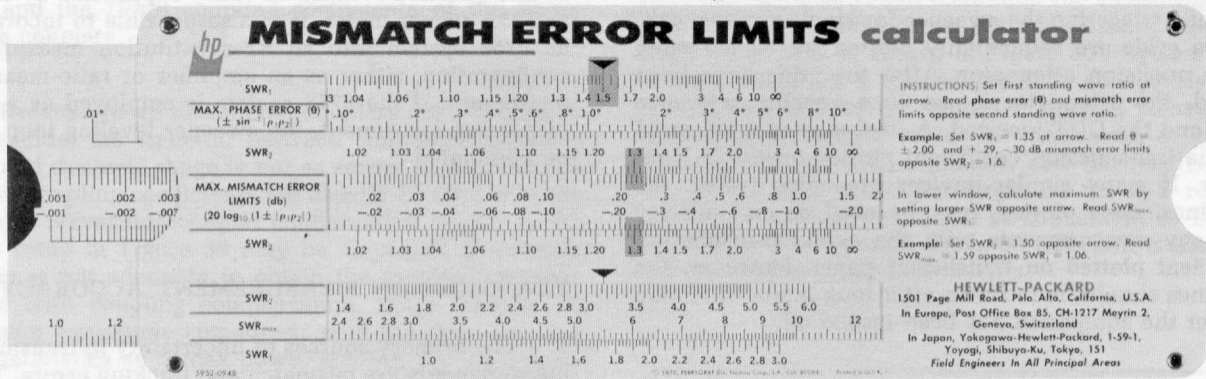


Figure 54. Simultaneous measurement of return loss and transmission coefficient of a) low-pass filter (10 GHz) and b) bandpass filter (2.5 to 3.5 GHz) using an 8755 system.



INSTRUCTIONS: Set first standing wave ratio at arrow. Read phase error (θ) and mismatch error limits opposite second standing wave ratio.

Example: Set SWR<sub>1</sub> = 1.35 at arrow. Read θ = ± 2.00° and + 29, -30 dB mismatch error limits opposite SWR<sub>2</sub> = 1.6.

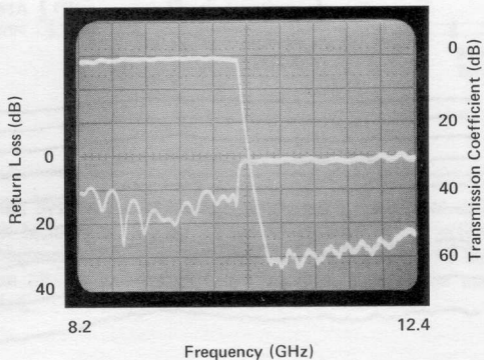
In lower window, calculate maximum SWR by setting larger SWR opposite arrow. Read SWR<sub>max</sub> opposite SWR<sub>1</sub>.

Example: Set SWR<sub>2</sub> = 1.50 opposite arrow. Read SWR<sub>max</sub> = 1.59 opposite SWR<sub>1</sub> = 1.06.

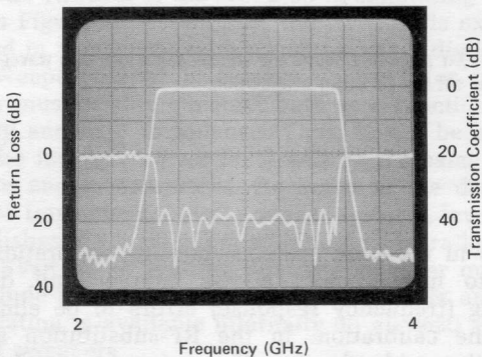
**HEWLETT-PACKARD**  
 1501 Page Mill Road, Palo Alto, California, U.S.A.  
 In Europe, Post Office Box 85, CH-1217 Meyrin 2, Geneva, Switzerland  
 In Japan, Yokogawa-Hewlett-Packard, 1-59-1, Yoyogi, Shibuya-Ku, Tokyo, 151  
 Field Engineers In All Principal Areas

Figure 53. HP Mismatch Error Limits Calculator is used for computing the worst-case uncertainties resulting from the interface of two impedances different from the system characteristic impedance.

54a



54b



**Figure 54.** Simultaneous measurement of return loss and transmission coefficient of a) low-pass filter (10 GHz) and b) bandpass filter (2.5 to 3.5 GHz) using an 8755 system.

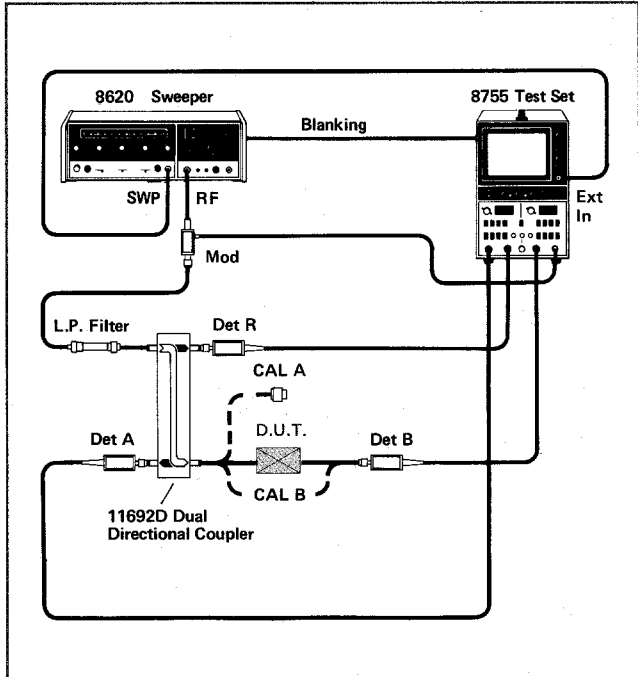


Figure 55. System for simultaneous measurement of return loss and transmission coefficient using a single 11692D (2 to 18 GHz) dual directional coupler.

Two measurement setups for making simultaneous return loss/transmission coefficient measurements are shown in Figures 55 and 56. Similarly to the comparison measurement, the R detector samples the incident signal and is common to both measurements. The A detector samples the reflected signal as the B detector concurrently samples the transmitted signal. Both setups incorporate the basic coax reflectometer system while coupling compensation in transmission measurements is offered by the system in Figure 56. The setup in Figure 55 is essentially the single coupler transmission measurement with no compensation for the coupling variation seen at the R detector. Hence, the choice of setups is purely a function of the type of transmission data required. The criteria for the choice are the trade-offs between dynamic range and compensation for coupling variation with frequency; these trade-offs are discussed in the transmission measurement summary.

Another setup for making simultaneous measurements using the 11666A reflectometer bridge is shown in Figure 57. It is also possible to use a hybrid combination of a power splitter and a directional coupler for simultaneous measurements. While the bridge is convenient because of its broad frequency range and built in detectors, the dynamic range of transmission measurements suffers because of its high main arm loss [9 dB]. Also, no complementary tracking relationships (like those in Figure 56) exist when either the bridge or the power-splitter coupler combination are employed. However, tracking errors are negligible compared to

<sup>6</sup> High-directivity (some >40 dB), single-octave, coax-directional couplers are available from manufacturers such as Narda and Wavecom.

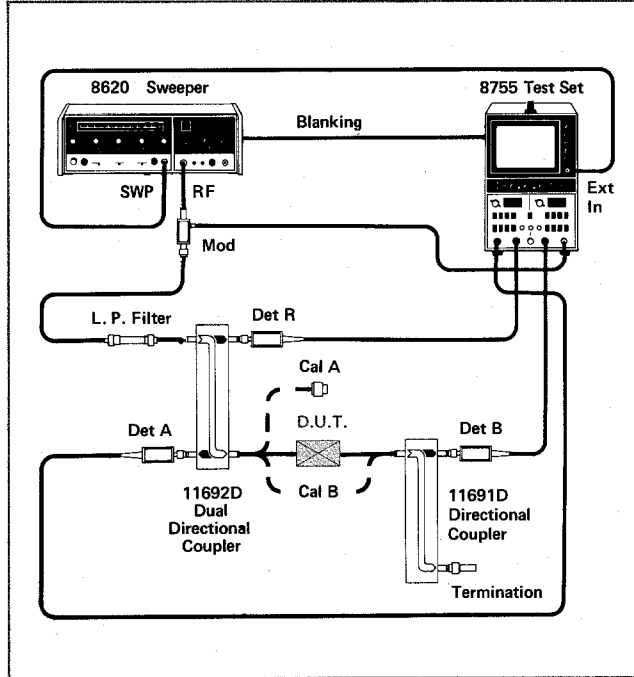


Figure 56. Simultaneous measurement employing an 11691D (2 to 18 GHz) directional coupler for coupling compensation.

directivity errors in high-return loss measurements. Directivity errors may be reduced by employing a high directivity, narrow-band, coax directional coupler.<sup>6</sup>

The actual measurement involves calibration of one channel of the 8755 system for return loss measurement and the other channel for transmission coefficient; the DUT is inserted and the measurement completed. In the systems shown in Figures 55 through 57, the A channel is calibrated for a reflectometer measurement like the setups in Figure 21, and the B channel is calibrated for transmission measurement like the setup in Figure 38. After the DUT is inserted both traces may be displayed simultaneously with the A channel controlling the return-loss trace and the B channel controlling the transmission trace.

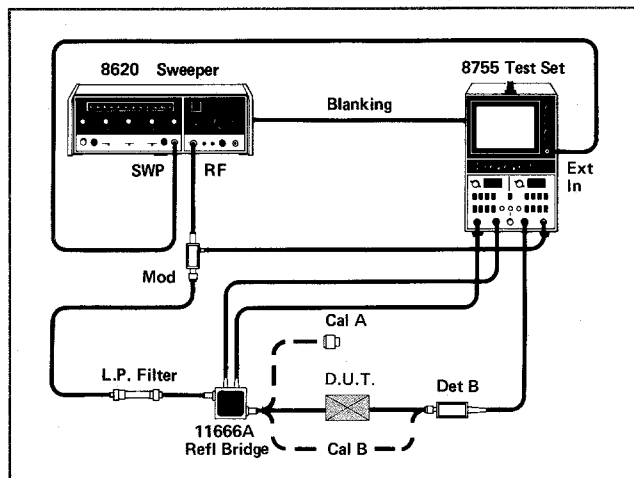


Figure 57. Simultaneous measurements using the 11666A reflectometer bridge (40 MHz to 18 GHz).

Since the two measurements and the two measurement channels of the 8755 are virtually independent, any of the previous techniques, such as grease-pencil and X-Y recordings, may be applied. Throughout this application note, Channel A of the 8755 system has been arbitrarily utilized for reflection measurements, while Channel B has been used for transmission measurements. Except for the common use of the R detector both channels are independent and may be used to make any two measurements of the user's choice.

## POWER MEASUREMENTS

Knowledge of absolute power in milliwatts or dBm is necessary when network parameters vary as a function of the input-signal power level. The power level at a selected point in a swept measurement configuration may be measured using the system in Figure 58. The HP 432 Series power meter with appropriate thermistor detectors measures absolute power between 10 mW and 1  $\mu$ W over a 1 MHz to 40 GHz frequency range. Measurements in 1 MHz to 18 GHz range are possible in coax while waveguide measurements are made between 2.6 and 40 GHz. Similarly, the HP 435A and 436A power meters and the appropriate thermocouple detector measure power levels in coax between 3 W and 0.3  $\mu$ W at frequencies ranging from 100 kHz to 18 GHz.

After the appropriate power meter has been calibrated, system calibration may be established by varying the power incident on the detector and noting the corresponding variation on the X-Y recorder. This is accomplished at a CW frequency, using the X-axis

GAIN control to draw grid lines if required. Once the X-Y recorder has been calibrated, the detector may be connected to the point of measurement and a single measurement sweep triggered. The sweep time should be long enough (at least 20 to 40 sec/octave) for the detector to respond to all variations in power. Thermocouple detectors have particularly long response times when power levels under 300  $\mu$ W are measured.

An 8755 system like the one in Figure 59 may also be utilized for swept measurements of absolute power in coax. POSITION controls are used to establish a convenient graticule as a 0 dBm reference and the system is calibrated to readout absolute power from +10 dBm (10 mW) to -50 dBm (10 nW) over the 15 MHz to 18 GHz frequency range. If the OFFSET CAL is set to OFF, the display is automatically calibrated in absolute power with respect to the 0 dBm reference graticule. The sweeper may be adjusted for a continuous CRT display during measurement, and the OFFSET dB thumbwheels and RESOLUTION push buttons may be used to obtain the desired display. X-Y recordings may be obtained in a normal fashion utilizing the 8755 system's auxiliary outputs.

Power can be measured at any of the 8755 system's three detector inputs, and the response of any two of these detectors displayed simultaneously. While the 8755 is sensitive to low levels of absolute power and has fast response time, it is not as accurate as the 432 Series and 435A power meters primarily because of its poorer detector match (see discussion of power measurement accuracy) and the modulator loss.

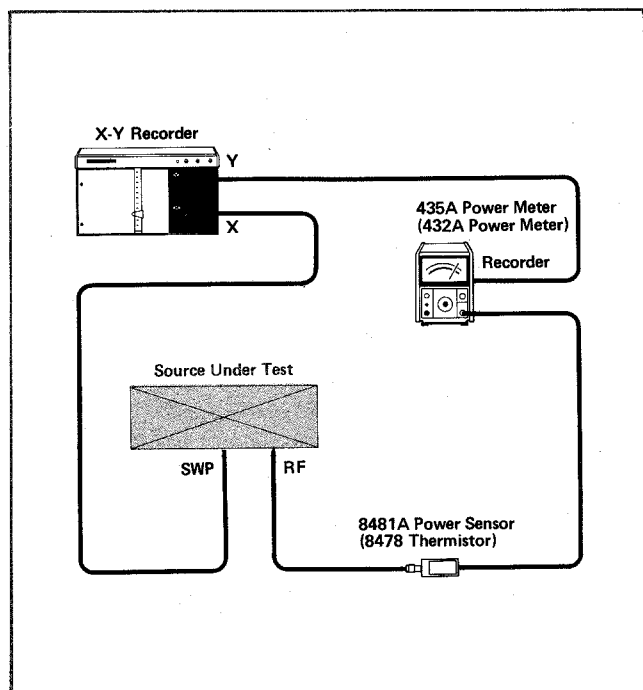


Figure 58. System for swept measurement of absolute power using either the 435A power meter (or 432 series).

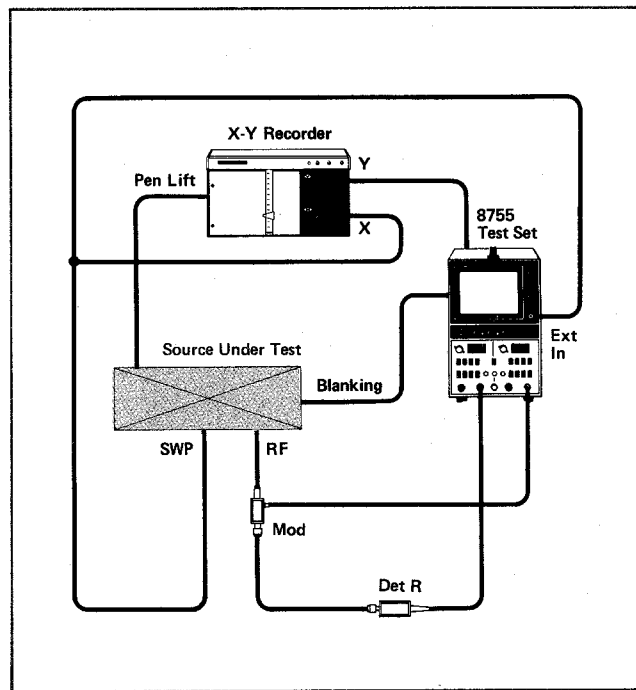
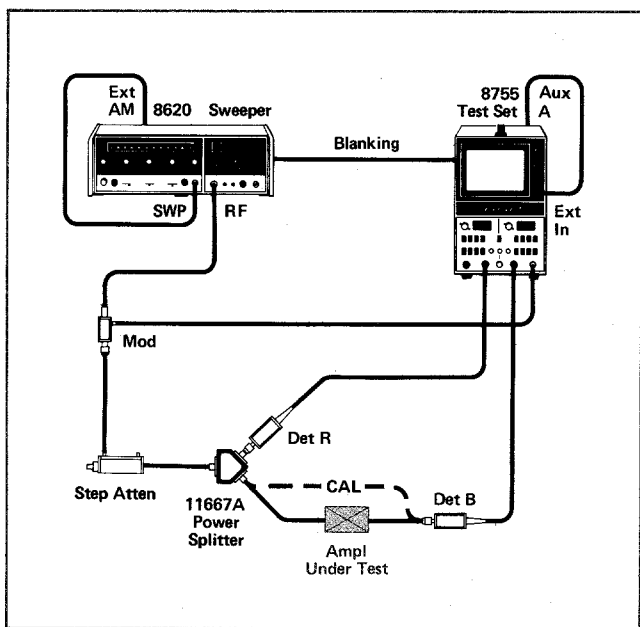


Figure 59. Configuration for measuring swept absolute power using the 8755 system.

## INPUT POWER VS. OUTPUT POWER OR GAIN

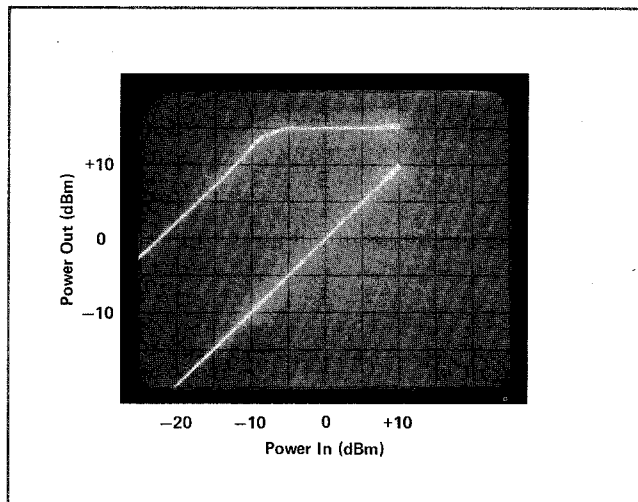
A system for measuring output power or gain as a function of input power at a fixed frequency is shown in Figure 60. The system is particularly useful for determining the saturation or compression point of amplifiers. In the system of Figure 60, the incident power level is swept over approximately a 30-dB range by amplitude modulating the 8620 sweeper output with its own sweep voltage. The maximum incident power level can be further manipulated using the step attenuator. Using the auxiliary outputs of the 8755 system to provide a voltage proportional to the incident power measured at the R detector, the horizontal axis of the CRT may be calibrated for absolute input power. The vertical axis may be calibrated for absolute output power by displaying the signal at the B detector or for gain by performing the ratio B/R. Measurement is accomplished by inserting the DUT between the power splitter's output arm and the B detector.



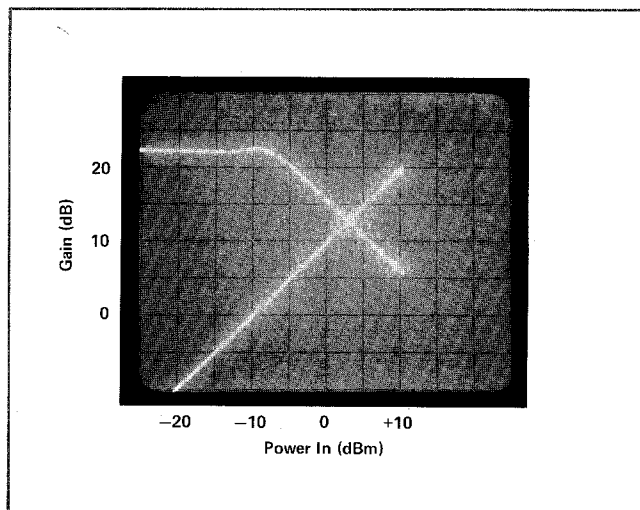
**Figure 60.** System for measuring input power vs. output power or input power vs. gain. The input power is swept using the 8620's sweep ramp to drive its internal PIN attenuator. The horizontal axis of the 8755 system is calibrated in absolute power by driving the horizontal input with the auxiliary output proportional to the signal seen at the R detector.

Because some sweepers do not have internal PIN modulators and others are always internally leveled (usually at frequencies <1 GHz), it may not be possible to sweep output power using the EXT AM input. In these situations, an external modulator may be used to sweep power. The sweeper ramp (0-10 V for 8620 and 0-15 V for 8690 sweepers) may be used to drive the external modulator, provided compatibility exists.

The results of input power vs. output power and an input power vs. gain measurements are shown in Figures 61 and 62 respectively. Note that diagonal trace representing the power sweep is always present on the display. Using the OFFSET dB thumbwheels and OFFSET CAL vernier it is possible to measure parameters like the 1 dB compression point.



**Figure 61.** Input power vs. output power for an amplifier at 1 GHz. Output power increases linearly with input power until the input reaches  $-8$  dBm. Note that the diagonal trace or the input power seen at the R detector must be displayed in order to obtain horizontal deflection on the screen.

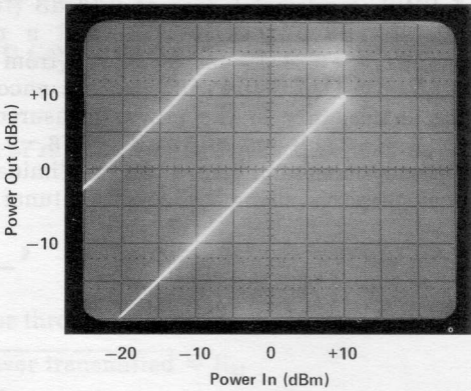


**Figure 62.** Input power vs. gain for an amplifier at 1 GHz. Gain remains constant (22 dB) with input power until the input reaches  $-8$  dBm and saturation occurs. The diagonal trace must be displayed as it was in Figure 61.

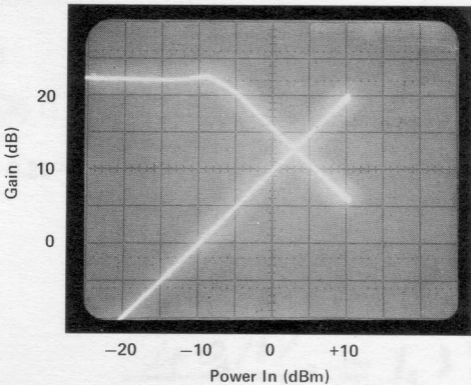
## POWER MEASUREMENT ACCURACY

The primary sources of inaccuracy in measurements of absolute power are source-detector mismatch, detector frequency response, and instrument or display errors. Mismatch errors are by far the most serious uncertainty.

A portion of the power incident on a detector from a  $Z_0$  transmission line will be reflected and lost. For any particular detector reflection coefficient, this MISMATCH LOSS (dB) may be calculated using the HP REFLECTOMETER CALCULATOR. Similarly, a portion of the reflected power will be re-reflected by the source (provided it is not reflectionless), adding an uncertainty to the total mismatch loss. A HP MISMATCH ERROR LIMITS CALCULATOR may be used to determine the uncertainty limits.



**Figure 61.** Input power vs. output power for an amplifier at 1 GHz. Output power increases linearly with input power until the input reaches  $-8$  dBm. Note that the diagonal trace or the input power seen at the R detector must be displayed in order to obtain horizontal deflection on the screen.



**Figure 62.** Input power vs. gain for an amplifier at 1 GHz. Gain remains constant (22 dB) with input power until the input reaches  $-8$  dBm and saturation occurs. The diagonal trace must be displayed as it was in Figure 61.

For example, when measuring the  $Z_0$  power from a sweeper which has a source SWR of 1.5 with a detector of 1.5 SWR, a mismatch loss of 0.18 dB (from the REFLECTOMETER CALCULATOR) and a mismatch uncertainty of +0.34 dB and -0.36 dB (from the MISMATCH LIMITS CALCULATOR) will be encountered. The net uncertainty in the power measured is +0.18 dB [-0.18 -(-0.36)] and -0.52 dB (-0.18 -0.34). At a CW frequency mismatch errors can be eliminated for all practical purposes, using a slide-screw tuner.

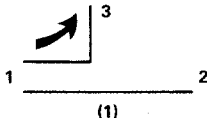
Detector frequency response and display or instrumentation errors are provided with the technical data on most power meters and similar equipment. All Hewlett-Packard instruments measuring absolute power are National Bureau of Standards traceable. The uncertainty in this tracing process is often added as part of the worst-case measurement error.

# APPENDIX A

## SOURCE MATCH OF LEVELED OR RATIO SYSTEMS AND COUPLER VS. 2- and 3-RESISTOR SPLITTERS

### COUPLERS:

The effective source reflection coefficient of a coupler-leveled or ratio system has been shown<sup>7</sup> to be  $\Gamma_s = \Gamma_c \ddagger TD$



Where  $\Gamma_c$  = output reflection coefficient of couplers main or through arm =  $S_{22}$

T = transmission coefficient of through arm =  $\sqrt{\text{power transmitted}} = S_{21}$

e.g., 10-dB coupler  $\cong 0.95$

20-dB coupler  $\cong 0.995$

D = Directivity =  $\frac{S_{32} \text{ (isolation)}}{S_{31} \text{ (coupling)}}$

The above is a vector equation. Since the techniques described do not derive phase information, the maximum source match can be calculated by adding terms of the equation assuming worst-case vector addition.

### EXAMPLES:

HP 11692D Broadband 2 to 18-GHz coupler at 18 GHz is specified:

1. 1.4 main line SWR = 0.167 reflection coefficient
2. 20-dB coupling = 0.995 transmission coefficient
3. 26-dB directivity = 0.05

$$\begin{aligned} \text{Maximum Source Match} &= 0.167 + 0.995 \times 0.05 = 0.217 (\rho) \\ &= 1.55 \text{ SWR} \end{aligned}$$

@ 8 GHz specs are:

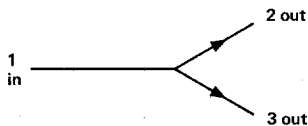
1. 1.3 SWR
2. 20-dB coupling
3. 30-dB directivity

$$\begin{aligned} \text{Maximum Source Match} &= 0.131 + 0.995 \times 0.03 = 0.164 \\ @ 8 \text{ GHz} &= 1.39 \text{ SWR} \end{aligned}$$

The above solutions do represent absolute worst cases but are usually modified somewhat. The through line mismatch of a coaxial coupler is largely due to the effects of both input and output connectors. Since the input connector is within the loop and its effects thus removed, some recommend including only 50 to 70% of the specified through line match.

### POWER SPLITTERS:

Using similar flow-graph techniques the effective source match of a power splitter on either arm EQUALS



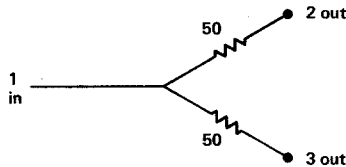
$$\begin{aligned} \Gamma_s &= S_{22} - S_{21} \times \frac{S_{32}}{S_{31}} \quad \text{or} \\ &= S_{33} - S_{31} \times \frac{S_{23}}{S_{21}} \end{aligned}$$

or = output reflection coef - tracking x directivity (equivalent to the equation for couplers).

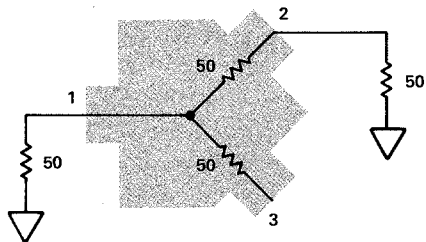
<sup>7</sup> Paul C. Ely, Jr., "Swept Frequency Techniques," Proc. of the IEEE vol. 55 #6 June, 1967.

## TWO-RESISTOR SPLITTER:

For the HP 11667A, a 2 resistor  $50\ \Omega$  configuration is employed



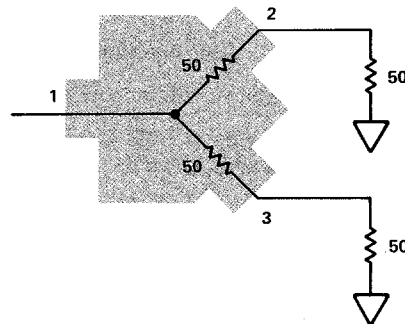
First, let's calculate  $S_{33}$ : the equivalent resistance in a  $50\ \Omega$  reference s-parameter measurement is



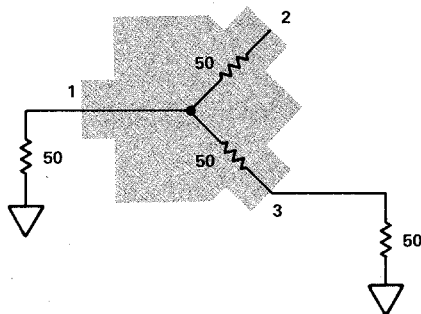
$$R = 50 + \frac{50 \times 100}{50 + 100} = 83.33\ \Omega$$

$$S_{33} = \frac{R - Z_0}{R + Z_0} = \frac{33.33}{133.33} = .25$$

$$S_{22} = S_{33}$$



$$S_{21} = S_{31} = .5$$



$$S_{23} = S_{32} = .25$$

$$\text{APPLYING EQ (2)} \quad \Gamma_s = .25 - .5 \times \frac{.25}{.5} = 0$$

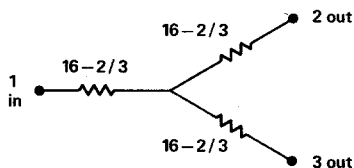
Since all elements are resistive, phase angles are zero and perfect cancellation occurs in the ideal case. Actual equivalent source match is specified as:

- <1.20 SWR at 8 GHz
- <1.33 SWR at 18 GHz

due mainly to connector imperfections.

## THREE-RESISTOR SPLITTER:

The conventional three-resistor splitter is configured:



$$\text{At any port equivalent input } R = 16\frac{2}{3} + \frac{16\frac{2}{3} + 50}{2} = 50\ \Omega$$

$$S_{22} = S_{33} = S_{11} = 0$$

$$S_{12} = S_{21} = S_{13} = S_{31} = S_{32} = S_{23} = 0.5$$

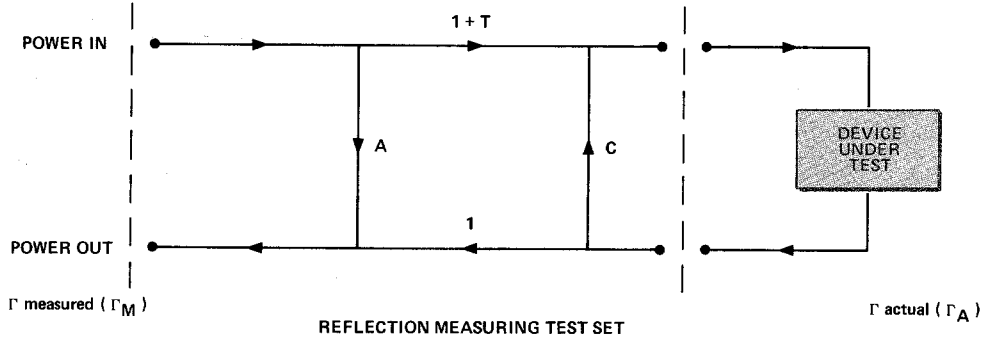
$$\text{Again applying Equation (2)} : \Gamma_s = 0 - 0.5 \times \frac{0.5}{0.5} = 0.5$$

A  $\Gamma_s$  of 0.5 is an equivalent source SWR of 3:1. A 3:1 source SWR will cause a 1 dB ripple when measuring a device with a 1.25 input SWR. Thus, the three-resistor power splitter should never be used in leveling or ratio applications.

# APPENDIX B

## ERRORS IN REFLECTION MEASUREMENTS

Any reflection measuring system can be represented by:



A represents power leaked directly from the input terminal of the test set to its output, independent of the device under test. Directivity in the coupler is the major contributor in a practical test set.

T represents the system scaling factor. The coupling of the test set and the detector and display sensitivities are the major contributors to the scaling factor.

C represents the source match or the equivalent reflection looking back into the test coupler as developed in Appendix "A."

By application of Mason's non-touching loop law, it can be shown:

$$\Gamma_m = A + \frac{(1 + T)\Gamma_A}{1 - C\Gamma_A} \quad (1)$$

This is vector relationship, i.e., all  $\Gamma$ 's, A, T, and C are complex quantities. Since phase-measuring devices are beyond the scope of this note, we will employ this formula only to relate practical coupler and test set parameters to the maximum errors than can be expected by assuming worst-case vector addition of all terms.

$$\therefore \text{Max error} = E = \Gamma_m - \Gamma_A$$

$$E = A + \frac{(1 + T)\Gamma_A}{1 - C\Gamma_A} - \Gamma_A$$

$$= A + (1 + T)\Gamma_A (1 + C\Gamma_A + C^2\Gamma_A^2 + C^3\Gamma_A^3 + \dots) - \Gamma_A$$

ignoring the higher order terms,  $C^2\Gamma_A^2 + C^3\Gamma_A^3 + \dots$

$$\cong A + (1 + T)\Gamma_A (1 + C\Gamma_A) - \Gamma_A$$

$$= A + T\Gamma_A + C\Gamma_A^2 + TC\Gamma_A^2$$

the term  $TC\Gamma_A^2$  is negligible since T and C are both small

$$\cong A + T\Gamma_A + C\Gamma_A^2 \quad (2)$$

Since T is not known, both a calibration standard (short circuit) and the unknown are measured when a reflectometer is employed, and it is necessary to apply equation (2) to both conditions:

$$\Gamma_{SH} = \Gamma_A + (A + T\Gamma_A + C\Gamma_A^2)$$

$$= -1 + (A - T + C)$$

where  $\Gamma_A = -1$  for short circuit (standard)

$$\Gamma_{UNKNOWN} = \Gamma_A + (A + T\Gamma_A + C\Gamma_A^2)$$

where  $\Gamma_A$  = the actual reflection coefficient of the unknown.

The measurement is performed by taking the ratio of  $\Gamma_{\text{UNKNOWN}}$  and  $\Gamma_{\text{SH}}$  (or the difference in dB, if the two quantities are measured in return loss).

$$\Gamma_{\text{DISPLAYED}} = \frac{\Gamma_{\text{UNKNOWN}}}{-\Gamma_{\text{SH}}} = \frac{\Gamma_A + A + T\Gamma_A + C\Gamma_A^2}{1 - (A - T + C)} \quad (3)$$

$$= [\Gamma_A + A + T\Gamma_A + C\Gamma_A^2] [1 + (A - T + C) + (A - T + C)^2 + \dots]$$

$$\cong [\Gamma_A + A + T\Gamma_A + C\Gamma_A^2] [1 + A - T + C]$$

$$= \Gamma_A + A + T\Gamma_A + C\Gamma_A^2$$

$$+ A[\Gamma_A + A + T\Gamma_A + C\Gamma_A^2]$$

$$- T[\Gamma_A + A + T\Gamma_A + C\Gamma_A^2]$$

$$+ C[\Gamma_A + A + T\Gamma_A + C\Gamma_A^2]$$

eliminating higher order terms

$$\cong \Gamma_A + [A + (T + A - T + C)\Gamma_A + C\Gamma_A^2] \quad (4)$$

$$= \Gamma_A + [A + (A + C)\Gamma_A + C\Gamma_A^2] \quad (5)$$

$$\text{thus the uncertainty in } \Gamma_{\text{DISPLAYED}} - \Gamma_A = \Delta\Gamma = A + (A+C)\Gamma_A + C\Gamma_A^2 \quad (6)$$

$$= A + B\Gamma_A + C\Gamma_A^2$$

where  $B = A + C = \text{CALIBRATION ERROR}$

By replacing  $\Gamma$  with its scalar equivalent,  $\rho$ , it is possible to obtain equation (5) on page 18:

$$\Delta\rho = A + B\rho + C\rho^2$$

## Discussion

The B term or calibration error is the error due to directivity (A) and source match (B) that occurs when the reflectometer is calibrated with the short circuit. This error may be removed for all practical purposes by the open — short calibration discussed on page 16.

Studying equation (4), it should be noted that the system scaling factor T cancels out of the uncertainty equation. However, a caution is in order. If instrumentation errors (detector and display) cause T to change as a function of amplitude, cancellation does not occur. Also, if T varies with frequency and a display graticule is used as the calibration reference in a swept measurement, frequency response errors will enter into the B term. A grease pencil or other storage technique may be utilized to store the exact calibration, eliminating frequency response errors.

### EXAMPLE:

$B = 0$  where calibration error has been removed with an open — short calibration and frequency response removed with a grease pencil.

With a 11692D coupler at 8 GHz.

Minimum directivity = 26 dB =  $A = 0.05$  and from Appendix "A" effective source reflection =  $C = 0.164$ .

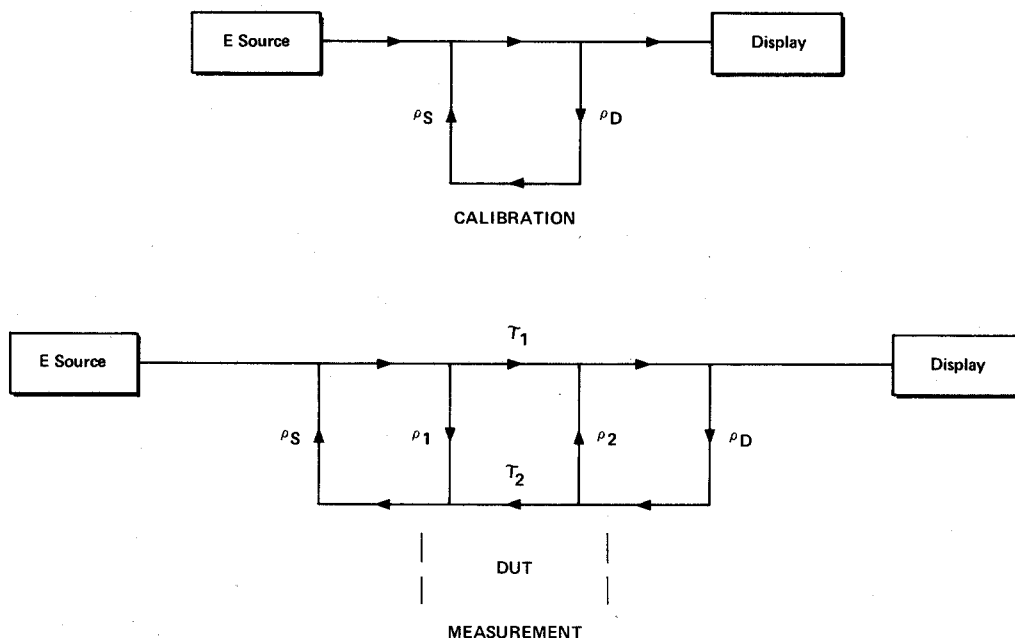
$$\therefore E = 0.05 + 0.164\Gamma_A^2$$

Thus directivity errors dominate the measurement of low SWR devices while source match and tracking terms overshadow the measurement of high reflections. Instrument errors may be determined from appropriate technical specifications.

# APPENDIX C

## ERRORS IN TRANSMISSION MEASUREMENTS

The mismatch error terms in a transmission measurement system can be represented by the following flow graphs:



$\rho_S$  and  $\rho_D$  represent the effective source and detector reflection coefficients, respectively.

$\rho_1$  and  $\rho_2$  represent the input and output reflection coefficients of the DUT, respectively.

$\tau_1$  and  $\tau_2$  are the forward and reverse transmission coefficients of the DUT, respectively.

By the application of Mason's non-touching loop law, it can be shown the mismatch uncertainty in the measurement of the forward transmission coefficient,  $\tau_1$ , is:

$$\text{Mismatch Uncertainty} = \frac{(1 \pm \rho_S \rho_D)}{(1 \pm \rho_S \rho_1) (1 \pm \rho_2 \rho_D) \pm (\rho_S \tau_1 \tau_2 \rho_D)} \quad (1)$$

The numerator is the calibration uncertainty represented by the first flow graph while the terms in the denominator are a result of the DUT insertion. The term  $(\rho_S \tau_1 \tau_2 \rho_D)$  may be ignored if  $\tau_1 \tau_2 > 10$  dB. All of the terms in equation 1 are complex quantities, i.e., they have both magnitude and phase. Because phase is not known, plus and minus signs are inserted so that the worst-case errors resulting from the vectorial additions will be obtained.

The HP MISMATCH ERROR LIMITS CALCULATOR is ideally suited for evaluating the terms in equation number 1. Consider a case where:

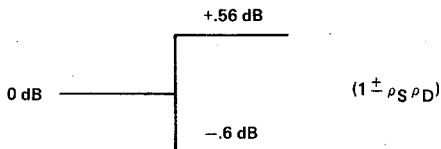
$$\rho_S = 0.33 \text{ (SWR} = 2\text{), typical for unlevelled sources.}$$

$$\rho_D = 0.2 \text{ (SWR} = 1.5\text{), typical for most diode detectors without pads.}$$

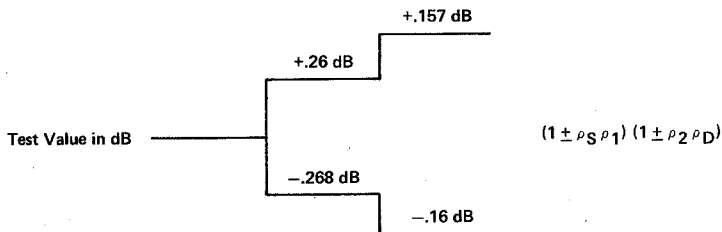
$$\rho_1 \rho_2 = 0.09 \text{ (SWR} = 1.2\text{)}$$

$$\tau_1 \tau_2 = 10 \text{ dB of loss.}$$

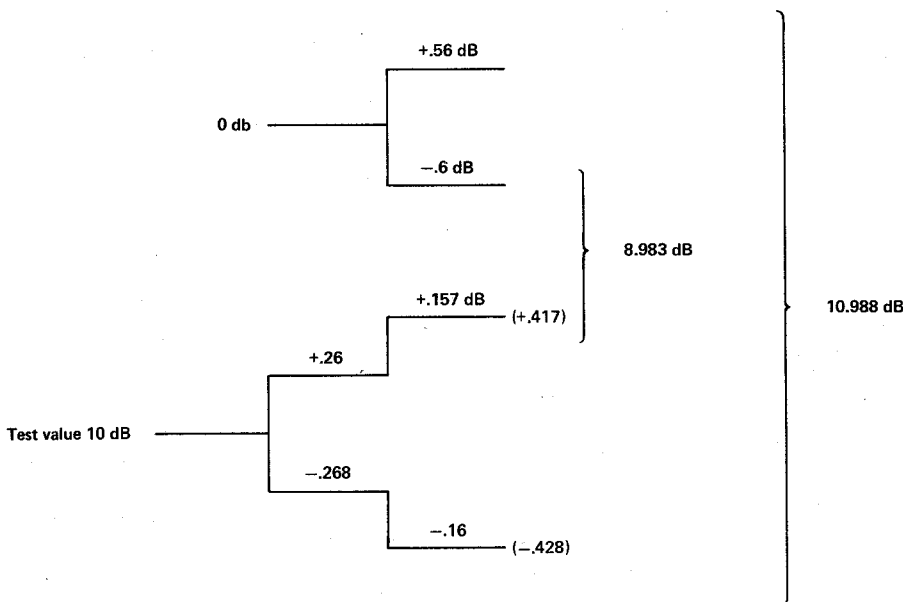
Using the calculator, the calibration uncertainty can be determined by setting the  $SWR_1$  to 2.0 and reading the MAX. MISMATCH ERROR LIMITS (dB) above and below 1.5 on the two  $SWR_2$  scales. In this case, the limits are +0.56 dB and -0.6 dB may be graphically represented:



In a similar fashion, the measurement terms may be evaluated. The limits are +0.26 dB -0.268 dB for  $(1 \pm \rho_s \rho_1)$ , while they are +0.157 and -0.16 for  $(1 \pm \rho_2 \rho_D)$ . Graphically this is represented as follows:



A composite of the calibration and measurement uncertainties can now be obtained:



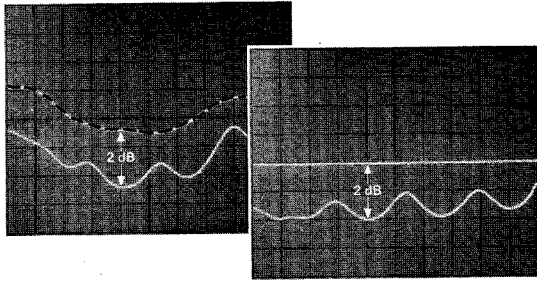
For a 10-dB loss measurement, total mismatch uncertainty causes a -1.017 dB and +0.988 dB uncertainty. If  $\tau_1$  and  $\tau_2$  were less than 6 dB, the  $\pm(\rho_s \tau_1 \tau_2 \rho_D)$  term would have added further uncertainty to the measurement. It should be noted that these are the worst-case errors; typical mismatch errors are much less than worst-case.

Source match can be improved to a SWR between 1.1 and 1.3 either by leveling the sweeper or making a ratio measurement (see Appendix "A"). The detector match may be improved to SWR of  $\leq 1.2$  by introducing a 10-dB pad between the detector and the DUT; if the coupling compensation techniques are used the effective detector SWR is approximately 1.3 or the mainline SWR of the coupler. Reworking the previous example with  $\rho_s = 1.1$  and  $\rho_D = 1.2$ , the worst-case mismatch uncertainty is reduced to -0.14567 and +0.1473.

$$\text{Transmission Uncertainty} = \frac{(1 \pm \rho_s \rho_D)}{(1 \pm \rho_s \rho_1) (1 \pm \rho_2 \rho_D) \pm (\rho_s \tau_1 \tau_2 \rho_D)} + \text{TRACKING ERRORS} \quad (2)$$

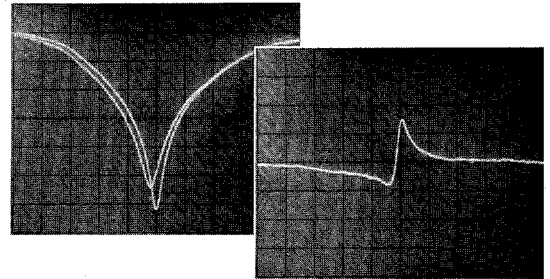
$\underbrace{\hspace{10em}}_{\text{Low Loss}}$

After the mismatch uncertainty has been evaluated, only tracking errors remain. The portion of tracking errors caused by differential frequency response is usually specified for measurement systems like the HP 8755 system. However, most of this error can be eliminated, using a grease-pencil recording of the calibration trace. Tracking errors caused by variations in  $\tau$  are also specified for most detector/display systems like the HP 8755 system. There is no practical way to eliminate the tracking error caused by variation in  $\tau$  in a ratio measurement.



System frequency response variations (dotted line above) are easily removed.

Digital storage is a method for obtaining flicker free displays at slow sweep speeds. An even, clear, and continuous trace can always be produced regardless of sweep rate. Normalization removes the effects of system frequency response and provides for simplified comparison measurements. Grease pencil reference lines or visual interpolation are not needed, since the resulting CRT image is an accurate graph of amplitude versus frequency.



Deviation between test devices displayed directly in dB with a single trace.

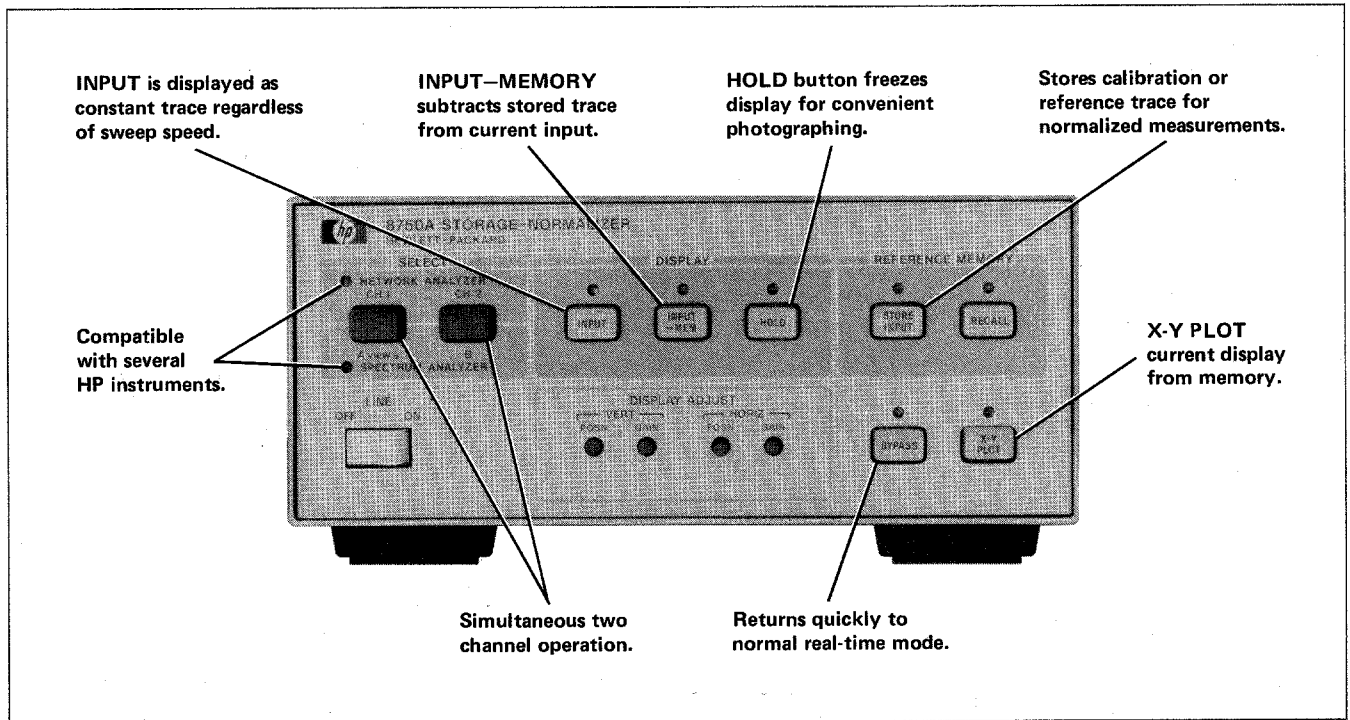


Figure 63. HP 8750A Storage-Normalizer. Digital storage and INPUT minus MEMORY provide flicker-free displays and trace normalization.

The Hewlett-Packard 8750A Storage-Normalizer and some of its main features are shown in Figure 63. CRT data are digitized and stored. The screen is then refreshed at a flicker-free rate while the memory is updated at the sweep speed. A separate memory is used to store a reference trace. The difference between input and memory is automatically displayed, resulting in a normalized display. The 8750's unique four memory system allows two channels of information to be stored, normalized, and viewed simultaneously.

The HP 8750A Storage-Normalizer is also used with several Hewlett-Packard Spectrum Analyzers and Network Analyzers. For compatibility and other information, refer to the data sheets for the 8750A or the HP 8755S Frequency Response Test Set.

**187-2 CONFIGURATION OF A 2-18 GHz SYNTHESIZED FREQUENCY SOURCE USING THE 8620C SWEEP OSCILLATOR**

Describes a configuration for a calculator controlled 2-18 GHz synthesized frequency source using the 8620C sweeper, UHF Synthesizer, and Hewlett-Packard Interface Bus.

**187-3 THREE HP-IB CONFIGURATIONS FOR MAKING MICROWAVE SCALAR MEASUREMENTS**

This application note describes three HP-IB configured systems for measuring the scalar transmission and impedance characteristics of microwave components. One employs the HP 436A Digital Power Meter, another the HP 8755 Frequency Response Test Set, and the third the HP 8410B Network Analyzer. The specific hardware requirements are discussed and the relative merits of each approach compared.

**187-4 CONFIGURATION OF A TWO-TONE SWEEPING GENERATOR**

Describes a configuration for a source which will allow sweep testing of mixers, receiver front ends, etc. The source outputs a local oscillator signal and a receiver signal whose offset from each other (the IF) is phase-locked. IF stability of  $<1$  Hz is realizable even while sweeping the RF from 2 to 18 GHz.

**187-5 CALCULATOR CONTROL OF THE 8620C SWEEP OSCILLATOR USING THE HP-IB**

Describes programmable capabilities of the 8620C and the procedures required to control it with the HP 9820A, 9821A, and 9830A/B Desktop Computers via the HP-IB. It also contains sample programs which can effectively improve the CW accuracy of the sweeper to approximately  $\pm 0.005\%$  of the bandwidth of the plug-in by using a counter feedback scheme.

**155-1 ACTIVE DEVICE MEASUREMENTS WITH THE HP 8755 FREQUENCY RESPONSE TEST SET**

Describes amplifier characterization using the 8755. Four configurations are presented for measurements of: Swept-frequency gain and power output, CW frequency gain compression, swept frequency gain compression, and swept frequency harmonic content.

**155-2 100 dB DYNAMIC RANGE MEASUREMENTS USING THE HP 8755 FREQUENCY RESPONSE TEST SET**

Describes measurement configurations for making 100 dB dynamic range swept transmission measurements. The note includes the theory of operation, equipment limitations and accuracy considerations.

**221 SEMI-AUTOMATIC MEASUREMENTS USING THE 8410B MICROWAVE NETWORK ANALYZER AND THE 9825A DESKTOP COMPUTER**

Describes the configuration of a semi-automatic network analyzer using the Hewlett-Packard Interface Bus (HP-IB). Topics treated include: block diagram of suggested equipment; methods of digitizing magnitude and phase readings; sources of error in microwave measurements; fundamentals of one-port vector error correction; a sample program for the 9825A Desktop Computer; and typical results and operating procedures.



5952-9200

PRINTED IN U.S.A.