

# APPLICATION NOTE 144

## Understanding Microwave Frequency Measurements

HEWLETT  PACKARD

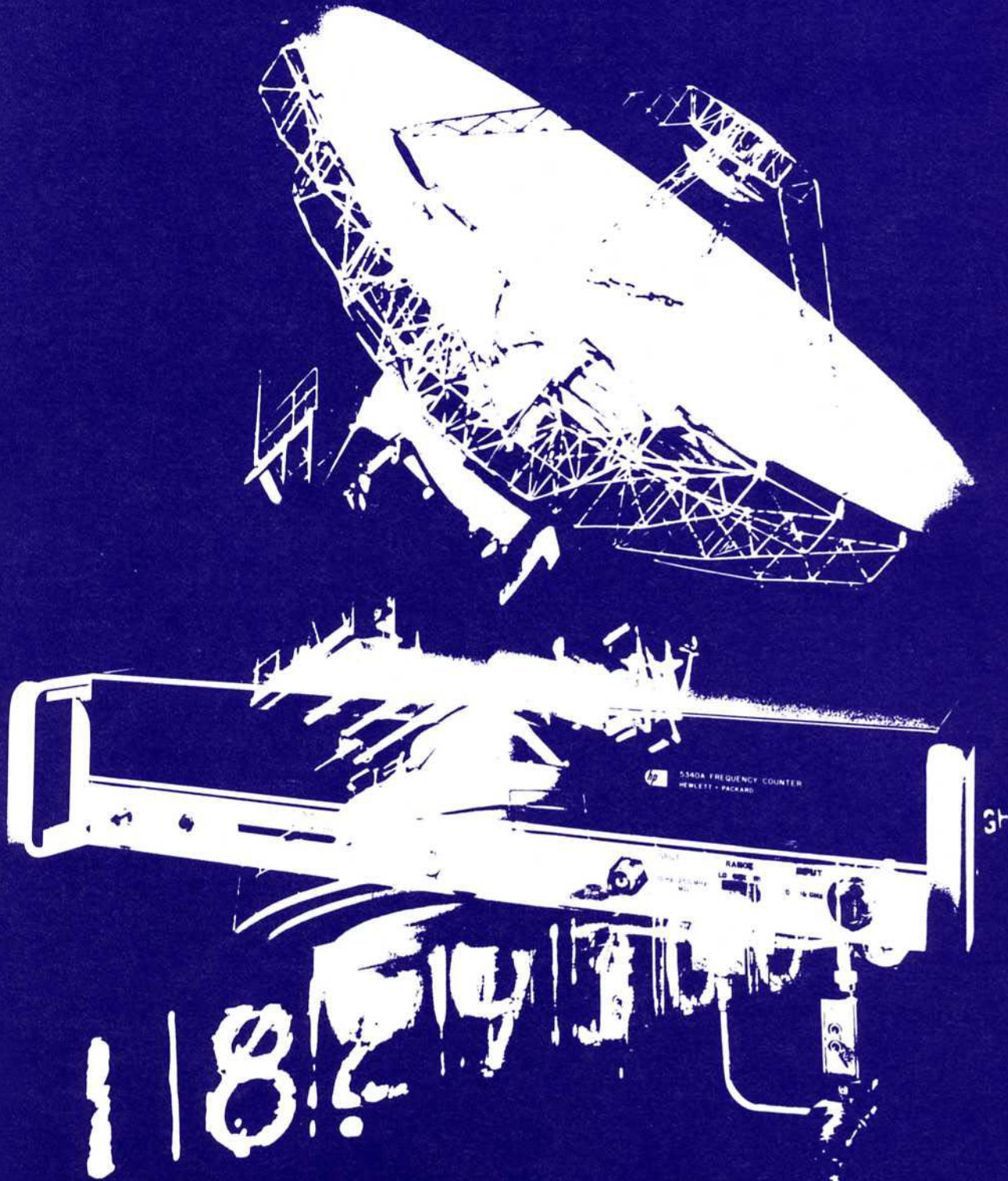

# I

## EXTENDING THE RANGE OF FREQUENCY COUNTERS INTO THE MICROWAVE SPECTRUM

A simple frequency counter today, designed with state-of-the-art digital components, can measure frequencies as high as 500 MHz by direct counting. The upper limit on frequency range is determined by the speed with which digital circuitry can toggle between the 1 and 0 states. Until higher speed digital circuitry is available, the designer of frequency counters must look to some form of down-conversion technique in order to extend the range of his counter beyond 500 MHz.

Frequency counters today with range greater than 500 MHz employ one of three frequency extension techniques:

1. Prescaling — Allowing measurements as high as 1.3 GHz;
2. Heterodyne Down-Conversion — Allowing measurements as high as 20 GHz;
3. Transfer Oscillator Down-Conversion — For measurements to 40 GHz and beyond.

### PRESCALING

Prescaling involves simple division of the input frequency resulting in a lower frequency signal which can be counted in digital circuitry. The frequency measured by the counter section is related to the input simply by the integer  $N$ . A display of the correct frequency is accomplished either by multiplying the counter's contents by  $N$  or by increasing the counter's gate time by a factor of  $N$ . Typically,  $N$  ranges from 2 to 16.

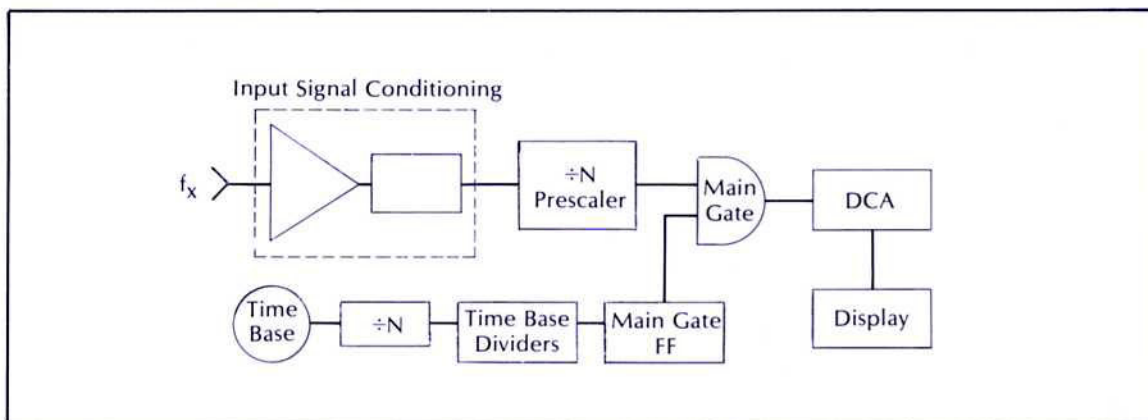

Figure 1. Block diagram of a high-frequency counter using the prescale down-conversion technique.

Figure 1 shows the block diagram of a high frequency counter using prescaling as its down-conversion technique. The input signal is conditioned to interact correctly with the prescaling circuit, and then it is divided by  $N$  before entering the main gate. Beyond this point the block diagram looks like a conventional counter, with the main gate being opened and closed (by the main gate flip-flop) in timing precisely determined by the crystal time base of the instrument. The decade counting assembly (DCA) now accumulates the under-500 MHz frequency measurement, which is multiplied by  $N$  and transmitted to the display.

Modern frequency counters using this technique are capable of measuring above 1.0 GHz. In the next five years this technique can be expected to produce counters measuring 1.5 to 2.0 GHz.

## HETERODYNE CONVERTER

Heterodyne down-conversion is a considerably more involved technique which allows frequency measurements to about 18 GHz. The key to this technique is a mixer which beats the incoming microwave frequency against a high-stability local oscillator signal, resulting in a difference frequency which is within the conventional counter's 500 MHz bandwidth.

Figure 2 is the block diagram of an automatic microwave counter using the heterodyne down-conversion technique. The down-converter section is enclosed by the dotted line. Outside the dotted line is the block diagram of a conventional counter, with the addition of a new block called the processor. The decision-making capability of a processor is necessary here in order to lead the counter through its measurement algorithm. The high stability local oscillator of Figure 2 is generated by first digitally multiplying the frequency of the instrument's time base to a convenient fundamental frequency (designated  $f_{in}$ ), typically 100 to 500 MHz. This  $f_{in}$  is directed to a harmonic generator which produces a "comb line" of frequencies spaced at  $f_{in}$  extending to the full frequency range of the counter. One line of this comb is then selected by the microwave filter and directed to the mixer. Since this frequency line is an integral multiple of  $f_{in}$ , it is designated  $Kf_{in}$ . The down-conversion process now occurs as follows: emerging from the mixer is a video frequency equal to  $f_x - Kf_{in}$ . This video frequency is amplified and sent to the counter. The display contains the sum of the video frequency and  $Kf_{in}$ , which is provided by the processor. (The processor stores the value of  $K$ , since it is in control of the microwave filter.)

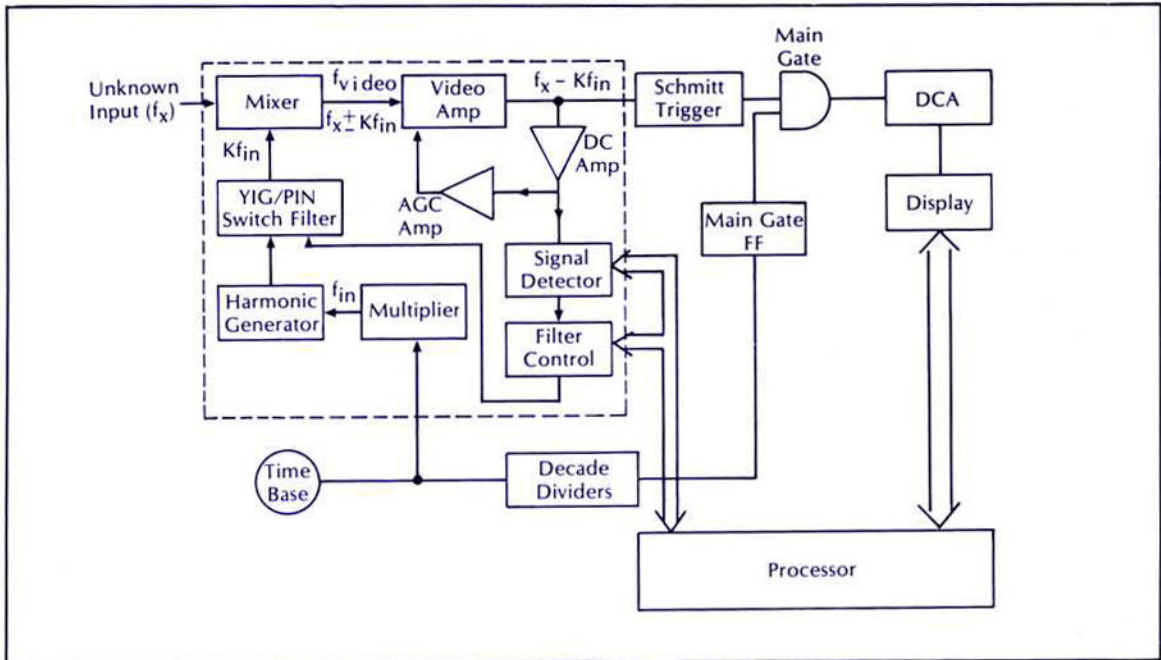

Figure 2. Block diagram of the heterodyne down-conversion technique.

The signal detector block in Figure 2 is necessary for determining the correct  $K$  value. In practice, the processor will begin with  $K = 1$  and will "walk" the value of  $K$  through the comb line until the signal detector determines that a video frequency is present. At this point the acquisition routine is terminated and measurement can begin.

The remaining block in Figure 2 which has not been discussed is the automatic gain control (AGC) circuit. This circuit provides a degree of noise immunity by desensitizing the video amplifier such that only the strongest frequency components of the video signal will enter the Schmitt trigger and be counted.

A key ingredient in automating the heterodyne down-conversion process is the microwave filter. Years ago this filter consisted of a resonant cavity which was tuned by the operator's turning a crank. Until quite recently this manual technique had a cost advantage over automated counters. Today, the process is automated through use of either a YIG filter or an array of thin film filters which are selected by PIN diode switches.

## TRANSFER OSCILLATOR

The transfer oscillator uses the technique of phase locking a low frequency oscillator to the microwave input signal. The low frequency oscillator can then be measured in a conventional counter, and all that remains to be accomplished is to determine the harmonic relationship between that frequency and the input.

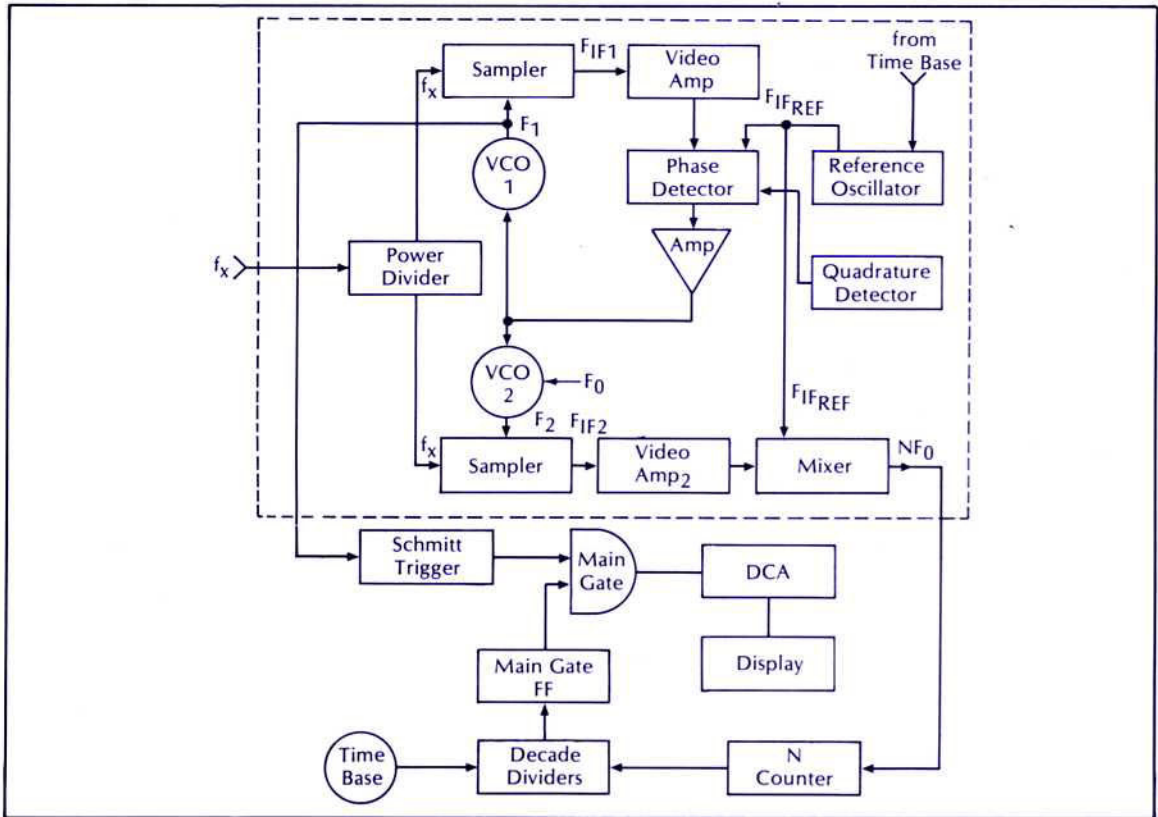

Figure 3. Block diagram of the transfer oscillator down-conversion technique.

Figure 3 is the block diagram of a microwave counter using the transfer oscillator technique. Once again, the down-conversion circuitry is contained within the dotted line. A processor is not necessarily included in the block diagram, although some decision-making ability is necessary in the acquisition process, just as with the heterodyne converter above.

In Figure 3 the input signal is shown being phase locked to a voltage controlled oscillator (VCO #1) in the upper portion of the converter section. Once phase lock is achieved, the relationship between the input and the VCO frequency is  $f_x = Nf_1$ , where  $N$  is an integer. The remainder of the down-converter circuitry is devoted to the task of determining  $N$ . The counter can now measure  $f_1$ , (typically 100-200 MHz) and multiply by  $N$  for a display of the microwave frequency. As in the case of prescaling above, this multiplication is usually accomplished by extending the gate time of the counter by a factor of  $N$  (which takes values from 1 to 200).

The quadrature detector in the phase lock loop of the automatic transfer oscillator insures that the output of VCO #1 bears the correct phase relationship with respect to the input signal.

As with the heterodyne converter, the transfer oscillator technique has been available in manually tuned form for many years. In the manual technique, phase lock is accomplished via the operator's manually tuning voltage controlled oscillator #1 and looking for a zero frequency difference in the video section via some type of display. The display can be either a simple cathode-ray tube or a dial. This technique requires the operator to find two adjacent VCO frequencies which are harmonically related to  $f_x$ . He then performs some arithmetic to calculate  $N$ . By manipulating thumb switches on the front panel he can cause the counter's gate time to be extended by  $N$ .



## II

# COMPARING THE PRINCIPAL MICROWAVE DOWN-CONVERSION TECHNIQUES

### MEASUREMENT SPEED

The time required for a microwave counter to perform a measurement may be divided into two parts:

1. Acquisition — The time necessary for the counter to detect a microwave signal and prepare to make a measurement; and
2. Gate Time — The duration of the counter's gate required to measure to a given resolution.

Each of the three down-conversion techniques we have discussed offers trade-offs in the area of measurement speed.

A prescaler will have fast acquisition time, typically equal to  $N$  cycles of the microwave input. The gate time for a prescaling counter will be equal to  $N/R$ , where  $R$  is the desired resolution in Hz and  $N$  is the prescale factor. As mentioned above, this extended gate time is required in order to effectively multiply the counter's contents by  $N$ .

The question of measurement speed is essentially the only difference between a prescaling counter and a conventional counter. Also, prescaling is limited to frequencies of 1.3 GHz or below. Since this note is principally concerned with microwave frequency measurements, we will therefore deal only with the two higher frequency down-conversion techniques.

The heterodyne converter, using the YIG filter, has an acquisition time ranging from 40 milliseconds to over 200 milliseconds. A design using thin film filters has an impressively short acquisition time of less than 1 millisecond. The gate time for heterodyne converter counters is  $1/R$ , unless the conventional portion of the counter uses prescaling (which is sometimes done to reduce cost).

A microwave counter using the transfer oscillator technique will typically have an acquisition time of about 150 milliseconds, which is comparable to the heterodyne converter. Gate times for the transfer oscillator are longer since, as with the prescaler, they must be set to  $N/R$ . This factor of  $N$  can cause the transfer oscillator counter to measure much more slowly than the heterodyne converter for high resolution (100 Hz or less) measurements of microwave frequencies. For typical measurements with resolution 1 kHz or greater, the difference in measurement speed between the two techniques will not be noticed by the operator.

### ACCURACY

The accuracy of microwave counter measurements is limited by two factors:

1. The plus/minus one-count quantization error; and
2. Time base errors.

Time base errors may further be looked at in two different ways: short-term stability, which generally limits the repeatability from one measurement to the next; and long-term stability, which limits the absolute accuracy of a measurement.

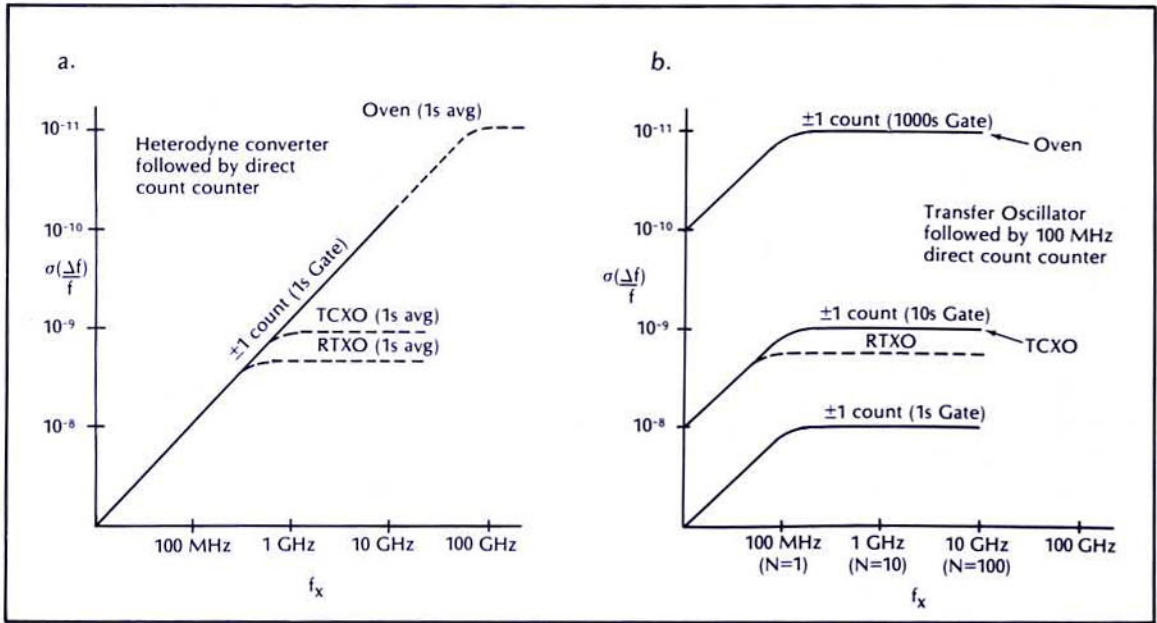

Figure 4. Resolution limitations of (a) the heterodyne converter, and (b) the transfer oscillator.

Figure 4 graphs the short-term stability (repeatability) of microwave measurements for each of the two down-conversion techniques. If gate time is limited to one second, it is clear that the transfer oscillator is limited to about  $1 \times 10^{-8}$  resolution. The heterodyne converter is limited to about  $1 \times 10^{-9}$ , where short-term instabilities of the crystal oscillator become the limiting factor. With the high stability of an oven oscillator, the heterodyne converter is capable of resolving one part in  $10^{10}$  at microwave frequencies.

Of considerably more importance to the user, however, are the long-term effects which limit the accuracy of microwave counter measurements. Figure 5 graphs the combined effects of inaccuracies due to time base aging and to the resolution of the counting technique. In this figure it is assumed that the time base was calibrated to a high degree of accuracy one month ago. Clearly, even with the best time bases available, the long-term instability of the time base becomes the accuracy limitation, no matter which down-conversion technique is used. It may therefore be concluded that accuracy is not a consideration in choosing between microwave down-conversion techniques for a particular application.

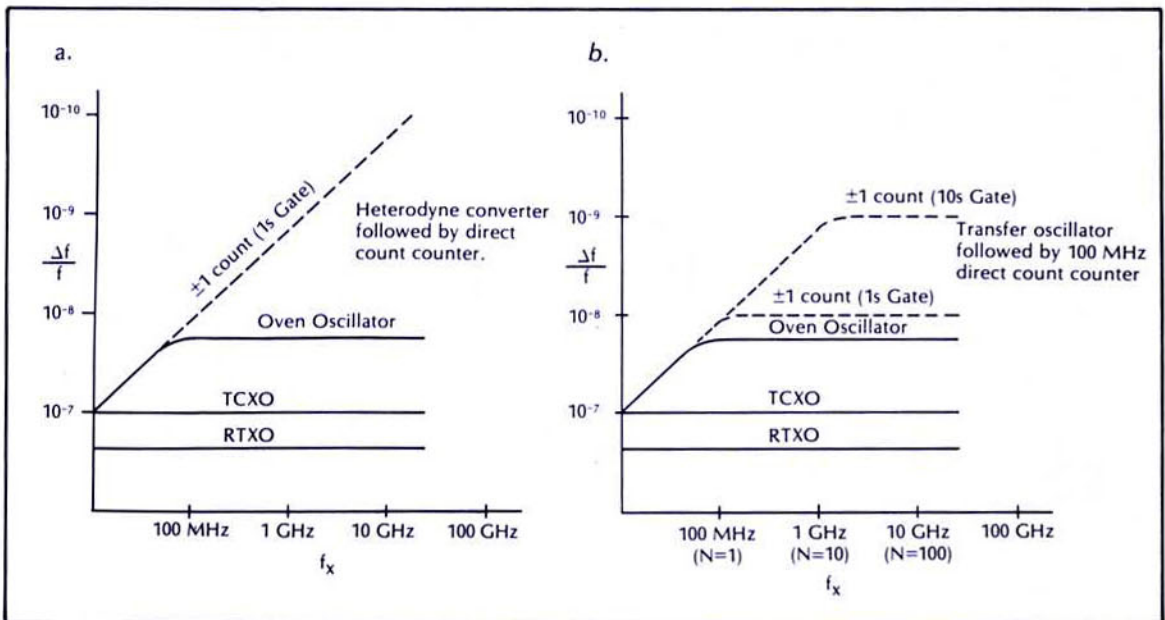

Figure 5. Accuracy limitations of (a) the heterodyne converter, and (b) the transfer oscillator.

## SENSITIVITY AND DYNAMIC RANGE

The sensitivity of a heterodyne converter must be chosen with great care. On the one hand, measurement of low level signals is essential in many microwave applications. On the other hand, since the effective input bandwidth of the heterodyne converter is so wide, a counter which is designed to be too sensitive might register false readings due to broadband low level noise. Figure 6 illustrates typical sensitivity specifications for heterodyne down-converter microwave counters, typically ranging from  $-20$  dBm to  $-25$  dBm.

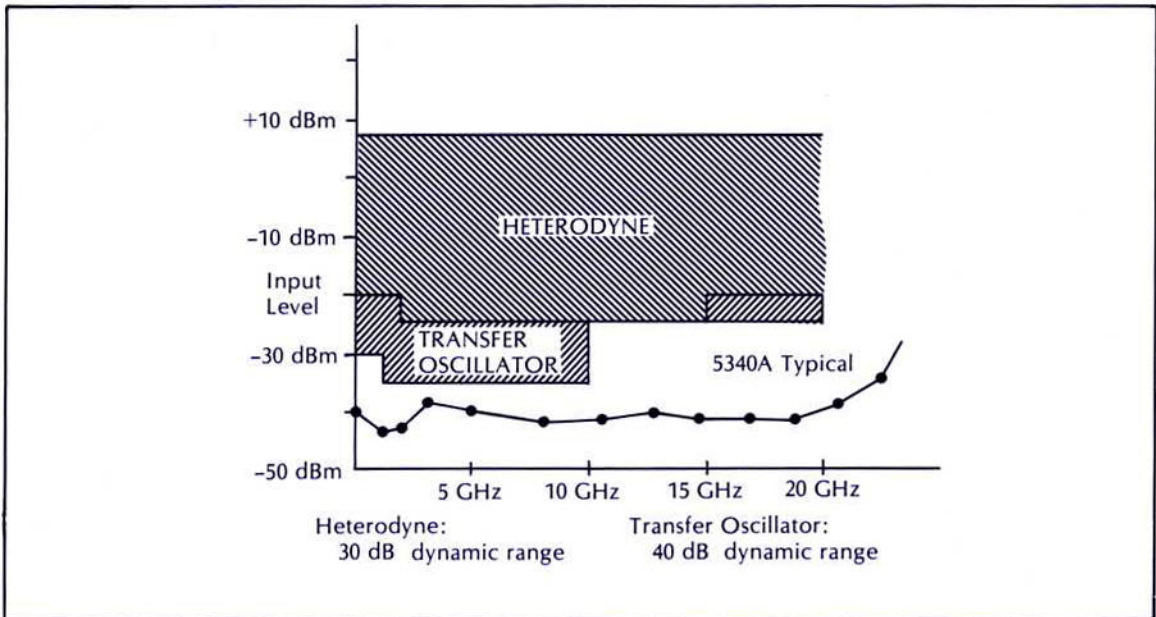

Figure 6. Plot of available sensitivity specifications of the transfer oscillator and heterodyne converter. Maximum measured input for both techniques is typically  $+7$  dBm.

The transfer oscillator offers an advantage in the area of sensitivity. Since the input signal into this down-converter enters a narrow band (about 200 kHz) phase lock loop, the problem of noise triggering is greatly diminished. Consequently, these counters can be constructed with exceptional sensitivity specifications. The lower solid line of Figure 6 indicates the sensitivity specification of the HP 5340A Frequency Counter, which ranges from  $-25$  dBm to  $-35$  dBm. The true sensitivity of a typical 5340A, ranging beyond  $-40$  dBm, also appears in Figure 6.

The dynamic range of a microwave counter is a measure of the separation of the sensitivity specification and the highest level input signal which can be counted reliably. A typical value for this upper level is  $+7$  dBm, which is also graphed in Figure 6. From this illustration it is clear that the technique with the greater sensitivity, that is, the transfer oscillator, will also have the greater dynamic range specification.

It should be noted that some microwave counters allow measurements of inputs to  $+20$  dBm and beyond; this specification is generally accompanied by lesser sensitivity. For instance, the HP 5341A Frequency Counter (4.5 GHz range) specifies a sensitivity of  $-15$  dBm and maximum measured input of  $+20$  dBm, for a dynamic range of 35 dB.

## SIGNAL-TO-NOISE RATIO

An important consideration in choosing a microwave counter is the signal-to-noise environment of the measurement. As mentioned in the above paragraph, the apparent amplifier bandwidth at the counter's input limits the amount of noise which the counter can tolerate on the measured signal.

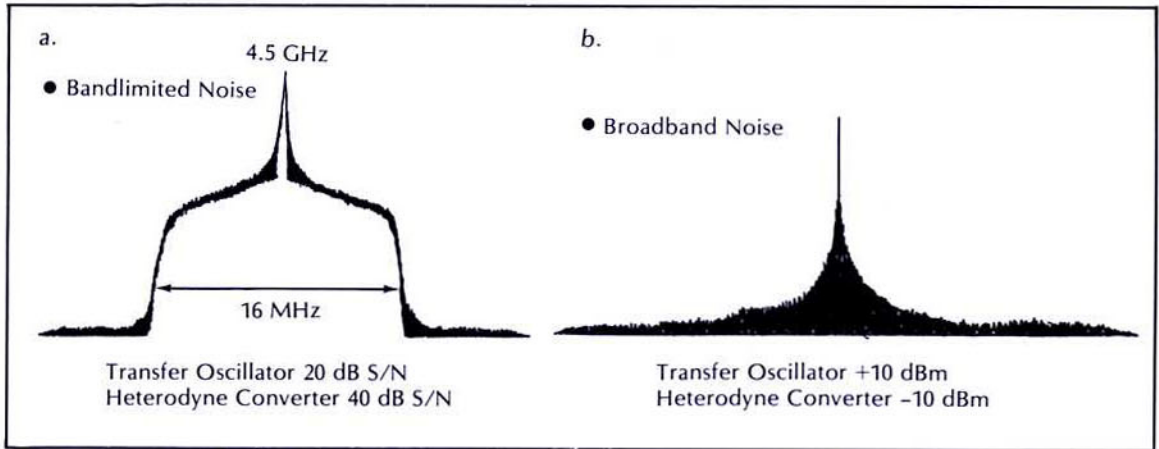

Figure 7. Spectral display of tests performed on microwave counters to determine signal-to-noise requirements. Tests included (a) bandlimited AM noise, and (b) broadband noise generated at the output of a solid-state microwave sweeper.

Consider a microwave frequency to be measured which has a good deal of noise surrounding the carrier. Such a situation is illustrated in Figure 7a. A transfer oscillator counter will be capable of measuring the signal if the peak carrier exceeds the noise floor by 20 dB. A typical heterodyne converter counter, however, will require 40 dB or greater separation to allow accurate measurement.

A common situation wherein broadband noise surrounds a signal to be measured is in the monitoring of solid state microwave sources. Figure 7b shows the typical output of a solid state sweeper. With this type of spectrum to be measured, a transfer oscillator will provide reliable readings up to the maximum sweeper output power (about +10 dBm). The typical heterodyne converter counter will encounter noise interference at sweeper output levels near -10 dBm.

### FM TOLERANCE

All modern microwave counters are capable of measuring today's microwave sources with their inherent incidental frequency modulation. There are applications, however, in which it is desired to measure a microwave communications carrier with frequency modulation present. In these cases the FM tolerance of microwave counters becomes a consideration for choosing the appropriate instrument.

A heterodyne converter may be thought of as dividing microwave frequency space into distinct bands, of a width equal to the comb line spacing. The design of these instruments is such that the video counting capability of the conventional counter is somewhat greater than the comb line spacing. It is this resulting overlap between adjacent bands that is the measure of the FM tolerance of the counter. Figure 8 illustrates the FM tolerance of the HP 5341A Frequency

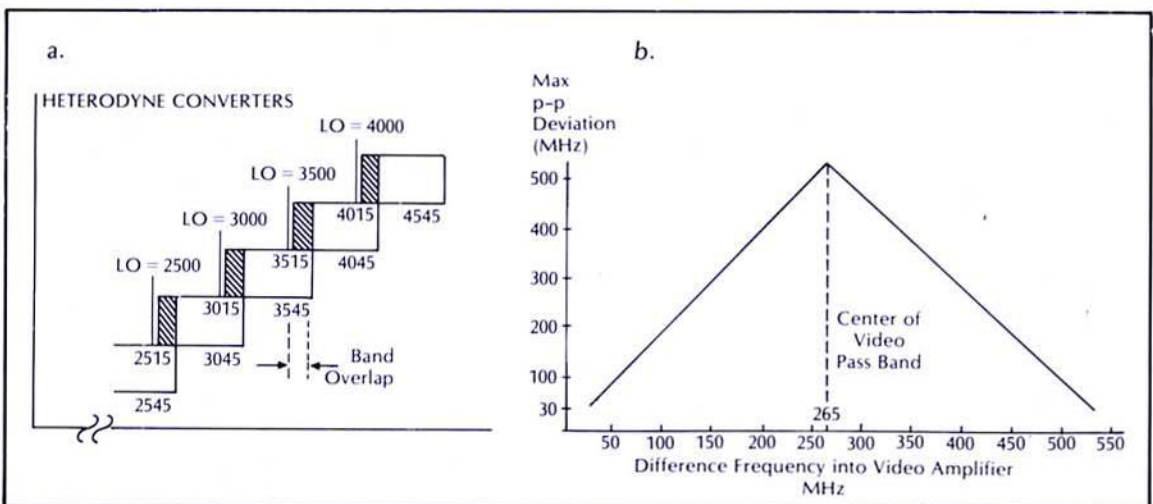

Figure 8. Analysis of the FM tolerance of the heterodyne down-conversion technique. The HP 5341A Frequency Counter is used as an example.

Counter. In this counter the comb line spacing is 500 MHz, but the video bandwidth of the counter is 530 MHz. (As seen in Figure 8a, a frequency measurement band begins 15 MHz above the comb line and ends 45 MHz above the next comb line.) As Figure 8b indicates, the FM tolerance of this particular design is over 500 MHz with the carrier located mid-band, and diminishes to 30 MHz at band edges. These are typical values for the heterodyne converter technique.

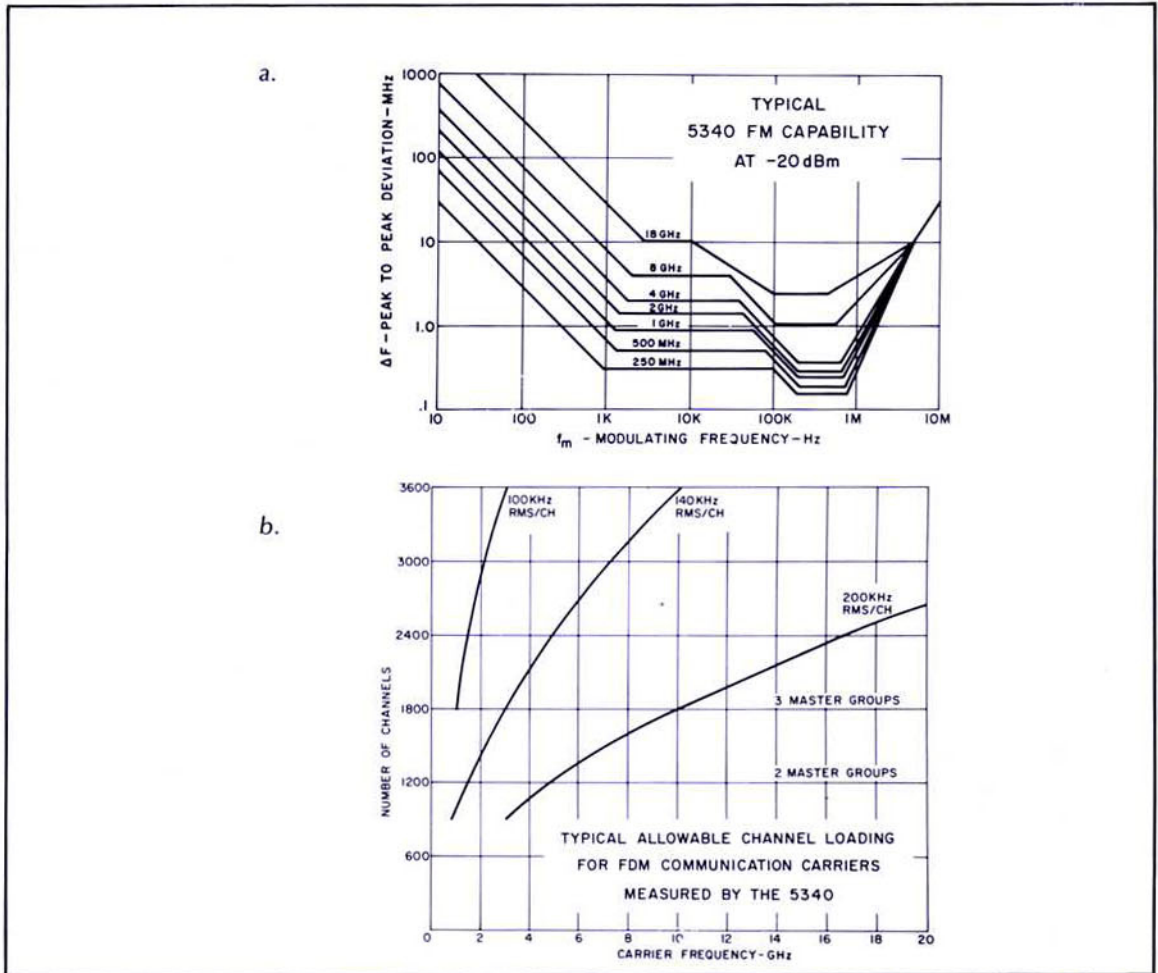

Figure 9. Graphical representation of the FM tolerance of a transfer oscillator counter — the HP 5340A Frequency Counter.

The transfer oscillator's tolerance of frequency modulation is more complex. As seen in Figure 9a, the maximum allowable peak-to-peak deviation is a function of modulating frequency and carrier frequency. In general, this tolerance is at a minimum at the point where modulating frequency is equal to the bandwidth of the input phase lock loop. If more than one tone modulates the carrier simultaneously (as in the case of the multi-channel communication modulation), the analysis of Figure 9a is no longer applicable. A typical response to multi-channel FM is shown in Figure 9b; this is a graph illustrating the capabilities of the HP 5340A Frequency Counter. On this chart tolerance to FM is indicated by the number of voice channels which are modulated onto the carrier. It can be seen that the FM tolerance of the transfer oscillator is in this case dependent upon carrier frequency and the per-channel loading of the radio. Since most microwave radios operate between 86 kHz RMS and 140 kHz RMS per-channel loading, it can be seen that a transfer oscillator like the HP 5340A is capable of measuring just about all fully loaded microwave communications carriers in use today.

In summary, although the transfer oscillator is capable of measuring microwave frequencies with all common forms of FM modulation, the heterodyne converter has a clear advantage in the area of FM tolerance.

## AM TOLERANCE

A second form of modulation frequently encountered in the microwave world is amplitude modulation. Few microwave radios use AM for communications transmissions, but nearly all microwave sources provide signals with incidental AM. Also, in many R & D and maintenance environments a time-varying attenuation of the signal is commonly encountered.

The heterodyne converter's tolerance to amplitude modulation is limited by its AGC circuitry when such a circuit is employed in the counter design. In Figure 2 we saw that the AGC circuit is used to provide a variable attenuation of the input according to the signal strength entering the counter. If the signal amplitude at the input varies due to AM, it is possible that the AGC circuitry will be unable to track the changing level and will prevent operation of the counter. A practical limitation of AM tolerance for the heterodyne converter is less than 50% AM.

The transfer oscillator suffers no such limitations with respect to AM. Essentially the only requirement of the transfer oscillator when measuring an amplitude modulated signal is that the lowest amplitude point of the waveform be strong enough that the counter can continue to measure. For example, the 5340A can easily measure a carrier at a level of  $-10$  dBm with 95% AM.

## AMPLITUDE DISCRIMINATION

Frequently a microwave counter will be called upon to measure a signal in the presence of other lower level signals. The ability to perform this measurement directly is referred to as amplitude discrimination.

The heterodyne converter will perform measurements in a multi-signal spectrum in very predictable fashion: It will acquire and measure the lowest frequency component of the spectrum which is above its sensitivity threshold. This situation is illustrated in Figure 10a. Of course, the lowest frequency component may not be the major signal in the spectrum; the solution to this situation is to provide the operator with the ability to manually select a higher band, thus providing the ability to measure more than one component of a complicated spectrum. We are still left with a problem, however: What happens when two significant frequency components are within the same band? The answer to this situation is that the AGC circuitry must be able to differentiate between the two signals. Typical AGC circuits found in heterodyne converters today provide discrimination between signals which lie from 4 dB to 30 dB apart, located in the same band.

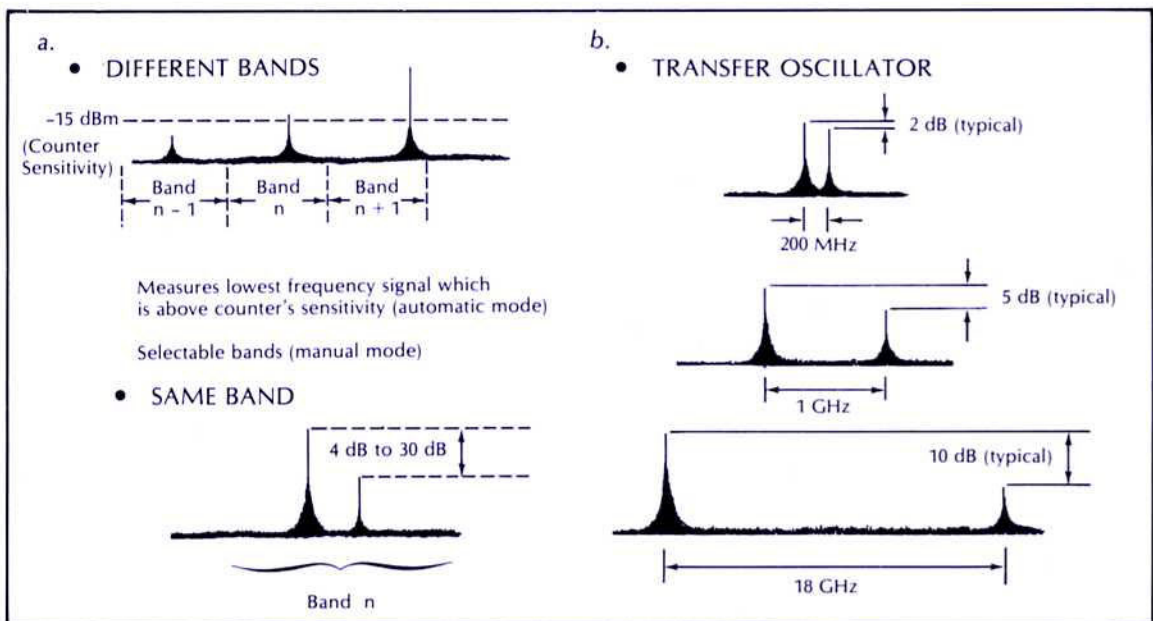

Figure 10. Typical amplitude discrimination capabilities of (a) the heterodyne converter, and (b) the transfer oscillator.

Automatic amplitude discrimination is one of the key features of the transfer oscillator design. These counters are typically capable of always finding the most prominent component of the spectrum, provided that it is at least 2 dB above nearby signals and at least 10 dB above signals at the far end of the counter's frequency range. Figure 10b is an illustration of these measurement capabilities.

## SUMMARY OF THE COMPARISON

Thus far in this note we have examined the performance trade-offs between the heterodyne converter and the transfer oscillator down-conversion techniques for microwave counters. The results of these trade-offs are tabulated in Figure 11. It should be noted that these comparisons are made on the basis of typical specifications; a comparison of individual instruments may result in different results in some categories.

Characteristic	Heterodyne	Transfer Oscillator
Frequency Range	20 GHz	40 GHz ✓
Measurement Speed	150 ms acquisition 1/R Gate ✓	150 ms acquisition N/R Gate
Accuracy	Time base limited	Time base limited
Sensitivity/Dynamic Range	-25 dBm / 30 dB	-35 dBm / 40 dB ✓
Signal-to-Noise Ratio	40 dB	20 dB ✓
FM Tolerance	30-40 MHz peak-peak ✓	1-10 MHz peak-peak
AM Tolerance	Less than 50%	Greater than 90 % ✓
Amplitude Discrimination	Displays lowest frequency	Displays strongest frequency ✓

Figure 11. Summary of the performance of the two principal microwave down-conversion techniques.

### III

## ADDITIONAL CONSIDERATIONS IN CHOOSING A MICROWAVE COUNTER

### SIGNAL INPUTS

The first check of the inputs to a microwave counter is to insure that the frequency ranges covered by the various input connectors satisfy the requirements of the application. At times, it can be burdensome to be continually changing the input connector from one spigot to another. Of course, the ideal situation in a systems application is for one connector to cover the full frequency range of the counter. Also, are the connector types appropriate for the frequency range involved? For example, a Precision Type N connector may begin to display high SWR with input very much over 18 GHz.

SWR, of course, is quite important in selecting test equipment; good SWR specifications should always be required of a microwave counter.

High impedance inputs are also necessary for some applications to avoid perturbing the circuit under test. A question to be asked here: Does the high impedance input of the microwave counter satisfactorily cover the full range of applications for high impedance probing? For instance, it is often necessary to use a high impedance input for measurements at the IF of microwave radios.

A consideration of great importance in microwave counters is that of damage level limitations on the input signal level. Well-designed microwave counters today can tolerate up to +30 dBm inputs without damage.

### SYSTEMS INTERFACE

A consideration of growing importance today in the test equipment world is that of systems compatibility of instruments. For years, specifying this type of compatibility has been impossible due to the lack of a recognized standard. Since the IEEE adopted standard #488 in 1975, however, an elegant solution to systems compatibility for all forms of test instruments has been a reality. The Hewlett-Packard Interface Bus, which is HP's implementation of IEEE-488, allows programming and data output of microwave counters using the ASCII code via an 8-bit bi-directional bus.

### IF OFFSETS

In some communications applications of microwave counters, it is convenient to have the counter's display offset by some constant. This is a feature which is available in most microwave counters today. An additional consideration here is that more than one IF offset may be required in the same application, so the selection of 0, 1, 2 or more offsets in the same counter may be a necessary feature.

## IV

# ADVANCED MICROWAVE FREQUENCY MEASUREMENTS

Microwave counters may be employed for measurements other than that of the average frequency of a CW signal. These additional measurements are detailed in other application notes, and they will merely be summarized here.

Amplitude modulation of microwave signals may be measured by displaying the down-converted IF from either a transfer oscillator or heterodyne converter on an oscilloscope. See HP Application Note 141, "AM, FM Measurements with the Transfer Oscillator", for descriptions of this measurement.

Frequency modulation may be measured using a manually-tuned transfer oscillator down-converter and oscilloscope. The same technique is also applicable to measurements of frequency profiles ("chirp") within microwave pulses. AN 141 also describes these measurements in detail.

A major microwave measurement need is that of the average frequency within pulse streams. HP Application Note 173, "Recent Advances in Pulsed RF and Microwave Frequency Measurements", describes this measurement using either heterodyne or transfer oscillator down-converters. An exciting new development described in AN 173 is that these measurements may now be accomplished **automatically** for the first time, using the HP 5345A Electronic Counter and 5354A 4 GHz Automatic Frequency Converter.

A microwave frequency measurement which is receiving increased attention is the frequency-vs-time profile of fast-tuning voltage controlled oscillators (VCO's). This measurement requires a sophisticated microwave counter which is capable of being gated by an externally applied signal. HP Application Note 173-1, "Dynamic Measurement of Microwave VCO's with the 5345A Electronic Counter", discusses these measurements in detail.



For more information, call your local HP Sales Office or East (301) 948-6370 • Midwest (312) 677-0400 • South (404) 434-4000 • West (213) 877-1282. Or, write: Hewlett-Packard, 1501 Page Mill Road, Palo Alto, California 94304. In Europe, Post Office Box 349, CH-1217 Meyrin 1, Geneva, Switzerland. In Japan, Yokogawa-Hewlett-Packard, 1-59-1, Yoyogi, Shibuya-Ku, Tokyo, 151.

02-5952-7426

Printed in USA