

Agilent Technologies Wireless Test Solutions

Application Note 1313

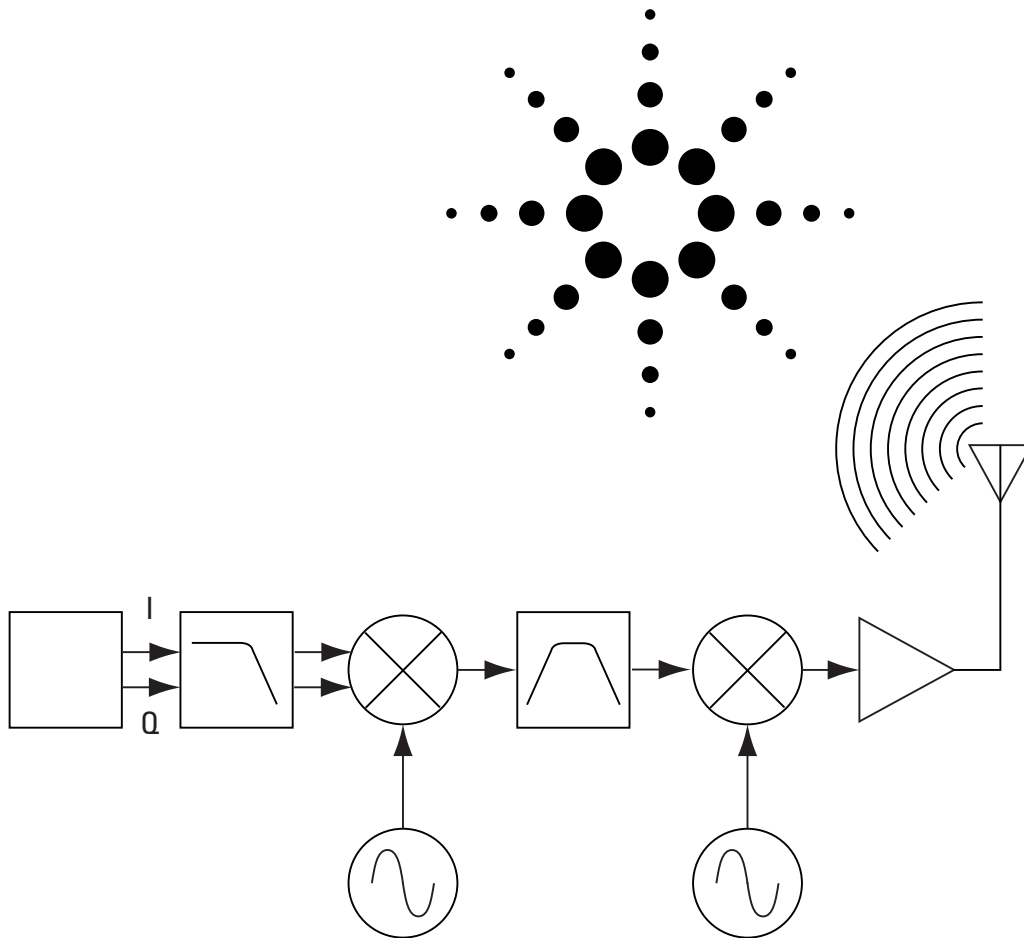

Testing and Troubleshooting Digital RF Communications Transmitter Designs



Introduction

The demand for ubiquitous wireless communications is challenging the physical constraints placed upon current wireless communications systems. In addition, wireless customers expect wireline quality from their service providers. Service providers have invested a lot in a very limited slice of the radio spectrum. Consequently, network equipment manufacturers must produce wireless systems that can be quickly deployed and provide bandwidth-efficient communications.

At early stages of equipment design, rigorous testing is performed to ensure system interoperability. The increasingly complex nature of digital modulation is placing additional pressure on design teams, already faced with tight project deadlines. Not only must the designer test to conformance; he must also quickly infer possible problem causes from measurement results.

The objective of this application note is to help you understand why the different transmitter tests are important and how they identify the most common impairments in transmitter designs.

The application note focuses on cellular communications transmitters, although some of the measurements and problems described may also apply to other digital communications systems.

This application note covers the following topics:

1. How digital communications transmitters work.
2. How to test transmitters and what test equipment characteristics are important.
3. The common impairments of a transmitter and how to troubleshoot them.

The following information is also included as reference material:

- A detailed troubleshooting procedure (Appendix A).
- A table of instrument capabilities (Appendix B).
- A glossary of terms.
- A list of reference literature.

The first two chapters in the application note, covering topics 1 and 2, are targeted at new R&D engineers who have a basic knowledge of digital communications systems. The third chapter is targeted at R&D engineers with some experience in testing digital communications transmitter designs. For basic information on digital modulation techniques—essential background for this application note—please refer to:

*Digital Modulation in Communications Systems—
An Introduction [1].*

The measurements and problems described apply to most wireless communications systems. Some measurements specific to common technologies or standards are also mentioned. For more detailed information on CDMA and GSM measurements, please refer to:

*Understanding CDMA Measurements for Base Stations
and Their Components [2]*

*Understanding GSM Transmitter Measurements for
Base Transceiver Stations and Mobile Stations [3].*

*Understanding PDC and NADC Transmitter Measurements
for Base Transceiver Stations and Mobile Stations [4].*

Although this application note includes some references to digital communications receivers, it does not cover measurements and possible impairments of receivers. For more information on digital communications receivers, please refer to:

*Testing and Troubleshooting Digital RF Communications
Receiver Designs [5].*

Note: The above application notes can be downloaded from the Web at the following URL and printed locally:

<http://www.agilent.com/find/wireless>

Table of Contents

1. Wireless Digital Communications Systems	6
1.1 Digital communications transmitter	6
1.1.1 Analog I/Q modulator versus digital IF	7
1.1.2 Other implementations	8
1.2 Digital communications receiver	8
2. Testing Transmitter Designs	9
2.1 Measurement model	9
2.2 Measurement domains	10
2.2.1 Time domain	10
2.2.2 Frequency domain	10
2.2.3 Modulation domain	11
2.3 In-band measurements	12
2.3.1 In-channel measurements	12
2.3.1.1 Channel bandwidth	12
2.3.1.2 Carrier frequency	12
2.3.1.3 Channel power	13
2.3.1.4 Occupied bandwidth	14
2.3.1.5 Peak-to-average power ratio and CCDF curves	14
2.3.1.6 Timing measurements	16
2.3.1.7 Modulation quality measurements	17
2.3.1.7.1 Error Vector Magnitude (EVM)	17
2.3.1.7.2 I/Q offset	20
2.3.1.7.3 Phase and frequency errors	20
2.3.1.7.4 Frequency response and group delay	21
2.3.1.7.5 Rho	22
2.3.1.7.6 Code-domain power	22
2.3.2 Out-of-channel measurements	23
2.3.2.1 Adjacent Channel Power Ratio (ACPR)	23
2.3.2.2 Spurious	25
2.4 Out of-band measurements	25
2.4.1 Spurious and harmonics	25
2.5 Best practices in conducting transmitter performance tests	26

- 3. Troubleshooting Transmitter Designs 27**
 - 3.1 Troubleshooting procedure 27
 - 3.2 Impairments 28
 - 3.2.1 Compression. 29
 - 3.2.2 I/Q impairments 32
 - 3.2.3 Incorrect symbol rate. 37
 - 3.2.4 Wrong filter coefficients and incorrect windowing. 39
 - 3.2.5 Incorrect interpolation. 42
 - 3.2.6 Filter tilt or ripple. 46
 - 3.2.7 LO instability 48
 - 3.2.8 Interfering tone. 51
 - 3.2.9 AM-PM conversion. 52
 - 3.2.10 DSP and DAC impairments 54
 - 3.2.11 Burst-shaping impairments 58
- 4. Summary 60**
- Appendix A: Detailed Troubleshooting Procedure 61**
- Appendix B: Instrument Capabilities 62**
- 5. Glossary 63**
- 6. References 64**
- 7. Related Literature 64**

1. Wireless Digital Communications Systems

The performance of a wireless communications system depends on the transmitter, the receiver and the air interface over which the communications take place. This chapter shows how a digital communications transmitter works and discusses the most common variations of transmitters. Finally, it briefly describes how the complementary digital communications receiver works.

1.1 Digital communications transmitter

Figure 1 shows a simplified block diagram of a digital communications transmitter that uses I/Q modulation. I/Q modulators are commonly used in high-performance transmitters.

This application note focuses on the highlighted section of Figure 1. Measurements and common impairments for this section of the transmitter will be described in the following chapters. Previous stages in the transmitter include speech coding (assuming voice transmission), channel coding, and interleaving. Speech coding quantizes the analog signal and converts it into digital data. It also applies compression to minimize the data rate and increase spectral efficiency. Channel coding and interleaving are common techniques that provide protection from errors. The data is also processed and organized into frames. The frame structure depends on the specific system or standard followed.

Figure 1.
Block diagram
of a digital
communications
transmitter

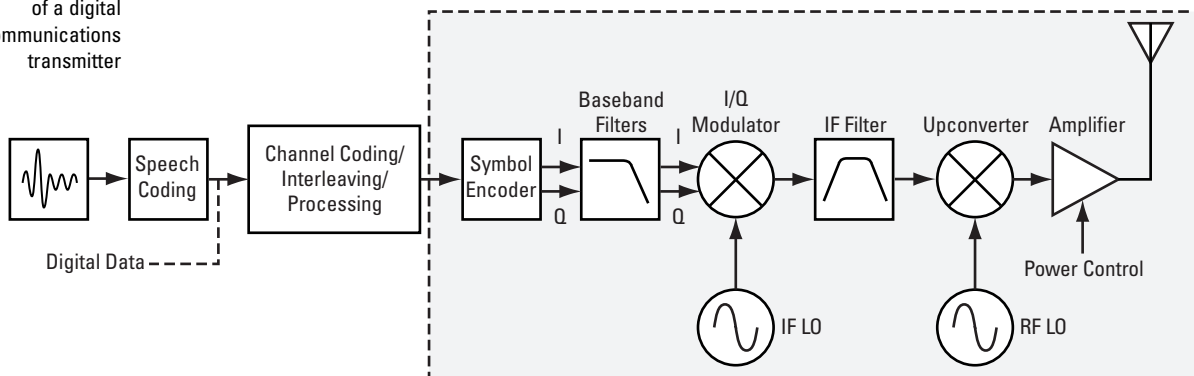

The symbol encoder translates the serial bit stream into the appropriate I and Q baseband signals, corresponding to the symbol mapping on the I/Q plane for the specific system. An important part of the encoder is the symbol clock, which defines the frequency and exact timing of the transmission of the individual symbols.

Once the I and Q baseband signals have been generated, they are filtered. Filtering slows the fast transitions between states, thereby limiting the frequency spectrum. The correct filter must be used to minimize intersymbol interference (ISI). Nyquist filters are a special class of filters that minimize ISI while limiting the spectrum. In order to improve the overall performance of the system, filtering is often shared between the transmitter and the receiver. In that case, the filters must be compatible and correctly implemented in each to minimize ISI.

The filtered I and Q baseband signals are fed into the I/Q modulator. The local oscillator (LO) in the modulator can operate at an intermediate frequency (IF) or directly at the final radio frequency (RF). The output of the modulator is the combination of the two orthogonal I and Q signals at IF (or RF). After modulation, the signal is upconverted to RF, if needed.

The RF signal is often combined with other signals (other channels) before being applied to the output amplifier. The amplifier must be appropriate for the signal type.

1.1.1 Analog I/Q modulator versus digital IF

Although digital communications transmitters can be designed using analog hardware, there is a clear trend toward implementing part of the system digitally. The section of the system designed digitally can vary from radio to radio. Therefore, the location of the Digital-to-Analog Converter (DAC) varies.

For instance, while baseband filters are usually implemented digitally as FIR (finite impulse response) filters, the I/Q modulator has traditionally been designed using analog hardware. In this case two DACs (one for each path) are applied prior to the I/Q modulator. However, there is an increasing tendency to implement the I/Q modulator digitally (digital IF), which leads to more stable results. In this case a DAC is located at the IF. In any case, the signal is analog at RF.

Figure 2. Usual implementations of a transmitter: (a) analog I/Q modulator (b) digital IF

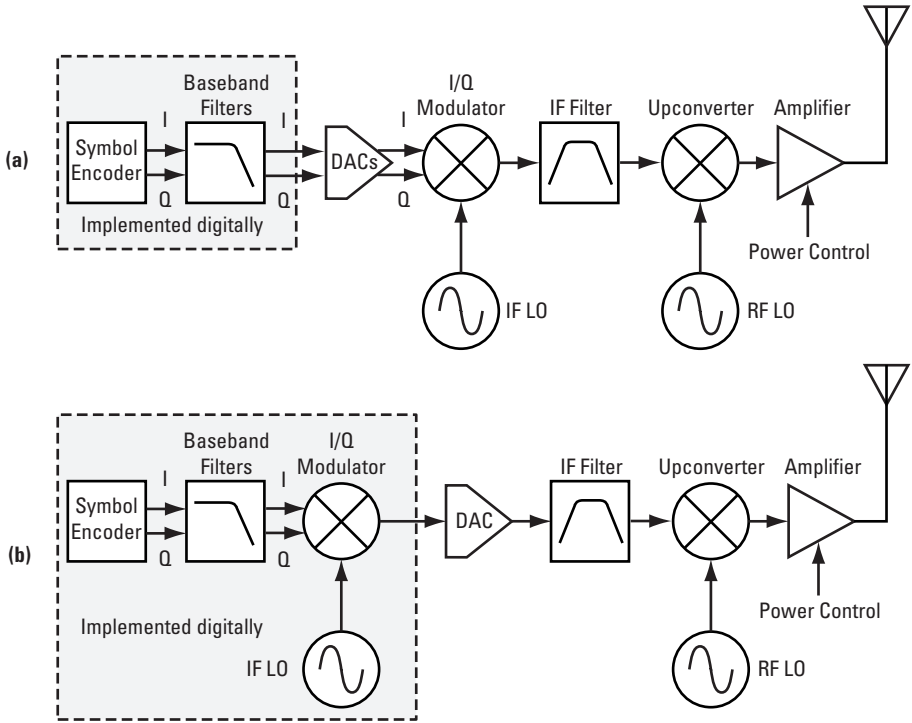

Digital implementations of the baseband and IF sections of the transmitter avoid some of the typical impairments caused by analog hardware. Drift errors due to component aging are also eliminated. However, digital hardware can also cause impairments, as we will see in the last chapter of this application note.

1.1.2 Other implementations

In practice, there are many variations of the general block diagrams discussed above. These variations depend mainly on the characteristics of the technology used; for example, the type of multiplexing (TDMA or CDMA) and the specific modulation scheme (such as OQPSK or GMSK).¹

For instance, GSM¹ transmitters can be easily implemented using analog frequency modulators (Figure 3). Since intersymbol interference is not as critical in GSM systems, Gaussian baseband filtering is used instead of Nyquist filters [1]. I/Q modulators are only used in high-performance GSM transmitters.

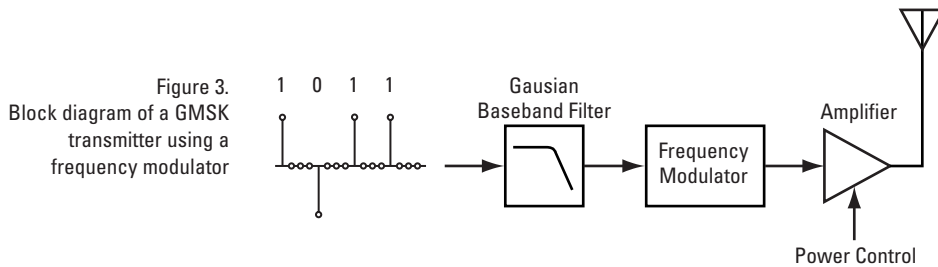

Figure 3. Block diagram of a GMSK transmitter using a frequency modulator

Different implementations and systems have different design problems and often require specific measurements. For instance, in TDMA technologies, burst parameters must be measured to ensure that interference with adjacent frequency channels and adjacent timeslots are within acceptable limits. The most common measurements and problems associated with particular technologies will be discussed in the following chapters.

1.2 Digital communications receiver

The typical receiver (Figure 4) is essentially an inverse implementation of the transmitter. Although an I/Q demodulator is often used, there are other digital communications receiver designs.

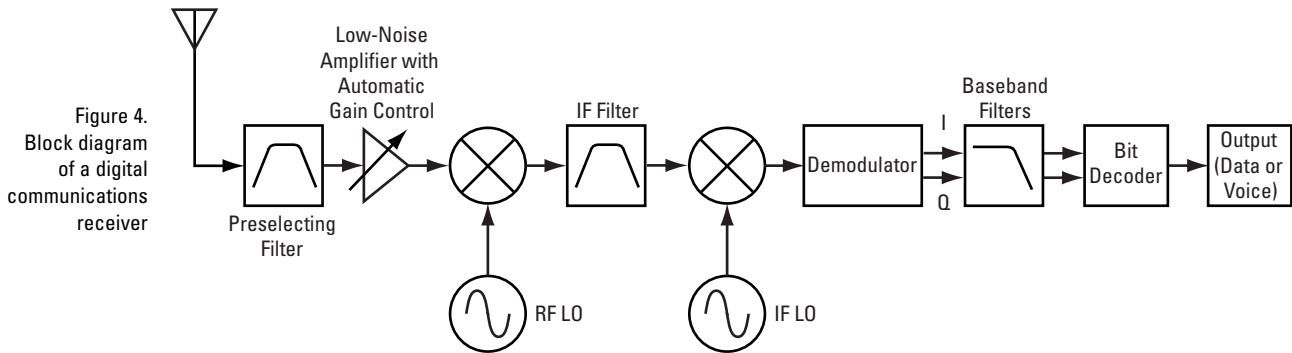

Figure 4. Block diagram of a digital communications receiver

The receiver configuration also depends on the specific system and performance required. For instance, in high-performance cellular receivers, equalization is commonly used to combat ISI caused by impairments in the transmitter, the air interface or the early stages of the receiver itself.

A more detailed description of digital receivers can be found in the companion application note, *Testing and Troubleshooting Digital RF Communications Receiver Designs* [5].

¹See Glossary for the meanings of these acronyms.

2. Testing Transmitter Designs

There are several testing stages during the design of a digital communications transmitter. The different components and subsections are initially tested individually. When appropriate, the transmitter is fully assembled, and system tests are performed. During the design stage of product development, verification tests are rigorous to make sure that the design is robust. These rigorous conformance tests verify that the design meets system requirements, thereby ensuring interoperability with equipment from different manufacturers.

This chapter covers testing of the highlighted part of the transmitter in Figure 1. It describes the conformance tests and other common measurements made at the antenna port. Most of the transmitter measurements are common to all digital communications technologies, although there are some variations in the way the measurements are performed. Particular technologies, such as CDMA or TDMA, require specific tests that are also described.

2.1 Measurement model

Transmitter measurements are typically made at the antenna port, where the final signal is emitted. In this case, the measurement equipment is used as an ideal receiver.

It may also be necessary to examine the transmitter at various test points as the different sections are designed (see Figure 5). In this case, a stimulus signal might be required to emulate those sections that are not yet available. The equipment for doing this acts as an ideal substitute for the missing circuit or sections. Unmodulated carrier signals have traditionally been used as the stimuli for some component and subsystem measurements, such as frequency response, group delay or distortion measurements. However, complex digitally-modulated stimulus signals are increasingly used, as they may provide more realistic measurement results.

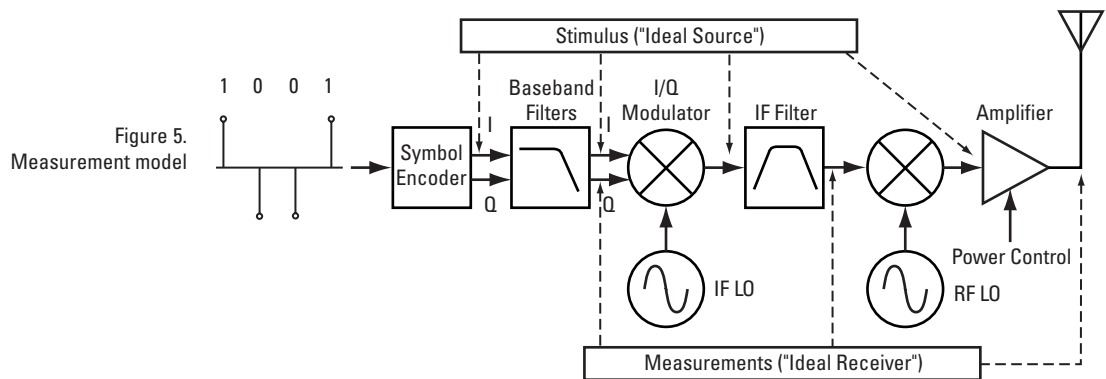

Figure 5. Measurement model

Sometimes individual blocks or components cannot be isolated and the measurement can only be made at the final stage of the transmitter. Therefore, you may be forced to infer the causes of problems from measurements at the antenna port. The ideal testing tool is not only able to perform the measurements but also has the flexibility to provide insight about system impairments by analysis of the transmitted signal. This application note focuses on transmitter measurements and troubleshooting techniques performed at the antenna port, although in practice some of these measurements can also be made at other locations in the transmitter. For instance, signal quality measurements can be performed on the RF, IF or baseband sections of the transmitter.

2.2 Measurement Domains

The transmitted signal can be viewed in different domains. The time, frequency and modulation domains provide information on different parameters of a signal. The ideal test instrument can make measurements in all three domains.

Two types of transmitter test instruments are discussed: the spectrum analyzer (SA) and the vector signal analyzer (VSA). Their measurement capabilities in each domain are described in the following sections of this chapter. Refer to Appendix B for a list of spectrum analyzers and vector signal analyzers from Agilent Technologies and their capabilities for measuring and troubleshooting digital communications transmitters.

2.2.1 Time domain

Traditionally, looking at an electrical signal meant using an oscilloscope to view the signal in the time domain. However, oscilloscopes do not band limit the input signal and have limited dynamic range. Vector signal analyzers downconvert the signal to baseband and sample the I and Q components of the signal. They can display the signal in various coordinate systems, such as amplitude versus time, phase versus time, I or Q versus time, and I/Q polar. Swept-tuned spectrum analyzers can display the signal in the time domain as amplitude (envelope of the RF signal) versus time. Their capability can sometimes be extended to measure I and Q.

Time-domain analysis is especially important in TDMA technologies, where the shape and timing of the burst must be measured.

2.2.2 Frequency domain

Although the time domain provides some information on the RF signal, it does not give us the full picture. The signal can be further analyzed by looking at its frequency components (Figure 6). Both spectrum analyzers and vector signal analyzers can perform frequency-domain measurements. The main difference between them is that traditional spectrum analyzers are swept-tuned receivers, while vector signal analyzers capture time data and perform Fast Fourier Transforms (FFTs) to obtain the frequency spectrum. In addition, the VSAs measure both the magnitude and phase of a signal.

Figure 6.
Time and frequency domains

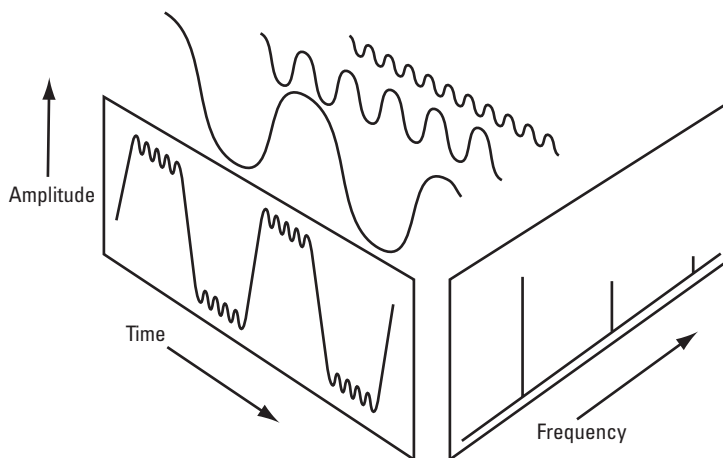

Measurements in the frequency domain are especially important to ensure that the signal meets the spectral occupancy, adjacent channel, and spurious interference requirements of the system.

2.2.3 Modulation domain

If the RF signal is demodulated, the quality of the baseband signal can be analyzed by comparing it to an ideal reference. This reference is usually mathematically derived by the instrument, provided that the original data sequence can be recovered. Demodulation involves applying the appropriate filtering before recovering the baseband I and Q signals and sampling these signals at the symbol rate to recover the actual symbols (Figure 7).

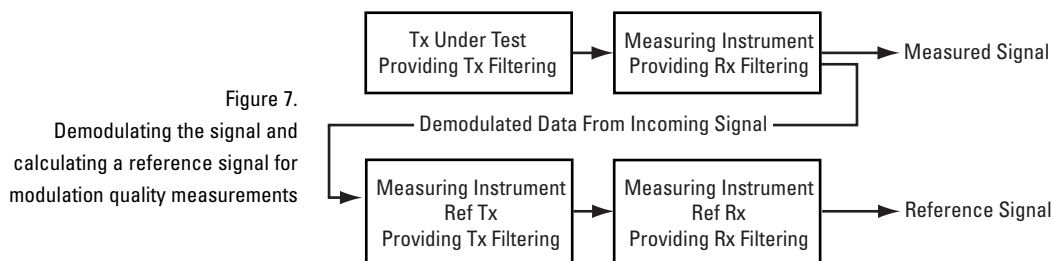

Vector signal analyzers can demodulate the signal and make modulation quality measurements. A swept-tuned spectrum analyzer with additional hardware and software can also demodulate and analyze modulation quality.

Various display formats and capabilities can be used to view the baseband signal characteristics and analyze modulation quality:

- I/Q polar (vector) and constellation diagrams.
- Summary table with I/Q quality metrics, such as Error Vector Magnitude (EVM), magnitude error, phase error, frequency error, rho and I/Q offset.
- Magnitude of the error vector versus time and error vector versus frequency (error vector spectrum).
- Magnitude error and phase error versus time or frequency.
- Eye and Trellis diagrams.
- Symbol table.
- Equalization, which allows frequency response and group delay measurements.
- Code-domain analysis.

Some of these display formats and capabilities are briefly described in the modulation quality measurement sections in this chapter. For more detailed descriptions of the common modulation-quality displays, please see [1].

Combinations of the display formats and capabilities above can be used to troubleshoot potential problems in the design, as we will see in the next chapter. Additionally, analog demodulation tools, such as phase demodulation or frequency demodulation, can be used to troubleshoot particular problems in a digital communications transmitter. For example, phase demodulation is often used to troubleshoot instability at a particular LO, as described in the next chapter.

2.3 In-band measurements

The measurements required to test digital communications transmitters can be classified as in-band and out-of-band measurements regardless of the technology used and the standard followed.

In-band measurements are measurements performed within the frequency band allocated for the system; for example, 890 MHz to 960 MHz for GSM. In-band measurements can be further divided into in-channel and out-of-channel measurements.

2.3.1 In-channel measurements

The definition of channel in digital communications systems depends on the specific technology used. Apart from multiplexing in frequency and space (geography), the common cellular digital communications technologies use either time or code multiplexing. In TDMA technologies, a channel is defined by a specific frequency and timeslot¹ number in a repeating frame¹, while in CDMA technologies a channel is defined by a specific frequency and code. The terms in-channel and out-of channel refer only to the specific frequency band of interest (frequency channel), and not to the specific timeslot or code channel within that frequency band.

2.3.1.1 Channel bandwidth

When testing a transmitter, it is usually a good idea to first look at the spectrum of the transmitted signal. The spectrum shape can reveal major errors in the design. For a transmitter with a root-raised cosine filter, the 3dB bandwidth of the modulated frequency channel should approximate the symbol rate. For instance, in Figure 8, for a symbol rate of 1 MHz, the measured 3dB bandwidth is 1.010 MHz. Therefore, this measurement can be used to determine gross errors in symbol rate.

2.3.1.2 Carrier frequency

Frequency errors can result in interference in the adjacent frequency channels. They can also cause problems in the carrier recovery process of the receiver. The designer must ensure that the transmitter is operating on the correct frequency. The carrier frequency should be located in the center of the spectrum for most modulation formats. It can be approximated by calculating the center of the 3dB bandwidth. For instance, in Figure 8, the measured carrier frequency is 850 MHz.

¹See Glossary for definition.

Figure 8.
Carrier frequency and channel
bandwidth measurements

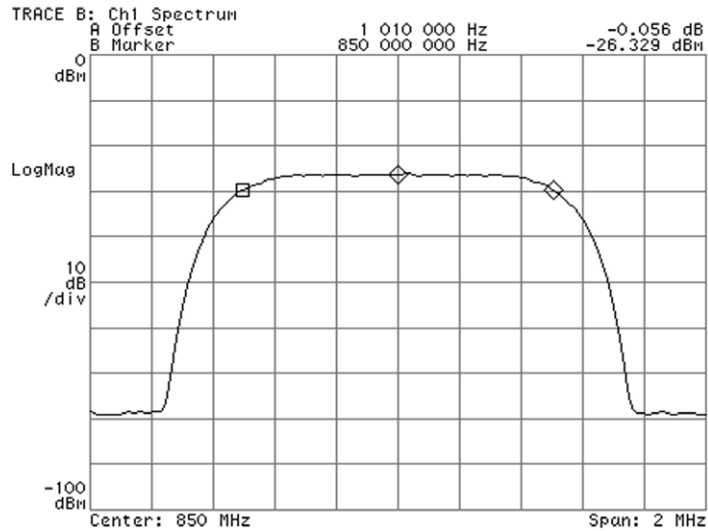

- Other common methods for determining the carrier frequency are:
- Measure an unmodulated carrier with a frequency counter.
 - Calculate the centroid of the occupied bandwidth measurement (see section 2.3.1.4). When performing an occupied bandwidth measurement, the testing instrument usually gives an indication of the frequency carrier error, as shown in Figure 10.
 - Use the frequency error metric given in the summary table when performing modulation quality measurements, as shown in Figure 15.

2.3.1.3 Channel power

Channel power is the average power in the frequency bandwidth of the signal of interest. The measurement is generally defined as power integrated over the frequency band of interest, but the actual measurement method depends on the standard followed [2] [3] [4].

Figure 9.
Channel power
measurement

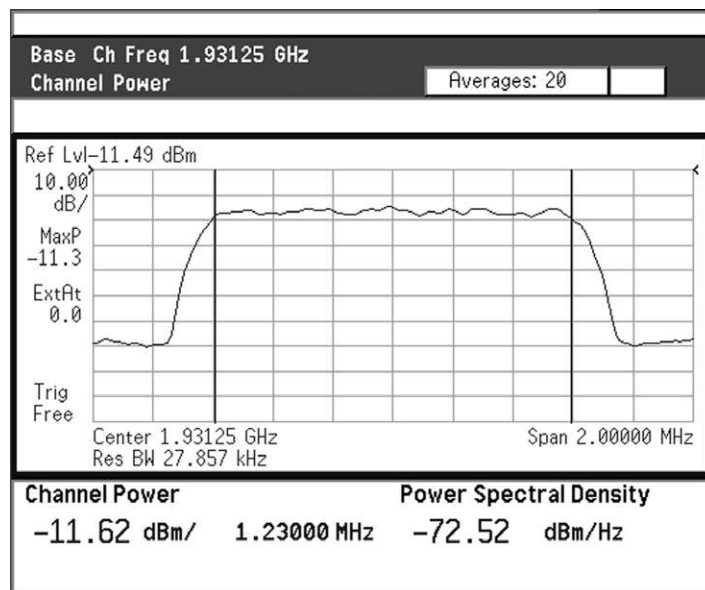

Power is the fundamental parameter of any communication system. The goal in wireless systems is to maintain each link sufficiently with minimum power. This gives two benefits: overall system interference is kept to a minimum and, in the case of mobile stations, battery life is maximized. Output power, therefore, is controlled within tight limits. If a transmitter produces too little power, link performance is compromised; too much, and interference with other transmitters may be too high and battery life too short.

In the case of CDMA systems, where total interference is a limiting factor for capacity, controlling the power of each mobile is also essential to achieve maximum capacity. Therefore, accurate control of the transmitted power is critical in defining a system's capacity, coverage and signal quality.

2.3.1.4 Occupied bandwidth

Occupied bandwidth is closely related to channel power. It indicates how much frequency spectrum is covered by some given percentage (often 99%) of the total power of the modulated signal. For instance, in Figure 10, the bandwidth that includes 99% of the power is 1.260 MHz. Any distortion (harmonic or inter-modulation) produces power outside the specified bandwidth.

Figure 10.
Occupied bandwidth measurement

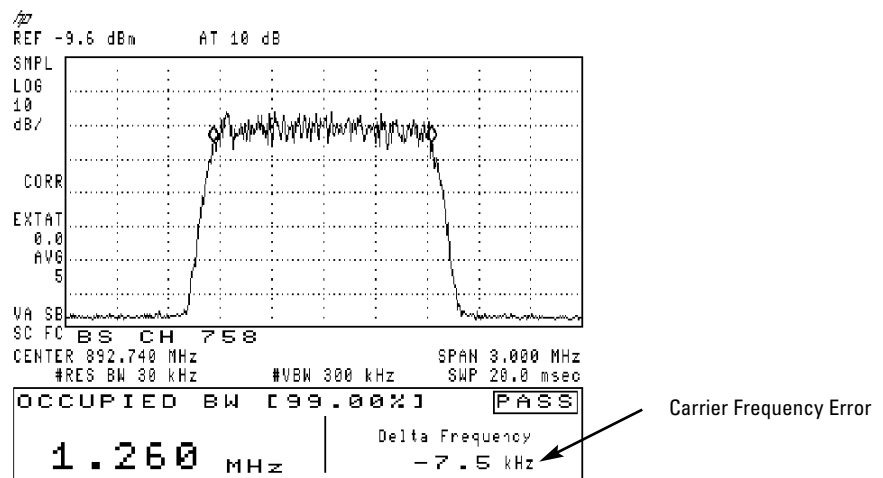

2.3.1.5 Peak-to-average power ratio and CCDF curves

Peak-to-average power ratio and CCDF (defined below) are statistical measurements on the time-domain waveform.

Peak-to-average power ratio is the ratio of the peak envelope power to the average envelope power of a signal during a given period of time.

Some instruments may provide peak-to-average power statistics; that is, the peak envelope power is given not as an absolute peak but rather as the power level associated with a certain probability. For example, in Figure 11 the measurement shows that the power is below a level that is 9.455 dB above the average 99.99% of the time; that is, there is a probability of .01% that the power of the signal is higher than a level 9.455dB above the average.

Figure 11.
Peak-to-average power ratio statistics

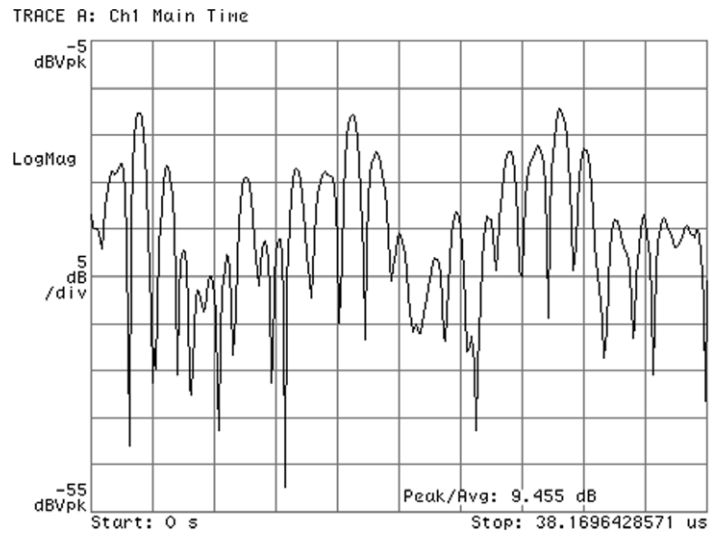

The power statistics of the signal can be completely characterized by performing several of these measurements and displaying the results in a graph known as the **Complementary Cumulative Distribution Function (CCDF)**. The CCDF curve shows the probability that the power is equal to or above a certain peak-to-average ratio, for different probabilities and peak-to-average ratios. The higher the peak-to-average power ratio, the lower the probability of reaching it.

Figure 12.
CCDF curves

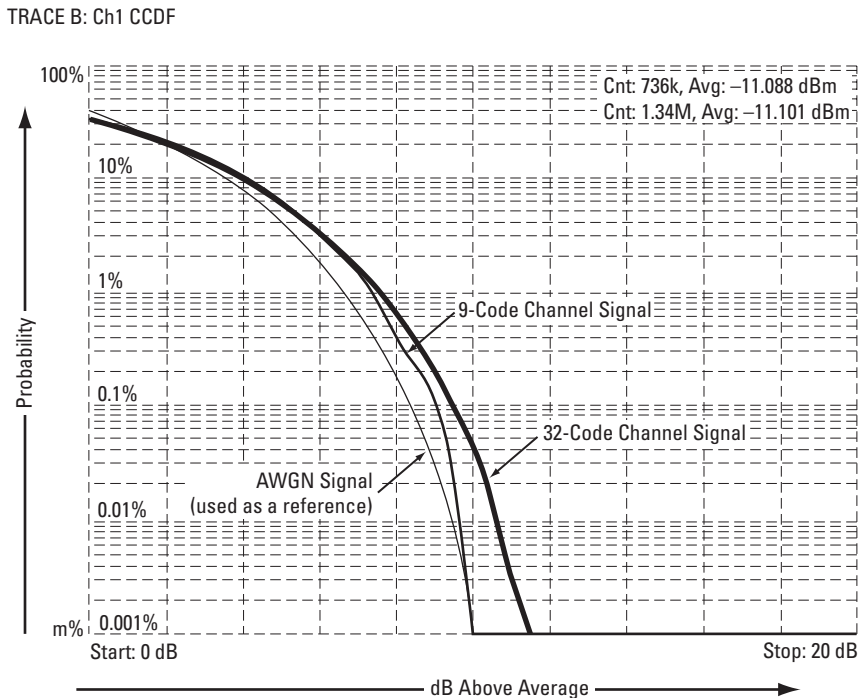

The statistics of the signal determine the headroom required in amplifiers and other components. Signals with different peak-to-average statistics can stress the components in a transmitter in different ways, causing different levels of distortion. CCDF measurements can be performed at different points in the transmitter to examine the statistics of the signal and the impact of the different sections on those statistics. These measurements can also be performed at the output of the transmitter to compare the statistics to an expected curve. CCDF curves are also related to Adjacent Channel Power (ACP) measurements, as we will see later.

Besides causing higher levels of distortion, high peak-to-average ratios can cause cumulative damage in some components. Performing CCDF measurements at different points of the transmitter can help you prevent this damage.

Peak-to-average power ratio and CCDF statistic measurements are particularly important in digitally-modulated systems because the statistics may vary. For instance, in CDMA systems, the statistics of the signal vary depending on how many code channels—and which ones—are present at the same time. Figure 12 shows the CCDF curves for signals with different code-channel configurations. The more code channels transmitted, the higher the probability of reaching a given peak-to-average ratio.

In systems that use constant-amplitude modulation schemes, such as GSM, the peak-to-average ratio of the signal is relevant if the components (for example, the power amplifier) must carry more than one carrier. There is a clear trend toward using multicarrier power amplifiers in base station designs for most digital communications systems. See [6] for more information on peak-to-average power ratio and CCDF curves.

2.3.1.6 Timing measurements

Timing measurements are common on TDMA systems, where the signal is bursted. The measurements assess the envelope of the carrier in the time domain against prescribed limits. Measurements include burst width, rise time, fall time, on-time, off-time, peak power, “on” power, “off” power and duty cycle.

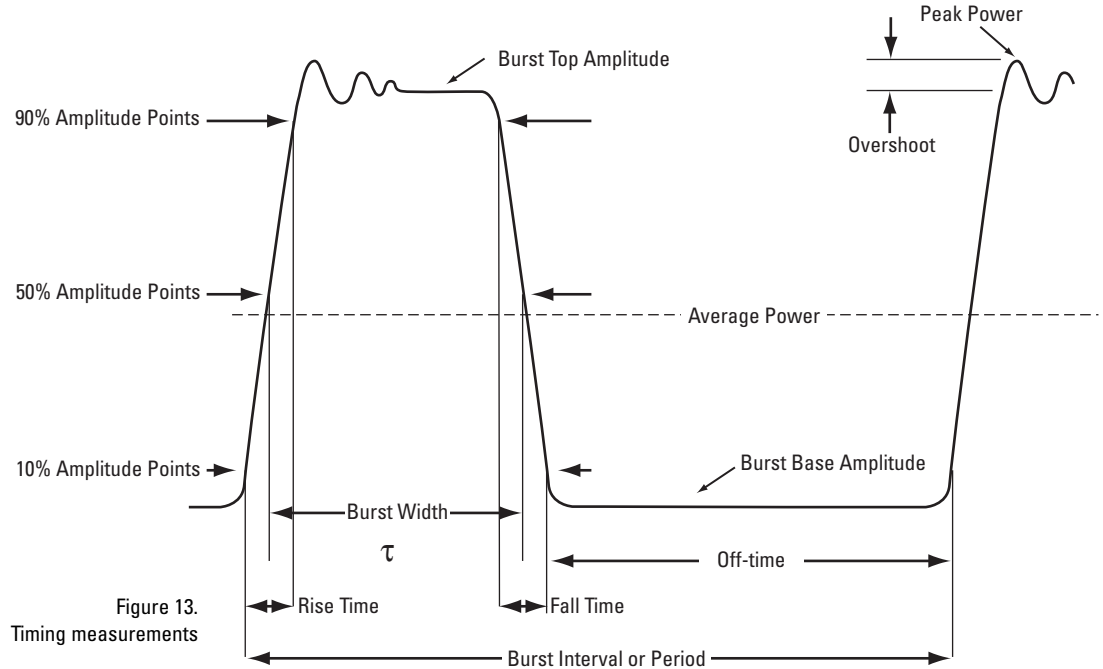

Figure 13.
Timing measurements

Timing measurements are mainly important to ensure minimum interference with adjacent frequency channels or timeslots during signal turn on and turn off. For instance, if the transmitter turns off too slowly, the user of the next timeslot in the TDMA frame experiences interference. If it turns off too quickly, the power spread into adjacent frequency channels increases [3] [4].

2.3.1.7 Modulation quality measurements

There are a number of different ways to measure the quality of a digitally modulated signal. They usually involve precision demodulation of the transmitted signal and comparison of this transmitted signal with a mathematically-generated ideal or reference signal, as we saw earlier. The definition of the actual measurement depends mainly on the modulation scheme and standard followed. NADC and PDC, for example, use Error Vector Magnitude (EVM), while GSM uses phase and frequency error. cdmaOne uses rho and code-domain power. These and other modulation quality measurements are described in the following sections.

2.3.1.7.1 Error Vector Magnitude (EVM)

The most widely used modulation quality metric in digital communications systems is **Error Vector Magnitude**. When performing EVM measurements, the analyzer samples the transmitter output to capture the actual signal trajectory. The signal is usually demodulated and a reference signal is mathematically derived. The **error vector** is the vector difference at a given time between the ideal reference signal and the measured signal. The error vector is a complex quantity that contains a magnitude and a phase component. It is important not to confuse the **magnitude of the error vector with the magnitude error**, or the **phase of the error vector with the phase error**. A graphical depiction of these differences can be seen in Figure 14.

Figure 14.
Error vector and related parameters

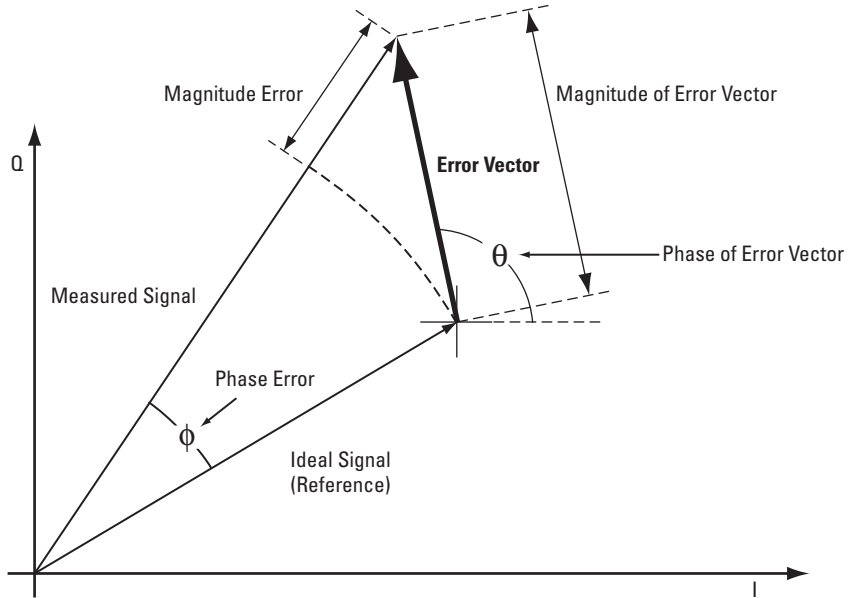

Error Vector Magnitude is the root-mean-square (rms) value of the error vector over time at the instants of the symbol clock transitions. By convention, EVM is usually normalized to either the amplitude of the outermost symbol or the square root of the average symbol power [4].

Apart from the constellation and polar diagrams, other important displays associated with EVM that are mentioned in this application note are **magnitude of the error vector versus time**, the spectrum of the error vector (**error vector spectrum**), **phase error versus time**, and **magnitude error versus time**. Figure 15 shows some of these displays.

Figure 15.
(a) Polar diagram
(b) magnitude of the error vector versus time
(c) error vector spectrum
(d) summary table and symbol table

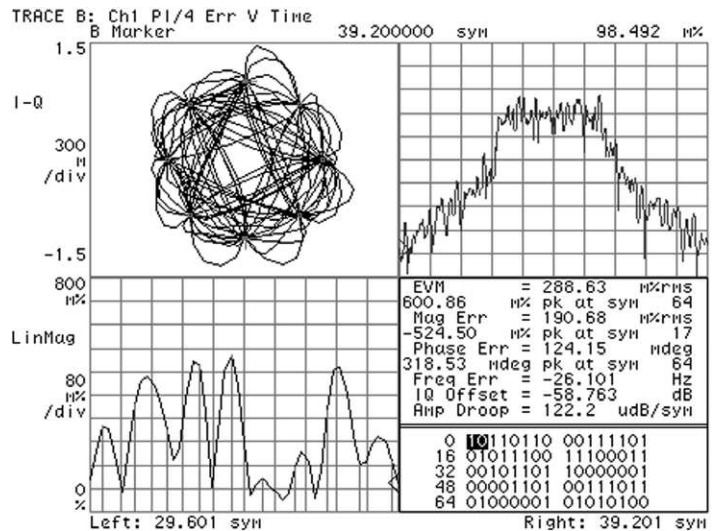

EVM and the various related displays are sensitive to any signal flaw that affects the magnitude and phase trajectory of a signal for any digital modulation format. Large error vectors both at the symbol points and at the transitions between symbols can be caused by problems at the baseband, IF or RF sections of the transmitter. As shown in the last chapter of this application note, the different modulation quality displays and tools can help reveal or troubleshoot various problems in the transmitter. For instance, the I/Q constellation can be used to easily identify I/Q gain imbalance errors. Small symbol rate errors can be easily identified by looking at the magnitude of the error vector versus time display. The error vector spectrum can help locate in-channel spurious.

The value of EVM as an indicator of modulation quality can be enhanced by the use of **equalization** in the measuring instrument. Equalization is commonly used in digital communications receivers. Although its primary function is to reduce the effects of multipath, it also compensates for certain signal imperfections generated in both the transmitter and receiver. For this reason, it is useful to have an equalizer in the measuring instrument. An instrument with an equalizer will better emulate a receiver; that is, the impairments that the equalizer of the receiver removes are also removed by the measuring instrument. Therefore, the impairments that have little effect on system performance also minimally impact the measured EVM. Figure 16 shows the magnitude of the error vector versus time with and without equalization. With equalization the constellation looks much better and the magnitude of the error vector versus time is lower. The signal has not changed, only the measurement technique.

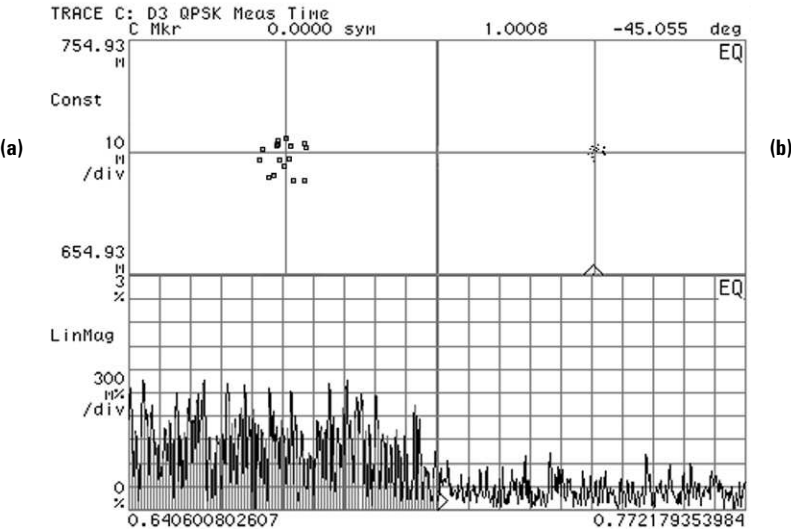
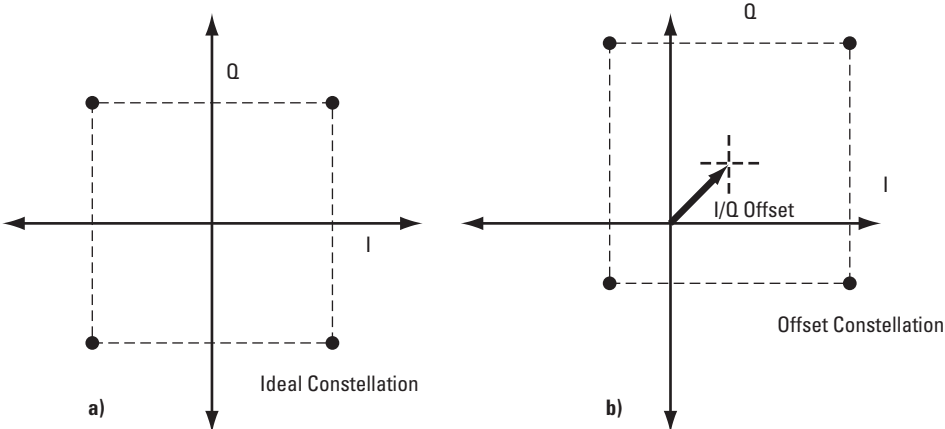

Figure 16. Constellation (zoomed) and magnitude of the error vector versus time (a) without equalization and (b) with equalization

2.3.1.7.2 I/Q offset. DC offsets at the I or the Q signals cause I/Q or origin offsets as shown in Figure 17. I/Q offsets result in carrier feedthrough. Some instruments compensate for this error before displaying the constellation or polar diagram and measuring EVM. In that case, I/Q offset is given as a separate error metric.

Figure 17.
(a) Ideal constellation versus
(b) offset constellation



2.3.1.7.3 Phase and frequency errors. For constant-amplitude modulation formats, such as GMSK used in GSM systems, the I/Q phase and frequency errors are more representative measures of the quality of the signal than EVM. As with EVM, the analyzer samples the transmitter output in order to capture the actual phase trajectory. This is then demodulated, and the ideal (or reference) phase trajectory is mathematically derived. The phase error is determined by comparing the actual and reference signals. The mean gradient of the phase error signal is the frequency error. The short-term variation of this signal is defined as phase error and is expressed in terms of rms and peak (see Figure 18).

Figure 18.
Phase and frequency error measurement

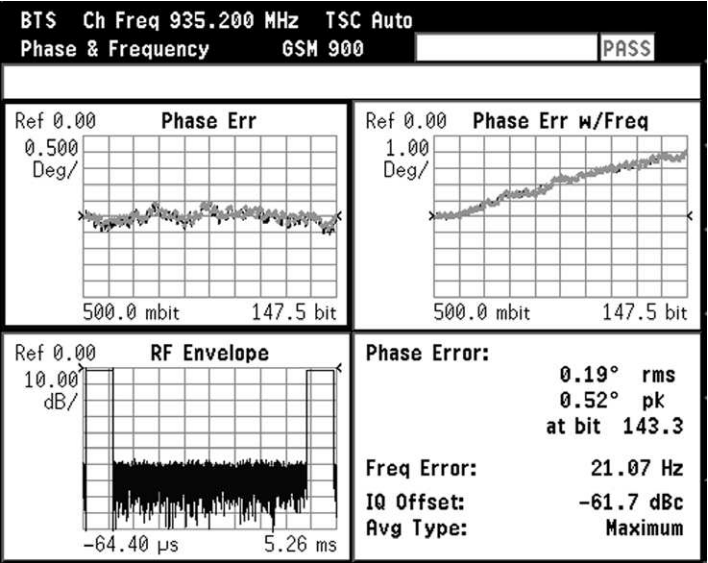

Significant phase errors can indicate problems in the baseband section of the transmitter. The output amplifier in the transmitter can also create distortion that causes unacceptably high phase error for multicarrier signals. Significant phase error at the beginning of a burst can indicate that a synthesizer is failing to settle quickly enough. In a real system, poor phase error reduces the ability of a receiver to correctly demodulate, especially with marginal signal conditions. This ultimately degrades sensitivity.

Frequency error is the difference between the specified carrier frequency and the actual carrier frequency. A stable frequency error simply indicates that a slightly wrong carrier frequency is being used. Unstable frequency errors can indicate short-term instability in the LO, improper filtering, AM-PM conversion in the amplifier, or wrong modulation index if the transmitter is implemented using an analog frequency modulator. See [3] for more information on phase and frequency error and other GSM measurements.

2.3.1.7.4 Frequency response and group delay. As noted above, equalization compensates for certain signal imperfections in the transmitter, transmission path or receiver. Equalization removes only linear distortion. Linear distortion occurs when the signal passes through one or more linear devices having transfer functions containing amplitude unflatness (for example, ripple and tilt), and/or group delay variations over the bandwidth of the signal. There can be many sources of linear distortion in a system: bandpass filters in the IF, improper cable terminations, improper baseband filtering, non-compensated $\sin(x)/x$, antenna mismatch, signal combiners and multipath signal effects. From a modeling standpoint, all of the linear distortion mechanisms can be combined and represented by a single transfer function, $H(f)$.

When applying equalization, the measuring instrument must counteract the effects of the linear distortion. To achieve that, an equalizer filter whose transfer function is $1/H(f)$ is applied over the bandwidth of the signal.

Once equalization has been applied, the inverse transfer function of the equalizer, which represents the linear distortion elements of the device under test, can be displayed and measured. If measured directly at the transmitter's output, the inverse transfer function is basically the bits-to-RF frequency response¹ of the transmitter (or the variations from the ideal frequency response caused by non-linear distortions) [7]. The actual frequency response can be displayed and measured as magnitude, phase, and group delay. Ideally, the magnitude of the frequency response should be flat across the frequency band of interest, and its phase should be linear over that same frequency band. Group delay is a more useful measure of phase distortion. It is defined as the derivative of the phase response versus frequency ($d\phi/d\omega$)—that is, the slope of the phase response. If the transmitter does not introduce distortion, its phase response is linear and group delay is constant. Deviations from constant group delay indicate distortion.

¹See Glossary for definition.

Figure 19.
 (a) Magnitude of the bits-to-RF frequency response should be flat across the frequency band of interest, indicated by (b) 3 dB bandwidth on signal spectrum

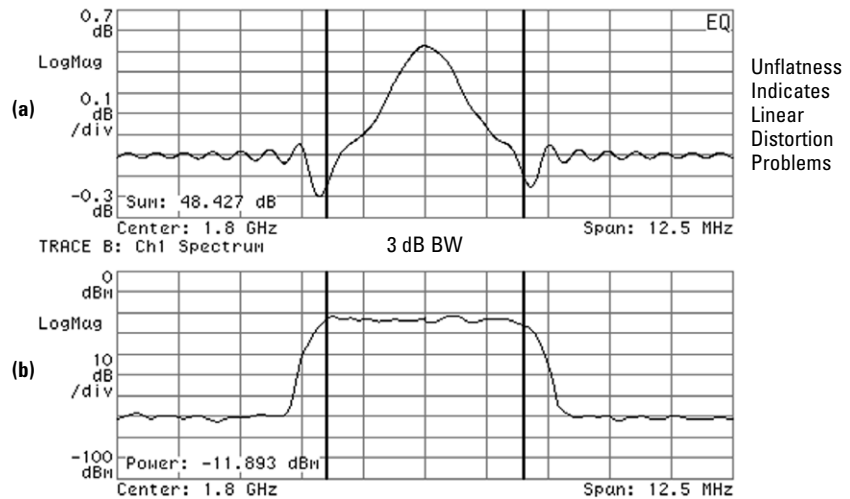

2.3.1.7.5 Rho. CDMA systems use ρ as one of the modulation quality metrics. Rho is measured on signals with a single code channel. It is the ratio of correlated power to total power transmitted (see Figure 20). The correlated power is computed by removing frequency, phase and time offsets, and performing a cross correlation between the corrected measured signal and the ideal reference. If some of the transmitted energy does not correlate, this excess power appears as added noise that may interfere with other users on the system.

Figure 20.
 Rho

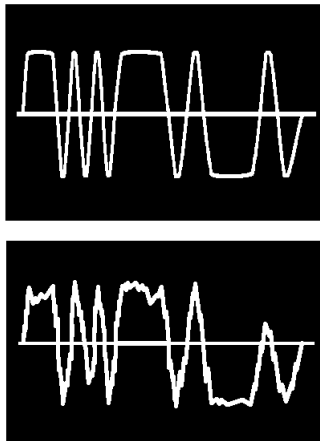

$$\rho = \frac{\text{Power that correlates with ideal}}{\text{Total Power}}$$

$$= \frac{\text{Signal Power}}{\text{Signal Power} + \text{Error Power}}$$

The rho measurement indicates the overall modulation performance level of a CDMA transmitter when transmitting a single channel. Since uncorrelated power appears as interference, poor rho performance affects the capacity of the cell [2].

2.3.1.7.6 Code-domain power. In CDMA systems, a signal with multiple code channels can be analyzed in the code domain. To analyze the composite waveform, each channel is decoded using a code-correlation algorithm. This algorithm determines the correlation coefficient factor for each code. Once the channels are decoded, the power in each code channel is determined [2].

Figure 21.
Code-domain power measurement

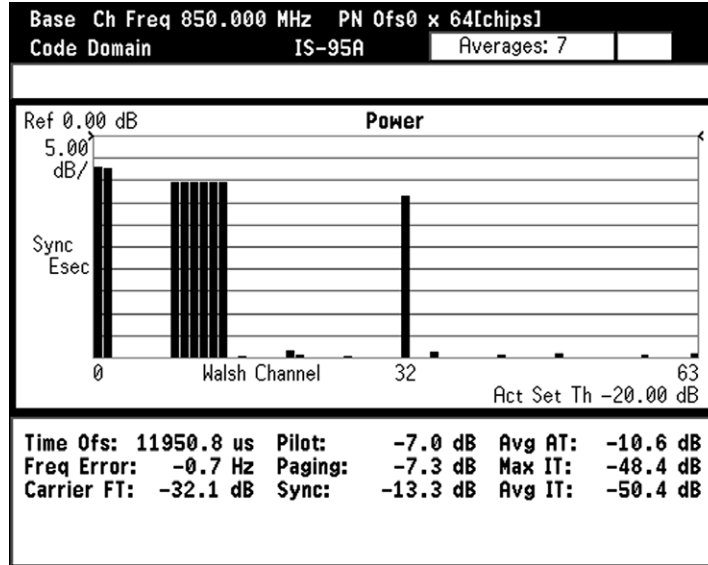

Measuring code-domain power, as shown in Figure 21, is essential for verifying that the base station is transmitting the correct power in each of the code channels. It is also important to look at the code-domain power levels of the inactive channels, which can indicate specific problems in the transmitter, as we will see in the last chapter of this application note. For instance, unwanted in-channel spurs raise the code-domain noise level. Compression can cause mixing of active code channels to produce energy in particular inactive channels.

2.3.2 Out-of-channel measurements

In-band out-of-channel measurements are those that measure distortion and interference within the system band, but outside of the transmitting frequency channel.

2.3.2.1 Adjacent Channel Power Ratio (ACPR)

Whatever the technology used or standard followed, ACP measurements are required to ensure that the transmitter is not interfering with adjacent and alternate channels.

The Adjacent Channel Power Ratio (ACPR) is usually defined as the ratio of the average power in the adjacent frequency channel to the average power in the transmitted frequency channel. For instance, in Figure 22, the ACPR across a bandwidth of 1MHz for both the transmitted and adjacent channels is -61.87 dB for the lower adjacent channel and -61.98 dB for the upper adjacent channel. The ACPR is often measured at multiple offsets (adjacent and alternate channels).

Figure 22.
ACPR measurement

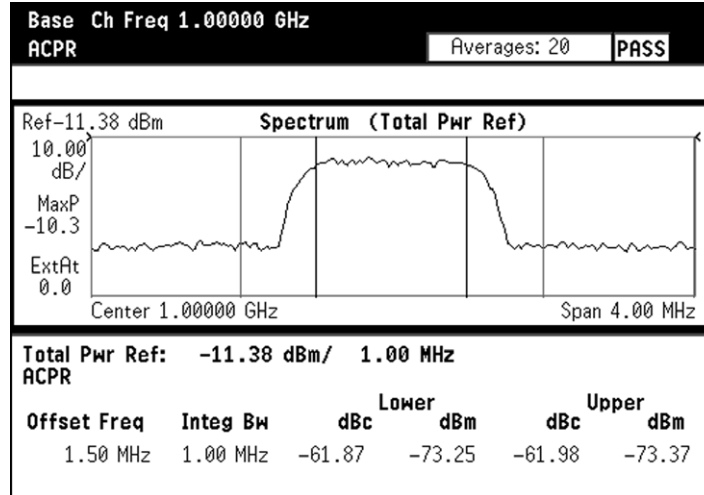

When making ACPR measurements, it is important to take into account the statistics of the signal transmitted. **CCDF** curves can be used for this purpose, as we saw earlier. Different peak-to-average ratio values have a different impact on the non-linear components of the transmitter, such as the RF amplifier, and therefore on the ACPR as well. Higher peak-to-average ratios in the transmitted signal can cause more interference in the adjacent channel. ACPR measurements on the same transmitter can provide different results depending on the statistics of the transmitted signal. When measuring ACPR in CDMA base stations, for example, it is important to consider the channel configuration used.

Different standards have different names and definitions for the ACP measurement. For example, for TDMA systems such as GSM, there are two main contributors to the ACP: the burst-on and -off transitions, and the modulation itself. The GSM standards name the ACP measurement **Output RF Spectrum (ORFS)** and specify two different measurements: **ORFS due to modulation** and **ORFS due to switching [3]**.

In the case of NADC-TDMA, the ACP due to the transients and the modulation itself are also measured separately for mobile stations. Additionally, a weighting function that corresponds to the receiver baseband filter response is applied to the measurement for both base and mobile stations [4].

Spectral splatter is a term often associated with the ACP due to transients. Spectral splatter can be caused by fast burst turn-on and turn-off, clipping (saturation) and Digital Signal Processor (DSP) glitches or other errors due to scaling. High spectral splatter may occasionally be caused by phase transients. Since transients are very short events, time capture can be useful to locate and analyze them. Spectral splatter can also be analyzed using a spectrogram, which displays spectrum versus time, as shown in Figure 74 (section 3.2.11).

For cdmaOne systems, the ACPR is not defined in the standard, but it is often used in practice to test the specified in-band spurious emissions [2].

Spectral regrowth is a measure of how much the power in the adjacent channel grows (how much worse it gets) for a specific increment of the transmitted channel power.

2.3.2.2 Spurious

Spurious signals can be caused by different combinations of signals in the transmitter. The spurious emissions from the transmitter that fall within the system’s band should be below the level specified by the standard to guarantee minimum interference with other frequency channels in the system (see Figure 23) [2] [3].

Figure 23. In-band spurious measurement

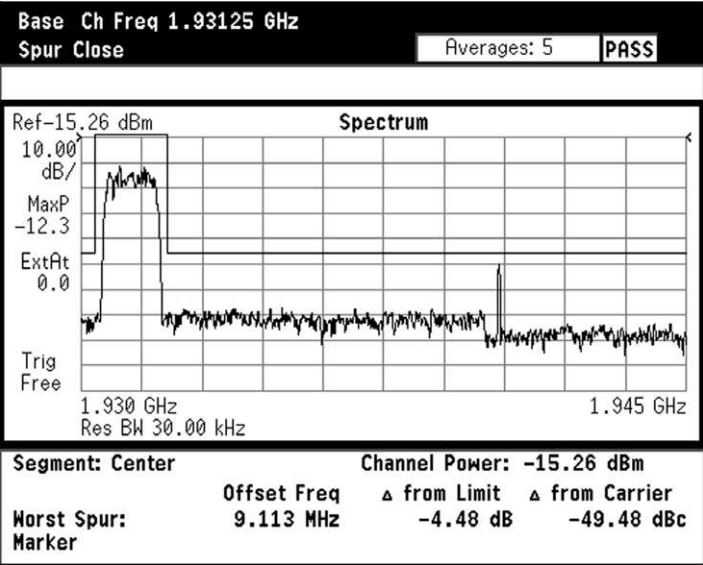

2.4 Out-of-band measurements

Out-of-band measurements are those outside the system frequency band.

2.4.1 Spurious and harmonics

While spurious are caused by different combinations of signals in the transmitter, harmonics are distortion products caused by nonlinear behavior in the transmitter. They are integer multiples of the transmitted signal’s carrier frequency.

Out-of-band spurious and harmonics are measured to ensure minimum interference with other communications systems (Figure 24) [2] [3].

Figure 24.
Out-of-band spurious and
harmonics measurement

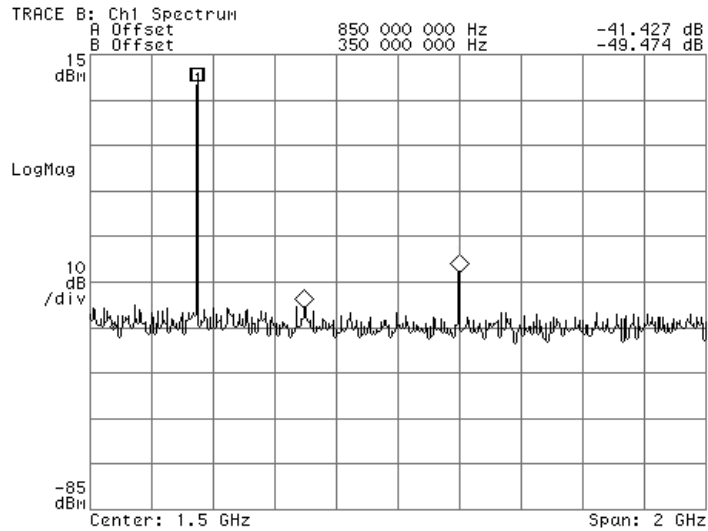

2.5 Best practices in conducting transmitter performance tests

By following certain guidelines in conducting design verification tests, you can greatly increase the probability that the transmitter will operate properly in the real-world environment. The test equipment should be carefully chosen to reduce measurement uncertainties and increase confidence in correct transmitter operation.

When performing absolute power measurements, such as channel power, the accuracy of the measurement is limited by the absolute amplitude accuracy of the instrument. In the case of relative power measurements, such as ACPR, the accuracy is limited by the relative amplitude accuracy and dynamic range of the instrument. As a rule of thumb, the noise floor or distortion of the instrument should be at least 10 dB below the distortion of the signal being measured.

Since the signal is noise-like, averaging the power over several measurements is extremely important for more repeatable power measurements [8].

In the case of timing measurements, the accuracy of the measurement is mainly limited by the time accuracy, time resolution, and amplitude linearity of the instrument. Since there are a number of parameters to measure, the use of masks and pass/fail messages makes it simpler to ensure that all the timing parameters meet their specifications.

The accuracy of modulation quality measurements is mainly limited by the accuracy of the test instrument, which is usually given as a percentage. Typically, the test equipment should be ten times more accurate than the specified limit so measurement results can be attributed to the unit-under-test (UUT) and not to the measuring instrument.

3. Troubleshooting Transmitter Designs

Transmitter designs are tested to ensure conformance with a particular standard and are typically performed at the antenna port. However, substandard performance may be caused by various parts of the system, so troubleshooting is usually done at several points in the transmitter. The source of impairments can be difficult to determine. This difficulty is magnified by these practicalities:

- Part of the transmitter is generally implemented digitally.
- Some parts of the transmitter may not be accessible.
- It may be unclear whether a problem is rooted in the analog or digital section of the system.

The ability to look at the signal and deduce the source of a problem is very important to successful design. The ideal troubleshooting instrument has the flexibility and measurement capabilities to help you infer problem causes from measurements at the RF, IF and baseband sections of the transmitter.

The measurements described in this chapter are performed at the antenna port, assuming that other parts of the transmitter are not easily accessed. The objective is to help you recognize and troubleshoot the most common impairments from measurements performed at the antenna port. To assist you in this task, the following information is included in this chapter:

- A general troubleshooting procedure (see Appendix A for a more detailed procedure).
- A table that links measurement problems to their possible causes in the different sections of the transmitter.
- A description of the most common impairments, and an explanation of how to verify each one of them.

3.1 Troubleshooting procedure

The following is a suggested troubleshooting procedure to follow if the transmitter design does not meet the specifications:

1. Look at the signal in the frequency domain and verify that its spectrum appears as expected. Ensure that its center frequency and bandwidth are correct.
2. Perform in-band and out-of-band power measurements: channel power, ACP (check CCDF curve), spurious and harmonics.
3. In the case of bursted signals, perform timing measurements.
4. Look at the constellation of the baseband signal.
5. Examine error metrics (EVM, I/Q offsets, phase error, frequency error, magnitude error and rho).
6. If the phase error is significantly larger than the magnitude error, examine I/Q phase error versus time. Perform phase noise measurements on LOs, if accessible.
7. If phase error and magnitude error are comparable, examine magnitude of the error vector versus time and error vector spectrum.
8. Turn the equalizer on and verify that it reduces modulation quality errors, and check frequency response and group delay of the transmitter for faulty baseband or IF filtering or other linear distortion problems.

In these measurements, variations from the expected results will help you locate faults in different parts of the transmitter. The following sections describe the most common impairments and how to recognize them from their effects on the different measurements.

Refer to Appendix A for a more detailed troubleshooting procedure.

3.2 Impairments

Table 1 will help you identify the most common impairments that might be affecting a specific measurement when you are testing your design.

		Impairments										
		Compression	I/Q Error	Symbol Rate	Wrong Filter Coefficients or Windowing	Wrong Interpolation	IF Filter Tilt or Ripple	LO Instability	Interfering Tone	AM-PM Conversion	DAC/DSP Error	Burst-Shaping Error
Measurements Affected	Channel BW			●	●	●	●				●	
	Channel Power			○	○	○	○				○	○
	CCDF	●	○		●	●	●		○		●	
	ACP	●		○	●	●		●			●	●
	Spurious								●			
	Timing										○	●
	EVM (or Phase Error)	●	●	●	●	●	●	●	●	●	●	●
	Code-Domain Power (or rho)	●	●	●	●	●	●	●	●	●	●	
	Bits-to-RF Frequency Response (& Group Delay)				●	●	●				●	

● High probability that impairment affects the measurement

○ Severe cases of impairment may affect the measurement

For instance, a high level of ACP is probably caused by one of the following impairments:

- Compression at the amplifier
- Wrong filter coefficient or incorrect windowing at the baseband filter.
- Incorrect interpolation.
- LO instability.
- Burst-shaping error.
- DAC/DSP error.
- A severe case of symbol rate error.

You can further analyze and verify if any of these impairments is present by following the directions given in the following sections.

3.2.1 Compression

Figure 25.
Power amplifier

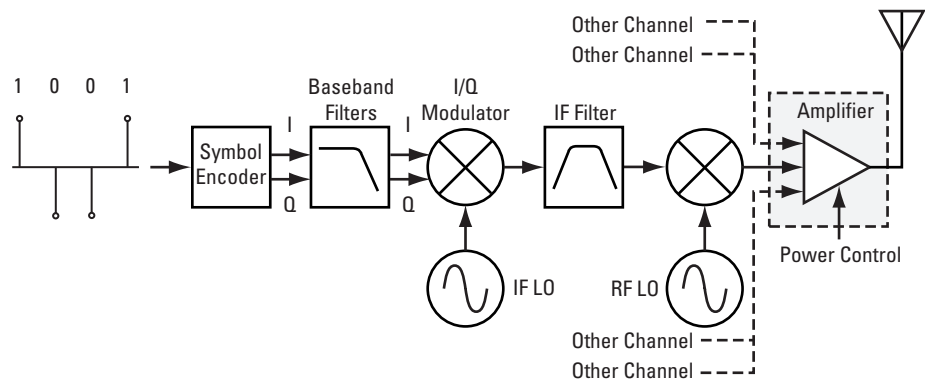

The power amplifier (PA) is the final stage prior to transmission. Key characteristics of the PA are frequency and amplitude response, -1dB compression point and distortion. The PA selected must be appropriate for the signal type. To avoid compression of the signal, the input levels and output section gains in the amplifier must be tightly controlled.

Compression occurs when the instantaneous power levels are too high, driving the amplifier into saturation. For instance, if the signal peak power is not properly taken into account, signal compression can occur. This issue is particularly relevant to CDMA systems, because the peak-to-average ratio of the multi-code signal changes depending on the channel configuration. Mobile station transmitters that use constant-amplitude modulation schemes (like GSM mobile station transmitters), which only carry information on the phase of the signal, are more efficient when slightly saturated. But in other digitally-modulated systems, compression causes clipping and distortion, which may result in a loss of signal transmission efficiency and cause interference with other channels.

How can you verify compression?

The best way to verify that the signal is compressed is to make ACPR and CCDF measurements before and after the amplifier and compare the results. If measurements in front of the amplifier are not possible, you can lower the amplitude of the transmitted signal and compare measurement results. In the case of ACPR, if the peak amplitude of the transmitted signal drives the amplifier into compression, distortion occurs, and the distortion in adjacent frequency channels is larger than expected. Therefore, the measured ACPR is smaller.

Figure 26.
ACP increases when compression occurs

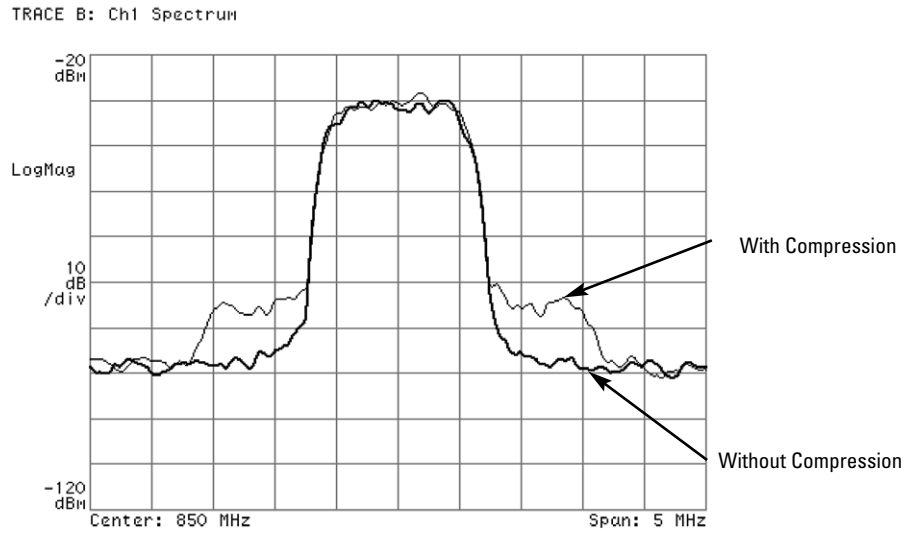

In the case of peak-to-average ratio and CCDF statistics, if compression occurs, the peak levels of the transmitted signal are clipped. Clipping causes a peak-to-average ratio reduction. Therefore, the CCDF curve shows lower probabilities of reaching large peak-to-average ratios—that is, the peak-to-average ratio is smaller for a certain probability, as shown in Figure 27.

Figure 27.
CCDF curves for signal with and without compression

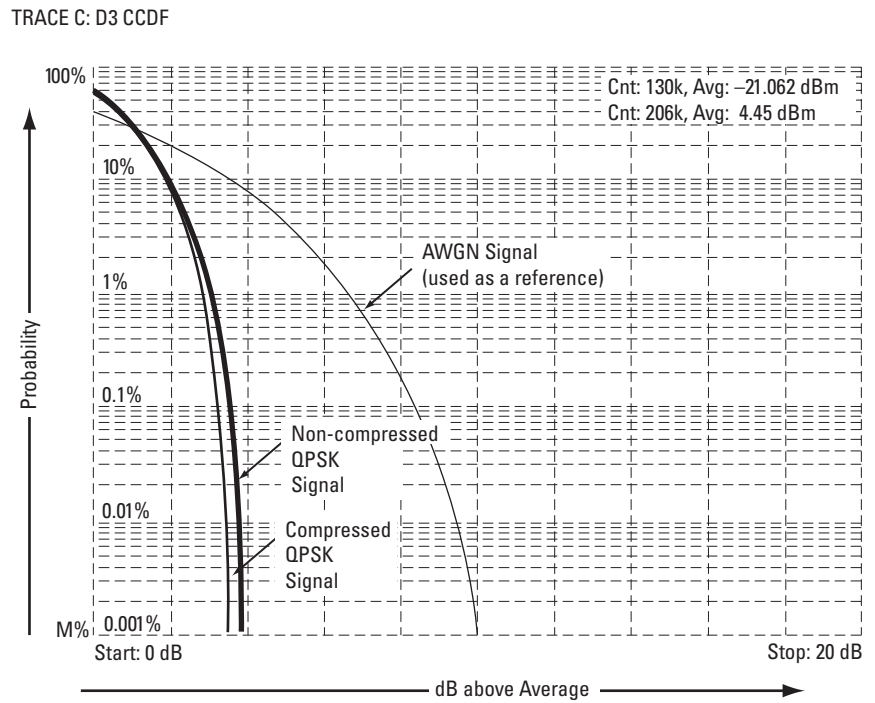

Compression may also be detected in other measurements:

- Polar diagram.** If the high peak levels of the transmitted signal are clipped, the signal has a lower overshoot. This effect can be seen by comparing the trajectory of the compressed signal to the ideal trajectory in the polar diagram, as in Figure 28. Filtering at the receiver causes dispersion in time. In practice, compression often causes an error in the symbol(s) after a peak excursion of the signal. Therefore, EVM may be affected.

Figure 28. Polar diagram of compressed signal (compared to ideal trajectory)

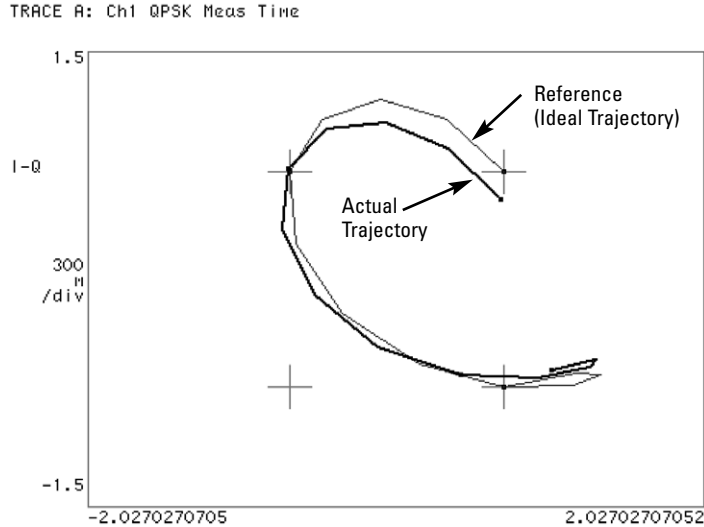

- Code-domain power.** Non-linearity in the amplifier also causes an increase in the code-domain noise level in CDMA systems. Compression causes code-domain mixing. Therefore, energy appears in the non-active channels in deterministic ways. For instance, in Figure 29, for a cdmaOne signal, Walsh code 1 mixes with Walsh codes 12 and 32, causing energy to show up on Walsh codes 13 and 33. Also, Walsh code 12 mixes with Walsh code 32 to create power on Walsh code 44.

Figure 29. Code-domain power for (a) non-compressed signal versus (b) compressed signal

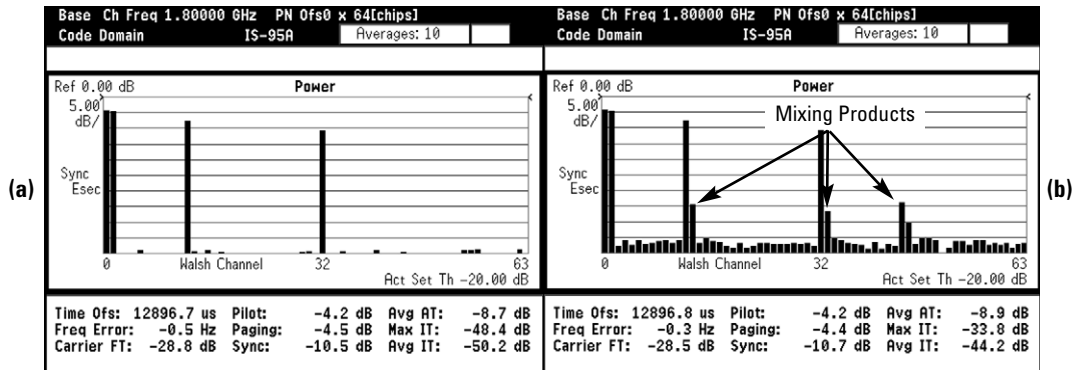

Compression is not a linear error and cannot be removed by equalization.

¹ See Glossary for definition.

I/Q Impairments

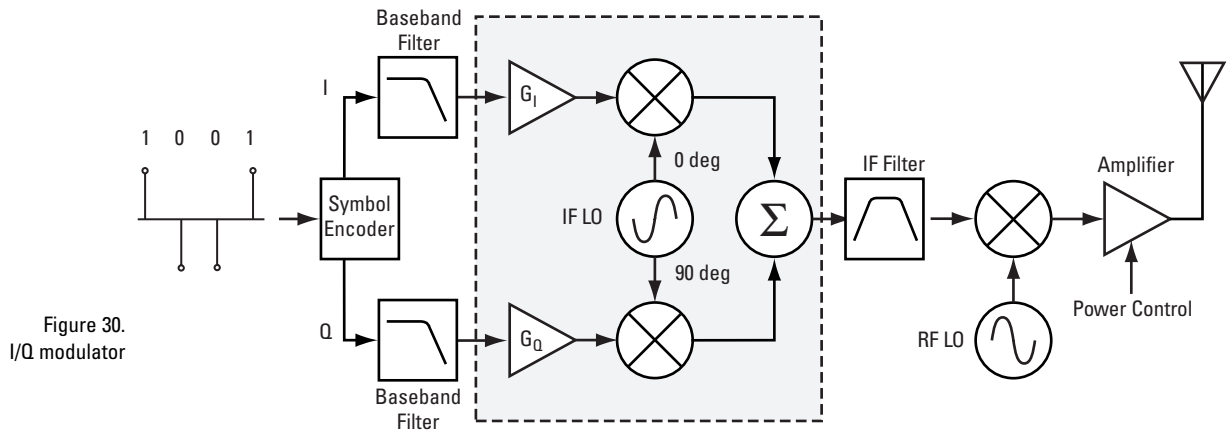

Figure 30.
I/Q modulator

I/Q impairments can be caused by matching problems due to component differences between the I side and Q side of a network. The most common I/Q impairments are listed below:

1. **I/Q gain imbalance.** Since I and Q are two separate signals, each one is created and amplified independently. Inequality of this gain between the I and Q paths results in incorrect positioning of each symbol in the constellation, causing errors in recovering the data (see Figure 31). This problem is rare in systems where the IF is implemented digitally.

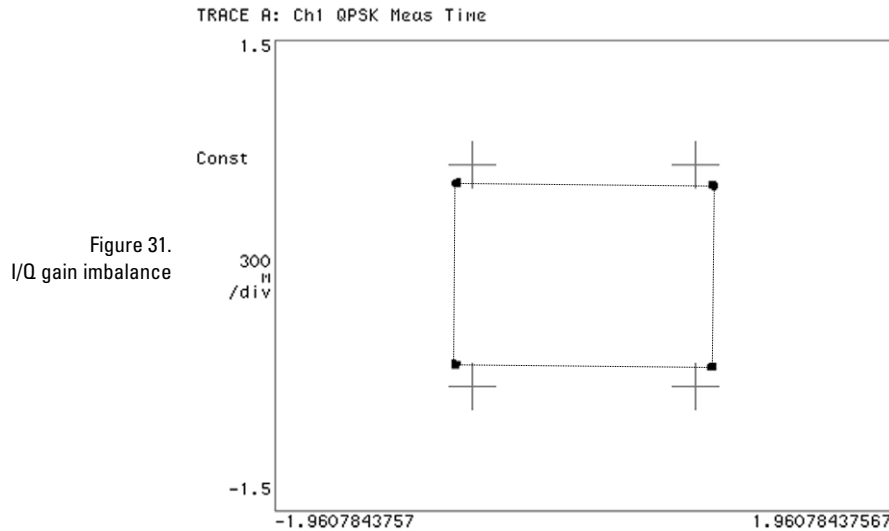
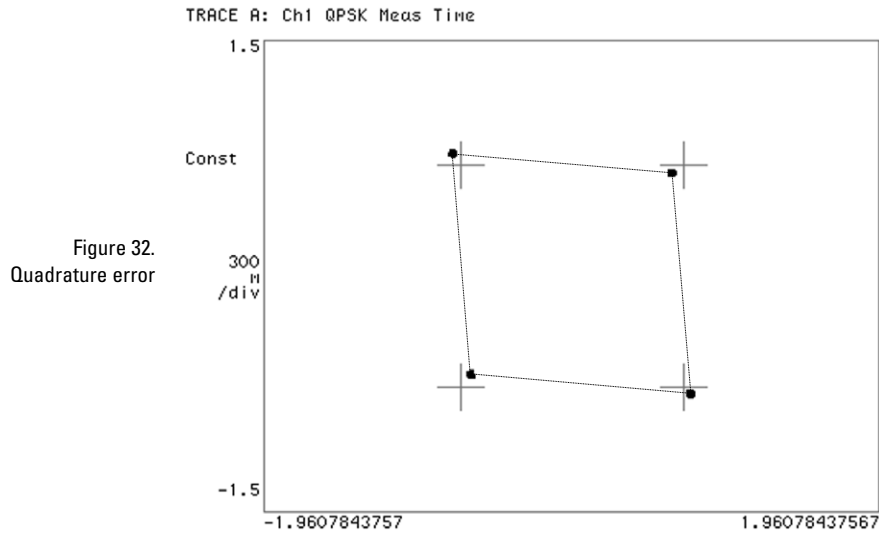
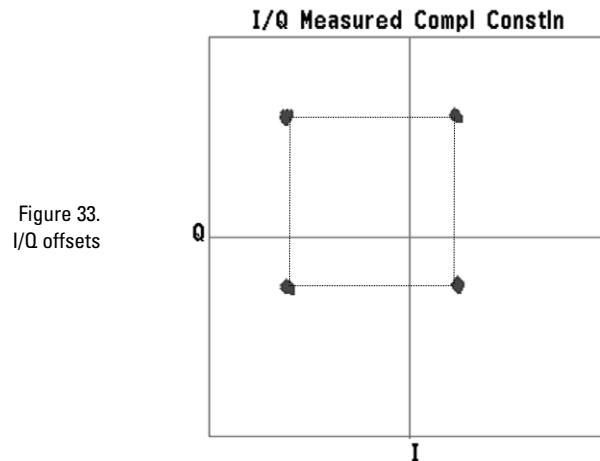

Figure 31.
I/Q gain imbalance

2. **Quadrature errors.** If the phase shift between the IF (or RF) LO signals that mix with the I and Q baseband signal at the modulator is not 90 degrees, a quadrature error occurs. The constellation of the signal is distorted (see Figure 32), which may cause error in the interpretation of the recovered symbols.



3. **I/Q offsets.** DC offsets may be introduced in the I and Q paths. They may be added in the amplifiers in the I and Q paths. For digital IF implementations, offsets may also occur from rounding errors in the DSP. See Figure 33.



4. **Delays in the I or Q paths.** When the serial bit stream is encoded into symbols and the bits are split into parallel paths for creation of the I and Q signals, it is important that these signals are properly aligned. Problems in this process can cause unwanted delays between the I and Q signals. Delays can be caused by the modulator or by the previous components in the I or Q paths (for example, the baseband filter or the DAC). For instance, if the baseband filters are analog, variations in group delay between the filters cause different delays in the I and Q paths. Different electrical lengths in the I and Q paths may also cause significant delay differences between the two paths, especially for signals with wide bandwidths (high symbol rates). Refer to Figure 34.

Figure 34.
Q delayed relative to I

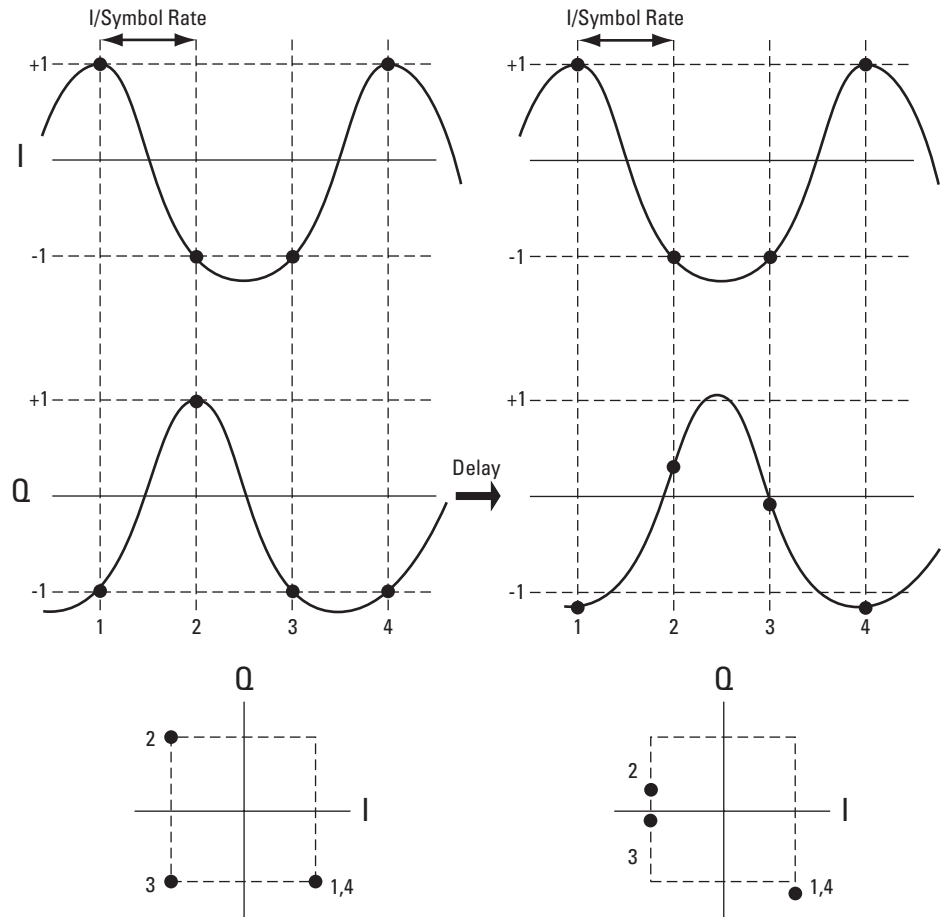

5. **I/Q swapped.** Swapping the I and Q signals reverses the phase trajectory and inverts the spectrum around the carrier. Therefore, swapping the I and Q or changing the sign of the shift (+90 or -90 degrees) makes a difference in the signal transmitted: $\cos(\omega L t) - j\sin(\omega L t)$ versus $\cos(\omega L t) + j\sin(\omega L t)$. The mapping of the IF I and Q signals is reversed, which causes symbol errors, as seen in Figure 35.

Figure 35.
I/Q swapped

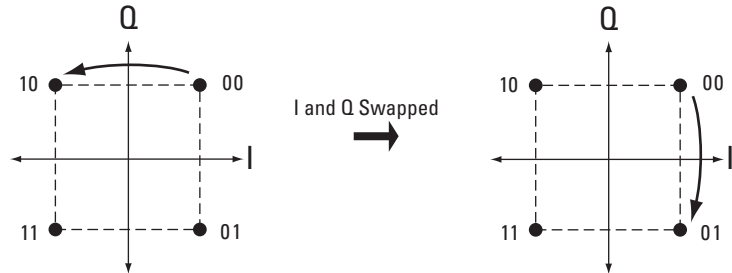

How can you verify the different I/Q impairments?

The best way to verify most I/Q impairments is to look at the **constellation** and **EVM metrics**.

I/Q gain imbalance results in an asymmetric constellation, as seen in Figure 31. **Quadrature errors** result in a “tipped” or skewed constellation, as seen in Figure 32. For both errors the constellation may tumble randomly on the screen. This effect is caused by the fact that the measuring instrument decides the phases for I and Q periodically, based on the data measured, and arbitrarily assigns the phases to I or Q. Using an appropriate sync word as a trigger reference makes the constellation stable on the screen, permitting the correct orientation of the symbol states to be determined. Therefore, the relative gains of I and Q can be found for gain imbalance impairments, and the phase shift sign between I and Q can be determined for quadrature errors.

I/Q offset errors may be compensated by the measuring instrument when calculating the reference. In this case, they appear as an I/Q offset metric. Otherwise, I/Q offset errors result in a constellation whose center is offset from the reference center, as seen in Figure 33. The constellation may tumble randomly on the screen unless a sync word is used as a trigger, for the same reason indicated above.

Delays in the I or Q paths also distort the measured constellation. However, if the delay is an integer number of samples, the final encoded symbols transmitted appear positioned correctly but are incorrect. The error cannot be detected unless a known sequence is measured. Mathematical functions in the measuring instrument can help compensate for delays between I and Q, by allowing you to introduce delays in the I or Q paths. In this way, you can confirm and measure the delay.

For any of these errors, magnifying the scale of the constellation can help detect subtle imbalances visually. Since the constellation is affected, these errors deteriorate EVM.

I/Q swapped results in an inverted spectrum. However, because of the noise-like shape of digitally-modulated signals, the inversion is usually undetectable in the frequency domain. In the modulation domain, the data mapping is inverted, as seen in Figure 35, but the error cannot be detected, unless a known sequence is measured. In CDMA signals, I/Q swapping errors can be detected by looking at the code-domain power display. Since these errors result in an incorrect transmitted symbol sequence, the measuring instrument can no longer find correlation to the codes. This causes an unlock condition, in which the correlated power is randomly distributed among all code-channels, as shown in Figure 36. Some vector signal analyzers have an inverted frequency mode that accounts for this error and allows you verify it.

Figure 36.
 (a) Normal versus
 (b) unlock condition for
 code-domain power
 (power randomly
 distributed among
 all code-channels)

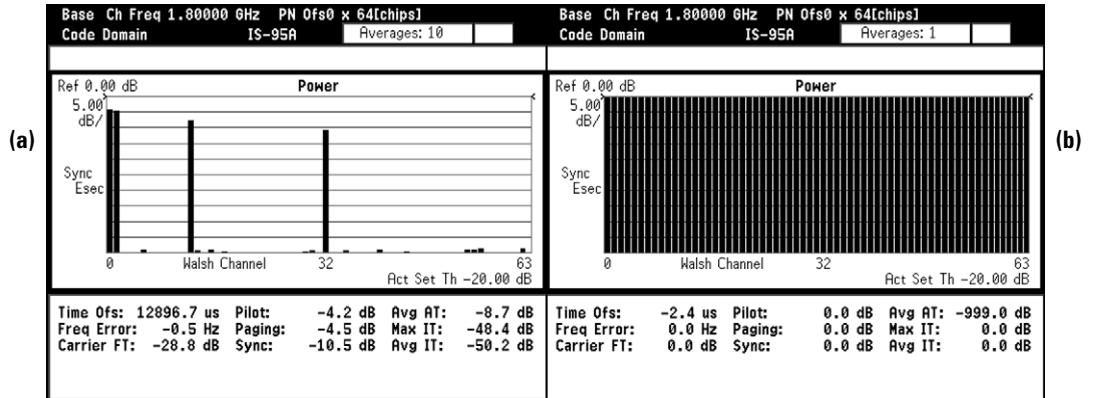

Code-domain power is affected by any I/Q impairment. Basically, any impairment that degrades EVM will cause an increase in the code-domain-power noise floor—that is, an increase in the level of non-active channels. Figure 37 shows an increase in the code-domain-power noise floor for a cdmaOne system with an I/Q gain imbalance of 3 dB.

Figure 37.
 Increase in
 code-domain-power
 noise floor
 (right versus left)

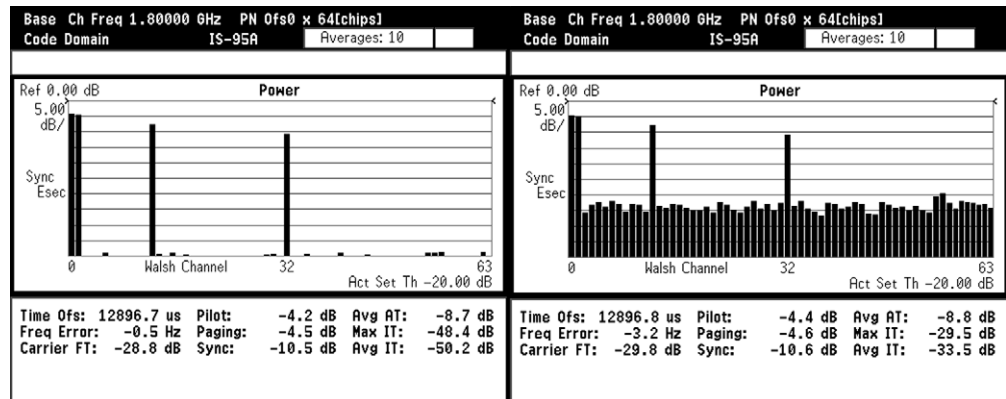

I/Q impairments are not linear errors and therefore cannot be removed by applying equalization.

3.2.3 Incorrect symbol rate

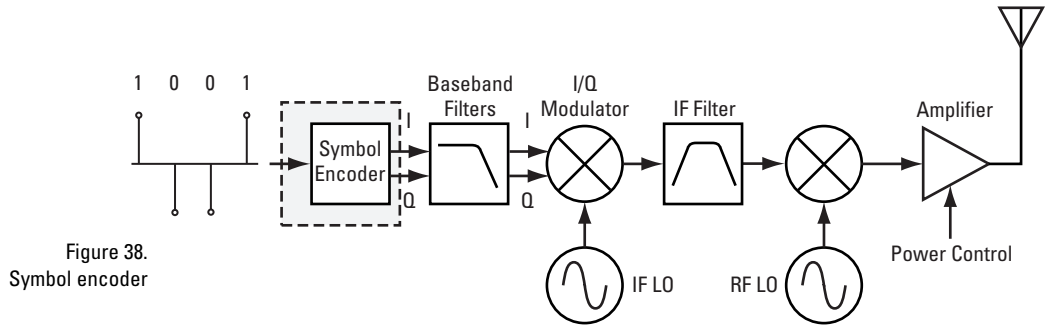

Figure 38.
Symbol encoder

The symbol clock of a digital receiver system dictates the sampling rate of the baseband I and Q waveforms. To accurately interpret the symbols and recover the digital data at the receiver, it is imperative that the transmitter and the receiver have the same symbol rate.

The symbol clock in the transmitter must be set correctly. Symbol rate errors often occur from using the wrong crystal frequency (for example, if two numbers are swapped in the frequency specification). Slight errors in the clock frequency impair the signal slightly, but as the frequency error increases the signal can become unusable. Therefore, it is important to be able to verify errors in the symbol timing.

How can you verify errors in the symbol rate?

The effect of symbol rate errors on the different measurements depends on the magnitude of the error. If the error is large enough, the instrument cannot demodulate the signal correctly and modulation quality measurements are meaningless. For instance, for a QPSK system with a specified symbol rate of 1 MHz, an error of 10 kHz (actual symbol rate of 1.010 MHz) can cause an unlock condition when looking at the constellation and measuring EVM. For a W-CDMA system with a specified symbol rate of 4.096MHz, an error of 200Hz (actual symbol rate of 4.0962) causes an unlock condition in the code-domain power measurement.

Therefore, the methods to verify small symbol errors (those that do not cause an unlock condition) and large symbol errors (those that create an unlock condition) are different.

Small errors

The best way to verify small errors in the symbol rate is by looking at the **magnitude of the error vector versus time** display. If the symbol rate is slightly off, this display shows a characteristic 'V' shape, as in Figure 39b.

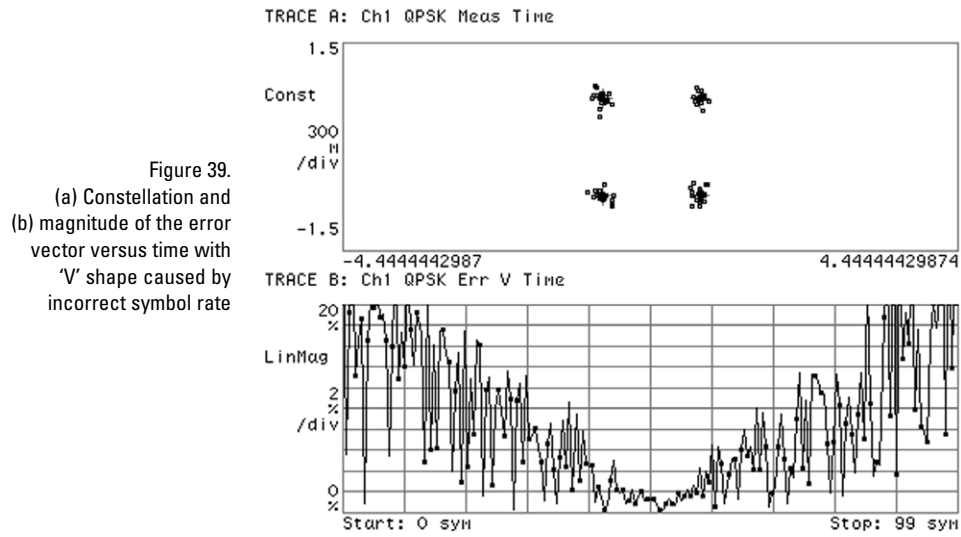

This effect can be understood by studying Figure 40. For simplicity, a sinewave is used instead of a digitally-modulated signal, and its frequency (symbol rate) is slightly higher than the specified sample frequency (symbol rate chosen in the measuring instrument). At one arbitrary reference sample (called 0) the signal will be sampled correctly. Since the symbol rate is slightly off, any other sample in the positive or negative direction will be slightly off in time. Therefore, the signal will deviate by some amount from the perfect reference signal. This deviation or error vector grows linearly (on average) in both the positive and negative directions. Therefore, the magnitude of the error vector versus time shows a characteristic 'V' shape.

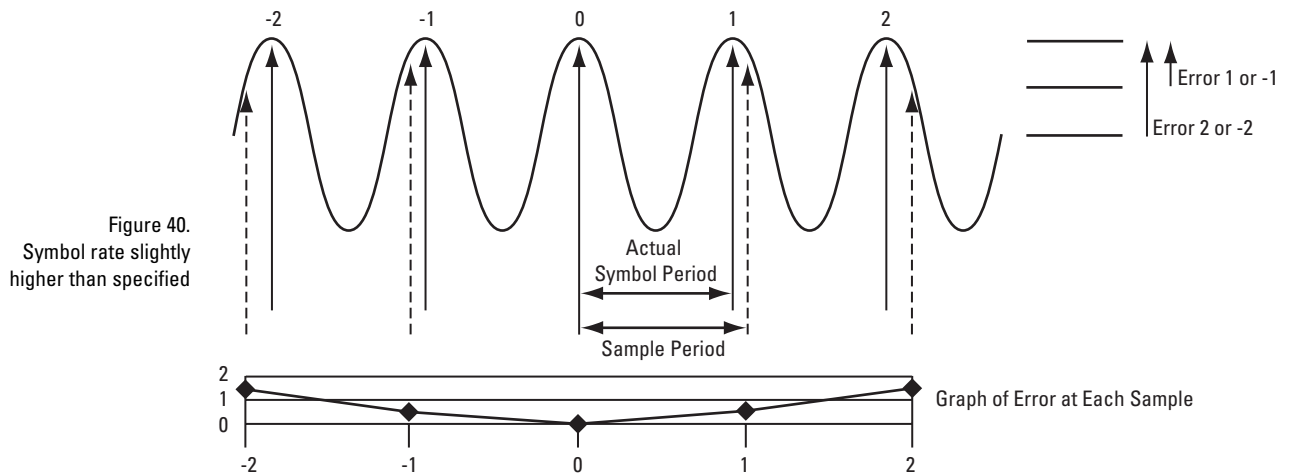

The smaller the symbol rate error, the more symbols are required to detect the error (that is, to form the 'V' shape). For instance, in Figure 39b, for a QPSK system with a symbol rate specified at 1MHz, 100 symbols are measured to form a "V" shape in the magnitude of the error vector versus time display for an actual symbol rate of 1.0025 MHz. In the same case, about 500 symbols are required to form a similar 'V' shape for an actual symbol rate of 1.00025 MHz.

The actual transmitted symbol rate can be found by adjusting the symbol rate in the measuring instrument by trial and error until magnitude of the error vector versus time looks flat.

Small symbol errors also affect the **code-domain power** measurement. The code-domain power noise floor increases proportionally to the magnitude of the error.

Large errors

The best way to verify large symbol rate errors that produce unlock conditions in the measurements is by measuring the signal's **channel bandwidth** to roughly approximate the symbol rate, as explained in section 2.3.1.1.

Errors in the symbol rate are not linear and cannot be minimized by applying equalization.

3.2.4 Wrong filter coefficients and incorrect windowing

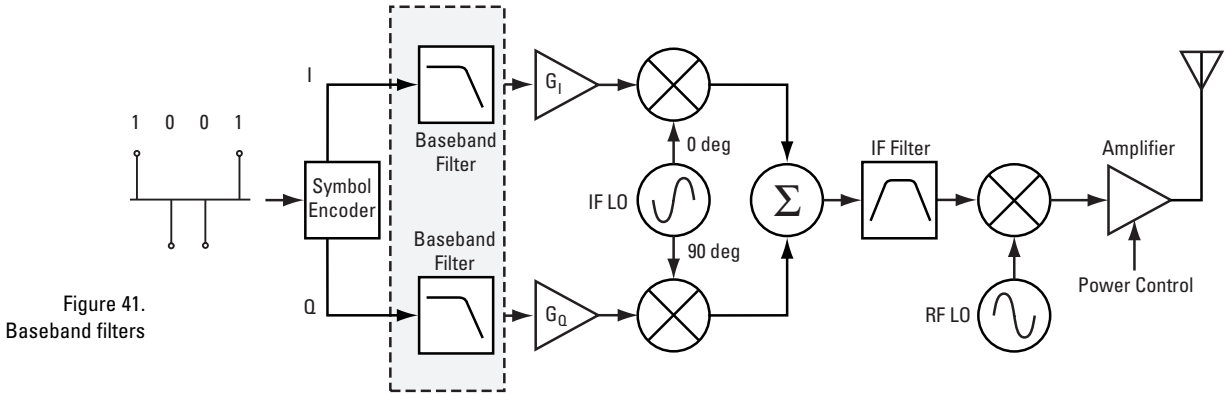

Figure 41. Baseband filters

Baseband filtering must be correctly implemented to provide the right baseband frequency response and avoid intersymbol interference and overshoot of the baseband signal. In systems using Nyquist filters, the roll-off parameter, alpha, defines the sharpness of the filter in the frequency domain. As shown in Figure 42, the lower the alpha, the sharper the filter in the frequency domain and the higher the overshoot in the time domain. It is important to verify that the transmitter has the appropriate baseband frequency response for the alpha specified.

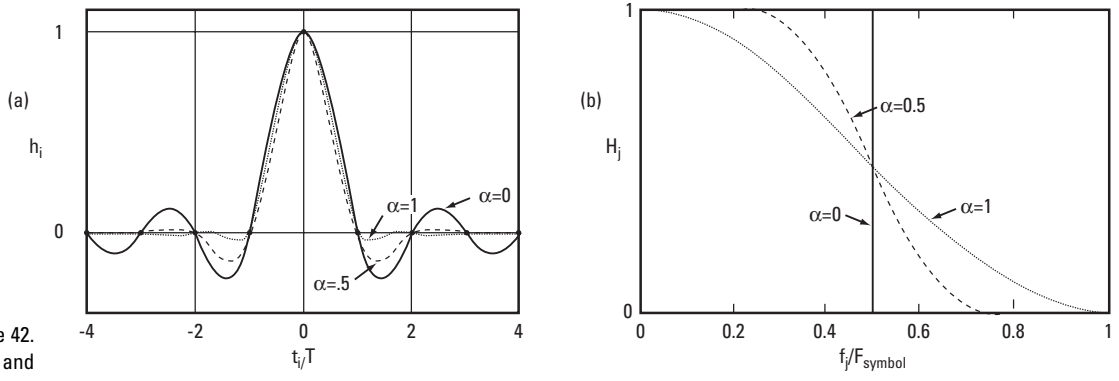

Figure 42. (a) Time and (b) frequency response of raised cosine filters with different alphas

In many communications systems using Nyquist baseband filtering, the filter response is shared between the transmitter and the receiver. The filters must be compatible and correctly implemented in each. The type of filter and the roll-off factor (alpha) are the key parameters that must be considered.

The main causes of error in baseband filtering are the following:

1. **Wrong filter coefficients.** For Nyquist filters, an error in the implementation of alpha may result in undesirable amplitude overshoot in the signal or interference in the adjacent frequency channel. It may also degrade intersymbol interference (ISI) caused by fading.

2. **Incorrect windowing of the transmitter filter.** Since the ideal frequency response of the Nyquist filter is finite, the ideal time response (impulse response) is infinite. However, the baseband filter is usually implemented as a digital FIR filter, which has a finite impulse response; that is, the actual time response is a truncated version of the ideal (infinite) response. The filter must be designed so that it does not truncate the ideal response too abruptly. Also, the filter must include enough of the ideal impulse response to prevent excessive distortion of the frequency response.

For example, Figure 43a shows the ideal time response and frequency response of a root-raised cosine filter for an alpha of 0.2. Figure 43b shows the actual time response after a flat time window has been applied. Since samples of significant value have been truncated, the actual time response is significantly different from the ideal, and the frequency response is distorted. The time window applied by the actual filter must be appropriate for the specified alpha to avoid too much distortion of the frequency response. In this case (Figure 43), the window applied is too short (in time), which increases ACP in the frequency domain.

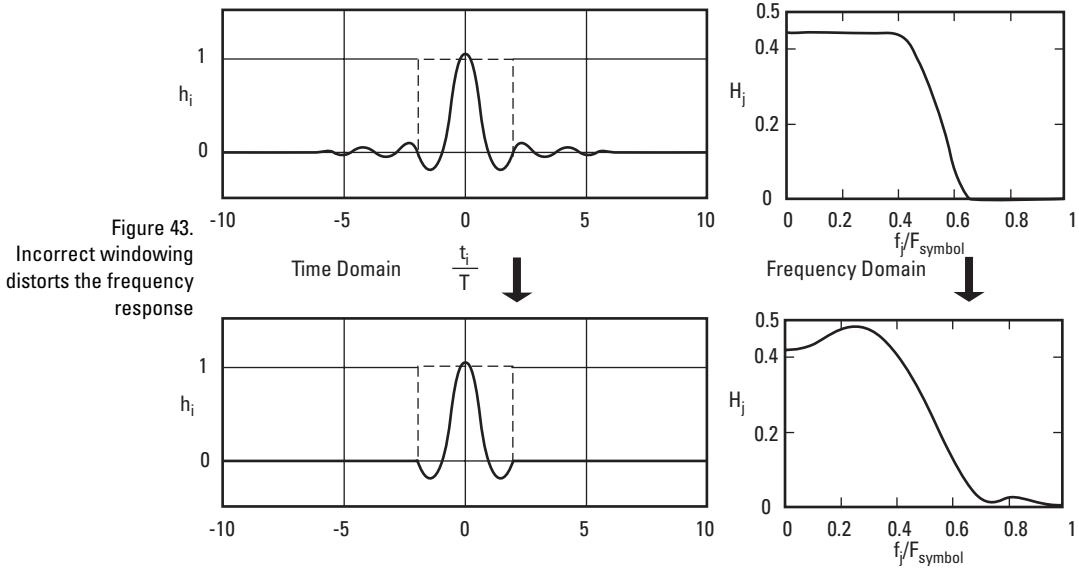
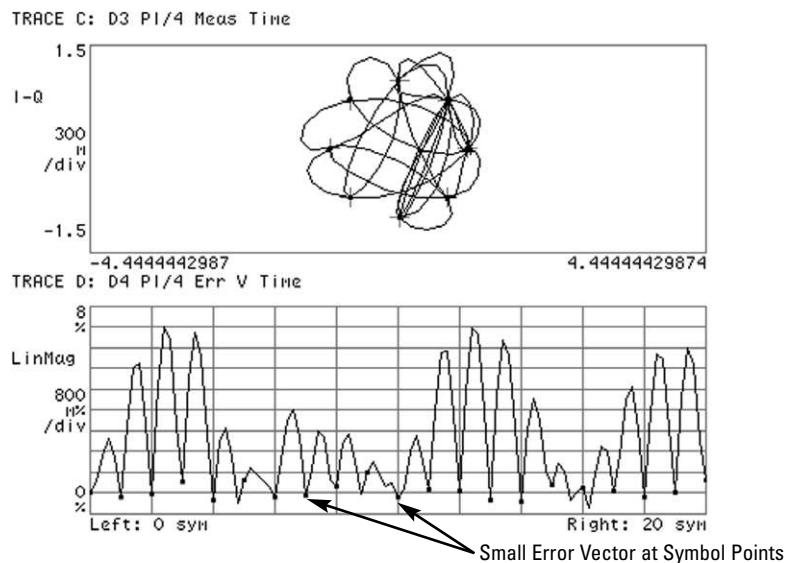

Figure 43. Incorrect windowing distorts the frequency response

How can you verify errors in the alpha coefficient and the windowing?

The main indicator of a wrong alpha coefficient and incorrect windowing is the display of **magnitude of the error vector versus time**. In systems that use Nyquist filtering, an incorrect alpha (or a mismatch in alpha between transmitter and receiver) causes incorrect transitions while the symbol points themselves remain mostly at the correct locations. Therefore, the EVM is large between the symbols, while it remains small at the symbol points. Figure 44 shows that effect for a mismatch between the transmitter filter (alpha = 0.25) and the receiver filter in the measuring instrument (alpha = 0.35, as specified for a particular system). Incorrect windowing has the same effect, since the actual baseband response of the transmitter and the baseband response applied in the measuring instrument no longer match. The amplitude overshoot of the baseband signal depending on the alpha can be observed in the polar diagram.

Figure 44.
(a) Polar diagram and
(b) magnitude of the error
vector versus time for
incorrect alpha. The error
vector is large between
symbol points and small at
the symbol points



Baseband filtering errors may also appear in the following measurements:

- **Channel bandwidth.** The 3dB bandwidth of a root-raised cosine filter is independent of the filter coefficient alpha. However, incorrect windowing may cause a dramatic change of the spectrum that may affect the 3dB bandwidth.
- **CCDF curves.** The roll-off factor, alpha, affects the amount of overshoot. Therefore, a filter with the wrong parameter may affect the statistics of the signal.
- **ACP.** Incorrect filtering may affect the degree of interference in the adjacent channel. The windowing applied in time also affects the ACP. The shorter the time window, for a particular alpha, the worse the ACP. More abrupt time windows also cause a larger ACP.
- **Code-domain power.** Distortion caused by mismatched filters can result in an increase in the code-domain noise floor.
- **Frequency response.** The frequency response of the baseband filter affects the total frequency response of the transmitter. Therefore, the effect of wrong filter coefficients or incorrect windowing can be analyzed by applying equalization and examining the transmitter's bits-to-RF frequency response, as seen in Figure 45a.

Equalization minimizes the errors caused by baseband filtering impairments. Figure 45b shows how equalization improves magnitude of the error vector versus time (compare to Figure 44b).

Figure 45.
 (a) Frequency response for incorrect alpha.
 (b) Magnitude of the error vector versus time improves with equalization

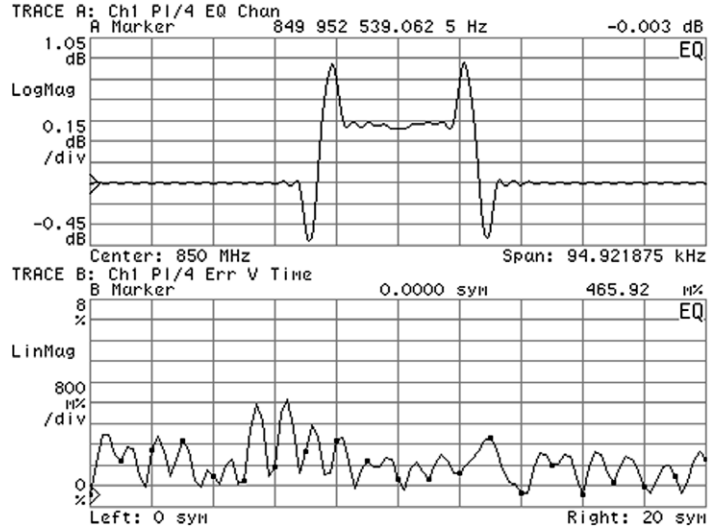

3.2.5 Incorrect interpolation

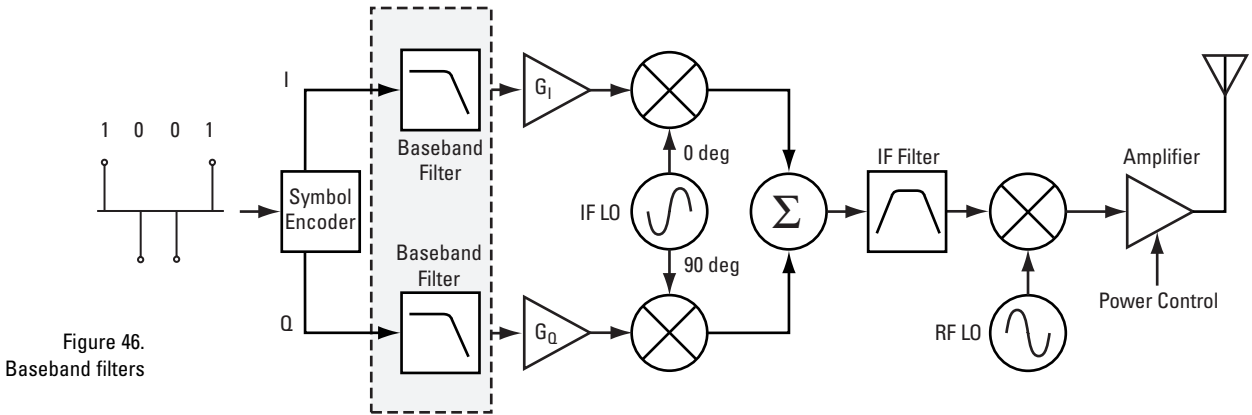
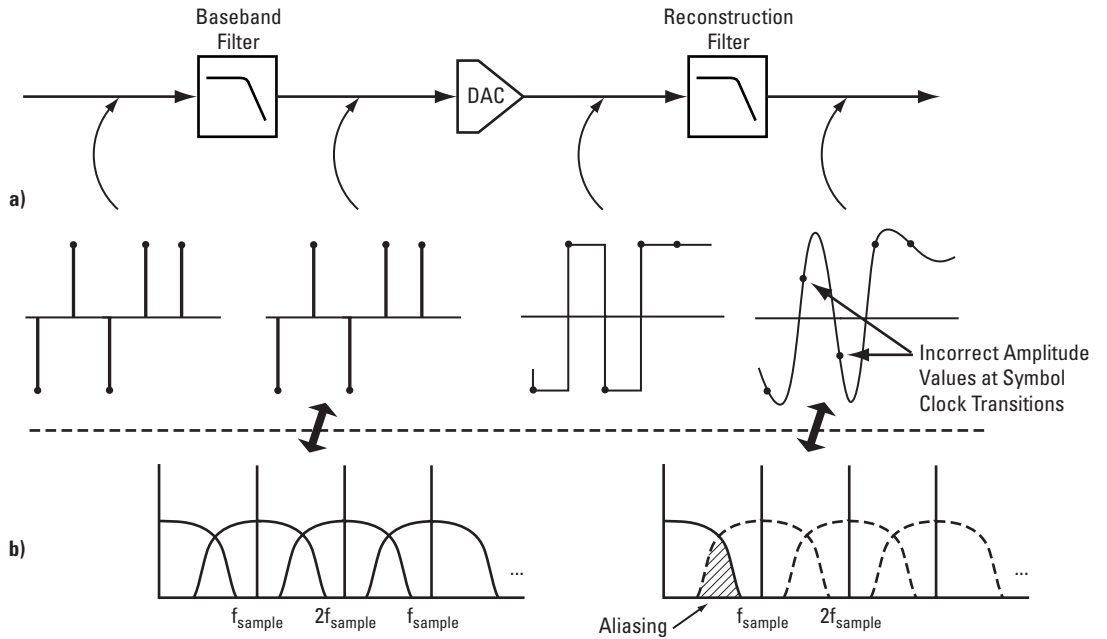

Figure 46.
 Baseband filters

As we saw earlier, baseband filters in the transmitters are usually implemented as digital filters. Digital techniques ensure that we can reproduce filters as many times as desired with exactly the same characteristics.

Since the RF signal is analog, the digital signal has to be converted to analog at some point in the transmitter. After the DAC used for that purpose, an analog reconstruction filter smooths the recovered analog signal by filtering out the unwanted frequency components. As per the Nyquist criteria, the sampling frequency should be at least twice the highest frequency component of the signal being sampled. In the case of a digitally-modulated signal, sampling at the symbol rate does not meet the Nyquist criterion. When recovering the analog signal, filtering could be an issue, and significant aliasing can occur, as shown in Figure 47.

Figure 47.
Sample rate = symbol rate.
Effect in
(a) the time domain and
(b) frequency domain



Therefore, it is recommended to use a sample rate at least twice as high as the symbol rate. This is accomplished by interpolating. The technique generally used consists of adding zeros between the samples before applying baseband filtering, as shown in Figure 48. Since the samples added are zeros, the time response of the filter is not affected. The only effect is to provide extra data points between the symbols. This better describes the transitions between waveforms. In the frequency domain, the images are now shifted much higher in frequency, thereby reducing the requirements of the reconstruction filter to a reasonable level.

Figure 48.
Interpolation:
sample rate =
4 x symbol rate.
Effect in the
(a) time domain and
(b) frequency domain

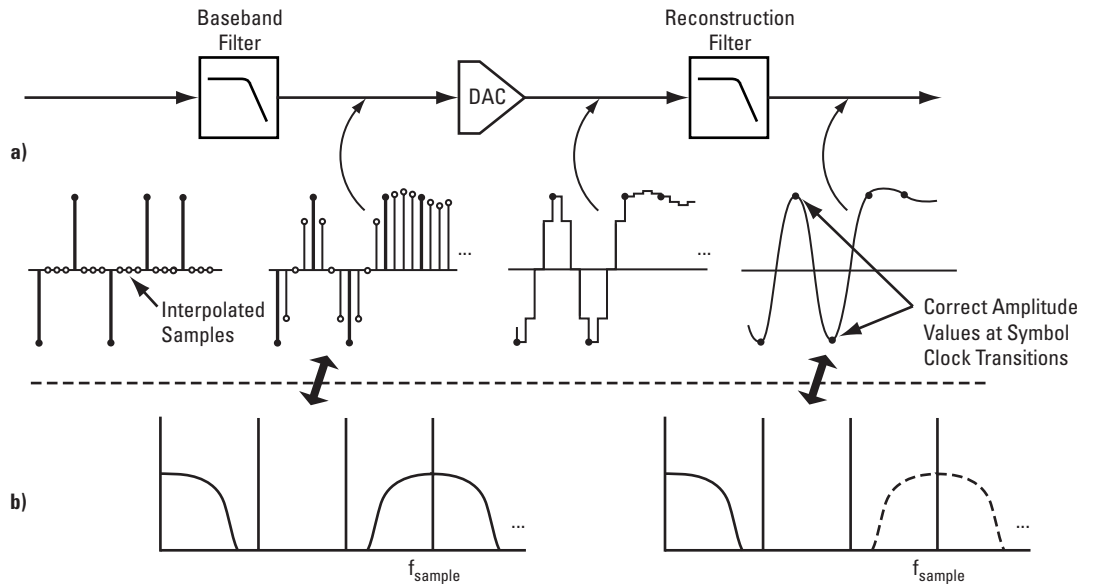

It is a common mistake to interpolate the I and Q signals as if they were pulses, instead of impulses. In other words, instead of adding zeros, it is a common mistake to add samples that have the same value as the original samples. The response of the filter is then affected, as shown in Figure 49. The frequency response of an impulse is a constant amplitude. When multiplied by the frequency response of the baseband filter, the correct spectrum is obtained. The frequency response of a pulse in the time domain is a $\sin(x)/x$ function, where $x = \pi f t$ and t is the width of the pulse. When the pulse signal is filtered, its frequency response gets multiplied with the filter's response. The result, for a transmitter with analog I/Q modulation, is an incorrect spectrum that has a rounded top instead of a flat one. In the case of a transmitter with digital IF, this error could cause different effects.

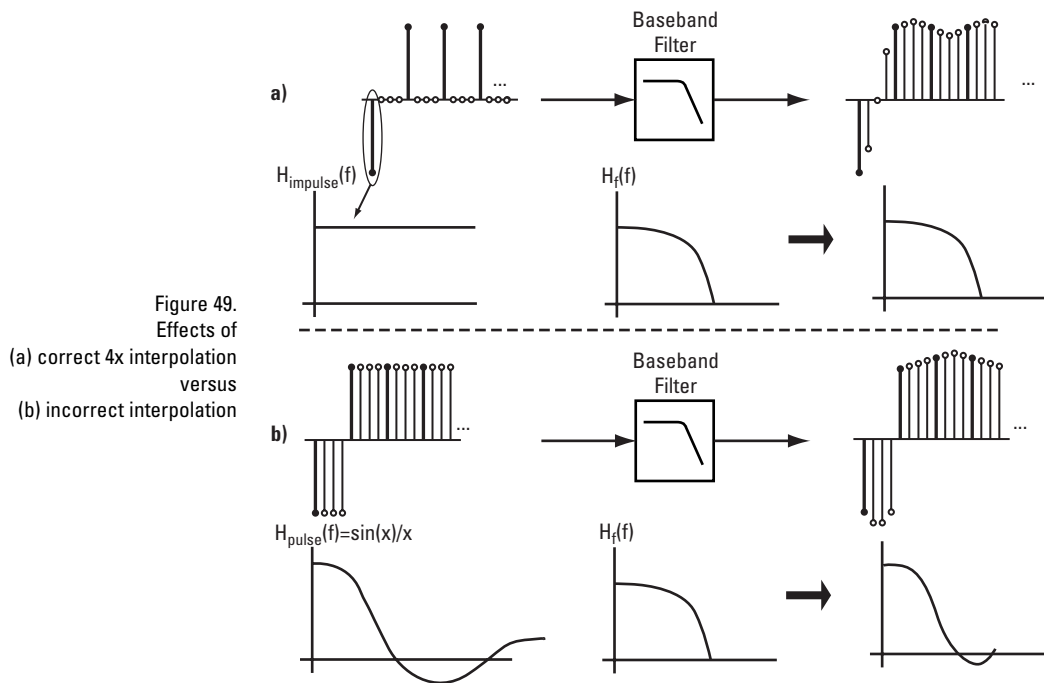

Figure 49.
Effects of
(a) correct 4x interpolation
versus
(b) incorrect interpolation

If different sections of the transmitter are designed with different sampling rates, an interpolation problem may also occur. For instance, if the FIR filter (or the digital IF section) and the DAC work at different rates, some kind of interpolation between these sections is required. In this case, either adding zeros or samples equal to the original ones to the signal between the two sections may distort the signal.

How can you verify interpolation errors?

Since incorrect interpolation modifies the overall baseband filter frequency response, intersymbol interference occurs. Therefore, the **polar** or **constellation diagram** and **EVM** are degraded. The best way to verify interpolation errors is by applying equalization to remove the effects of those errors in the polar or constellation diagram and EVM (see Figure 50), and checking the **bits-to-RF frequency response**. Assuming there are no other linear errors, the frequency response should look similar to the $\sin(x)/x$ function that the equalizer is compensating for, as shown in Figure 51.

Incorrect interpolation can also affect the following measurements:

Figure 50. Effect of equalization on signal with incorrect interpolation: polar diagram and magnitude of the error vector versus time (a) without equalization and (b) with equalization

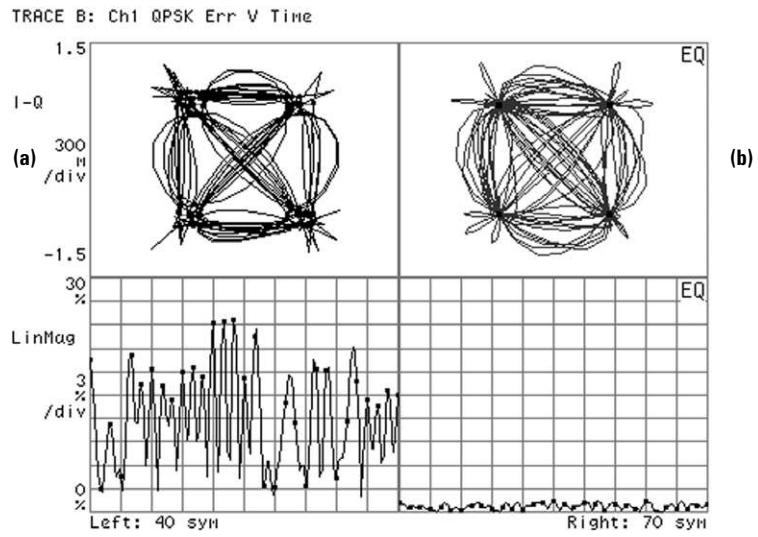
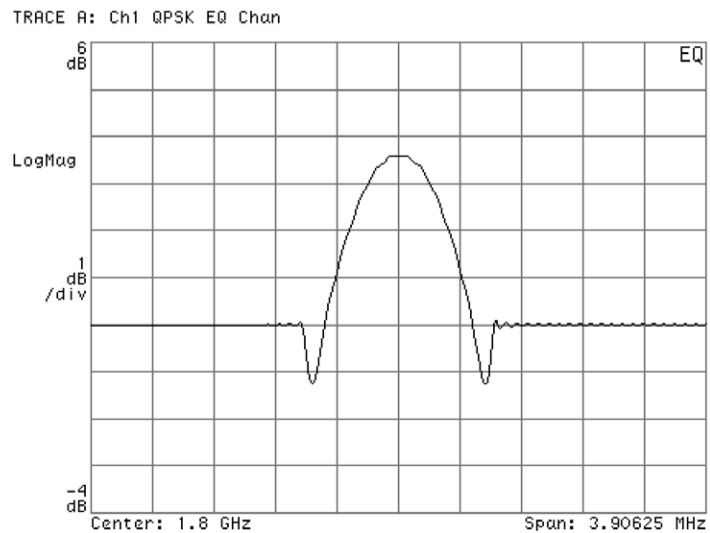
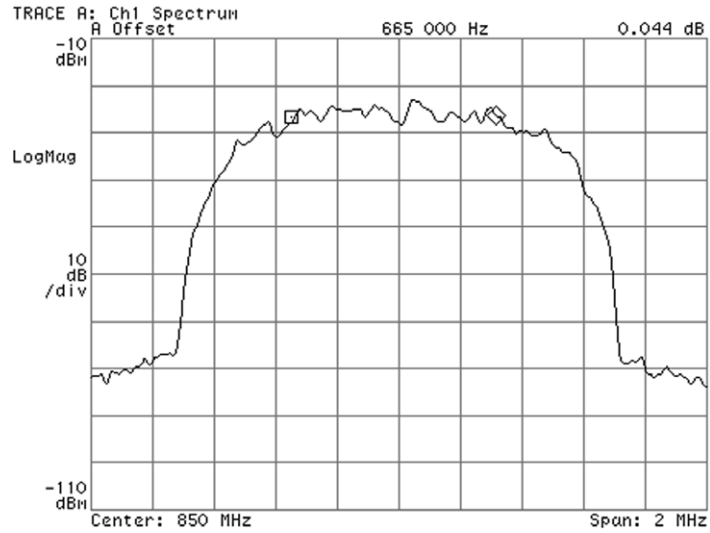

Figure 51. Bits-to-RF frequency response of transmitter with incorrect interpolation



- **Channel bandwidth.** Incorrect interpolation has an impact on the spectrum shape. For instance, for a transmitter with analog I/Q, the spectrum of a signal with incorrect interpolation has a rounded top instead of a flat one. Therefore, the channel bandwidth measurement may be affected. For example, Figure 52 shows a 3 dB bandwidth of 665 kHz for a signal with a symbol rate of 1 MHz.

Figure 52.
Spectrum of signal with
incorrect interpolation



- **CCDF curves.** Incorrect interpolation may distort the signal and, therefore, its statistics may change.
- **ACP.** Incorrect interpolation may cause an increase in the ACP.
- **Code-domain power.** Since EVM is degraded, the code-domain power noise floor may increase.

3.2.6 IF filter tilt or ripple

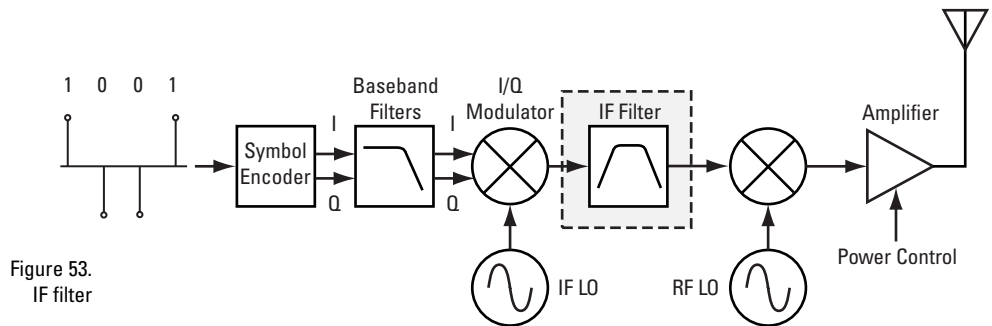
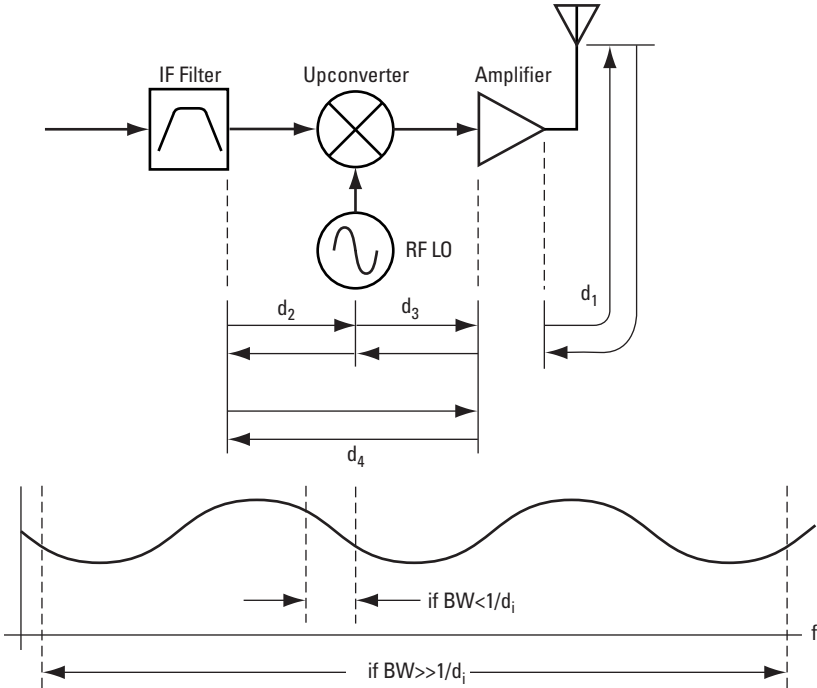

Figure 53.
IF filter

The IF filter eliminates out-of-channel interference created during the I/Q modulation. Error characteristics in the design of this filter can affect the resulting signal. Ideally, the filter should be flat across the frequency band of interest and its group delay should be constant across the same frequency band. Common IF filter impairments include filter tilt or ripple in the frequency response and variations of group delay. For instance, SAW (Surface Acoustic Wave) filters may have internal reflections that cause long delays, which produce fine-grain ripple in the frequency response. Filter tilt or ripple in the frequency response causes linear distortion in the signal.

An effect equivalent to filter tilt or ripple is often caused by improper matching of any component from the IF filter to the antenna. For example, mismatch between the RF amplifier and the antenna or between any components in the IF or RF section of the transmitter may cause reflections that result in distortion of the overall transmitter's frequency response. The distortion is either tilt or ripple, depending on the distance between the mismatched components and the bandwidth of the signal. As you can see in Figure 54, for narrow bandwidths relative to the inverse of the distance between the components, the frequency shape appears tilted. For wide bandwidths it appears rippled. The effect of mismatch between components is usually negligible for the bandwidths used in wireless RF applications ($BW \ll 1/d_i$), while it becomes more important in applications using wider bandwidths, such as LMDS (Local Multipoint Distribution System) or satellite applications.

Figure 54. Mismatch between IF or RF components may cause tilt or ripple in the frequency response



How can you verify filter tilt or ripple?

Filter tilt or ripple causes distortion of the demodulated baseband signal. Therefore, the **constellation** and **EVM** are degraded. The best way to verify IF filter errors or equivalent effects is by applying equalization to the signal and checking the **bits-to-RF frequency response**. Equalization removes linear distortion. Therefore, both the constellation and magnitude of the error vector versus time should improve noticeably. Assuming that there are no other linear errors in the transmitter, the bits-to-RF frequency response shows the ripple or the tilt, as seen in Figure 55

Figure 55.
Bits-to-RF frequency
response of a
transmitter with
IF filter tilt

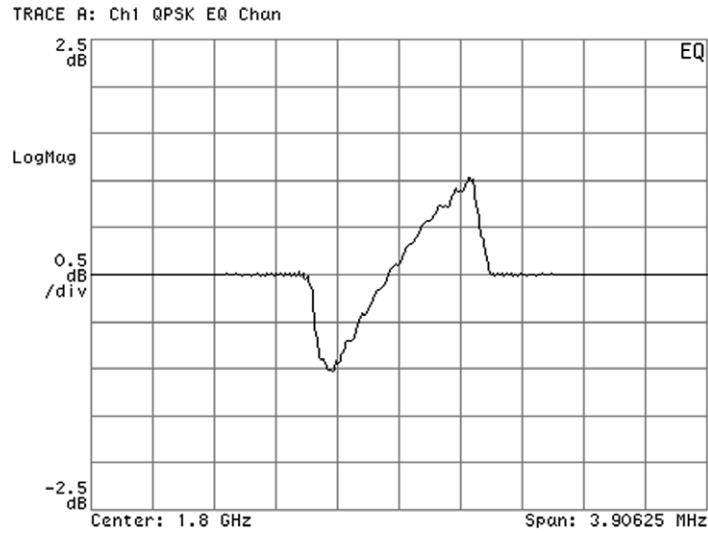

In the case of SAW filters, the time delays in the filter impulse response can be further analyzed by increasing the equalizer filter length and observing the equalizer impulse response.

Filter tilt or ripple may also appear in the following measurements:

- **Channel bandwidth.** Tilt and ripple may show subtly in the frequency domain if averaging is applied.
- **CCDF curves.** Tilt or ripple affect the statistics of the signal, and therefore the CCDF curves.
- **Code-domain power.** Filter tilt or ripple can also raise the code-domain power noise floor.

Figure 56.
IF and RF LOs

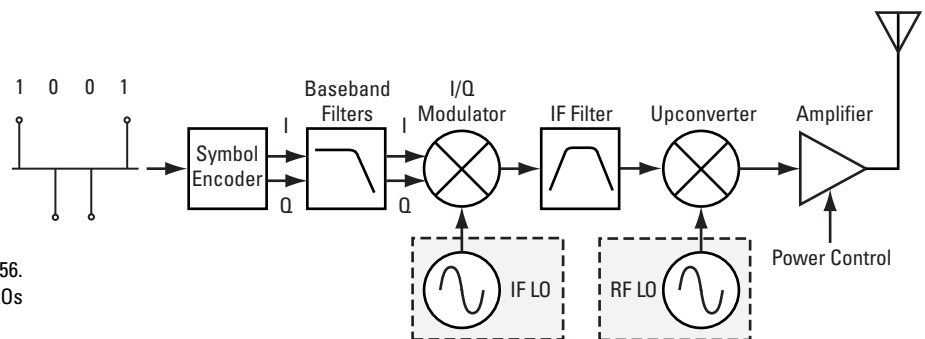

3.2.7 LO instability

The RF LO characteristics are passed on to the final RF signal. If the frequency is unstable, the channel occupation restrictions may be violated and interference with adjacent channels may occur. LO instability may be caused by hum or other signals that run close to the LO. For instance, data lines (typically CMOS1) carry signals with steep edges that can couple RF energy to an LO. Phase noise in any LO in the transmitter can also cause noise in the phase of the recovered I/Q signal. Phase noise at far offsets in the RF LO may be fed through and cause energy to be spilled into the adjacent channel.

¹See Glossary.

How can you verify LO instability?

A large phase error relative to the magnitude error gives the best indication of instability in an LO. The error can be further analyzed by examining the **phase error versus time** display. This display shows the modulating waveform of any residual or interfering PM signal. Random phase errors indicate phase noise, while sinewave shapes or periodic waveforms indicate interfering PM tones. For example, Figure 57 shows the phase error versus time for a signal with a symbol rate of 50 kHz. Since the phase error versus time shows two cycles over 2000 symbols, the frequency of the interfering PM signal is $2 \times (50 \times 10^3) / 2000 = 50$ Hz.

Figure 57.
Phase error versus time
for a signal with hum

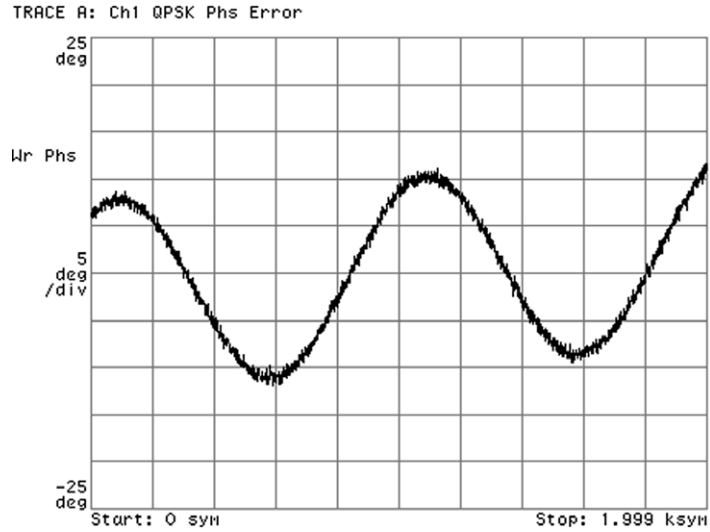

If the LOs in the transmitter are accessible, the problem can be tracked down to a specific LO by making analog PM measurements on the different LOs of the transmitter.

Bad cases of LO interference cause a **constellation** display like that shown in Figure 58. The measured symbols preserve the right amplitude but vary in phase around the ideal symbol reference point.

Figure 58.
Constellation display
degraded by phase noise

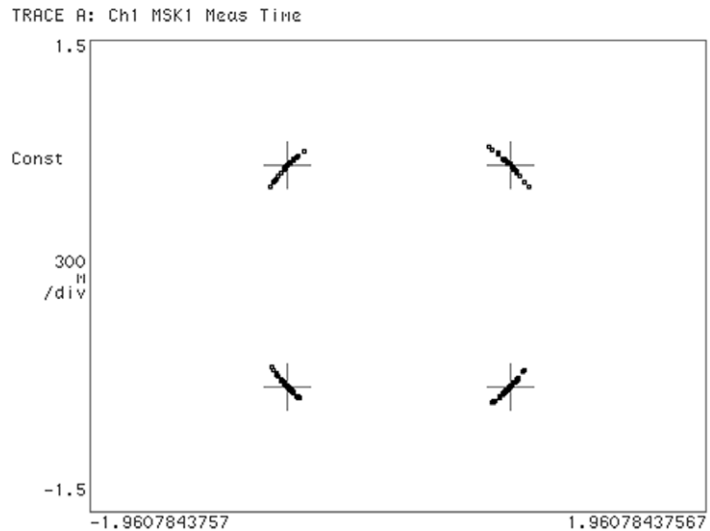

LO instability also impacts the following measurements:

- **Adjacent Channel Power.** As indicated earlier, residual PM or phase noise at far offsets in the RF LO can degrade the ACP (see Figure 59).

Figure 59.
ACP degraded by phase noise at far offsets

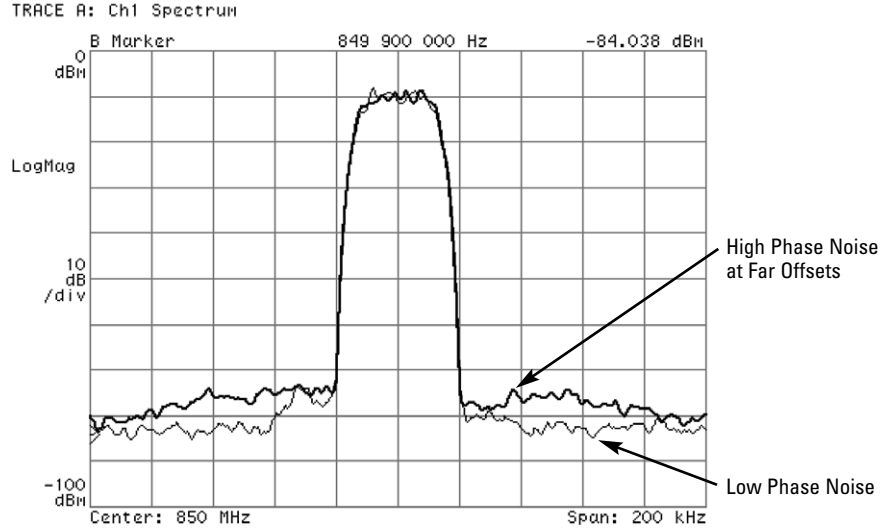

- **Code-domain power.** LO instability appears in the code-domain power display as an increase in the noise level in certain non-active code channels. The code channels affected depend on the orthogonal coding scheme of the particular system and on the code-channel configuration of the signal. Figure 60 shows the code-domain power display for a signal with phase noise.

Figure 60.
Code-domain power for signal
(a) without phase noise and
(b) with phase noise

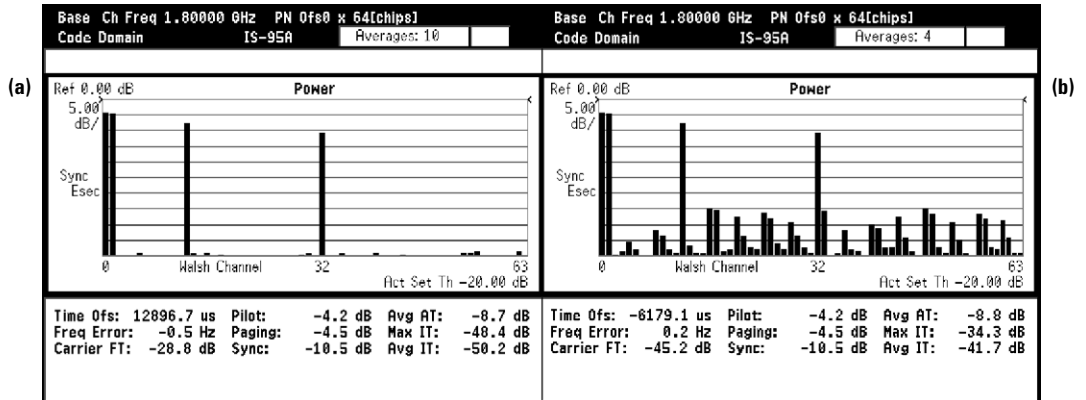

LO instability is not a linear error and cannot be removed by equalization.

3.2.8 Interfering tone

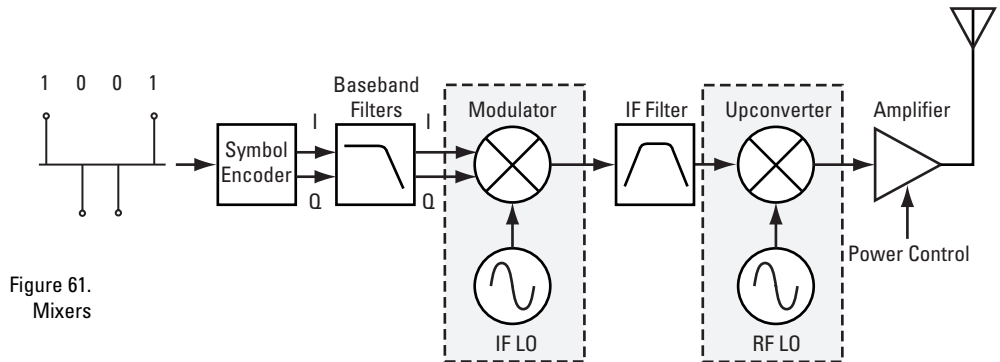

Figure 61.
Mixers

A tone or spur generated anywhere in the transmitter can interfere with the transmitted signal if it falls in the signal's bandwidth. In-channel interfering tones are usually masked by the signal in the frequency domain.

If the interfering tone is outside of the signal's bandwidth, it can cause interference with other channels or systems.

Interfering tones are typically caused by interactions of internal signals in active devices (such as mixers and amplifiers).

How can you verify the presence of interfering tones?

Out-of-channel or **out-of-band spurious** are easily detected by spurious/harmonics measurements if the test instrument has sufficient dynamic range (see Figure 62).

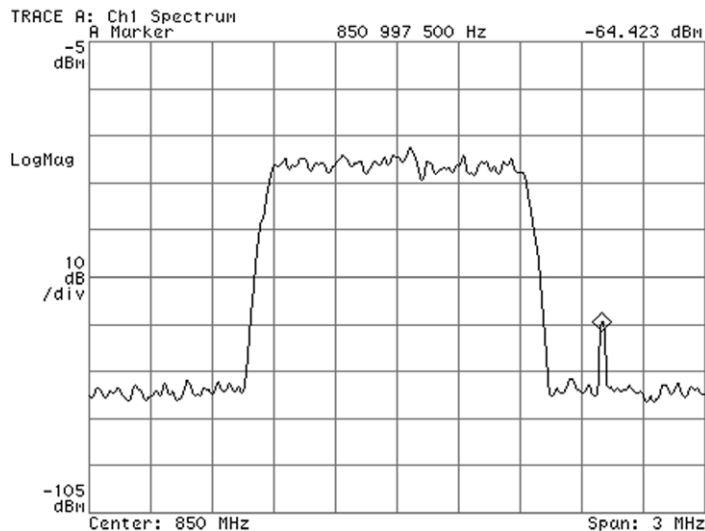
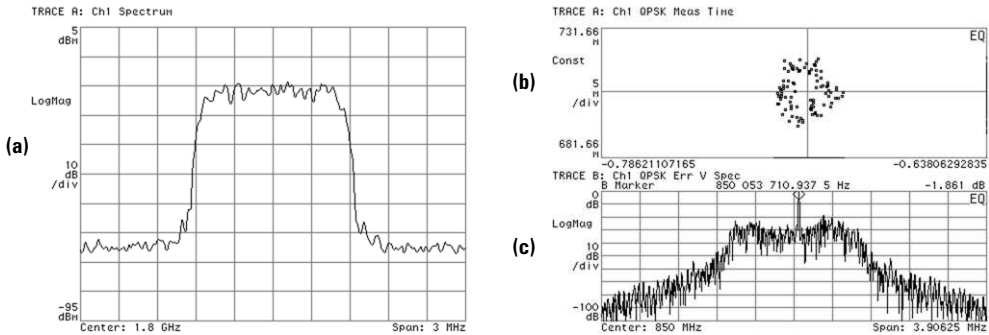

Figure 62.
Out-of-channel spur
(spectrum view)

In-channel spurious cause interference in the modulation. A single spur combines with the modulated signal, and the result depends on their phase relationship. The spur is rarely high enough to be detected in the frequency domain, but it may be identified in the **constellation** because it forms circles around the reference points. The radius of the circle corresponds to the magnitude relationship between the interfering tone and the desired I/Q signal. There may be some randomness caused by noise and, if the spur is very small, the circle might not be clear, even when zooming onto a single constellation point, as in Figure 63b. The best way to determine if an in-channel spur is present is by looking at the **error vector spectrum**. The magnitude and frequency offset of the spur from the unmodulated carrier can be measured from this display. For instance, the error vector spectrum in Figure 63c shows a spur at 850.053710 MHz (53.710 kHz away from the unmodulated carrier frequency).

Figure 63. In-channel interfering tone not visible in (a) the frequency domain, but detectable in (b) the constellation and (c) error vector spectrum



An interfering tone within the frequency bandwidth of the modulated signal also results in uncorrelated energy that raises the **code-domain power** noise floor.

Interfering tones are not linear impairments and cannot be removed by applying equalization, although the signal quality may improve somewhat, since the equalizer helps minimize EVM.

3.2.9 AM-PM conversion

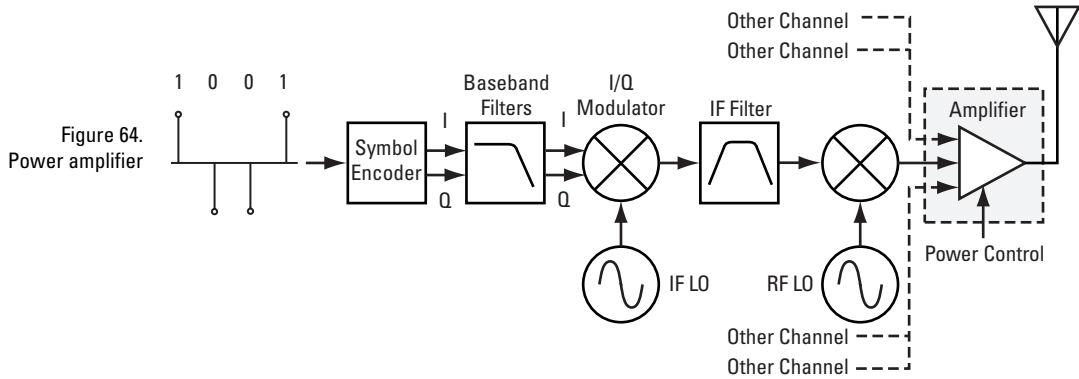

As mentioned earlier, the frequency and amplitude responses are important characteristics of power amplifiers. Apart from compression (AM-AM conversion), power amplifiers may cause phase distortion for high levels of signal amplitude. This effect is known as AM-PM conversion, illustrated in Figure 65.

Figure 65.
AM-PM conversion

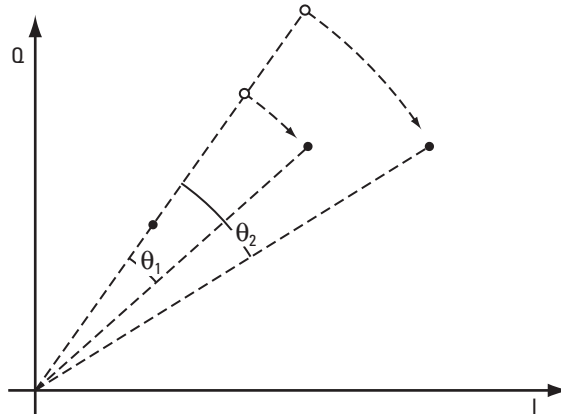

AM-PM conversion typically occurs at the linear range of the amplifier; that is, for amplitude levels below compression. It is particularly relevant for signals with high peak-to-average power ratios, where different amplitude levels suffer different phase shifts.

How can you verify AM-PM conversion?

The best way to verify AM-PM is by isolating the amplifier and measuring its AM-PM characteristics (using a network analyzer, or a signal analyzer with PM demodulation capability).

If the amplifier cannot be isolated, the best way to verify AM-PM conversion is by looking at the **polar diagram**. Comparing the actual trajectory of the signal with its ideal trajectory for a few symbols shows higher errors for higher amplitude levels, as seen in Figure 66. Because small errors at lower amplitudes may cause relatively large phase errors, the correlation between higher amplitudes and large phase errors may not be obvious. Filtering at the receiver causes dispersion in time. Therefore, AM-PM conversion may cause an error in the symbol(s) after a peak excursion of the signal.

Figure 66.
Polar trajectory of a signal
with AM-PM conversion
(relative to ideal trajectory)

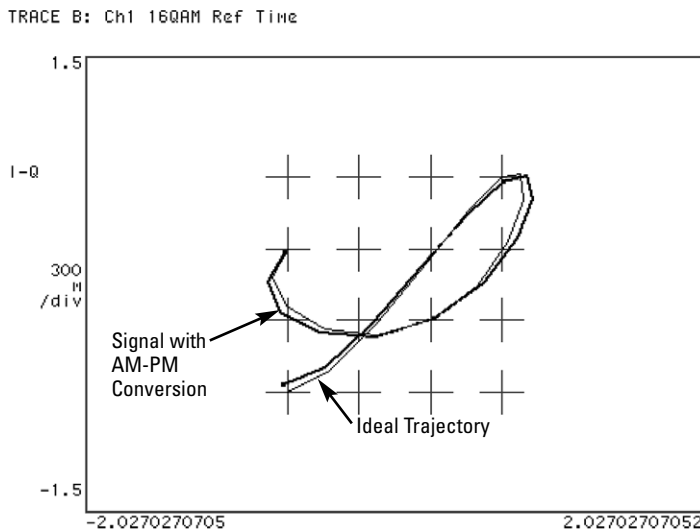

The **code-domain power** measurement may also be affected by AM-PM conversion. Since the error is highly correlated with the signal, the code-domain energy may appear in the non-active channels in deterministic ways.

AM-PM conversion is not a linear error and cannot be removed by equalization.

3.2.10 DSP and DAC impairments

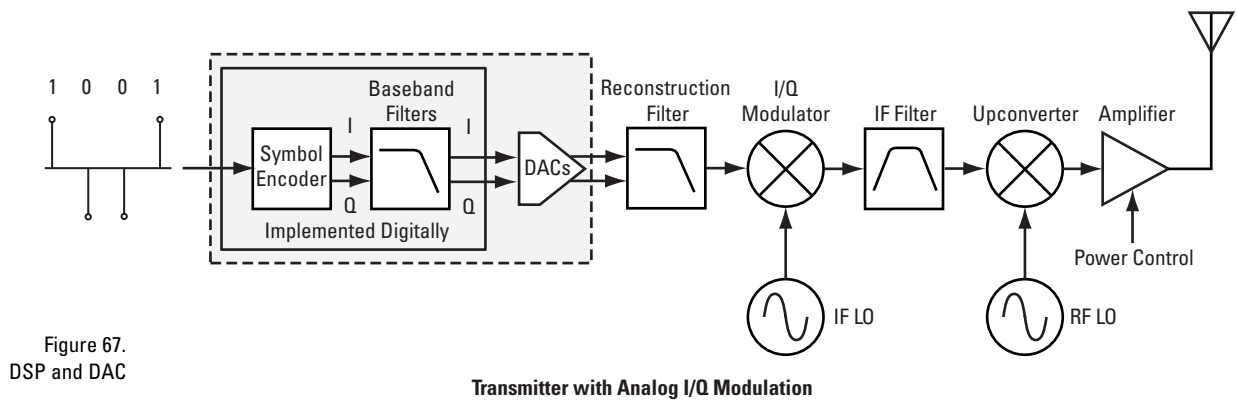
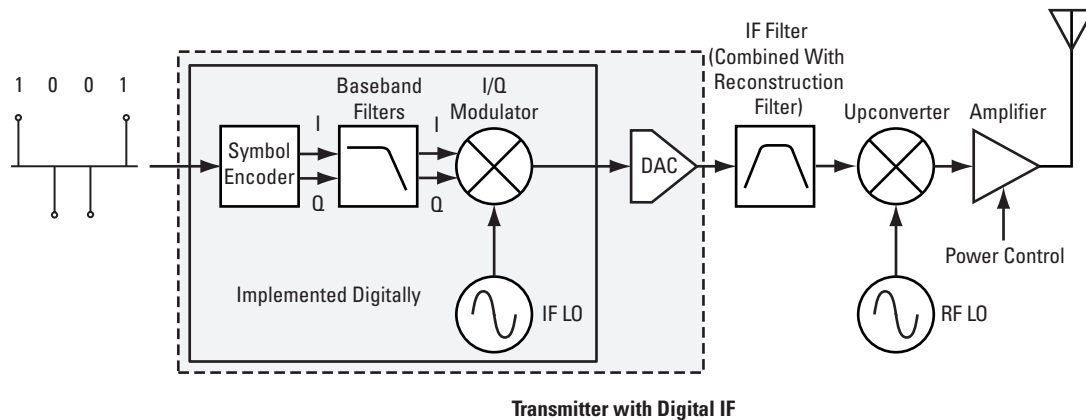
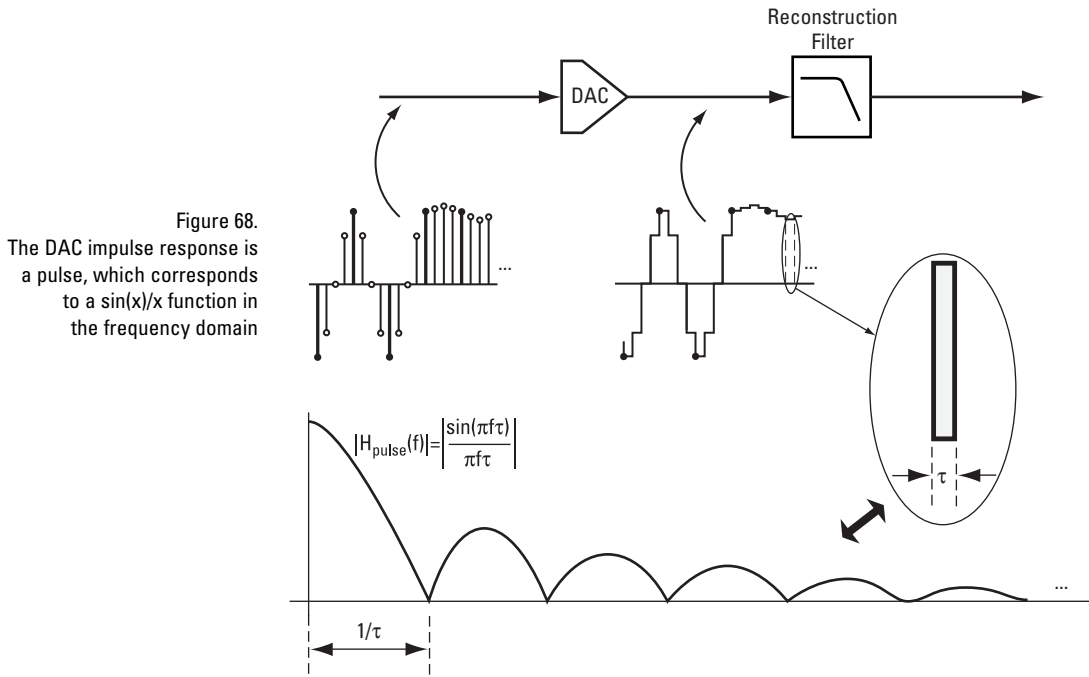

Figure 67.
DSP and DAC



Although it is possible to implement digital modulation using all analog hardware, it is becoming more and more common to digitize the input signal immediately and stay with digital processing right through to the IF. The IF is then converted to analog prior to upconverting to the final frequency for transmission. The DACs can be placed at various points depending on the actual implementation, as shown in Figure 67. Digital processing and conversion may be subject to problems. The most common impairments are **non-compensated $\sin(x)/x$ and internal overflow**.

Non-compensated $\sin(x)/x$. Although the ideal output of the DAC is a series of delta impulses that represent the different amplitude levels, in practice the 'impulses' have a certain width (τ) prior to the reconstruction filter that smooths the signal. A pulse in the time domain translates into a $\sin(x)/x$ function in the frequency domain, as shown in Figure 68. There must be compensation for the $\sin(x)/x$ shape somewhere in the transmitter design.



The compensation can be implemented digitally somewhere before the DAC, or in combination with the analog reconstruction filter (see Figure 69) or the IF filter (Figure 70).

It is a common error not to compensate for this $\sin(x)/x$ shape. Figure 69 illustrates the importance of the compensation for a transmitter with analog I/Q modulation. Non-compensation causes distortion in the spectrum of the transmitted signal. If the symbol period (T) is comparable to the pulse width (t), not compensating for the $\sin(x)/x$ function can cause an effect as dramatic as incorrect interpolation.

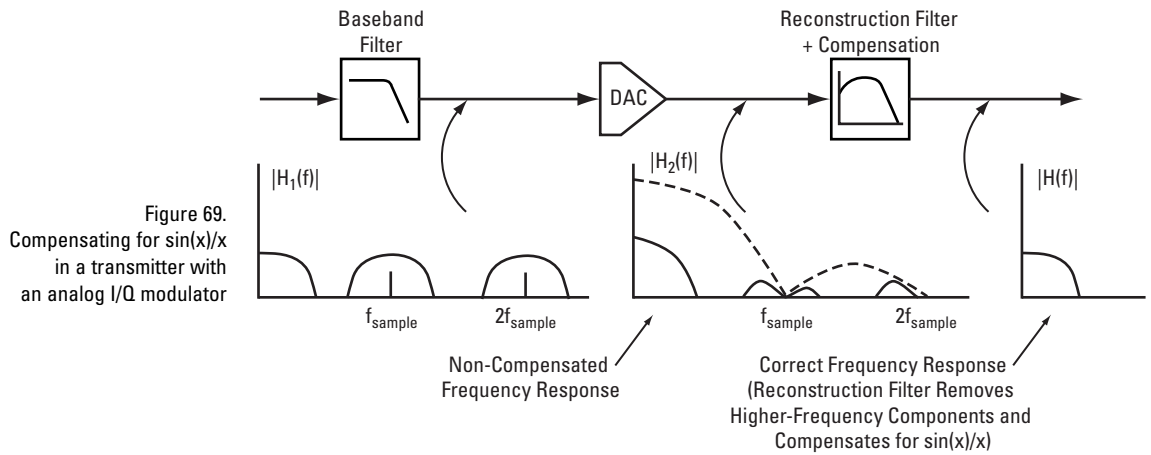
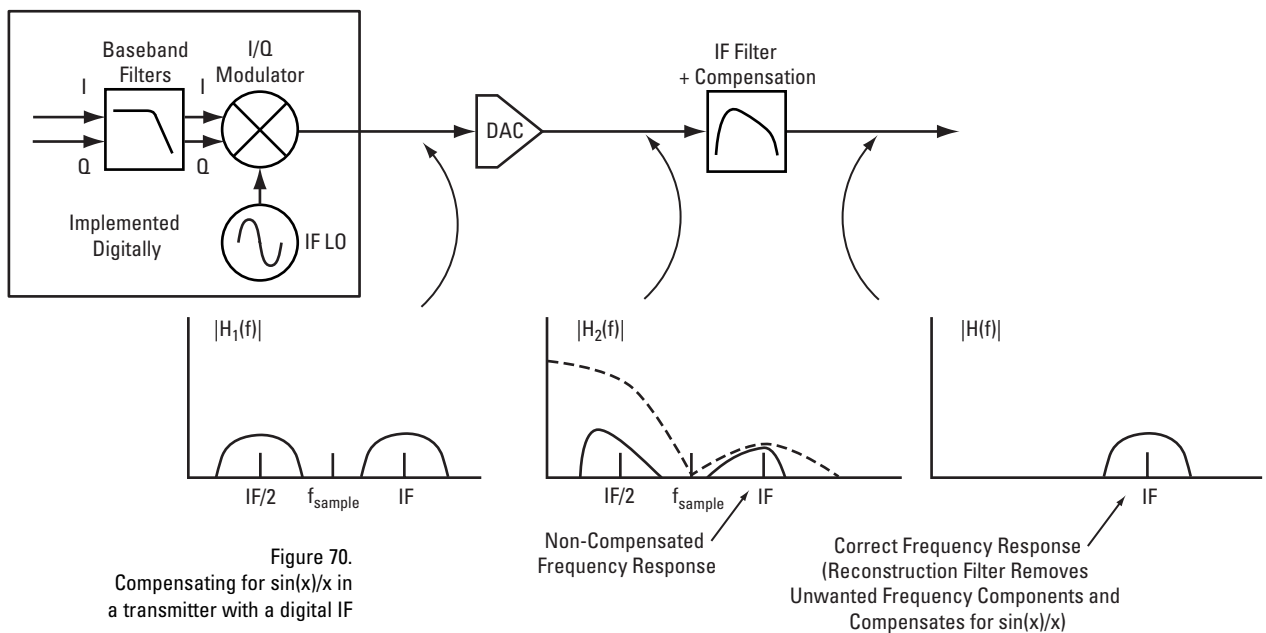

Figure 70 illustrates the effect of compensation for a transmitter with a digital IF. If there were no compensation, the spectrum of the transmitted signal would be tilted.



How can you verify non-compensated $\sin(x)/x$?

As with incorrect interpolation, not compensating for the $\sin(x)/x$ function degrades the modulation quality. Since it is a linear error, it can be removed by equalization. Therefore, this kind of error can be easily detected by applying equalization and examining the transmitter's **bits-to-RF frequency response**. In the case of a transmitter with an analog I/Q modulator, the frequency response shows a $\sin(x)/x$ shape, similar to the frequency response for incorrect interpolation (Figure 51). In the case of a transmitter with a digital IF, the frequency response shows a tilt, similar to the frequency response for IF filter tilt (Figure 55).

With equalization, the **constellation** and **EVM** improve as for incorrect interpolation (see Figure 50).

As in the case of incorrect interpolation, non-compensated $\sin(x)/x$ may also cause an impact on **channel bandwidth, CCDF curves, ACP and code-domain power**.

Internal overflow. There are several scaling errors associated with digital hardware. For instance, in a DSP, when a mathematical function produces an output that is greater than the largest possible value, the result is incorrect. For example, if we add 0101 to 1101, the result should be 10010, but in a 4-bit processor the MSB (Most Significant Bit) would be lost and the result would be 0010. To avoid this error, DSPs can operate in a special mode called saturation. In that case the DSP saturates to all ones if the result is greater than the largest possible value, and to all zeros if the result is less than the smallest acceptable value.

How can you verify errors caused by internal overflow?

If the DSP's algorithms yield values greater than its design allows, artifacts can occur in the modulation. For example, as we saw above, the DSP can roll over signal values that are higher than its design allows to voltage levels that are very low. This error is usually confined to a single output, which causes spikes in the **magnitude of the error vector versus time** display, as shown in Figure 71b.

Figure 71.
Effects of internal overflow on
(a) the constellation and
(b) the magnitude of the error vector versus time display

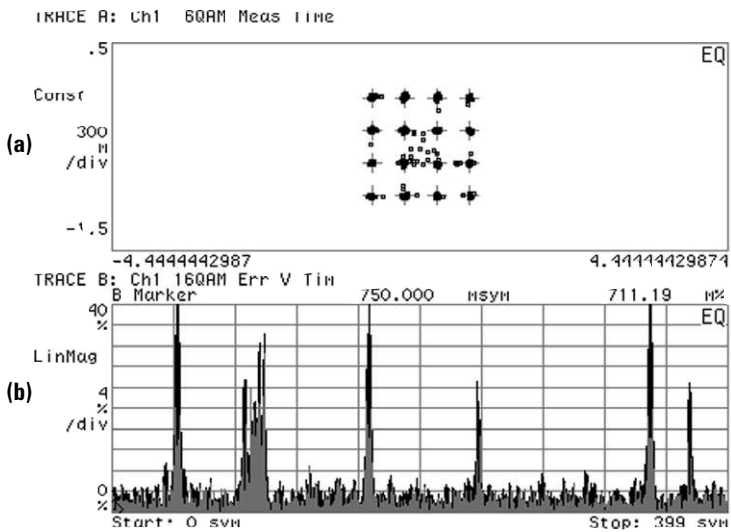

Internal overflow may also affect the following measurements:

- **ACP.** Internal overflow may cause glitches in the signal, which cause spectral splatter and therefore an increase in ACP. Time capture and a spectrogram function are useful tools for analyzing transients and spectrum splatter.
- **Code-domain power.** Since EVM is affected, internal overflow errors may also increase the code-domain power noise floor.

Equalization does not remove errors caused by internal overflow, since these are not linear.

3.2.11 Burst-shaping impairments

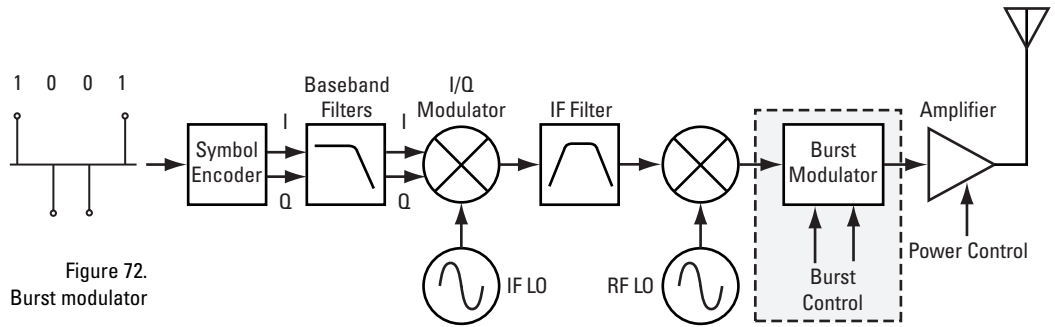

Figure 72.
Burst modulator

In TDMA systems, the RF power is bursted on and off in well-defined time slots such that the frequency channel can be shared with other users. It must be ensured that the burst parameters are accurate. These parameters include the **rise and fall times** as well as the **burst width**. The power must be on long enough to transmit the timeslot data. During the off time the power must be low enough to be considered off. Other potential problems include **overshoot on power-up, frequency drift** and **amplitude droop**.

In TDMA systems, the transmitter output is turned on and off many times per second. Instability in frequency and power as the burst is turned on can seriously impair the operation of the system. Overshoot on power-up can also result in compression at the amplifier, which raises the interference in the adjacent frequency channels. Frequency drift also causes higher interference levels in the adjacent frequency channels.

Temperature changes in the components of the burst modulator (Figure 72) may cause changes in the amplitude of the signal when the burst is on. This artifact is known as amplitude droop and affects the modulation quality of the signal.

Rise and fall times that are too long affect adjacent timeslots. The rise and fall times of the waveform are directly related to the spectrum splatter during the turn-on and turn-off of the burst. This splatter affects the ACP. The faster the rise and fall edges of the burst, the more spectrum required, and therefore the higher the interference in the adjacent frequency channel.

TDMA and frequency-agile systems have much in common. When the carrier hops from frequency to frequency, the transmitter is still turning on and off many times per second. The same burst issues apply. Adjacent channel interference is still a concern. It is therefore important to characterize the burst shape parameters and associate them with the measurement results to isolate the cause of the problem.

How can you verify burst-shaping impairments?

The best way to detect most burst-shaping errors is by performing the appropriate **timing measurements**. Figure 73 shows an example in which the rise and fall times are too long.

Figure 73.
Burst rise and fall times too long

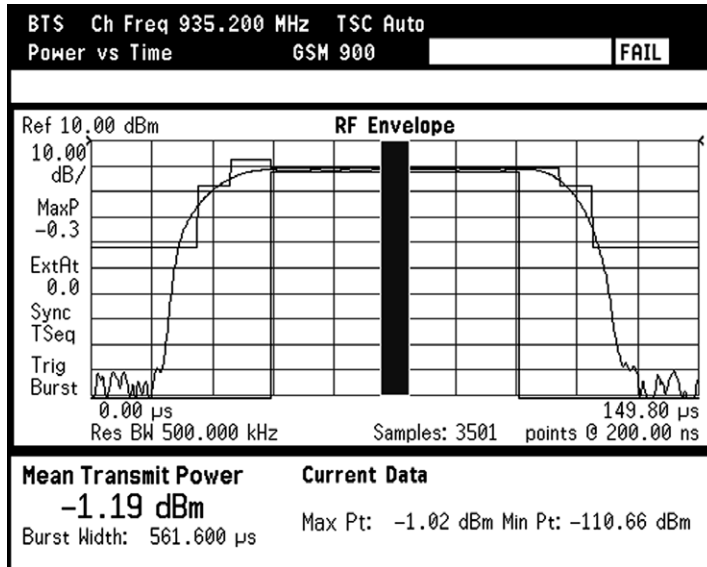

The best way to troubleshoot burst-shaping impairments that affect **ACP**, such as short rise and fall times and frequency drift, is by combining the time and the frequency domain. Time capture and a spectrogram function that shows how the apparent frequency spectrum varies with time are the ideal tools for that. The spectrogram can be used to view a three-dimensional picture of what is happening. Frequency drifts and high adjacent channel interference due to sharp edges can be easily detected, as seen in Figure 74.

Figure 74.
Spectrogram showing high ACP
caused by short rise time

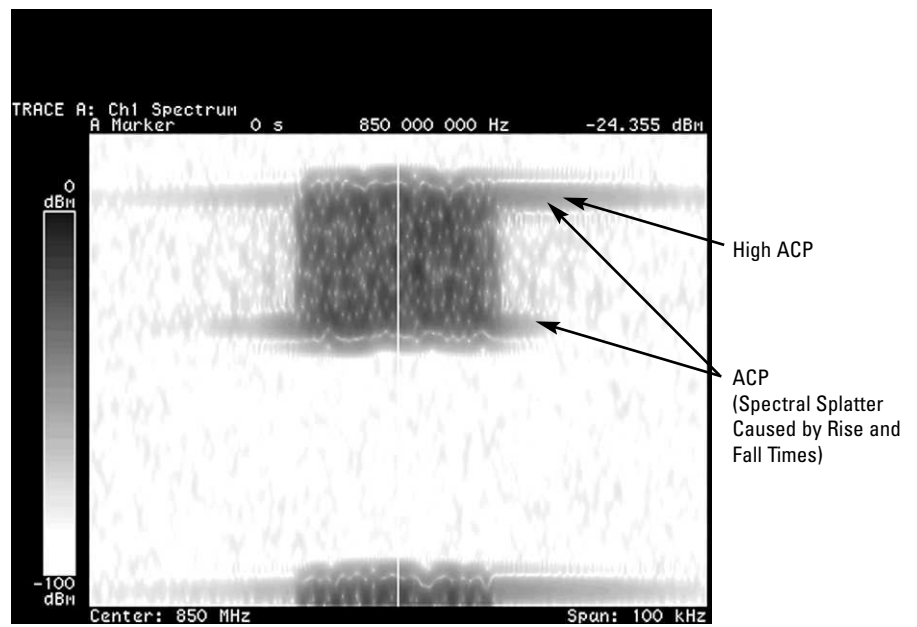

The modulation quality of the signal may be affected by most burst-shaping errors, such as amplitude droop, overshoot on power-up, frequency drift and too short a burst width. Those errors have an impact on EVM and the related displays. Amplitude droop, for instance, may be easily detected by looking at the **magnitude error versus time** display, as shown in Figure 75. The measurement algorithm may compensate for amplitude droop. In that case the error is given in a separate metric.

Figure 75.
Magnitude error versus
time for a signal with
amplitude droop

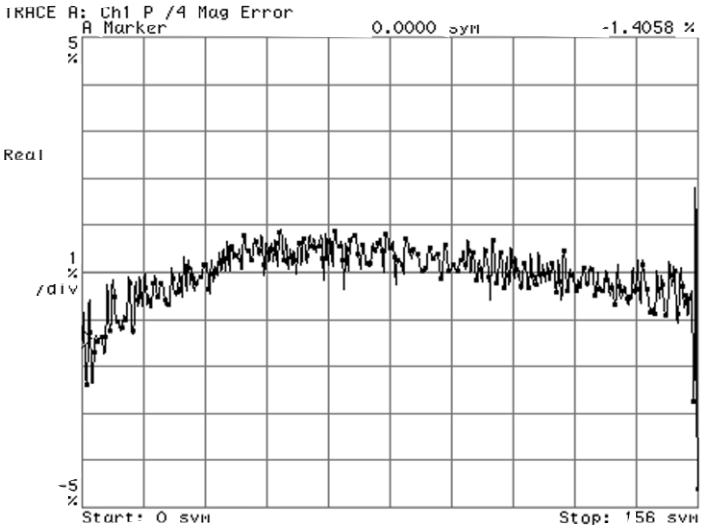

Burst-shaping errors are not linear and cannot be removed by applying equalization.

4. Summary

Conformance measurements are performed to verify that a digital transmitter design meets system requirements. If the transmitter does not comply with the specifications, the problem must be tracked down to the impaired device or section.

This application note has presented the most common transmitter measurements and a general methodology for troubleshooting transmitter problems. A link between the different transmitter measurements and the most common impairments has also been established. With these tools and adequate measurement equipment, you will be able to quickly recognize and verify problems in your design.

Appendix A: Detailed Troubleshooting Procedure

Figure 76.
Troubleshooting
procedure

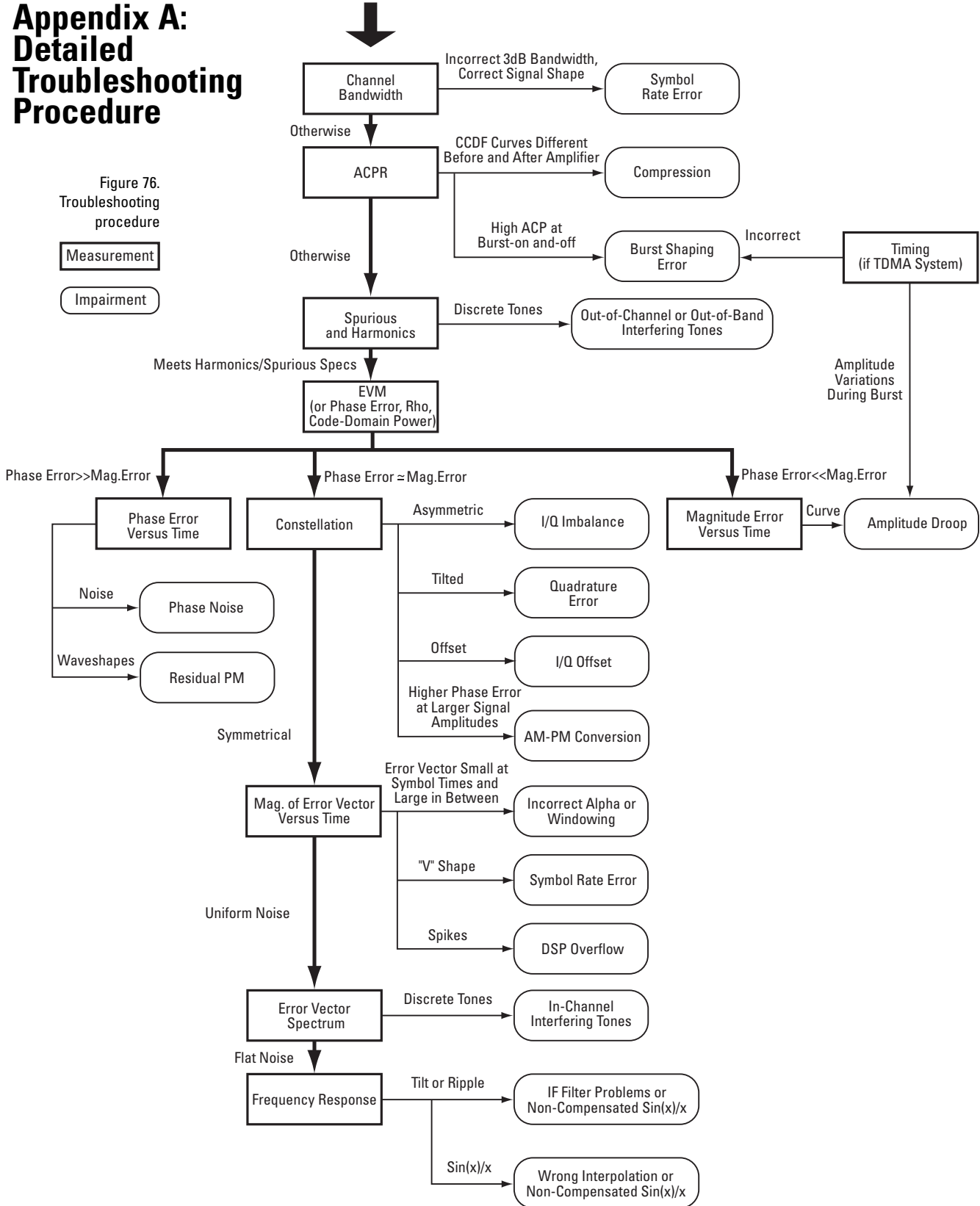
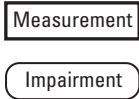

Appendix B: Instrument Capabilities

The following table shows the current capabilities of Agilent Technologies vector signal analyzers and spectrum analyzers for testing and troubleshooting digital communications transmitter designs. Measurements are not specific to a particular standard unless otherwise noted.

Measurement and Troubleshooting Capabilities	Vector Signal Analyzers			Spectrum Analyzers		
	89600	89400 Series ¹	E4406A Series transmitter tester ²	8590 E-Series with measurement personality ³	8560 E-Series ¹	ESA-E Series ¹
Carrier frequency	●	●	●	●	●	●
Channel bandwidth	●	●	●	●	●	●
Channel power	●	●	●	●	●	●
Occupied bandwidth	●	●	● ⁵	●	●	●
Peak-to-average	●	●	●	● ⁴		
CCDF	●	●	●			
ACPR (or equivalent)	●	●	●	●	●	●
In-band spurious	●	●	●	●	●	●
Out-of-band spurious/harmonics	Up to 2.7 GHz	Up to 2.65 GHz	Up to 4 GHz ⁶	●	●	●
Timing	●	●	●	●	●	●
EVM or phase error (% rms)	●	●	●	●		● ¹⁰
Magnitude of error vector or phase error (versus time)	●	●	●			
Error vector spectrum	●	●				
Rho	●	●	●			●
Code-Domain Power		● ⁷	●			● ⁴
Equalizer (bits-to-RF frequency & group delay)	●	●		● ⁹		
Polar and constellation	●	●	●	●		● ⁴
Eye or Trellis diagram	●	●		●		
Symbol table	●	●	● ⁸	●		
Sync. word as trigger	●	●	●	●		● ¹⁰
Inverted (mirror) frequency mode		●	● ¹¹			● ¹¹
Baseband I and Q inputs	●	●				
Mathematical functions	●	●				
Time capture	●	●				
Spectrogram		●				
Analog PM or FM demodulation	●	●		●		●

1. Measurement personalities and/or options might be required to perform some of the measurements.
2. Measurements pre-configured for cdmaOne, GSM, NADC, PDC, W-CDMA and cdma2000 and iDEN.
3. Measurements pre-configured for specific wireless systems, depending on the measurement personality used: GSM, cdmaOne, NADC, PHS, PDC, or DECT.
4. Only available for cdmaOne.
5. Only available for PDC.
6. Manual search required. No input signal image protection.
7. Only available for W-CDMA.
8. Only available for GSM.
9. Only available for DVB-C (Digital Video Broadcast-Cable) with the appropriate measurement personality.
10. Only available for cdmaOne and GSM.
11. Only available for Code-Domain Power measurement.

5. Glossary

3G	Third Generation
ACP	Adjacent Channel Power
ACPR	Adjacent Channel Power Ratio
bits-to-RF frequency response	Frequency response from baseband to RF, using bits as the stimulus signal
BW	Bandwidth
CCDF	Complementary Cumulative Distribution Function
CDMA	Code Division Multiple Access
cdmaOne	IS-95 standard-based CDMA system
cdma2000	cdmaOne derivative, 3G system
CMOS	Complementary Metal Oxide Semiconductor
DAC	Digital-to-Analog Converter
DECT	Digital Enhanced Cordless Telephone
DSP	Digital Signal Processor or Digital Signal Processing
DVB-C	Digital Video Broadcast - Cable
EVM	Error Vector Magnitude
FFT	Fast Fourier Transform
FIR	Finite Impulse Response
FM	Frequency Modulation
frame	In TDMA systems, a repeating time interval divided among multiple users (see timeslot)
GSM	Global System for Mobile communications
GMSK	Gaussian Minimum Shift Keying
IF	Intermediate Frequency
I/Q	In-phase/Quadrature
ISI	Intersymbol Interference
LMDS	Local Multipoint Distribution System
LO	Local Oscillator
MSB	Most Significant Bit
NADC	North American Digital Cellular system
OQPSK	Offset Quadrature Phase Shift Keying
ORFS	Output RF Spectrum
PA	Power Amplifier
PDC	Pacific Digital Cellular system
PHS	Personal Handyphone System
PM	Phase Modulation
RF	Radio Frequency
SA	Spectrum Analyzer
SAW	Surface Acoustic Wave
TDMA	Time Division Multiple Access
timeslot	In TDMA systems, amount of time per frame each mobile has to transmit information (see frame)
VSA	Vector Signal Analyzer
Walsh code	Orthogonal code used in cdmaOne systems for channelization in the forward link and as orthogonal modulation in the reverse link
W-CDMA	Wideband CDMA, 3G system

6. References

- [1] *Digital Modulation in Communications Systems*, Application Note 1298, literature number 5965-7160E.
- [2] *Understanding CDMA Measurements for Base Stations and Their Components*, Application Note 1311, literature number 5968-0953E.
- [3] *Understanding GSM Transmitter Measurements for Base Transceiver Stations and Mobile Stations*, Application Note 1312, literature number 5968-2320E.
- [4] *Understanding PDC and NADC Transmitter Measurements for Base Transceiver Stations and Mobile Stations*, Application Note 1324, literature number 5968-5537E.
- [5] *Testing and Troubleshooting Digital RF Communications Receiver Designs*, Application Note 1314, literature number 5968-3579E.
- [6] *Power Statistics of Digitally Modulated Signals*, Pete Watridge, Wireless Symposium, 1999.
- [7] *Adaptive Equalization and Modulation Quality*, Bob Cutler, Hewlett-Packard Wireless R&D Seminar, 1997.
- [8] *Spectrum Analyzer Measurements and Noise*, Application Note 1303, literature number 5966-4008E.

7. Related Literature

1. *Using Vector Modulation Analysis in the Integration, Troubleshooting and Design of Digital RF Communications Systems*, Product Note 89400-8, literature number 5091-8687E.
2. *Using Error Vector Magnitude Measurements to Analyze and Troubleshoot Vector-Modulated Signals*, Product Note 89400-14, literature number 5965-2898E.
3. *89400 Series Vector Signal Analyzers*, literature number 5965-8554E.
4. *VSA Series Transmitter Tester*, literature number 5966-4762E.
5. *8560 E-Series Spectrum Analyzers*, literature number 5966-3559E.
6. *8590 E-Series Spectrum Analyzers*, literature number 5963-6908E.
7. *ESA-E Series Spectrum Analyzers*, literature number 5968-3278E.

Agilent Technologies' Test and Measurement Support, Services, and Assistance

Agilent Technologies aims to maximize the value you receive, while minimizing your risk and problems. We strive to ensure that you get the test and measurement capabilities you paid for and obtain the support you need. Our extensive support resources and services can help you choose the right Agilent products for your applications and apply them successfully. Every instrument and system we sell has a global warranty. Support is available for at least five years beyond the production life of the product. Two concepts underlay Agilent's overall support policy: "Our Promise" and "Your Advantage."

Our Promise

Our Promise means your Agilent test and measurement equipment will meet its advertised performance and functionality. When you are choosing new equipment, we will help you with product information, including realistic performance specifications and practical recommendations from experienced test engineers. When you use Agilent equipment, we can verify that it works properly, help with product operation, and provide basic measurement assistance for the use of specified capabilities, at no extra cost upon request. Many self-help tools are available.

Your Advantage

Your Advantage means that Agilent offers a wide range of additional expert test and measurement services, which you can purchase according to your unique technical and business needs. Solve problems efficiently and gain a competitive edge by contracting with us for calibration, extra-cost upgrades, out-of-warranty repairs, and on-site education and training, as well as design, system integration, project management, and other professional services. Experienced Agilent engineers and technicians worldwide can help you maximize your productivity, optimize the return on investment of your Agilent instruments and systems, and obtain dependable measurement accuracy for the life of those products.

Online and Phone assistance:

www.agilent.com/find/assist

United States: (tel) 1 800 452 4844

Product specifications and descriptions in this document subject to change without notice.

Copyright © 2000 Agilent Technologies

Printed in USA 4/00

5968-3578E



Agilent Technologies

Innovating the HP Way