

# Pulsed Characterization of Power Semiconductors Using Electronic Loads

## Application Note 1246

### Electronic Load Improves Power Semiconductor Measurements

An electronic load eliminates the self-heating problems associated with measuring the on-state voltage drop and transconductance (or current gain) of power semiconductors.

On-state voltage drop and transconductance (or current gain) of power FETs, BJTs, and IGBTs are temperature dependent, but are typically specified at 25°C. However, it is difficult to obtain an accurate measurement of these parameters because the manufacturer's test conditions can cause the device to dissipate significant peak power, which will raise the device temperature above 25°C. Sometimes the amount of peak power exceeds the device's static power rating by nearly 6:1! For example, an IRF540 FET is rated at 150W continuous, but the transconductance  $g_{fs}$  is specified at a test condition of 17A and 50V, or 850W. If the device is subjected to this test condition too long it will self-heat, and its junction temperature will no longer be 25°C, so measurements will be inaccurate.

#### Electronic Loads

An electronic load (see figure) employs a power MOSFET as an electronically variable load that dissipates power. The electronic load senses MOSFET current ( $I_{IN}$ ), then amplifies it, compares it with a reference, and feeds back the output of an error amplifier to the MOSFET gate. This forms a closed-loop current control system. Therefore, the electronic load's input current ( $I_{IN}$ ) is proportional to the control reference input. Input current,  $I_{IN}$ , loads the DC power source (battery or power supply).

Given a fixed control reference, the load acts as a series current regulator. If the control reference is proportional to the load input voltage ( $V_{IN}$ ), the load behaves like a high quality power resistor. Some load manufacturers also offer a constant voltage regulation mode in which the load behaves like a power zener diode.

Both tests performed in this application use the electronic load's constant current mode, which is usually its highest performance mode. Applying the desired pulse waveform to the load's control reference input produces the pulsed input ( $I_{IN}$ ).

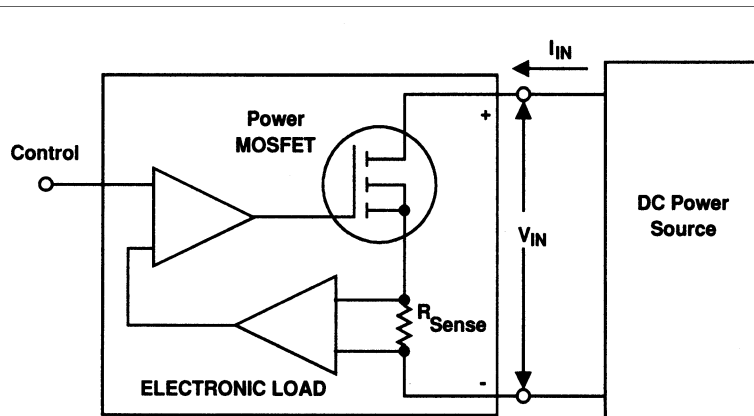

Most manufacturers minimize this problem by characterizing parts with an 80µsec (or 300µsec) current pulse. If an IRF540 FETs measured at 40µsec after power is applied, the transient thermal impedance is only 2% of its 1°C/W DC rating. This yields a junction-to-case (J-C) temperature rise of only 0.4°C for measuring  $R_{ds(on)}$  at 17A (22W peak), but still yields a J-C rise of 17°C when measuring  $g_{fs}$  (850W peak). It is not hard to see why pulsed current measurements are necessary. The narrower the pulse and faster the measurement, the more accurate the results.

$R_{ds(on)}$  is specified at a particular drain current with a fixed gate voltage. To measure  $R_{ds(on)}$ , bias the gate with a voltage source, pulse the drain with rated current, and measure the drain voltage.  $R_{ds(on)}$  is then  $V_{ds}/I_d$ . For the  $R_{ds(on)}$  test, a high current pulse generator with programmable amplitude, pulse width, repetition rate, preferably programmable rise/fall time, with adequate voltage compliance is needed. A low power voltage source to set the device under test (DUT) gate voltage is also needed. Drain voltage is measured at roughly the mid-point in time of the drain current pulse, and the ratio of drain voltage to current is  $R_{ds(on)}$ .

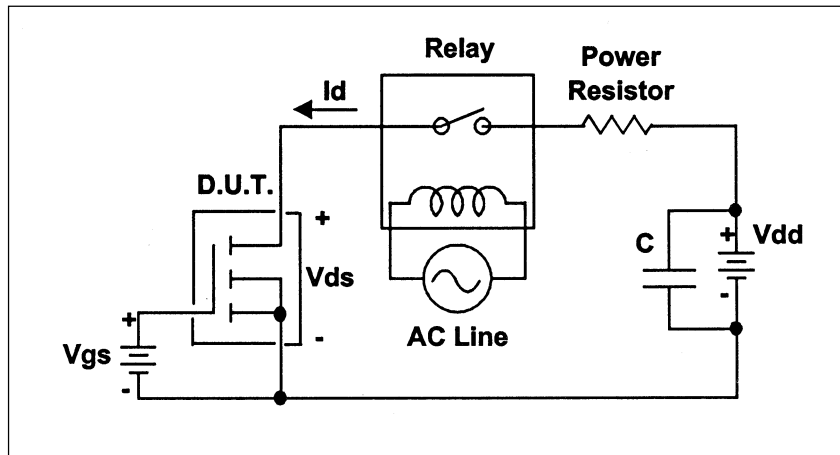

Figure 1. Current pulse generator using a relay switch for parameter measurement.

The device transconductance  $g_{fs}$  is specified as the incremental drain current that results from an incremental increase in gate voltage, at a specified operating drain current. One method of measuring  $g_{fs}$  would be to pulse the gate voltage, apply a static voltage bias to the drain, and measure the pulsed drain current. An alternate method is to apply a static bias to the gate with the same voltage source as before, apply a pulsed voltage bias to the drain, and measure the drain current. For either method DUT gate voltage is incremented up from the threshold voltage ( $V_t$ ), and drain current measured at roughly the mid-point of the pulse until reaching the specified test current.  $G_{fs}$ , the change in drain current for a small change in gate voltage is then measured by taking two subsequent measurements, and computing  $G_{fs} = \Delta I_d / \Delta V_{gs}$ .

## Generating High Current Pulses

At low power levels, self-contained instruments called SMU's (stimulus-measurement units) are readily available for semiconductor device characterization. At high power levels, two alternate methods to construct SMU-equivalent systems can be considered.

An inexpensive, but limited and not very well-controlled method of generating current pulses is to use a relay as a switch to connect a voltage source ( $V_{dd}$ ), current-limiting power resistor, and the DUT in series as shown in Figure 1.

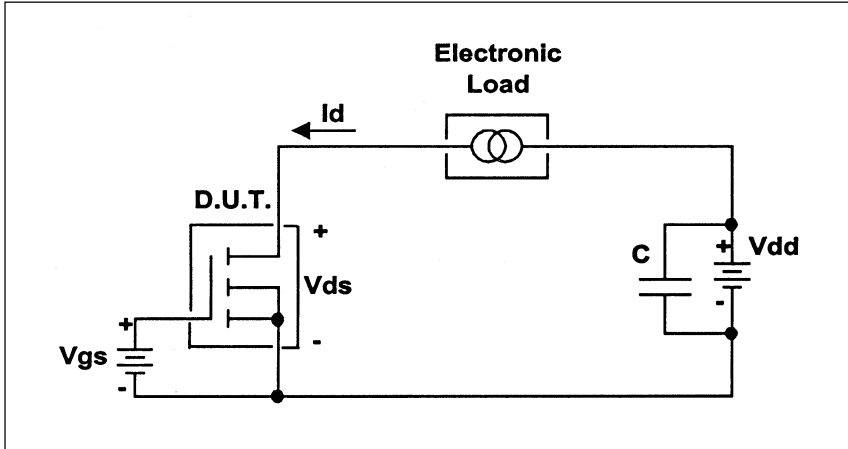

**Figure 2. Electronic Load measurement system.**

An external filter capacitor may be required across the power supply to minimize voltage droop during the high current pulse interval. The relay is a mercury-wetted type for fast switching and low contact bounce. It is alternately closed and opened at a low repetition rate (typically 60Hz). The circuit is designed to produce a 300 $\mu$ sec test pulse. One disadvantage of this implementation for the  $R_{ds(on)}$  measurement is that the test current is dependent on power supply voltage and power resistor value. Therefore, the resistor and possibly the power supply voltage need to be reselected for each test current condition. This is a laborious approach to obtain a full set of device characterization data. In addition, resistance temperature coefficient and stability can be significant error sources at these power levels. Also, relay contacts may wear and fail prematurely when subjected to repeated high current stresses.

In Figure 2 the relay and resistor combination from Figure 1 are replaced by an electronic load. The voltage source,  $V_{dd}$  is retained to create a pulsed constant current source.

An advantage of this approach is that the electronic load can be reprogrammed for various test currents without rewiring the circuit. The test current can be set much more accurately and exhibits little or no temperature dependence or drift, and there are no mechanical parts to wear out. In addition, other test current attributes, such as rise time, can be programmed to virtually eliminate the effect of parasitic wiring inductance on test results. Much narrower pulse widths and variable repetition rates within the electronic load's specifications, can be generated.

Most electronic loads also offer a "current monitor" signal that produces an analog voltage proportional to the current drawn. This signal may be used directly for the current measurement, rather than having to add an accurate, high current shunt or current probe.

### Measuring $R_{ds(on)}$

Apply the test set-up in Figure 2 to measure  $R_{ds(on)}$  of an IRF540 power MOSFET. The same technique applies for measuring  $V_{ce(on)}$  for an IGBT, or  $V_{ce(sat)}$  for a BJT (with the  $V_{gs}$  power supply replaced by a current source for the BJT). The gate power supply is set for the specified 10V test condition, so the DUT exhibits a low drain-to-source impedance, and the electronic load controls the current drawn from the drain power supply ( $V_{dd}$ ). Programmed for its constant current, triggered transient pulse mode, the electronic load generates a 17A, 80 $\mu$ sec pulse with a 2.5A/ $\mu$ sec current slew rate. Trigger commands are sent over HP-IB from a BASIC program at a 5Hz rep rate to keep static power dissipation so low (8mW) that the test could be run in free air with no heat sink.

The power supply voltage ( $V_{dd}$ ) allows enough voltage drop for the DUT on-state voltage of  $I_d * R_{ds(on)}$ , the minimum required load operating voltage. This is the voltage needed to drive the wiring inductance and any supply voltage droop occurring over the pulse width.

$$V_{dd} = I_d * R_{ds(on)} + V_{load} + L \cdot di/dt + \text{droop}$$

The  $I_d * R_{ds(on)}$  term is less than 2V at the 17A test condition. The HP 6060B electronic load is specified at 3V minimum for AC operation. Allowing for as much as 1μH wiring inductance with 2.5A/μsec slew rate, requires 2.5V for the  $L \cdot di/dt$  term.

Assuming the power supply is too slow to respond to the instantaneous high current demand, the required filter capacitor value to limit the supply voltage droop term to 2V would be  $C = (I_d * tw) / \Delta V = 17A * 80\mu\text{sec} / 2V = 680\mu\text{F}$ . The HP 6032B power supply chosen had adequate internal filter capacitance, so no external filter capacitance was required.  $V_{dd}$  is programmed to 10V for the test because the total required minimum power supply voltage was 9.5V.

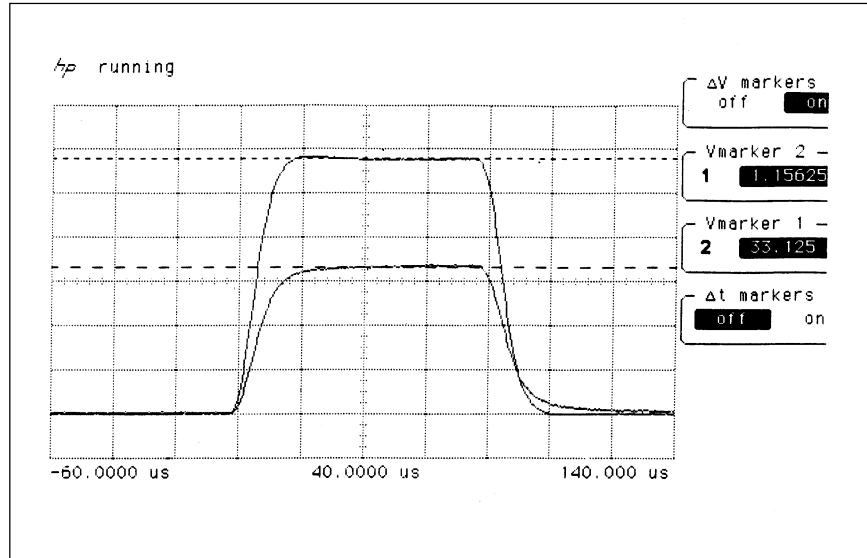

**Figure 3.**  
 $V_{ds}$  and  $I_d$  measurement waveforms,  
 gate  $V=10V$ ,  
 top trace:  $V_{ds}$  at 200 mV/div,  
 bottom trace:  $I_d$  at 5A/div,  
 time base: 20psec/div.

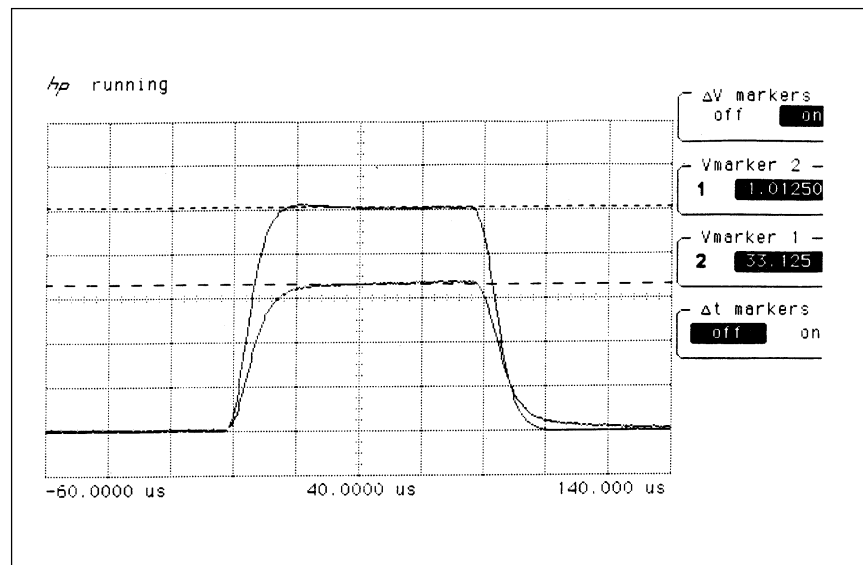

**Figure 4.**  
 $V_{ds}$  and  $I_d$  measurement waveforms,  
 gate voltage=15V,  
 top trace:  $V_{ds}$  at 20mV/div,  
 bottom trace:  $I_d$  at 5A/div,  
 time base: 20psec/div.

Current was first monitored with a Tektronix AM 503 P6302 current probe amplifier to verify overall operation. It was not found necessary for this test because the electronic load settled within 20µsec.  $V_{ds}$  was monitored at the DUT and fed to an HP 54503A digitizing oscilloscope. Figure 3 shows the actual waveforms.  $R_{ds(on)}$  measured 71 mOhms for this test sample. The typ/max  $R_{ds(on)}$  from the IR data sheet is 60/70 mOhms for this part, so actual test results fall within the expected range of values.

The test was then rerun on the same test device with the gate voltage raised from the specified 10 to 15V, and  $R_{ds(on)}$  dropped from 71 to 66 mOhms (Figure 4).  $R_{ds(on)}$  vs  $I_d$  plots for a fixed gate voltage could also be conveniently acquired with this test setup. This would allow a power supply designer to understand how much quantitative thermal benefit has been gained by driving a MOSFET switch at a somewhat higher gate voltage. It would also show what actual losses are to be expected at the actual circuit drain current. Even if relatively short twisted-pair leads are used, by-pass capacitors are necessary from drain-source and gate-source to prevent very high frequency parasitic oscillations due to test lead length. Figure 5 shows the actual bypass scheme used.

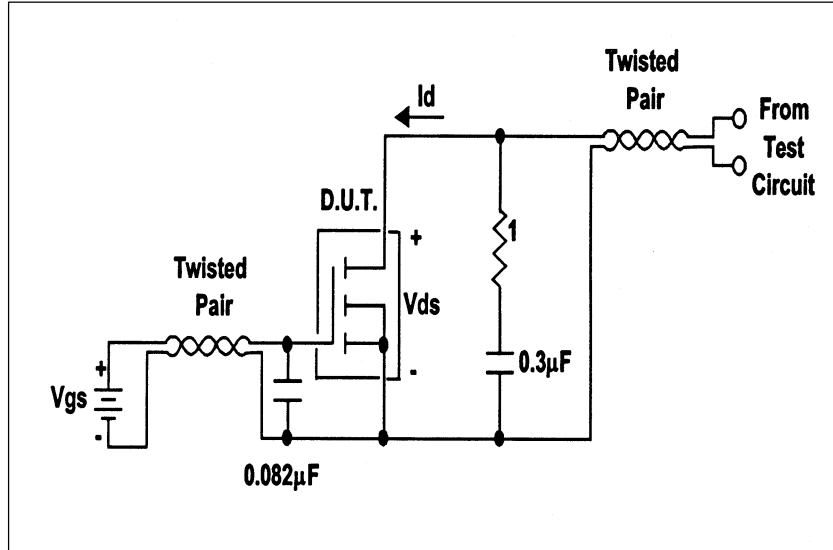

**Figure 5.**  
Capacitor  
bypass circuit.

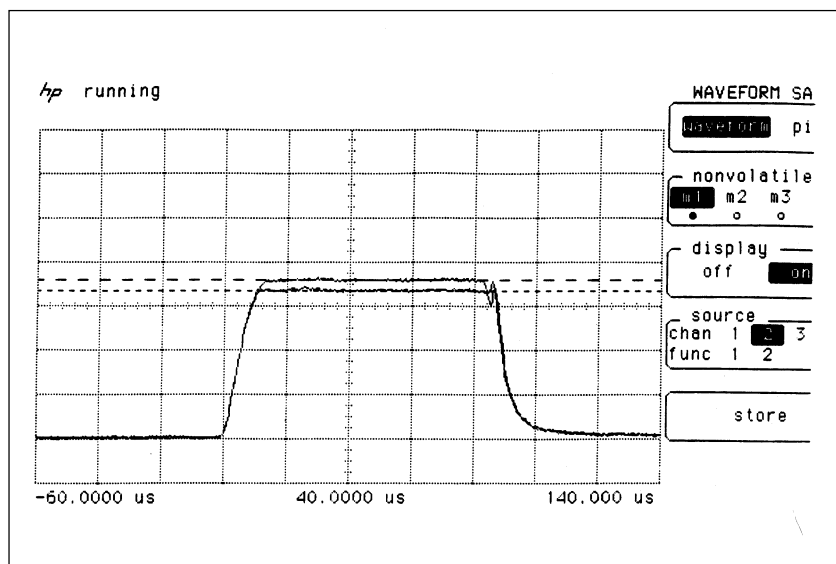

**Figure 6.**  
Drain current,  
top trace:  $I_{d2}$ ,  
bottom trace:  $I_{d1}$ ,  
top/bottom trace: 5A/div,  
time base: 20µsec/div.

## Measuring $G_{fs}$

Use the same test set-up given in Figure 2 to measure  $g_{fs}$  for the IRF540 power MOSFET. This technique can be applied to measuring  $g_{fe}$  for an IGBT, and  $h_{fe}$  for a BJT as well (with the  $V_{gs}$  power supply replaced by a current source for the BJT). Use the second  $g_{fs}$  test method described earlier.

For the  $g_{fs}$  test, the electronic load is essentially used as a switch, to apply a pulsed drain voltage ( $V_{dd} - V_{load}$ ). A gate voltage is established, and the DUT itself determines the current that flows based on its threshold voltage and transconductance. To cause the electronic load to act as a switch, program its current somewhat above the test current. For example, 22A for a 17A test current. This forces the load into an unregulated condition, where it asks to draw more current than the DUT will allow. Slew rate was set at 5A/ $\mu$ sec for this test.

To measure  $g_{fs}$  at the specified test current and drain voltage it is necessary to first iterate to find the  $V_{gs}$  that produces the desired test current for this particular DUT.  $V_{gs}$  is incremented up from the threshold voltage ( $V_t$ ) until the desired test current ( $I_{d1}$ ) is reached at a given  $V_{gs}$  ( $V_{gs1}$ ). Then  $V_{gs}$  is incremented again and a higher  $I_d$  ( $I_{d2}$ ) results. Computing  $g_{fs}$ :

$$g_{fs} = \frac{(I_{d2} - I_{d1})}{V_{gs2} - V_{gs1}}$$

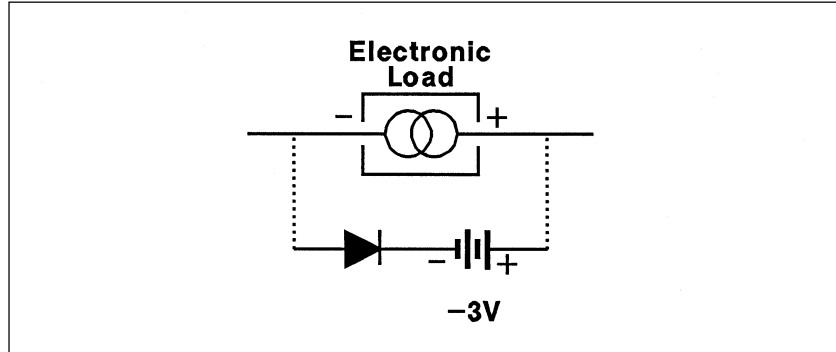

**Figure 7.**  
Power supply and diode combination.

For the IRF540,  $V_{gs2}$  measured 6.0V for the test current of 17.9A, and  $V_{gs1}$  measured 5.9V, at a drain current of 16.7A.  $G_{fs}$  was then computed as roughly 12, which again agrees quite well with the mini typ values of 8/13 given in the IRF540 data sheet. Figure 6 shows oscilloscope waveforms for both drain current conditions.

## Practical Considerations

To keep from momentarily exceeding the maximum power rating of the 300W electronic load, set the power supply voltage ( $V_{dd}$ ) to 30V rather than 50V for the  $g_{fs}$  test. The drainsource bypass capacitance (Figure 5), added to prevent high-frequency oscillation of the DUT, limits how fast the drain voltage can increase. Therefore, it places the maximum voltage across the electronic load with full current for the first part of each test pulse (approximately 20 $\mu$ sec for test conditions listed). Because  $g_{fs}$  is a very weak function of  $V_{ds}$ , testing at the lower  $V_{ds}$  had no significant effect on the test results. This was confirmed by observing no change at all in drain current when varying  $V_{ds}$  from 20 to 50V.

To keep the load voltage above its minimum specified operating voltage, connect a power supply and diode combination (Figure 7) across the electronic load for the  $g_{fs}$  test. The load functions as a switch for this test, unlike the  $R_{ds(on)}$  test where the load itself regulates the DUT current. Actual pulse-width will exceed programmed pulse-width by approximately 15 $\mu$ sec if the HP 6060B load voltage falls below its minimum voltage specification. This occurs because the load becomes unregulated, and takes some additional time to recover from this condition. Depending on how accurate pulsewidth control needs to be, the additional power supply and diode combination may be eliminated with no other observed side effects.

---

Some necessary attributes of the electronic load are:

- Minimal overshoots and undershoots
- Triggered or continuous programmable pulse generation
- Graceful recovery from being driven unregulated during the  $g_{fs}$  test (if the additional power supply and diode combination shown in Figure 7 are not used).
- Programmable current slew rate, which allows control over  $L di/dt$  voltage spikes and minimizes ringing
- Rated for the peak power it sees during the test

For the  $R_{ds(on)}$  test, peak power can be minimized by setting the drain voltage supply ( $V_{dd}$ ) fairly low. For the  $g_{fs}$  test, the load only sees peak power during the transitions, because the DUT itself sees full power during measurement. Peak load power can be minimized by minimizing test lead lengths and inductance, so a small drain bypass capacitor can be used (Figure 5).

Other useful Load features are an "Imon" analog current port so that a separate current shunt or current probe is not required. However, some flexibility is lost when using the internal load shunt, because measurement common constraints and fixture bypass capacitor currents (Figure 5) needs to be considered. A trigger-out feature for test stimulus and measurement synchronization is useful, though the trigger features on the oscilloscope used were adequate. A load trigger-in feature allows another load to be used to create pulsed rather than static base current for testing BJTs. This is synchronized with the collector test current, thereby minimizing heating in both the base and collector regions of the DUT. The HP 6060B load used for these tests had both the necessary and useful features, and all required performance attributes. As seen in Figures 3, 4, and 6, current and voltage waveforms are particularly clean and well-controlled, making it possible to perform the desired pulsed measurements.

For more information about Hewlett-Packard power products, please ask your local Hewlett-Packard Sales Representative for a copy of the DC Power Products Catalog, HP P/N 5091-6205. To help you choose a dc power supply for an ATE application, please also ask for a copy of "12 Factors to Consider When Choosing a System Power Supply" HP P/N 5952-4199.

Your local HP Sales Office is listed in your telephone directory white pages.

---

For more information about Hewlett-Packard Test and Measurement products, applications, services, and for a current sales office listing, visit our web site, <http://www.hp.com/go/tmdir>. You can also contact one of the following centers and ask for a test and measurement sales representative.

**United States:**

Hewlett-Packard Company  
Test and Measurement Call Center  
P.O. Box 4026  
Englewood, CO 80155-4026  
1 800 452 4844

**Canada:**

Hewlett-Packard Canada Ltd.  
5150 Spectrum Way  
Mississauga, Ontario  
L4W 5G1  
(905) 206 4725

**Europe:**

Hewlett-Packard  
European Marketing Centre  
P.O. Box 999  
1180 AZ Amstelveen  
The Netherlands  
(31 20) 547 9900

**Japan:**

Hewlett-Packard Japan Ltd.  
Measurement Assistance Center  
9-1, Takakura-Cho, Hachioji-Shi,  
Tokyo 192, Japan  
Tel: (81-426) 56-7832  
Fax: (81-426) 56-7840

**Latin America:**

Hewlett-Packard  
Latin American Region Headquarters  
5200 Blue Lagoon Drive  
9th Floor  
Miami, Florida 33126  
U.S.A.  
(305) 267 4245/4220

**Australia/New Zealand:**

Hewlett-Packard Australia Ltd.  
31-41 Joseph Street  
Blackburn, Victoria 3130  
Australia  
1 800 629 485

**Asia Pacific:**

Hewlett-Packard Asia Pacific Ltd  
17-21/F Shell Tower, Times Square,  
1 Matheson Street, Causeway Bay,  
Hong Kong  
Tel: (852) 2599 7777  
Fax: (852) 2506 9285

Data subject to change  
Copyright © 1993  
Hewlett-Packard Company  
Printed in U.S.A. 6/93  
**5091-7636E**