

# Low On-Resistance Solid-State Relays For High-Reliability Applications

## Application Note 1047

In military, aerospace, and commercial applications, the high performance, long lifetime, and immunity to shock and vibration give solid-state relays distinct advantages over electro-mechanical relays. The HSSR-7110 family of hermetically sealed power MOSFET optocouplers operate exactly like single-pole, normally-open, solid-state relays (SSR). Therefore, from here on, they will be referred to as SSRs. Each SSR in the HSSR-7110 family contains a light-emitting diode (LED) optically coupled to a high voltage circuit. When a control current flows through the input terminals of the SSR, the LED emits light onto a photodiode

array. This photodiode array, illustrated in Figure 1, generates sufficient voltage and current to operate a FET driver circuit and also to drive the gate-to-source voltages above the thresholds of the two output MOSFETs. This application note describes the main characteristics of the HSSR-7110, suggests various control drive circuits, and discusses the use of this SSR with different types of loads. Additional information regarding SSRs and their applications can be found in Hewlett-Packard's Application Notes 1036 and 1046.

### Summary of Characteristics

The HSSR-7110 is in a hermetically sealed, eight-pin, dual in-line package. It is specified over the full military operating temperature range, from -55 to +125°C. The four output pins of the SSR can be configured as either Connection A or Connection B, as shown in Figure 2. With Connection A, the signal at the output of the SSR can have either positive or negative polarity. This means that the SSR can switch either ac or dc signals. With Connection B, the

signal at the output of the SSR must have its polarity as indicated in Figure 2b. In this configuration, pins 5 and 8 are tied together and the SSR can control dc signals only. An advantage of using Connection B is that it places the two output FETs in parallel with each

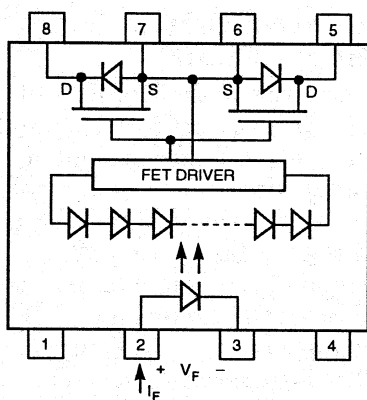

Figure 1. Circuit Diagram of HSSR-7110.

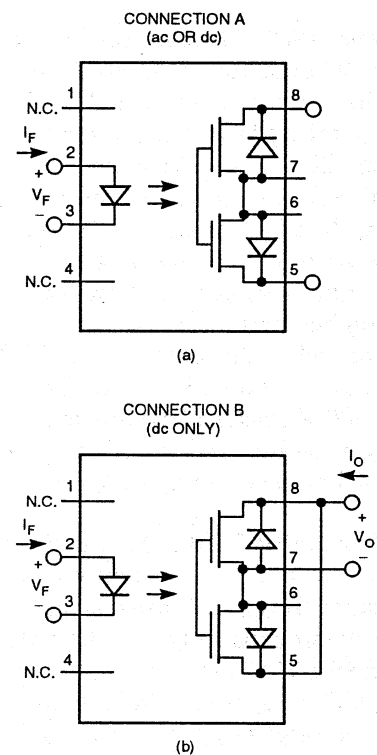

Figure 2. HSSR-7110 Schematic.

other, rather than in series. This configuration reduces the output on-resistance of the SSR significantly and increases its output current capability by a factor of two. Figure 2 also defines the polarity for the input side of the SSR. The HSSR-7110 turns on (its contact closes) with a minimum input current,  $I_F$ , of 5 mA at a typical forward voltage,  $V_F$ , of 1.24 V. Operation at higher currents causes faster closure of the contacts. The SSR turns off (its contact opens) when  $V_F$  is equal to 0.6 V or less.

Each HSSR-7110 is tested to and passes a momentary input-to-output withstand test of 1500 Vdc for 5 seconds. Additionally, the HSSR-7110 has a minimum output transient rejection of 1000 V/ $\mu$ s and a minimum input-to-output transient rejection of 500 V/ $\mu$ s.

The HSSR-7110 has an output withstand voltage of 90 V over the entire recommended operating temperature range. If the SSR is used to switch ac signals, as shown in Connection A, then 90 V is the maximum amount of peak positive or negative voltage that should be applied across the output contact. Additionally, the HSSR-7110 can be subjected to the  $\pm 600$  V electrical system spike test defined in MIL-STD-704A without sustaining damage.

The HSSR-7110 is distinguished by its small size, low on-resistance,  $R_{(on)}$ , and large output current capability,  $I_O$ . A typical HSSR-7110 measures 8.13 mm (0.32 in) by 9.90 mm (0.38 in) and weighs approximately 0.7 gram. At room temperature, with Connection A, the typical on-resistance of the HSSR-7110

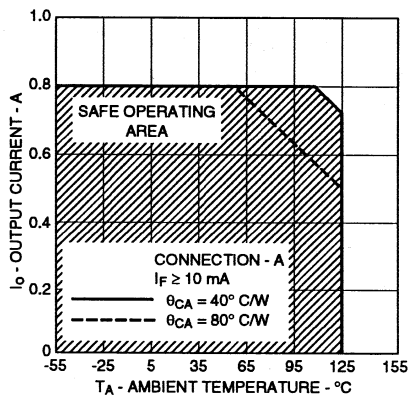

Figure 3. HSSR-7110 Output Current Derating Graph.

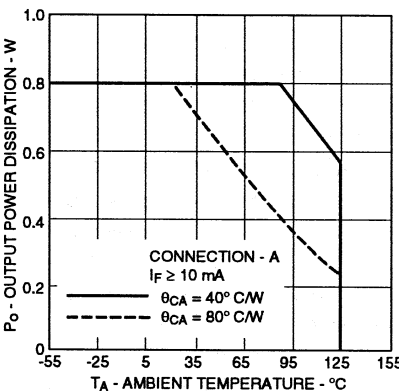

Figure 4. Output Power Dissipation vs. Temperature.

is 0.4 ohm, and the average output current rating is 0.8 A (5 A, surge). With Connection B, the on-resistance is reduced to 0.12 ohm and the average output current rating is increased to 1.6 A (10 A, surge). As mentioned in the data sheet, the on-resistance specification for the HSSR-7110 refers to the resistance measured across the output contact when a pulsed current signal is applied to the output pins. The use of a pulsed signal ( $\leq 30$  ms) implies that each junction temperature is equal to the ambient and case temperatures.

The output current rating of an electromechanical relay (EMR) is usually limited by its ability to interrupt that current when opening. The output current rating of the HSSR-7110, on the

other hand, is limited by the highest junction temperature ( $150^{\circ}\text{C}$ ) its MOSFETs can withstand. This junction temperature is a function of the on-resistance, the load current, the thermal resistances, and the ambient temperature. As the junction temperature rises, the on-resistance also rises. To limit power dissipation at higher temperatures, the output current rating must be derated. It is important for SSR specifications to include this derating effect. The HSSR-7110 data sheet includes a graph (Figure 3) that shows the effect of temperature on the output current rating,  $I_O$ .  $\theta_{CA}$ , as referenced on the graph, is the case-to-ambient thermal resistance. This parameter depends on the conditions of the board design and is, therefore, determined by the designer. If the SSR is operated within the "Safe Operating Area" indicated on the current derating graph, the corresponding "Output Power versus Temperature" graph (Figure 4) illustrates the maximum amount of power dissipated by the SSR. Operation within the safe operating area ensures that the steady-state junction temperature will remain below  $150^{\circ}\text{C}$ .

## Control Drive Circuit Suggestions

Operation of the HSSR-7110 requires at least 5 mA of input current. A larger amount of input current, however, results in faster turn-on of the SSR and a slightly faster turn-off. A simple circuit for obtaining the desired ON current and OFF voltage is shown in Figure 5. The logic series used can be either TTL or CMOS, as long as the current-sinking capability is adequate. Resistor  $R_1$  sets the

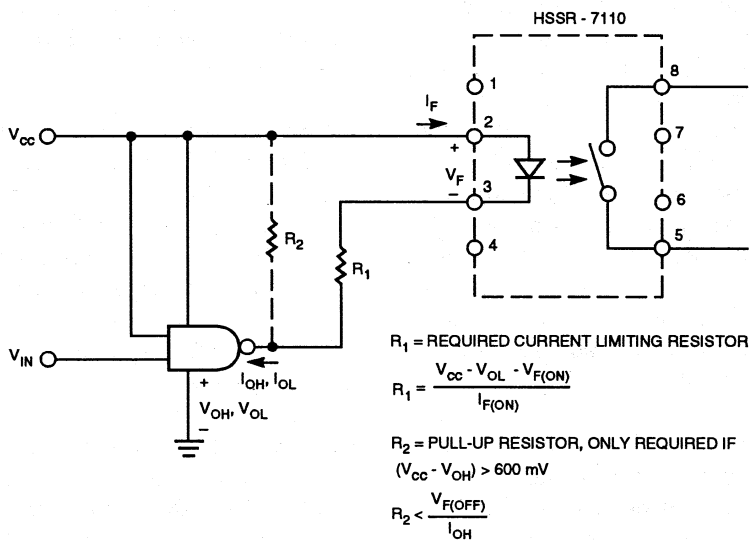

Figure 5. Recommended Drive Circuit.

level of steady-state input current,  $I_F$ . The purpose of  $R_2$  is to bypass logic-high leakage current with sufficiently small voltage drop to ensure an OFF-voltage less than 0.6 V.  $R_2$  is not required if the logic output has an internal pullup circuit that is able to satisfy the OFF-voltage requirement of the SSR. With open-collector TTL outputs,  $R_2$  is always required to ensure that  $V_{F(OFF)} < 0.6 \text{ V}$ .

Another drive circuit that can be used with an open-collector TTL gate is shown in Figure 6. Here, the LED is switched off by directing current away from it with the shunt output transistor within the gate. When the output of the 74S05 goes low, current is shunted away from the LED, and the SSR turns off. When the output of the 74S05 goes high, the steady-state input current,  $I_F$ , is limited by  $R_1$ . For open collector gates, this configuration eliminates the extra pull-up resistor,  $R_2$ , required by the circuit shown in Figure 5.

### Control Status

Essentially, the resistors  $R_1$  and  $R_2$  of Figure 5 together serve as an "input buffer" for the HSSR-7110, making the SSR compatible with either TTL or CMOS. In some applications, a designer may need to monitor the status of the input control side of the SSR. To implement such an external "control status" feature, one of the unused gates in the NAND-gate package can be connected as shown in Figure 7. When the input voltage  $V_{IN}$  goes high, the status output,  $V_{STATUS}$ ,

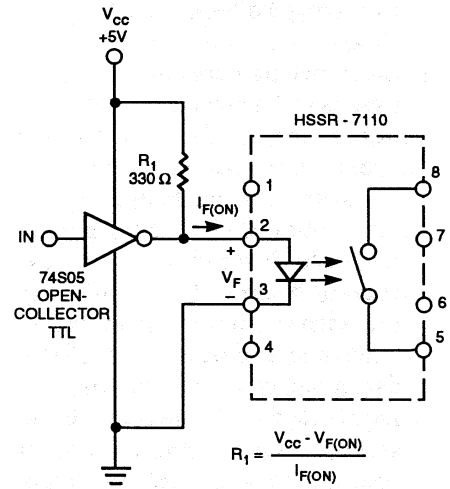

Figure 6. Shunt Drive Circuit.

also goes high ( $V_{OH}$ ). When the input voltage  $V_{IN}$  goes low, the status output,  $V_{STATUS}$ , also goes low ( $V_{OL}$ ).

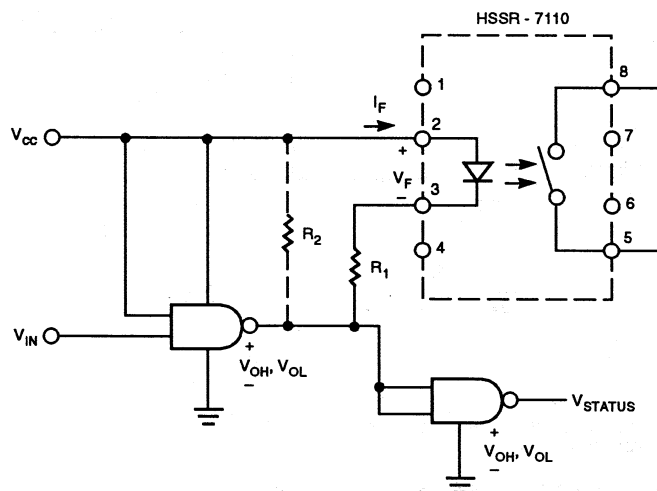

Figure 7. Control Status Output.

### Peaking To Shorten Turn-on Time

As mentioned earlier, turn-on time is influenced by the level of input current. As input current is increased, the turn-on time becomes shorter. However, it may not be desirable to operate with a high steady-state input current because that would increase the input power consumption and accelerate LED degradation. In situations requiring fast turn-on but low steady-state current, the optional peaking circuit shown in Figure 8 can be used. When the logic output is high,  $R_2$  assures that the current through the LED is

$R_3$ ( $\Omega$ )	$I_F(\text{PEAK})$ (mA)	$t_{\text{ON}}$ (ms)
—	10 (No Peak)	2.0
330	20	1.0
100	40	0.48
33	100	0.22

Table 1. Typical Peaked Turn-On Times

so small that the capacitor is completely discharged. Then, when the logic output goes low, a surge of current flows through both  $R_1$  and  $R_3$  until the capacitor is charged to the voltage across  $R_1$ . The steady-state current is set by  $R_1$  alone. Thus, peaking permits fast turn-on as well as low steady-state current. Table 1 shows the typical turn-on times obtained with different values of resistor  $R_3$ .

Turn-on of the output requires charging the gate capacitors of the output power MOSFETs. This charge is the time-integrated photocurrent from the photodiode array and, in turn, requires a certain amount of current that must pass through the LED. This LED current corresponds to a specific amount of charge which is set by the value of the peaking capacitor and the voltage across  $R_1$ . For this reason, it is not necessary to change the value of the capacitor when other values of peak current are desired; it is necessary only to change the value of

$R_3$  and make sure that the logic output is capable of sinking the higher current.

An alternate peaking circuit for the HSSR-7110 is shown in Figure 9. When the input voltage,  $V_{\text{IN}}$ , goes "low", the pnp transistor turns on for a moment and a pulse of surge current flows through both  $R_S$  and  $R_P$ . When the voltage at node A drops to the input low threshold voltage of the 5400, the transistor turns off, and the steady-state current through the input LED of the SSR is controlled by  $R_S$  alone. The advantage of the peaking circuit shown in Figure 9 over the one shown in Figure 8 is that the SSR can be switched on and off at a higher frequency. For example, with the simple circuit shown in Figure 8, the frequency of a 10-ms input pulse is limited to about 20 Hz. Above 20 Hz, the turn-on time of the SSR starts to increase because the capacitor C does not have enough time to fully discharge, which means that the circuit does not experience the full peaking effect. With the peaking circuit shown in Figure 9, the maximum frequency is limited only by the absolute maximum rating for the pulse width/duty cycle of  $I_F$ .

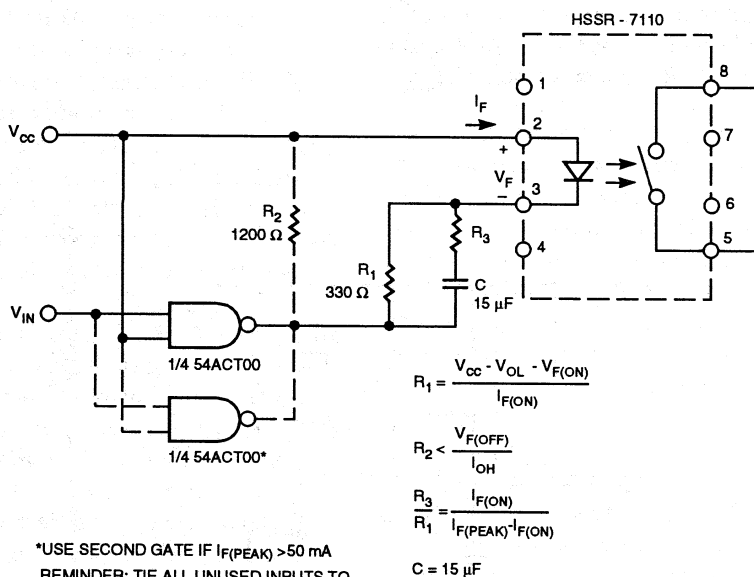

\*USE SECOND GATE IF  $I_{\text{F(PEAK)}} > 50 \text{ mA}$   
REMINDER: TIE ALL UNUSED INPUTS TO GROUND OR  $V_{\text{CC}}$ .

Figure 8. Peaking to Shorten Turn-on Time.

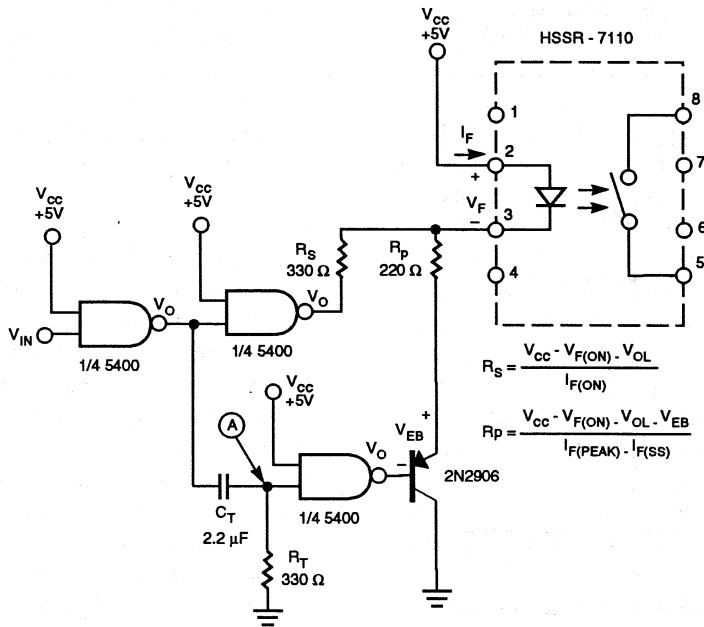

Figure 9. Alternate Peak Circuit.

For applications that are sensitive to variation in the turn-on time, the designer should refer to the data shown in Figures 10 and 11. These figures show that although there is little variation in  $t_{ON}$  within most of the population, a portion of the distribution will vary with use. The optional peaking circuits shown in Figures 8 and 9 can be used to reduce the total turn-on time and, consequently, any associated variation. The drift in turn-on time illustrated in Figure 10 corresponds to the LED's light output power (LOP) degradation with time. This LOP degradation is a function of temperature, time, and input forward current. In general, LOP degradation occurs up to about 1000 hours, at which point the degradation stabilizes.

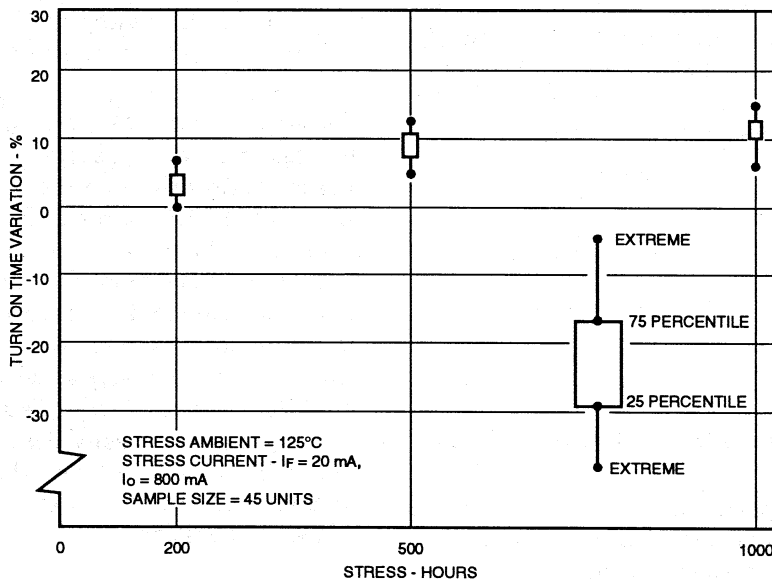
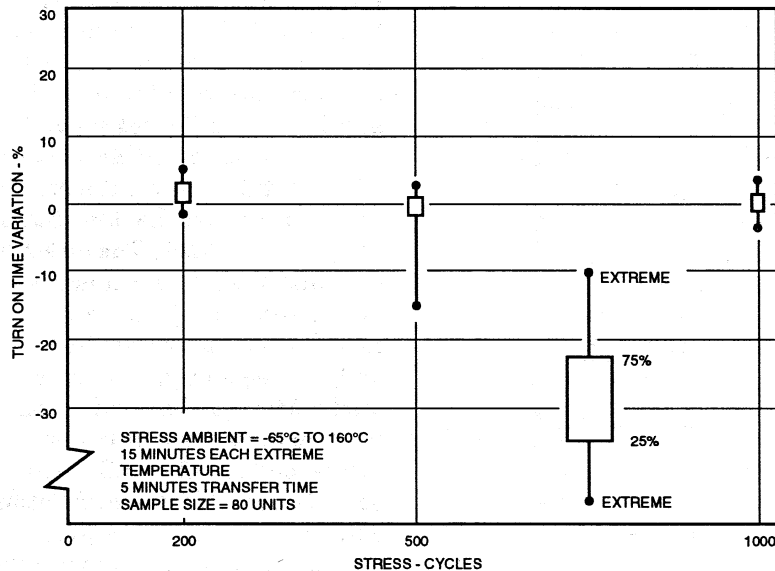

Figure 10. HSSR-7110 Turn On Time Variation with High Temperature Operating Life.

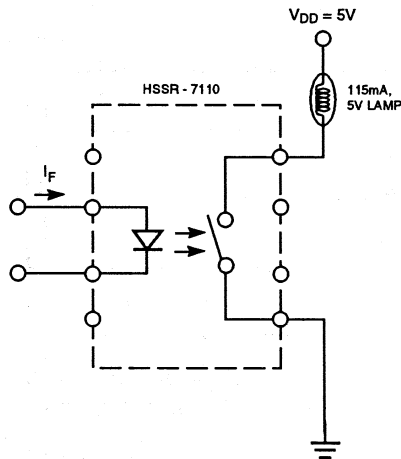

**Figure 11. HSSR-7110 Turn On Time Variation with High Temperature Cycling.**

### SSR Loads

In aircraft applications, SSRs may control lamps for cabin lighting, instrumentation lighting, and status indicators. Upon turn-on, the current through a lamp is very high initially because of the Tungsten filament's low resistance at room temperature. One advantage of the SSR is that it can withstand a fairly large amount of surge current through its output contact. With connection A, the HSSR-7110 has a maximum single-shot output current rating of 5.0 A for a 10-ms pulse. If a designer prefers to actually limit the surge current to increase the lamp filament life, the SSR can be operated with a lower input forward current,  $I_F$ . Although the minimum recommended  $I_F$  is 5 mA, a typical HSSR-7110 can operate with as little as 1 mA. A lower  $I_F$  value will lengthen the turn-on time of the SSR, thus reducing the inrush current. For the 5 V, 115 mA lamp load shown in Figure 12, a decrease in  $I_F$  from 10 mA to 1 mA increased the turn-on time from

0.69 ms to 16 ms and reduced the lamp's inrush current from 6 times to 3 times the steady-state value.



**Figure 12. SSR-7110 with a Lamp Load.**

Operation of the SSR at lower  $I_F$  values, such as 1 mA, will increase the value of  $R_{(on)}$  slightly. For this reason, the maximum steady-state output current rating decreases to ensure that each junction temperature remains below 150°C. With connection A, the maximum steady-state output current is about 220 mA for  $I_F = 1$  mA and

$T_A = -55^\circ\text{C}$  to  $125^\circ\text{C}$ . If the SSR will be operated only up to  $85^\circ\text{C}$ , the maximum steady-state output current is approximately 400 mA. The maximum steady-state output current ratings with connection B are twice the current ratings for connection A.

Similar to a lamp load, a capacitive load will cause a surge current to flow through the output MOSFETs of the SSR, upon initial turn-on. This surge current will depend on the load capacitor value and the rate of rise of the load voltage. In addition, the frequency at which the SSR is switched will affect the output power dissipation. Ten HSSR-7110s were tested at room temperature under the following conditions:

Input current,  $I_F = 20$  mA (1 Hz)  
Load,  $C = 50$   $\mu\text{F}$  capacitor  
Load voltage,  $V = 100$  V  
Number of cycles = 1,000,000

The load capacitor was charged by the load voltage through a 200-ohm resistor. The output of

the SSR-under-test was placed in parallel with the capacitor to discharge it. After one million switching operations, there were no catastrophic failures or parameter drifts.

In order to control greater load current, the HSSR-7110 may be used to drive the input coil of an electromechanical relay (see Figure 13). When SSRs drive inductive loads, very high peak voltages can occur across the output when switching off the loads. The MOSFETs in the output of the HSSR-7110 are able to withstand a reasonable amount of inductive overload. For example, ten units of the HSSR-7110 were tested at room temperature under the following conditions:

Input current = 20 mA (1 Hz)  
 Load, L = 1-H inductor  
 Load voltage, V = 100 V  
 Load current = 500 mA  
 Number of cycles = 1,000,000

After one million switching operations, there were no catastrophic failures or parameter

drifts. No overvoltage protection for the SSR was used in this experiment. However, overvoltage protection is recommended whenever the chance exists for an event where both the withstand voltage rating and the output power dissipation or surge rating are exceeded, or where the energy content of the transient is very large as in lightning-induced events.

As shown in Figure 13, with EMR loads, use of a diode (D1) across the input coil is a common way to protect the SSR's contact. However, if the energy stored in the coil of the EMR during turn-on is of such a magnitude that the inverse diode D1 results in slow turn-off, a zener diode may be used in series with D1.

Metal oxide varistors (MOVs) or TransZorbs™ can also be used for overvoltage protection of the contacts of the SSR. The use of these devices with SSRs is described in both AN 1036 and AN 1046. AN 1046 also explains how to determine the maximum

signal frequency of the HSSR-7110 in an ac-signal application. As an experiment, five HSSR-7110s were configured as simple series switches and tested at room temperature for maximum signal frequency. Each SSR was tested with a load resistor,  $R_L=100$  ohms and an output sine wave,  $V_O=1$  V<sub>p-p</sub>. The maximum signal frequency for  $V_O$  of each SSR to obtain a signal attenuation of -40 dB was approximately 25 kHz.

## Conclusion

The HSSR-7110 family of hermetic power MOSFET optocouplers operate essentially like solid-state relays that can switch both ac and dc signals. They are specified over the full military temperature range, -55°C to 125°C, and are useful in applications that require large output current capability and low on-resistance.

™MOV is a registered trademark of GE/RCA Solid State.

TransZorb is a registered trademark of General Semiconductors.

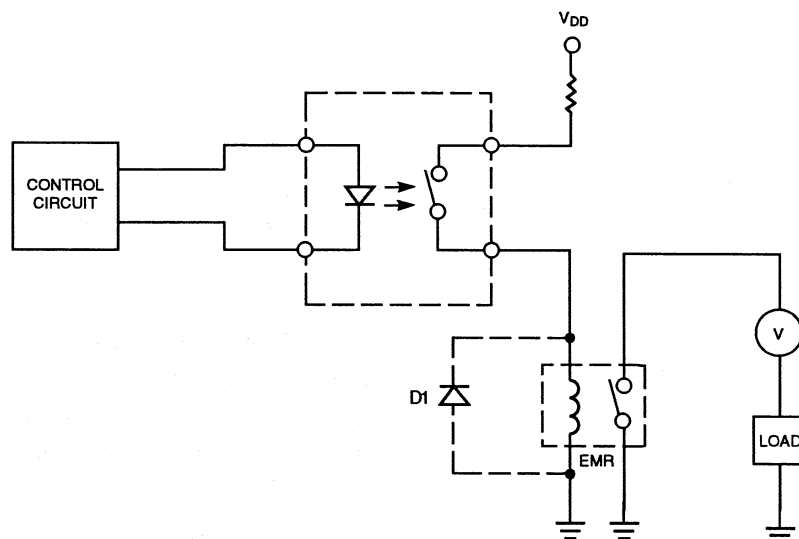

Figure 13. EMR Load for Larger  $I_o$  Applications.

**For more information call:**

**United States: 1-800-752-0900\***

**Canada: (416) 678-9430\***

**Europe: (49) 7031/14-0\***

**Asia Pacific/Australia: (65) 290-6360\***

**Japan: (813) 3331-6111\***

**\* Or call your local HP sales office listed  
in your telephone directory. Ask for a  
Components representative.**

**Data Subject to Change**

**Copyright © 1992 Hewlett-Packard Co.**

**Printed in U.S.A. 5091-4502E (5/92)**