



HEWLETT-PACKARD MODEL 430C
MICROWAVE POWER METER ACCURACY

B. P. Hand and T. A. Christiansen
Hewlett-Packard Company
Palo Alto, California

I. Introduction

We are frequently asked how we can be sure our 430C Microwave Power Meter measures power accurately, and further, if there is any convenient method available to field check its accuracy. This memorandum has been written in response to these questions and shows why we believe the hp 430C Microwave Power Meters have better than $\pm 5\%$ accuracy. In the following pages the hp 430C will be briefly described, the factory test procedure detailed, and a method of field checking accuracy suggested. In addition, consideration will be given to bolometer mount efficiency, and a reasonably accurate estimate of overall power measuring system accuracy will be presented.

II. Power Meter Theory

One of the most universally used methods of measuring microwave power is by means of a bolometer element which changes r-f energy into heat energy and, in turn, changes resistance in proportion to the heat applied.

This change in resistance can be measured and used to determine the amount of r-f energy. However, this method is accurate over only small variations in power, since bolometer elements have non-linear characteristics in that the slope of resistance vs. power is not constant. Thus, power measurements made by a system based on a simple measurement of change in resistance would be quite slow and would require extensive correction tables or charts.

This difficulty may be avoided by bringing the bolometer element up to a predetermined operating resistance with dc and/or af power before any rf power is applied. As the rf power is applied, the dc and/or af power is reduced to maintain the same bolometer operating resistance. Thus, the bolometer element is used only to indicate specific reference levels and therefore bolometer non-linearity is of no concern. In this method, the rf power is equal to the amount of dc or af power removed, which can be easily determined by conventional measuring instruments. This method is capable of great accuracy and is essentially the system used in the hp 430C power meter.

III. hp 430C Description and Operation

In the hp 430C (Block Diagram, Figure 1), the bolometer element is brought up to a predetermined operating resistance in the absence of rf power by the application of both dc and audio frequency power. The 430C circuit is so arranged that audio power is automatically removed as rf power is applied. The amount of af power removed is displayed by an accurate vacuum tube voltmeter, calibrated to show a decrease in audio power as an increase in rf power.

The heart of the hp 430C is a self-balancing audio bridge in which the bolometer element functions as one arm. Bridge resistors are selected and arranged so that the bridge will be balanced * when the bolometer element is brought up to a predetermined operating resistance. This is accomplished by supplying the bolometer with dc power from a stable internal source, and 10.8 KC af power from an internal RC oscillator. Thus, if in the absence of rf power, 15 mw is required to bring a bolometer element up to operating resistance, 5 mw would be supplied automatically by the af source if 10 mw were supplied by the dc supply; 10 mw would be supplied automatically if the dc supply furnished only 5 mw, etc.

In theory, an infinite number of af-dc power combinations might be used to bring the bolometer element up to operating resistance. In practice, the number is limited by the requirements imposed by the vacuum tube voltmeter used to read the audio frequency power removed when rf power is applied. This vacuum tube voltmeter, which incorporates a substantial amount of negative feedback to minimize the effect of non-linear crystal resistance in the meter circuit, is arranged to zero on a specific level of af power. For example, on a 10 mw range, the meter zeros on 12 mw of audio power and reads full scale (+10 mw rf), with 2 mw of audio power. Thus, again referring to our 15 mw bolometer example, only 3 mw would be supplied by the dc source. However, on the lower rf power ranges, the amount of audio power required to zero and to give full scale readings de-

* In this bridge, as in all so-called self-balancing bridges, actual balance never occurs, since a small unbalance is necessary to provide oscillator feedback.



creases, and therefore dc power requirements increase. In the previous example, on the 1 mw range 1.2 mw would be supplied by the audio source and 13.8 mw by the dc supply; and on the .1 mw range, .12 mw audio and 14.88 mw dc would be required. Under such conditions, it is easy to see the necessity for exceptional dc stability on the lower rf power ranges.

It might appear that the absolute accuracy of the hp 430C would be difficult to determine since we have no convenient absolute standard of rf power available at the present time. However, from the foregoing, it can be seen that if we assume heating effect of rf power is the same as that of other types of power, hp 430C accuracy can be checked against readily available absolute standards of voltage, current and resistance. This is essentially how the hp 430C is tested in the factory.

IV. hp 430C Factory Test Procedure

After an hp 430C has been assembled, the general procedure is to carefully calibrate the voltmeter section and adjust the bridge network operating resistors as accurately as possible. Overall power checks are then made on a run of instruments to make sure that the maximum deviation between power readings is no more than $\pm 3\%$. To prevent possible increase in error from run to run, a 430C power meter is periodically selected at random and checked against a simple dc substitution bridge; results must agree within $\pm 5\%$, and generally are within $\pm 3\%$.

A detailed description of the factory test procedure will show the magnitude of the possible manufacturing errors.

First, the hp 430C voltmeter section is calibrated against a very accurately calibrated hp 400H Vacuum Tube Voltmeter as outlined in the hp 430C Instruction Manual. Here the possible errors are those of the hp 400H (not more than $\pm 1\%$) and the hp 430C range switch resistors (not more than $\pm 1/4\%$).

Next, the bridge is adjusted to give a previously determined bolometer element operating resistance. The accuracy of these adjustments is based on the accuracy of the 200 ohm resistances in the upper arm of the bridge. These are specially wound to within $\pm 1/4\%$ of their specified value. The other arms of the bridge are adjusted to give a 3 to 1 voltage division on the bolometer side. To avoid complications in circuit switching, only a single fixed setting of the adjustable bridge resistor is used. Therefore, a compromise is generally necessary in obtaining the 3:1 voltage division among the various combinations of bolometer element temperature coefficients and operating resistances. However, the

voltage division is usually exactly 3 to 1 for one combination and within 1% of this 3 to 1 ratio for the others -- well within the 2% test specification. Measurements are made on a recently calibrated hp 400H Vacuum Tube Voltmeter at actual voltages of 1 and 3 volts. This increases accuracy because the readings are taken on the same half of the hp 400H attenuator (it splits between the 0.3 and the 1 volt ranges), and on the same part of the meter face. Thus, possible tracking errors are eliminated and the resultant accuracy is about that of the hp 400H range switch resistors -- $\pm 0.2\%$.

After the voltmeter is calibrated and the bolometer bridge resistors adjusted, all instruments on a production run are lined up in a row and checked against a stable but arbitrary amount of power, usually about .95 milliwatts from a signal generator. To guard against troubles common to the whole production run, an instrument from a previous run is included. Power checks are made with an hp 475B Tunable Bolometer Mount with a barretter and a thermistor for all possible combinations, e. g. , positive temperature coefficient 200 ohm elements and negative 100 and 200 ohm elements. Readings are compared and must be within $\pm 3\%$. Ordinarily, there will be no more than one or two out of 50 instruments that deviate more than 2% from the average.

On the basis of the care taken in construction and in testing, we feel the overall accuracy of any hp 430C Microwave Power Meter is within $\pm 3\%$ of full scale when it leaves the factory. However, to insure an adequate safety factor, our commercial specifications state a $\pm 5\%$ accuracy.

V. Field Checking hp 430C Accuracy

We believe the best and easiest way to field check an hp 430C power meter is to check and calibrate the voltmeter and check the bolometer operating resistance. The procedure for making these checks is detailed in the instruction manual, and properly done, should result in an instrument which fully meets factory specifications.

However, sometimes it is desirable to have an alternate method of checking accuracy available. For such situations, we believe the substitution bridge method is the most practical and most complete method available. This is the method used at the factory to periodically check the accuracy of hp 430C Microwave Power Meters.

The equipment is arranged as shown in Figure 2. The bridge consists of three accurately wound 200 ohm resistors and a bolometer element and mount. For convenience, Figure 2 shows a 50 ohm coaxial mount in which two thermistors are connected in

parallel to appear as 50 ohms to rf and in series to appear as 200 ohms to af and dc. Bridge balance is indicated by a sensitive galvanometer. Dc bias is provided by a battery source of ample capacity and 10 KC audio by a stable, well regulated audio oscillator -- an ϕ 200CD or equivalent. Rf power is supplied by a stable, well regulated rf source. The bridge is balanced with audio and dc in the absence of rf signal. The audio voltage appearing across the thermistors is measured with a very accurately calibrated vacuum tube voltmeter -- an ϕ 400D or equivalent -- and the audio power computed:

$$\text{Audio Power} = \frac{(\text{Audio Voltage})^2}{\text{Thermistor Resistance}} = \frac{(V_{af})^2}{200}$$

The audio voltage is removed and the rf power applied to the thermistor mount. Rf output is adjusted until the bridge is re-balanced. In this condition, the rf power absorbed in the element is equal to the audio power computed above.

The rf source is then turned off and the thermistor mount removed from the substitution bridge and connected to the ϕ 430C power meter, whose tubes, voltmeter section, etc., have been previously checked as outlined in the instruction manual. The meter is zeroed and, without changing its level, the rf power is applied to the thermistor mount. The rf power level is read on the ϕ 430C and compared with the rf power previously computed.

This method will give excellent results. However, it should be pointed out that a large number of variables are present, and unless extreme care is taken, the rf power computed by the substitution bridge method is likely to be less accurate than that provided by the ϕ 430C. This is because the ϕ 430C is itself a precision bridge equipped with an extremely stable oscillator and a well regulated power supply.

Some specific sources of error in the substitution bridge method are:

- 1) Variation in rf power due to instability in the rf source.
- 2) Variation in dc bias due to weak battery supply.
- 3) Inaccuracies in the bridge resistors.
- 4) Calibration errors in the vacuum tube voltmeter used to read af voltage.
- 5) Inaccuracies in reading the vacuum tube voltmeter scale -- especially troublesome on the lower ranges and on lower portions of the scale.

6) Undesired temperature changes due to:

- a. Variations in ambient temperature levels when appreciable time elapses between zero setting the power meter and reading the power.
- b. Spurious heating effects of stray fields.

VI. Bolometer Element and Mount Efficiency

Up to this point, we have not been concerned with the power absorption portion of the measuring system -- the bolometer element and the bolometer mount. However, the efficiency of these two items should be discussed, since they have a direct bearing on the accuracy of the power measuring system.

Bolometer elements used for microwave measurements are of two general types -- barretters and instrument fuses in which the temperature coefficient of resistance is positive, and thermistors in which it is negative. The bolometer element must be mounted and well matched to the microwave transmission system undergoing measurement. Thus, the efficiency of the absorption system depends primarily on the bolometer element and on the design and construction of the bolometer mount. Some specific considerations effecting this efficiency are: (1) the equivalent of dc, af and rf heating effects, which is doubtful above 10 KMC, (2) heat absorption in the walls of the mount, and (3) losses due to impedance mismatches incurred in the placement of the mount in the system to be measured. Although losses from any of these sources can be severe, good design and careful construction will minimize their effect. For example, as a result of experimental work, Hewlett-Packard fixed tuned mounts are reliably estimated to be from 95 to 98% efficient, Hewlett-Packard tunable mounts somewhat less efficient due to loss in finger contacts, higher SWR, etc.

VII. Overall Power Meter Measuring System Accuracy

Although power meter accuracy and bolometer mount efficiency may be of interest by themselves, their contribution to overall power measuring system accuracy is generally of major importance. It is difficult to give any specific figures for overall system accuracy since a large number of external variables must be considered in any application. Most obvious perhaps, is the physical condition of the 430C and the bolometer element and mount. Less obvious is the manner in which the measurements are made; for example, substantial errors can be caused by varia-

tions in ambient temperature levels when appreciable time elapses between zero setting the power meter and reading the power.

However, experimental results show a probable overall measuring system accuracy of better than $\pm 10\%$ can be achieved if measurements are carefully and correctly made under proper operating conditions, and if allowance is made for bolometer mount efficiency.

Specific accuracies can be estimated for individual situations. For example, suppose we desire an estimate of total accuracy in a 4,000 megacycle,

10 mw, CW system in which the source and line are perfectly matched at 50 ohms. In this case, if we use the hp 430C Microwave Power Meter and an hp 477B Coaxial Thermistor Mount, we must take into account the following factors: the loss of the hp 477B mount which is reliably estimated to be $-3-1/2 \pm 1-1/2\%$ -- simply another way of stating the previously expressed 95 to 98% efficiency figures; the 1.3 maximum standing wave ratio due to hp 477A -- line mismatch which introduces an additional -2% loss; and the commercially specified $\pm 5\%$ accuracy of the hp 430C. Combining these terms, the maximum estimated error of the hp 430C reading is $-5-1/2\% \pm 6-1/2\%$.

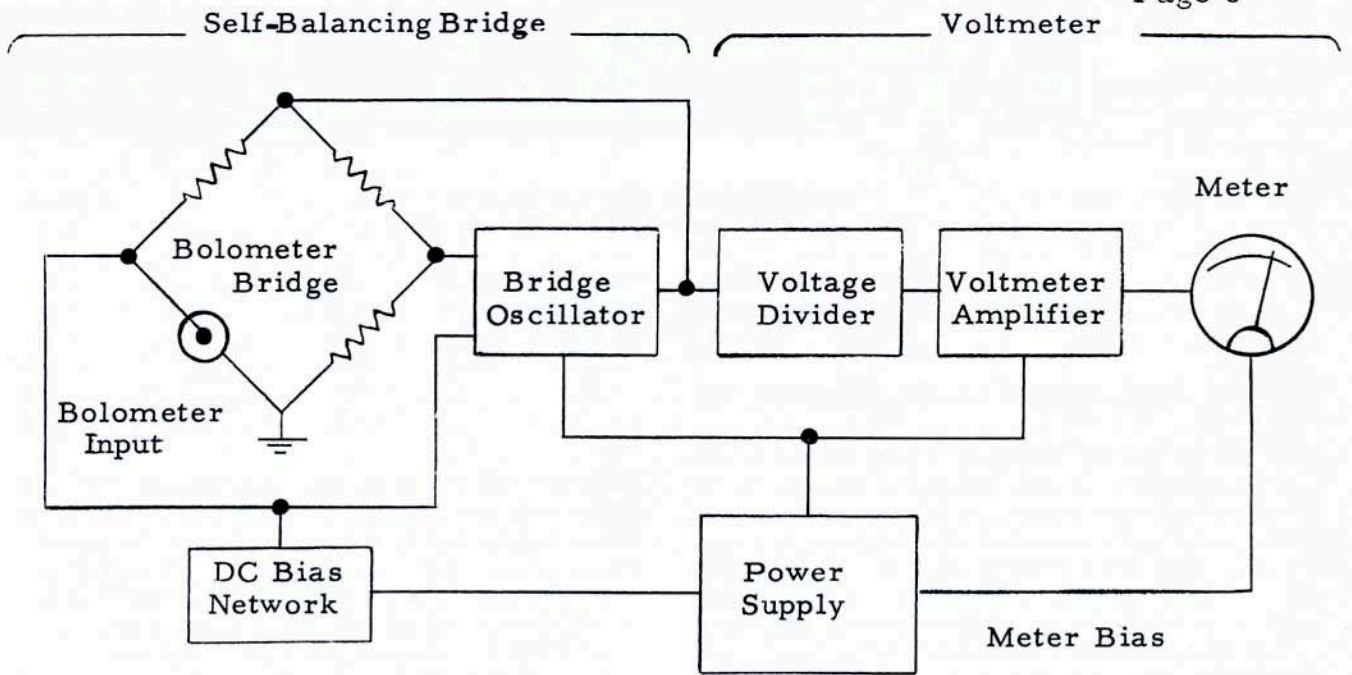

BLOCK DIAGRAM  MICROWAVE POWER METER, MODEL 430

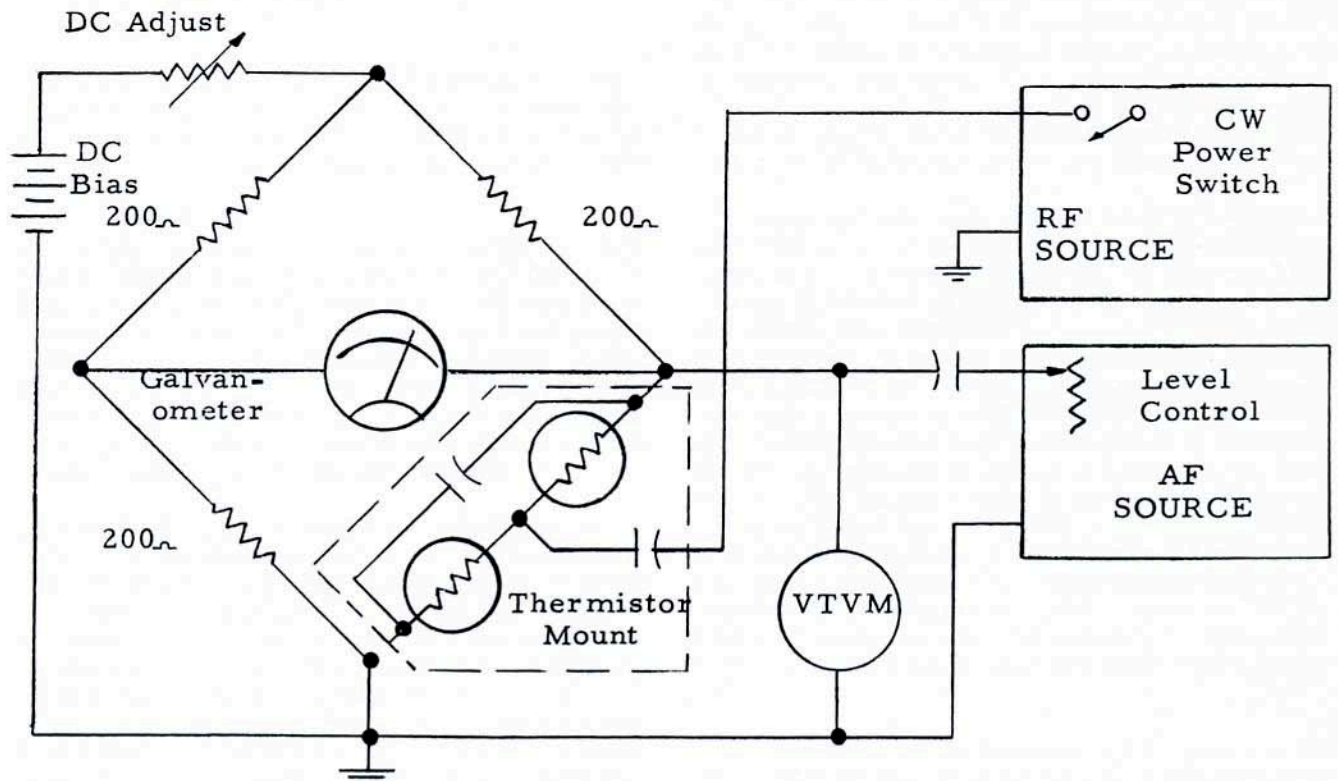

SUBSTITUTION BRIDGE USED IN FIELD CHECKING  430C POWER METER ACCURACY