

The following is a reprint of the Harrison Labs' application manual. The last pages of this sales amplifier list the Power Supplies recommended for customers with 50 Hz line frequency. The Power Supplies shown on this page are manufactured in Europe.



**721 A**  
0-30 V, 0-150 mA



**6960 A**  
0-18 V, 0-600 mA  
0-36 V, 0-300 mA



**6961 A**  
0-20 V, 0-1.5 A  
0-40 V, 0-0.75 A



**6962 A**  
0-20 V, 0-1.5 A



**6963 A**  
0-40 V, 0-0.075 A

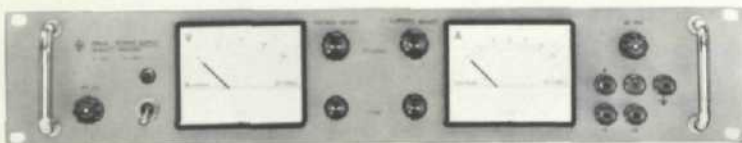

**6964 A**  
0-18 V, 0-10 A

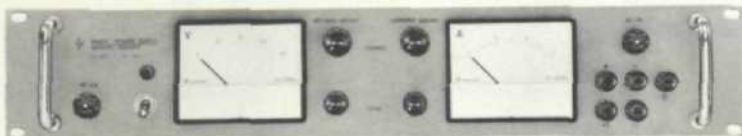

**6965 A**  
0-36 V, 0-5 A

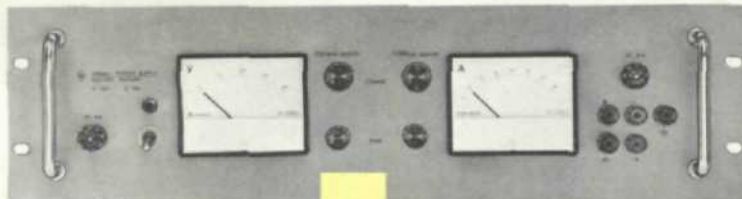

**6966 A**  
0-36 V, 0-10 A

# POWER SUPPLY APPLICATION MANUAL

<b>A. H-LAB POWER SUPPLY CIRCUIT PRINCIPLES</b>	
A1. Introduction	3
A2. Constant Voltage Power Supply	3
A3. The Regulated DC Power Supply—An Operational Amplifier	4
A4. Reference Circuitry	4
A5. Comparison Amplifier Circuitry	5
A6. Zero Output Impedance	5
A7. Constant Current Power Supply	6
A8. Constant Voltage/Constant Current (CV/CC) Power Supplies	6
A9. Constant Voltage/Current Limiting (CV/CL) Power Supplies	7
A10. Series Regulator Circuitry	8
A11. Variable Transformer Preregulator	8
A12. SCR (Silicon Controlled Rectifier) Preregulator	9
A13. SCR Regulated Power Supplies	9
A14. "Piggy-Back" Regulator	10
<b>B. OPERATIONAL FEATURES AND OPTIONS</b>	
B1. No Overshoot on Turn-On, Turn-Off, or AC Power Removal	11
B2. Protection Circuits	11
a. Short Circuit Protection	11
b. Constant Current Overvoltage Protection	11
c. Reverse Voltage Protection	11
d. SCR Voltage Protection	11
e. External Overvoltage Protection—"Crowbars"	12
B3. Remote Error Sensing	12
B4. Automatic Error Sensing	13
B5. Remote Programming with Resistance Control	13
B6. Remote Programming with Voltage Control	15
B7. Remote Programming Accuracy	15
B8. Speed of Remote Programming	16
B9. Parallel Operation	17
B10. Auto-Parallel Operation	17
B11. Series Operation	17
B12. Auto-Series Operation	18
B13. Auto-Tracking Operation	18
B14. Grounded and Floating Operation	19
B15. Adjustable Transient Recovery	19
B16. Adjustable Meters	20
B17. Improved Stability with Chopper Stabilization	20
<b>C. SPECIAL APPLICATION PROBLEMS</b>	
C1. DC Power Distribution and Multiple Loading	22
C2. Dual Output Using Resistive Divider	22
C3. Duty Cycle Loading	22
C4. Reverse Current Loading	24
C5. Converting a Constant Voltage Supply to Constant Current Output	24
C6. Automatic Battery Charging	25
C7. Operation at Elevated Temperatures	25
<b>D. POWER SUPPLY SPECIFICATIONS—DEFINITION AND MEASUREMENT</b>	
D1. Constant Voltage Power Supply Measurements	26
a. Test Set-Up—General Comments	26
b. Line Regulation	27
c. Load Regulation	28
d. Ripple and Noise	28
e. Transient Recovery Time	29
f. Stability	30
g. Temperature Coefficient	31
h. Other Constant Voltage Specifications	31
D2. Constant Current Power Supply Measurements	31
a. Test Set-Up—General Comments	31
b. Line Regulation	32
c. Load Regulation	32
d. Ripple and Noise	32
e. Stability	33
f. Temperature Coefficient	33
g. Other Constant Current Specifications	33
H-LAB TECH LETTERS	33



# A. H-LAB POWER SUPPLY CIRCUIT PRINCIPLES

## A1. INTRODUCTION

Since its inception nearly ten years ago Harrison Laboratories has been a leader in the design of versatile, high performance, regulated DC power supplies so necessary for the proper performance of most of today's complex load devices. A single H-Lab DC regulated power supply employs engineering techniques drawn from the latest advances in many disciplines—low-level, low-noise amplification, high power, wide-band amplifying techniques, operational amplifier and feedback principles, pulse circuit techniques, and the newest developments in semiconductor devices.

The full benefits of the engineering which has gone into a modern DC regulated power supply cannot be realized unless the user (1) recognizes the inherent versatility and high performance capabilities, and (2) understands how to apply these features. These are the two objectives of this Application Manual, which includes an extensive coverage of power supply circuitry, features, specifications, measurement methods, and application tips.

Electronic power supplies can be defined as circuits which transform electrical input power—either AC or DC—into output power—either AC or DC. This definition thus excludes power supplies based on rotating machine principles and distinguishes power supplies from the more general category of electrical power sources which derive electrical power from other energy forms (e.g. batteries, solar cells).

Electronic power supplies may be subdivided into four classifications:

- (1) AC in, AC out—line regulators and variable frequency supplies.
- (2) DC in, DC out—converters
- (3) DC in, AC out—inverters
- (4) AC in, DC out

This last subcategory is by far the most common of the four and is generally the one referred to when speaking of a "power supply". All of the topics of this Application Manual relate to AC Input, DC Output power supplies.

Simple rectifying circuits alone are not adequate to provide a ripple-free DC whose value remains constant in spite of changes in input line voltage, load resistance, and ambient temperature; most practical applications require a *regulated* power supply which interposes a control element either in shunt with or in series between the rectifier and the load device. The shunt regulator, which must withstand the full output voltage under normal operating conditions and is less efficient for most

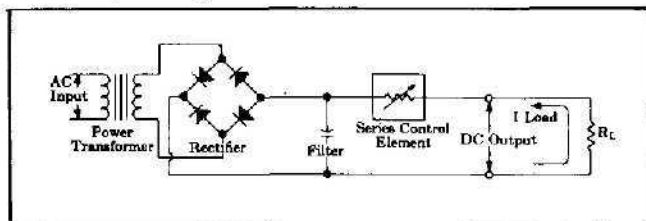

FIGURE 1. Series Regulator Circuit

applications, is less often used than the series regulator.

## A2. CONSTANT VOLTAGE POWER SUPPLY

An ideal constant voltage power supply would have a zero output impedance at all frequencies. Thus, as shown in Figure 2, the voltage would remain perfectly constant in spite of any changes in output current demanded by the load.

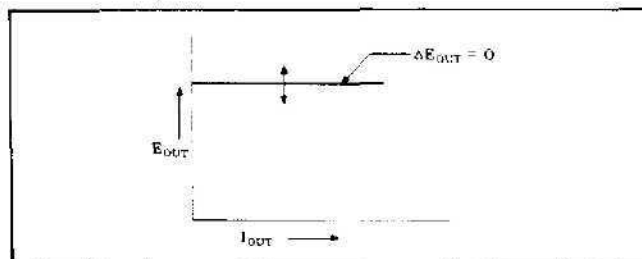

FIGURE 2. Ideal constant voltage power supply output characteristic.

Figure 3 shows the basic feedback circuit principle used in all H-Lab constant voltage power supplies. The AC input, after passing through a power transformer, is rectified and filtered. The series regulator, by feedback action, alters its voltage drop so as to keep the regulated DC output voltage constant in spite of changes in the unregulated DC and other disturbances.

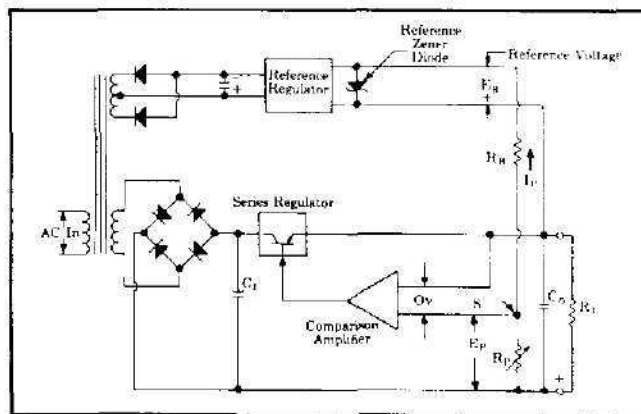

FIGURE 3. Constant voltage regulated DC power supply.

The comparison amplifier continuously monitors the difference between the voltage across the front panel voltage control  $R_P$  and the output voltage. If these voltages are not equal, the amplified error output of the comparison amplifier is of such a magnitude and polarity as to change the conduction of the series regulator, thereby changing the current through the load resistor until the output voltage equals the voltage  $E_P$  across the voltage control.

Since the net difference between the two voltage inputs to the comparison amplifier is kept at zero by feedback action, the voltage across the resistor  $R_R$  is also held equal to the reference voltage  $E_R$ . Thus the current  $I_P$  flowing through  $R_R$  is constant and equal to  $\frac{E_R}{R_R}$ . The input impedance of the comparison amplifier is very

high, and essentially all of the current  $I_P$  flowing through  $R_R$  also flows through  $R_P$ . Because this programming current  $I_P$  is constant,  $E_P$  (and hence the output voltage) is variable and directly proportional to  $R_P$ . Thus the output voltage becomes zero if  $R_P$  is reduced to zero ohms.

### A3. THE REGULATED DC POWER SUPPLY—AN OPERATIONAL AMPLIFIER

An operational amplifier is a particular type of voltage feedback amplifier having its feedback path connected as shown in Figure 4.\* With large values of  $A$ , the "summing point"  $S$  is essentially at zero potential or "virtual ground", and the output signal  $E_{OUT} = -\frac{R_F}{R_I} E_{IN}$

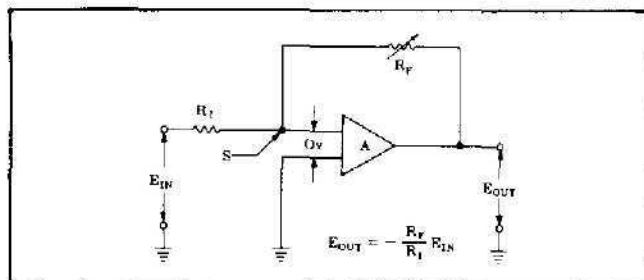

FIGURE 4. An operational amplifier

Figure 5 shows the same operational amplifier utilizing as its input signal the DC voltage developed across a reference diode. An output capacitor and load resistor have also been added. The topology of Figure 5 is identical to Figure 3, except that in Figure 5 the series regulator has been included as the last stage inside the amplifier block, and the  $B+$  source and auxiliary rectifiers have not been shown explicitly. A constant voltage power supply, therefore, can be thought of as a particular type of operational amplifier.

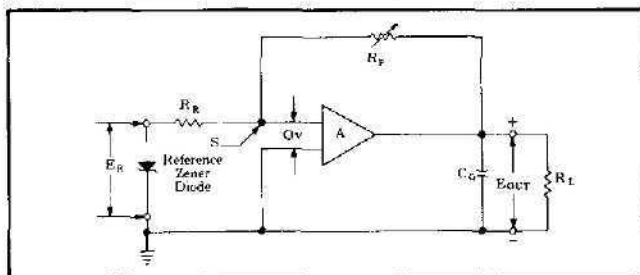

FIGURE 5. Operational amplifier representation of a constant voltage power supply.

The following chart gives examples of the correspondence between power supply and operational amplifier terminology:

GENERAL CATEGORY	SPECIFIC EXAMPLE
Operational Amplifier	Constant Voltage Power Supply
$B+$ Source	Rectifier
Amplifier	Regulator
Input Signal	DC Reference
Output Signal	Regulated DC

\*An introduction to the operational amplifier concept can be found in Millman, J., and H. Taub: "Pulse and Digital Circuits," chap. 1, McGraw-Hill Book Company, Inc., New York, 1956.

Thus, the function of a regulator in a constant voltage DC power supply is to reproduce the reference input as accurately as possible, with a voltage gain of  $\frac{R_P}{R_R}$ . On a percentage basis the power supply performance (temperature coefficient, stability, line regulation, ripple, etc.) can be no better than the performance of its reference supply.

Restrictions are generally added to the design of a regulated power supply which limit its performance as compared with the more general case of the operational amplifier. Among the more important of these are:

1. The power supply is heavily loaded with an output capacitance  $C_O$  in order to insure feedback loop stability for any phase angle load.
2. The power supply can conduct current in one direction only, whereas an operational amplifier will in most cases be capable of an AC output.
3. The output of a DC power supply is usually current limited. While there is a maximum current which can be obtained from any amplifier, a current limited or Constant Voltage/Constant Current regulated power supply differs in that there is a very sharp limit to the maximum output current.

The answers to many application problems and questions involving power supply performance can be obtained from a simple block diagram consideration of a power supply as an operational amplifier which is capacitively loaded, current limited, and has a unidirectional DC output.

### A4. REFERENCE CIRCUITRY

In all H-Lab power supplies the reference voltage is developed across a reference zener diode having a low temperature coefficient and a low incremental resistance. This reference zener diode is in turn fed from a reference regulator—actually a low power, closed loop auxiliary supply designed to keep the operating current through the reference zener diode constant, thereby assuring reference voltage immunity against line voltage changes and other disturbances.

Rather than to develop simply one output voltage, a reference circuit is generally used in H-Lab power supplies to develop several voltage levels from one auxiliary supply for use at various points throughout the regulator circuitry.

Figure 6 is a simplified schematic of a typical reference circuit. Nearly all auxiliaries in H-Lab supplies are referred to the negative output (or negative sensing)

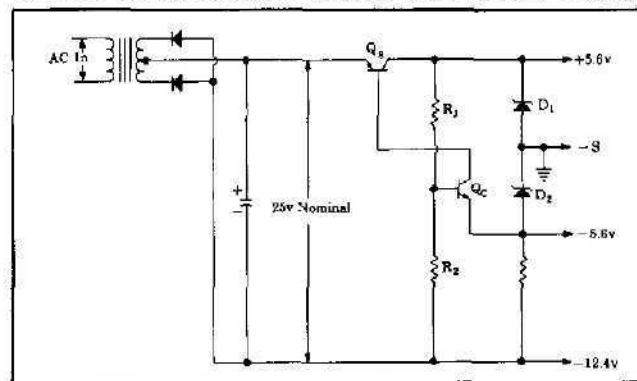

FIGURE 6. A simplified reference circuit

terminal as a circuit common or ground. Consequently, in Figure 6 the terminal of the reference circuit which is connected to negative sensing has been designated with a ground symbol, and most voltages are given with respect to this common reference point.

This reference circuit is actually a small closed loop regulator employing  $Q_3$  as the series regulating element and  $Q_2$  as the comparison amplifier.  $D_1$  and  $D_2$  are low temperature coefficient zener diodes with low incremental resistance; thus the voltage fluctuation across these reference diodes is even less than any small change which may be present across the 18 volt regulated output of this reference auxiliary.

#### A5. COMPARISON AMPLIFIER CIRCUITRY

The comparison amplifier circuitry is second in importance only to the reference circuit in determining the degree of regulation which will be obtained. Because of the need in the input stage for low noise, low drift performance, a differential amplifier is frequently used. A transistor has an emitter-to-base voltage which varies approximately 2 mv per degree Centigrade. Such a voltage variation in the input amplifier stage would be accompanied by an equal change in the power supply output voltage. By using two similar transistors in a differential amplifier configuration and placing them in thermal proximity, this effect is largely cancelled and the drift performance of the supply is markedly improved.

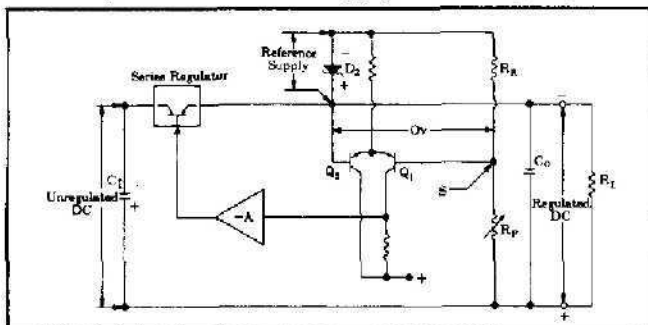

FIGURE 7. Constant voltage regulator showing simplified comparison circuit.

The feedback regulating action characteristic of a constant voltage power supply can be demonstrated by assuming that a disturbing influence has caused a momentary increase in the "Regulated DC" output voltage of Figure 7. If we regard the negative output terminal as "common" or "ground", this output voltage increase is equivalent to the positive output terminal and the summing point "S" becoming more positive. The collector of  $Q_1$  thus goes negative and causes a more positive potential to be impressed on the base of the series regulator transistor, reducing its conduction. The output voltage then decreases back to its normal value and the error voltage between the base of  $Q_1$  and  $Q_2$  is reduced to zero.

Since any change in the resistance value of  $R_R$  or  $R_P$  will cause a change in the output voltage, wire-wound elements having a very low temperature coefficient are used. These resistors are operated at a level which is considerably less than their power rating so that their surface temperature will not be significantly higher than ambient and subject to thermal fluctuations.

Figure 8 shows several refinements which Harrison Laboratories typically includes in its comparison circuit in order to improve performance and reliability. Capacitor  $C_1$  is added to improve the regulator performance with regard to ripple and other AC disturbances. Diodes  $D_3$  and  $D_4$  are added to limit the maximum voltage which can be impressed on the base of  $Q_1$ . Normally there is zero volts across these diodes and they are not conducting; sudden changes in the output voltage caused by shorting the output terminals or rapidly altering the value of  $R_P$  will cause  $D_3$  and  $D_4$  to conduct, thereby preventing the burn-out of transistor  $Q_1$ . Resistor  $R_3$  is added to balance the  $I_{CO}$  effects of the bases of  $Q_1$  and  $Q_2$ , and is nominally equal to the base impedance of  $Q_1$ . Variable resistor  $R_4$  is one way in which positive feedback can be added within the regulator loop; the reason for the addition of this positive feedback is discussed in the next section.

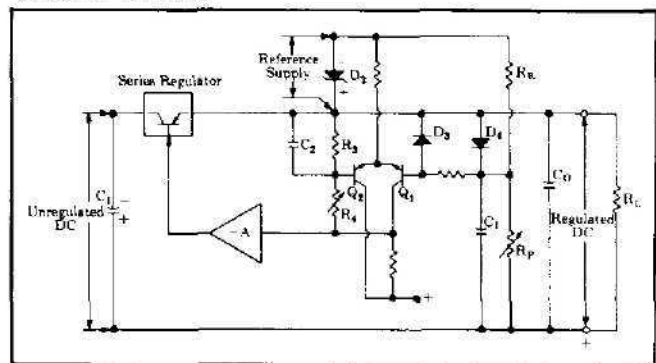

FIGURE 8. Constant voltage regulator with improved comparison circuit.

#### A6. ZERO OUTPUT IMPEDANCE

As mentioned earlier, the ideal constant voltage power supply would have a zero output impedance at all frequencies; this would result in no change in output voltage for a change in output current from no load to full load, and would mean that there could be no mutual coupling effects between load devices connected to the same power supply. It is doubtful that the ideal constant voltage power supply can ever be achieved, but one can be realized which has a zero output impedance at zero frequency (DC) using the circuit shown in Figure 8.

The output impedance of a regulated power supply (or any negative voltage feedback amplifier) is given by

$$Z_{OF} = \frac{Z_O}{1 - \mu\beta} \quad (1)^*$$

where:  $Z_{OF}$  = the output impedance with the feedback loop closed

$Z_O$  = the output impedance which would be present if amplifier stages within the regulator were not activated

$\mu$  = the combined voltage gain of all amplifier stages within the regulator feedback loop

$\beta$  = the feedback factor from the output terminals to the first amplifier stage.

$\mu$  is actually the composite of the several stages of gain within the feedback loop. Therefore,

\*For negative feedback,  $\mu\beta$  is a negative number, and the denominator of (1) is a positive number greater than unity.

$\mu = \mu_1 \mu_2 \mu_3 \dots$ , where the subscripts refer to the first, second, third stage, etc. Consequently, a more exact description of the output impedance of a power supply is

$$Z_{OF} = \frac{Z_O}{1 - \mu_1 \mu_2 \mu_3 \dots \beta} \quad (2)$$

Now let us assume that local positive feedback is added around the first stage. The gain of this stage is therefore

$$\mu_1 = \frac{\mu_1'}{1 - \mu_1' \beta_1} \quad (3)$$

where:  $\mu_1'$  is the gain of the first stage without local positive feedback

$\beta_1$  is the local positive feedback factor for the first stage.

Substituting equation (3) into (2) yields a new expression for the output impedance of the power supply:

$$Z_{OF} = \frac{Z_O}{1 - \frac{\mu_1' \mu_2 \mu_3 \dots \beta}{1 - \mu_1' \beta_1}} \quad (4)$$

It can be seen that if  $\beta_1$ , the local positive feedback factor for the first stage, is adjusted so that  $\mu_1' \beta_1$  exactly equals unity, then the denominator of equation (4) increases without bound and the output impedance  $Z_{OF}$  of the power supply becomes zero!

Figure 8 shows one way of adding positive feedback to a power supply regulator to obtain zero output impedance. Control  $R_4$  furnishes the local positive feedback from the collector of  $Q_1$  to the base of  $Q_2$ . Adjustment of this control enhances the gain of this comparison amplifier and permits the power supply to retain its static output voltage perfectly constant in spite of a no load to full load change in load current.

#### A7. CONSTANT CURRENT POWER SUPPLY

The ideal constant current power supply would exhibit an infinite output impedance (zero output admittance) at all frequencies. Thus, as Figure 9 indicates, the ideal constant current power supply would accommodate a load resistance change by altering its output voltage by just the amount necessary to insure that its output current would remain constant.

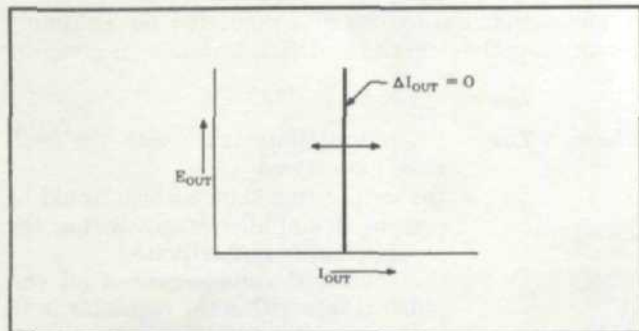

FIGURE 9. Ideal constant current power supply output characteristic.

Constant current power supplies find many applications in semiconductor circuitry, and are also well suited for supplying fixed currents to focus coils or other magnetic circuits, the current remaining constant despite

temperature-induced changes in the resistance of the load. Just as loads for constant voltage power supplies are always connected in parallel (never in series), loads for constant current power supplies must be connected in series (never in parallel).

Figure 10 illustrates the elements which go into a constant current power supply, many of which are identical to the elements found in a constant voltage power supply (Compare with Figure 3). The feedback loop acts continuously to keep the two inputs to the comparison amplifier equal; one of these inputs is the voltage drop across the front panel current control, while the other is the IR drop developed by the load current  $I_L$  flowing through the current monitoring resistor  $R_M$ . If the two inputs to the comparison amplifier are momentarily unequal, then the comparison amplifier output changes the conduction of the series regulator, thereby changing the load current and the voltage drop across the current monitoring resistor, reducing the error voltage at the comparison amplifier input to zero. Increasing the value of the current control  $R_Q$  results in a momentary increase in the negative value presented at the upper input to the comparison amplifier until the regulator action increases the load current by a corresponding amount so that the error voltage is reduced to zero.

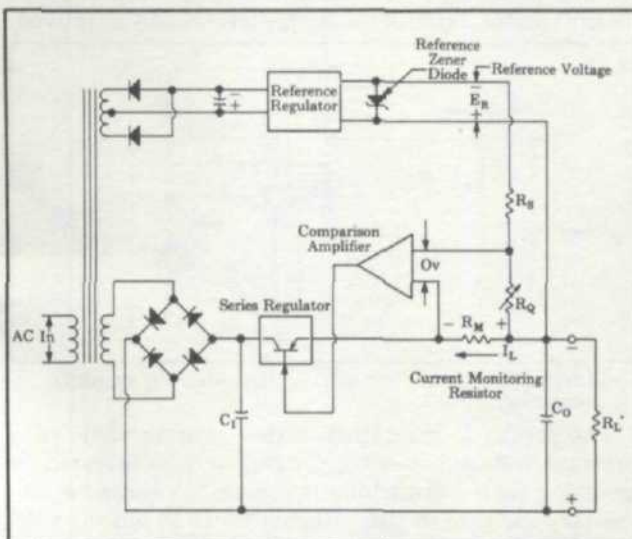

FIGURE 10. Constant current regulated DC power supply.

#### A8. CONSTANT VOLTAGE/CONSTANT CURRENT (CV/CC) POWER SUPPLIES

The fact that so many elements are common to the block diagram of the constant voltage power supply (Figure 3) and the block diagram of the constant current power supply (Figure 10) suggests the possibility of combining these two circuit principles in one supply. Fortunately, most of the expensive, heavy power elements are common to both the constant voltage and constant current circuit configurations, and only low-level circuitry need be added to a constant voltage power supply so that it can also be used as a constant current source. Because of its unusual versatility and its fully adjustable output protection features, most H-Lab supplies employ this CV/CC circuit technique.



change in the output current of the supply from the point where current limiting action is first incurred to the current value at short circuit is of the order of 3% to 5% of the current rating of the power supply.

#### A10. SERIES REGULATOR CIRCUITRY

Up to this point, all circuits shown have included only a single series transistor. It is obvious, however, that a single series transistor has an adequate power capability only for the smallest power supply. Using several series transistors in parallel is usually not desirable because (1) the number of series power transistors—probably the least reliable component in the power supply—becomes quite large even for medium output power supplies, and (2) each series transistor will be subjected to the entire series regulator voltage under all operating conditions. Harrison Laboratories has placed considerable design emphasis both on reducing the power dissipated in series transistors and minimizing the number of series transistors required.

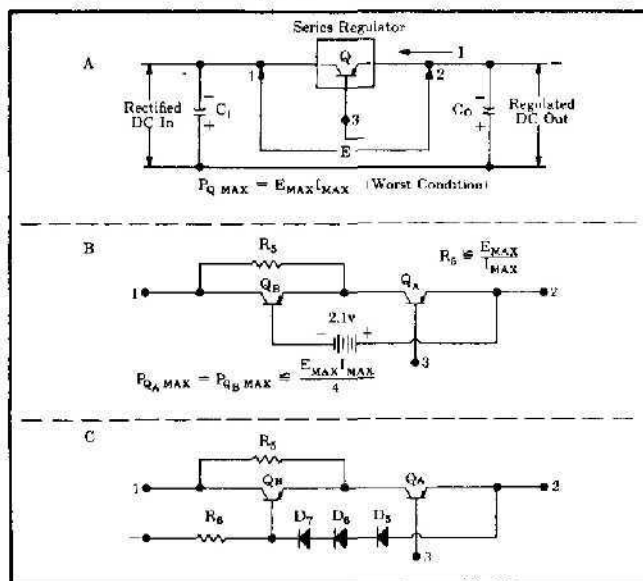

FIGURE 14. Series regulator circuits.

Figure 14A illustrates the simplest type of series transistor regulator; the maximum power dissipated in this series transistor is the product of its maximum voltage drop and the maximum current through it. Figure 14B illustrates the circuit principle of a two transistor series regulator employing a shunt resistor  $R_5$  around the second series transistor. With any moderate amount of load current the circuit of Figure 14B will tend to maintain approximately 2 volts across transistor  $Q_A$ . With a proper choice of  $R_5$  the maximum power which will be dissipated in transistor  $Q_A$  or  $Q_B$  will be approximately one-fourth the power which would be dissipated in the simple transistor regulator shown in Figure 14A—the excess power being dissipated in power resistor  $R_5$  rather than in a power transistor.

Furthermore, the operation of this circuit assures that transistors  $Q_A$  and  $Q_B$  will not be at their conditions of maximum power dissipation simultaneously; thus a heat sink for both these transistors will have a maximum

temperature rise associated with the heat dissipated by one, not two, power transistors.

The circuit of Figure 14B has the advantage of performing a preregulating action, with the result that ripple and other line disturbances presented to the collector of  $Q_A$  are less than those present at terminal 1, the rectifier DC input. This is true because the base of transistor  $Q_B$  is held practically constant, differing only by a battery voltage from the nearly constant output voltage present at terminal 2, the negative output terminal of the power supply.

Figure 14C illustrates an actual circuit in which three forward conducting silicon diodes, acting as the semiconductor equivalent of VR tubes, are substituted for the battery of Figure 14B. Resistor  $R_6$  provides the necessary path for maintaining the forward current flow through the three diodes.

Harrison Laboratories' supplies employ a large number of variations on the circuit principle suggested in Figure 14C; all such combinations of power resistors, transistors, and diodes result in increased reliability, because most of the series regulator dissipation occurs in power resistors rather than power transistors.

#### A11. VARIABLE TRANSFORMER PREREGULATOR

In power supplies of moderate or high power output the dissipation requirements of the series regulator circuit are more severe, and an efficient, reliable, and economical design is not feasible without resorting to some sort of preregulator in the rectifier path. The purpose of such a preregulator is to allow the rectifier output to change in coordination with the output voltage so that only a small voltage drop is maintained across the series regulator, and the power dissipation in the series regulator elements is held to a small value. One of the simplest techniques for accomplishing this is shown in Figure 15. A variable transformer mechanically coupled to the front panel voltage control insures that as the output voltage is turned down, the AC input to the rectifier (and therefore the rectifier output) is decreased by a similar amount.

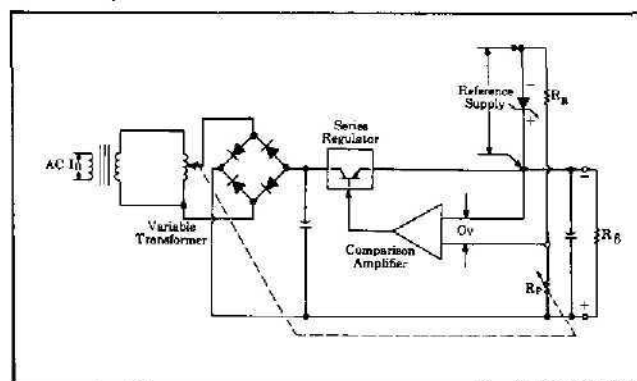

FIGURE 15. Constant voltage supply with variable transformer preregulator.

Disadvantages of this technique are that (1) remote programming is not feasible, and (2) under a short circuit load condition, the full rectifier voltage is impressed across the series regulator transistors.

## A12. SCR (SILICON CONTROLLED RECTIFIER) PREREGULATORS

The use of SCR prerregulators allows the circuit techniques already developed for low power output supplies to be extended readily to medium power and high power designs, without incurring the disadvantages of variable transformer prerregulators. Figure 16 shows a typical regulated DC power supply utilizing an SCR prerregulator.

Silicon Controlled Rectifiers, the semiconductor equivalent of thyratrons, are rectifiers which remain in a non-conductive state even when forward voltage is provided from anode to cathode until a positive trigger pulse is applied to a third terminal (the gate). Then the SCR "fires", conducting current with a very low effective resistance; it remains conducting after the trigger pulse has been removed until the forward anode voltage is removed or reversed.

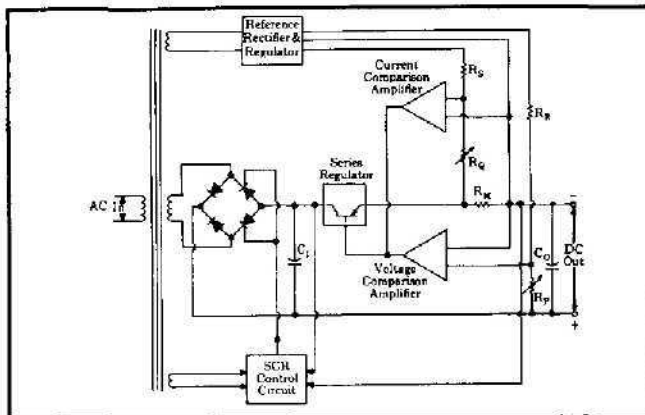

FIGURE 16. A CV/CC power supply with SCR prerregulator.

SCR's are included in two arms of the bridge rectifier of Figure 16. By controlling the firing time of the SCR's during each half cycle of input line frequency, the duration of conduction of the bridge rectifier is varied and the rectifier output is controlled in accordance with the demands which the DC output voltage and current of the supply impose.

The function of the SCR control circuit is to compute the firing time of the SCR trigger pulse for each half cycle of input AC so that the combined voltage drop across the series regulator and current monitoring resistor is held constant in spite of changes in load current, output voltage, and input line voltage. The final burden of providing the precise output voltage or current regulation rests with a series regulator controlled by voltage and current comparison amplifiers.

The correction action of H-Lab's SCR control circuit is much faster than that obtained with conventional SCR or magamp circuitry. Sudden changes in line voltage or load current result in a correction in the timing of the next SCR trigger pulse, which can be no farther away than one half cycle (approximately 8 milliseconds for a 60 cycle input). The use of large electrolytic capacitors across the rectifier output allows only a small voltage change to occur during this 8 millisecond interval. Using this prerregulator technique H-Lab can operate a series regulator chain with less than 2 volts across it at

all times, without risk of transient drop-out and loss of regulation due to changes in load or line. This use of an SCR prerregulator with excellent transient immunity thus results in a power supply having unusually high efficiency and reliability, since the power which must be dissipated in the series regulator is held to a very small value.

The leakage inductance of the power transformer, although it does not appear explicitly in Figure 16, plays an important part in the circuit performance. It acts as a small filter choke effectively in series with the SCR's and slows down the inrush current after firing, thus reducing the peak current through the SCR's and improving their reliability. Since this inductance reduces the high frequency content of the energy flow through the SCR's, RFI effects are suppressed; this and other circuit measures within H-Lab's SCR prerregulator reduce RFI to a level below that found in many power supplies using conventional rectifiers.

## A13. SCR REGULATED POWER SUPPLIES

In many applications the highly regulated performance capability of a transistor power supply is not required. For medium and high power requirements, H-Lab's basic SCR control circuit technique permits the design of an economical power supply having high efficiency and performance features superior to that obtainable from magamp supplies. More specifically, the SCR regulator power supplies using the block diagram of Figure 17 achieve excellent line transient immunity, 50 millisecond recovery for load current changes, and smaller size and weight; the output voltage of these supplies is continuously variable down to zero, and continuously variable current limiting or constant current operation is included on all units.

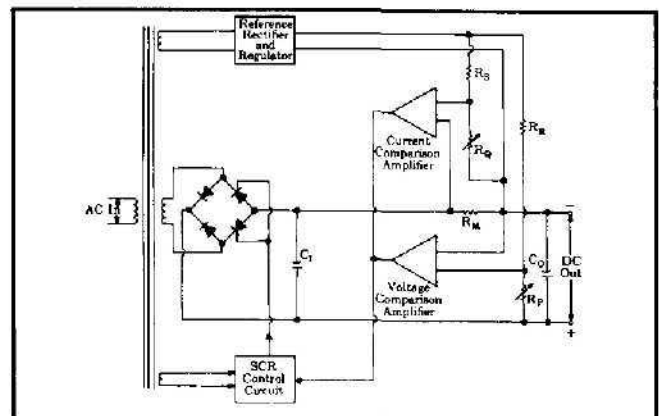

FIGURE 17. An SCR Regulated power supply.

Figure 17 reveals that the SCR control circuit receives a control signal dependent upon the output of either a voltage comparison amplifier or a current comparison amplifier. Such supplies, therefore, have output characteristics and control characteristics similar to the CV/CC and CV/CL power supplies discussed in Sections A8 and A9—except that the output voltage or current is less tightly regulated.

The SCR control circuit, receiving its input from either the voltage or current comparison amplifier,

computes the firing time for the SCR's, varying this in a manner which will result in a constant output in spite of changes in line voltage and load resistance. As in the case of H-Lab's SCR preregulator supplies, the patented SCR control circuit (which computes the firing time by comparing a ramp function with each half sine-wave of AC input) is unusually fast, with almost complete correction within the first half-cycle (8.3 msec) following a disturbance.

#### A14. "PIGGY-BACK" REGULATOR DESIGN

The circuit technique of Figure 3 is not suitable for a 300 volt, all-semiconductor, short-circuit proof power supply. Shorting the output terminals would place the rectifier voltage (more than 300 volts) across the series regulator transistors. A sufficient number of high voltage transistors would be too costly and unreliable. Even the preregulator circuit of Figure 16 is not suitable for a 300 volt supply, since, upon short circuit, the rectifier capacitor would discharge through the series regulator—the energy stored in this capacitor being more than adequate to destroy the power transistors in the regulator.

H-Lab's MVR Series utilizes a novel circuit technique which extends the usefulness of series regulating transistors rated for 30 or 40 volts to short circuit proof power supplies rated for outputs over 300 volts. As shown in Figure 18 the basic technique consists of placing a well-regulated low voltage power supply in series with a less well-regulated SCR supply having greater voltage capability. Notice, however, that the amplified error signal from the voltage comparison amplifier is dependent upon the *total* output voltage—not just the output of the low voltage power supply alone. Thus, the well-regulated piggy-back supply continuously compensates for any ripple, load regulation, or line regulation deficiencies of the main power source and adjusts the voltage across its series regulator so that the total output voltage remains constant despite disturbances in the main voltage source.

The rectifier supplying the series regulator of the piggy-back supply develops approximately 40 volts. Twenty volts is normally dropped across the series regulator, 20 volts across the terminals of the upper supply.

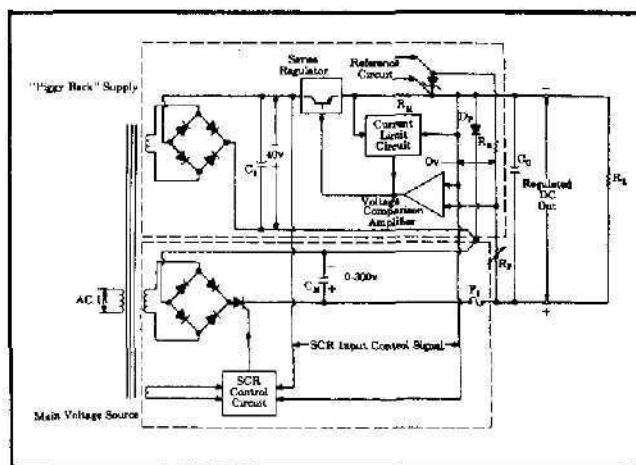

FIGURE 18. "Piggy-back" power supply.

Thus, the series regulator of the piggy-back supply has a  $\pm 20$  volt range for accomplishing the dynamic changes necessary to compensate for the variations of the lower power source. Short circuit protection for the series regulator in the piggy-back supply is provided by the diode  $D_P$  which, if the output terminals are shorted, provides a discharge path for the rectifier capacitor  $C_M$  of the bottom supply. Since the diode  $D_P$  prevents the output terminals of the piggy-back supply from ever reversing polarity, the series regulator within this circuit will never be called upon to withstand a voltage strain greater than the 40 volts from its own rectifier.

The fuse  $F_1$  is included so that under short circuit or prolonged overload conditions the path between the output terminals and the rectifying elements of the main voltage source will be opened, thus protecting the rectifiers and transformer.

The SCR control circuit for the bottom supply derives its input control signal not from the total voltage across the load resistor nor even from the voltage across the terminals of the SCR supply itself. Instead, this SCR control circuit monitors the voltage across the series regulator and the current monitoring resistor and maintains this voltage drop at approximately 20 volts, thereby leaving approximately 20 volts across the output terminals of the piggy-back supply.

## B. OPERATIONAL FEATURES AND OPTIONS

### B1. NO OVERSHOOT ON TURN-ON, TURN-OFF, OR AC POWER REMOVAL

Extra design precautions have been taken on all H-Lab DC power supplies to insure that there is no transient overshoot of the output voltage when the power supply is turned on or off or if AC power is accidentally removed. To avoid turn-on overshoot the bias and control circuits must come up more rapidly than the rectifier voltage, whereas to avoid turn-off overshoot the bias and control circuits must remain operating in order to restrain the conduction of the series regulator until after the energy stored in the rectifier capacitor has largely dissipated.

### B2. PROTECTION CIRCUITS

Many different types of protection circuits are included in H-Lab power supplies to protect the power supply itself and/or the load device connected to the output terminals of the supply.

#### a. Short Circuit Protection

All H-Lab semiconductor supplies are short-circuit proof and can operate into any overload indefinitely without risk of internal damage. In some supplies this short-circuit protection results from the use of a fixed current limit circuit. In others a front panel control permits adjustment of the current limit or constant current setting (See Application Manual Sections A8 and A9); either of the latter methods not only provides full protection to the power supply but also permits the adjustment of the maximum output current of the supply to the exact value which will result in optimum load protection.

#### b. Constant Current Overvoltage Protection

In constant current operation there often arises the need to protect the load device from the increase in output voltage which normally accompanies any large increase in the resistance of the load. H-Lab's CV/CC automatic crossover circuitry is ideal for this purpose, since it allows the user to set the voltage control to exactly the maximum permissible value for the particular load device connected to the supply. If the load resistance should increase to the point where this voltage ceiling is intercepted, further increases in load resistance will result in a constant output voltage and a decrease in the current through the load.

#### c. Reverse Voltage Protection

Most H-Lab supplies include a diode connected across the output terminals with reverse polarity. This diode, designated as  $D_0$  in Figure 19, protects the output electrolytic capacitors and the series regulator transistors from the effects of a reverse voltage applied across the output terminals. For example, in series operation of two supplies, if the AC is removed from one supply, diode  $D_0$  prevents damage to the unenergized supply which would otherwise result from a reverse polarity voltage.

Although  $D_0$  normally is selected to have a current rating equal to or greater than the current rating of its power supply, large energy sources placed across the output terminals with reverse polarity will result in its failure, usually leaving a short circuit across the output terminals until  $D_0$  is replaced. Such a replacement, however, brings attention to the fact that reverse energy flow is being forced through the output terminals so that a remedy can be accomplished.

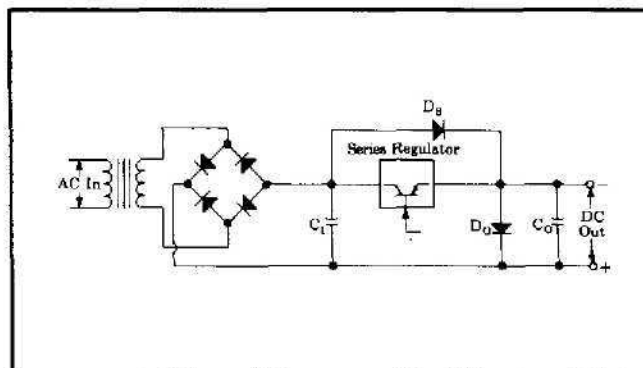

FIGURE 19. Protection diodes.

Since series regulator transistors or driver transistors should not be caused to withstand reverse voltage, diode  $D_0$  is included in most H-Lab supplies. This diode protects the series transistors in parallel or Auto-Parallel operation if one supply of the parallel combination is turned on before the other. Normally, this would result in the output capacitor of the unenergized supply becoming charged while the rectifier capacitor is uncharged, thereby placing a reverse potential across the series regulator. However, the inclusion of  $D_0$  allows the rectifier capacitor of the unenergized supply to be charged in parallel with the output capacitor—thus no reverse voltage can be placed across the series regulator.

#### d. SCR Rectifier and Preregulator Protection

With some power supplies, opening the remote programming path for an extended period of time may result in the necessity for additional protection circuits. Since opening the programming path is equivalent to inserting a very large value of programming resistance between the programming terminals (see Figure 23), the power supply responds by increasing its output voltage to the highest voltage available from the rectifier. In the case of power supplies without a preregulator, this will result in no damage to the power supply, but the output voltage of SCR regulated and preregulated supplies could rise to a value considerably higher than the maximum output rating of the supply if the programming terminals are accidentally opened. Consequently, all H-Lab supplies containing SCR's include an internal protection circuit which limits the maximum output voltage to a level approximately 15% above its nominal rating.

H-Lab power supplies using SCR regulators or SCR preregulators also include circuit elements which control the turn-on characteristics so that the SCR's will not have to withstand large current surges when AC power is first applied. Other elements within the SCR control circuit limit the maximum conduction angle of the SCR's after static operating levels have been reached.

RC networks or semiconductor transient suppressors are normally included in the input power path of H-Lab SCR regulated and preregulated supplies in order to protect the SCR's from line voltage transient surges or spikes and to suppress the feedback onto the AC power line of any spikes or high frequency energy. Three phase SCR supplies also include circuits which monitor all three phases of the AC input; protection action is initiated by these circuits if the line voltage goes above or below acceptable limits.

### e. External Overvoltage Protection

If a series regulator transistor fails, it usually becomes a short circuit rather than an open circuit. The output voltage can then rise to the full rectifier value. Under these circumstances the normal current limit circuit (which utilizes the series regulating transistor) is no longer operative, and the load current is limited mainly by the load resistance. In spite of a conservative engineering approach to the rating of power transistors, and in spite of H-Lab's unique design techniques which assure that series transistors operate at unusually low voltage and power levels, the possibility of series transistor failure, while small, still remains.

No matter how small this possibility, an expensive or irreplaceable load device may require positive protection against the statistics of power transistor failure. H-Lab's "Crowbar" overvoltage protector, which is completely independent of the power supply, monitors the output voltage of the supply. If the power supply exceeds a preset voltage threshold, an SCR (Crowbar) is triggered into the conducting state across the output terminals of the supply within 10  $\mu$ seconds. An operator can at any time verify that this overvoltage protector is armed and ready without actually shorting the power supply or discontinuing power flow into the load (see Page 29 for block diagram and further details).

### 83. REMOTE ERROR SENSING

Normally, a power supply achieves its optimum load and line regulation, its lowest output impedance, drift, ripple and noise, and its fastest transient recovery performance at the power supply output terminals. If the load is separated from the output terminals by any lead length, some of these performance characteristics will be degraded at the load terminals to a degree which depends upon the impedance of the load leads compared with the output impedance of the power supply.

Some idea of how easily even the shortest leads can degrade the performance of a power supply at the load terminals can be obtained by comparing the output impedance of an H-Lab power supply (typically of the order of 1 milliohm or less at DC and low frequencies) with the resistance of the various wire sizes listed in the following chart.

AWG (B & S) WIRE SIZE	Annealed Copper Resistance @ 20°C milliohms/ft	Nominal current rating (amps)*
22	16.1	5
20	10.2	7
18	6.39	10
16	4.02	13
14	2.53	20
12	1.59	25
10	0.999	40
8	0.628	55
6	0.395	80
4	0.249	105
2	0.156	140
0	0.0993	195
00	0.0779	260

\*Single Conductor in Free Air @ 30°C with rubber or thermoplastic insulation.

With remote error sensing, a feature included on nearly all H-Lab power supplies, it is possible to connect the feedback amplifier directly to the load terminals so that the regulator performs its function with respect to these load terminals rather than with respect to the output terminals of the power supply. Thus, the voltage at the power supply output terminals shifts by whatever amount necessary to compensate for the IR drop in the load leads, thereby retaining the voltage at the load terminals constant.

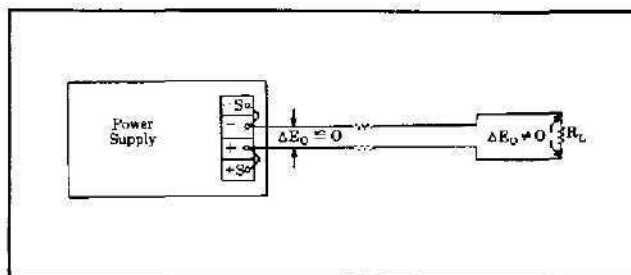

FIGURE 20A. Regulated power supply with local (normal) sensing.

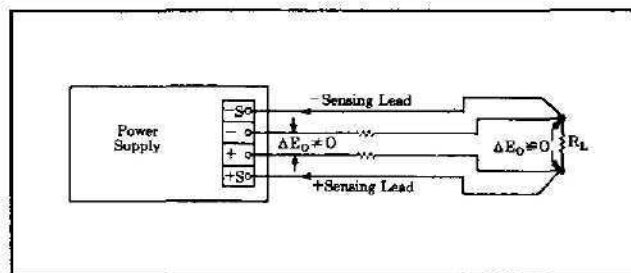

FIGURE 20B. Regulated power supply with remote error sensing.

Figure 21 shows the voltage comparison amplifier circuit details of a power supply having remote sensing capability. By comparing Figure 21 with Figure 7 it can be seen that the modifications to a standard design are minor, since remote error sensing simply involves operating the input comparison amplifier Q1, Q2 with reference to the load terminals instead of the output terminals of the power supply.

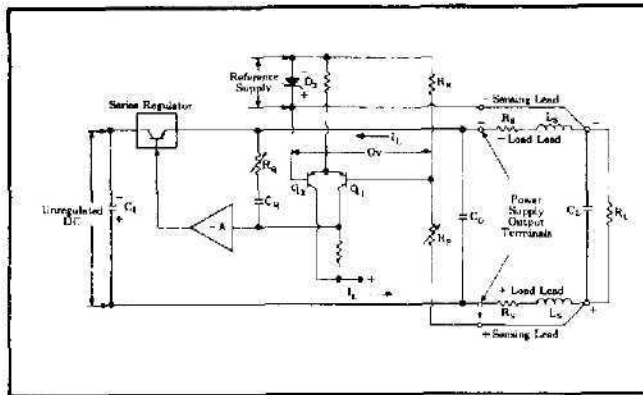

FIGURE 21. Effect of load leads on remote error sensing.

Remote sensing operation of power supplies with small and moderate output current ratings is readily accomplished for load devices separated from the power supply by reasonable lead lengths. With medium or high current supplies feeding loads which are removed from the output terminals of the supply by a considerable length of wire, added precautions must be observed in order to obtain satisfactory remote sensing operation. The IR drop in the negative load lead must be kept to less than 1 volt; otherwise resulting shifts in bias potentials in some models will prevent the proper operation of the voltage regulator and/or current limit circuit. There is also a practical limit to the voltage drop which can be allowed in the positive load lead, since the voltage drop occurring in either the positive or negative current carrying lead subtracts from the available output voltage of the power supply. Thus, a power supply which is normally rated for a maximum output of 36 volts can be used to deliver up to 32 volts at the load terminals if the wire sizes chosen result in a 1 volt drop in the negative load lead and a 3 volt drop in the positive load lead at maximum output current.

Since the current flowing in the sensing leads amounts to only several milliamperes, smaller wire sizes can be used for connecting the sensing terminals of the power supply to the load. However, care must be taken to shield the sensing leads, since any voltage pickup on these leads increases output ripple and noise. A shielded pair should be used for the sensing leads, with one end of the shield connected to the power supply ground terminal and the other end of the shield left unconnected.

It is common in remote sensing applications to utilize a large filter capacitor at the load. Figure 21 indicates, however, that the addition of this load capacitor results in a Pi filter (in conjunction with the output capacitor and the inductance of the load leads). The phase shift associated with this filter is inside the power supply feedback loop. *Extreme* remote sensing applications can in some cases affect the overall feedback stability of the loop and cause oscillation. In many cases readjusting the transient recovery control  $R_Q$  will restore normal operation. In other cases it will be necessary to eliminate  $C_O$  so that the Pi filter is reduced to an L filter. It is important for feedback stability that the load capacitor have a low impedance at all frequencies, and considerable care must be exercised in selecting a suitable capacitor  $C_L$ , since

using an electrolytic of inferior quality compared with the output capacitor normally present on Harrison Laboratories power supplies will make it difficult to achieve feedback stability. It is therefore recommended in extreme remote sensing applications that the electrolytic capacitor  $C_O$  be physically removed from the power supply and placed at the load terminals as  $C_L$ , the load filter capacitor. Once this has been accomplished it will be possible to eliminate any residual tendency toward oscillation by readjusting  $R_Q$ .

#### B4. AUTOMATIC ERROR SENSING

Normally, a power supply cannot provide optimum regulation at the front terminals when it is wired for rear terminal sensing, nor can it provide optimum regulation at the rear terminals when it is wired for front terminal sensing. In some cases, provision is made for strapping the sensing leads for either front or rear terminal operation.

However, H-Lab's small laboratory type power supplies feature Automatic Error Sensing, whereby the supply senses at the front terminals if the load is attached to the front terminals, and at the rear terminals if the load is attached there—with no necessity for switching or restrapping arrangements.

Figure 22 illustrates the simple circuit technique which results in Automatic Error Sensing. The regulated output of the series regulator is fed into the front terminals, while the sensing is fed to the rear output terminals, and wire of adequate current handling capability is connected between these two terminal pairs. Thus, if the load resistance is attached to the rear terminals, error sensing is accomplished at those terminals. On the other hand, if the load is attached to the front terminals, the heavy leads which connect the front and rear output terminals become extensions of the feedback sensing leads, and sensing is accomplished at the front terminals. Thus, a significant operating convenience is obtained with no increase in circuit complexity or cost.

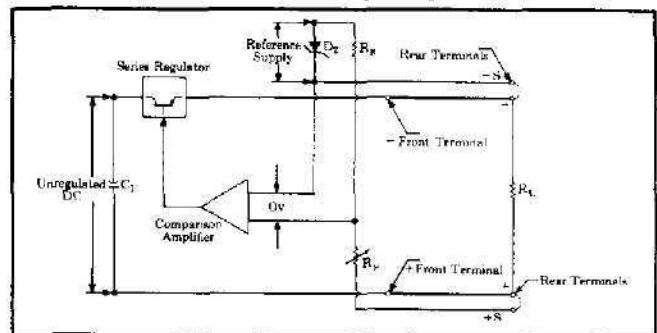

FIGURE 22. Constant voltage regulator with automatic error sensing.

#### B5. REMOTE PROGRAMMING WITH RESISTANCE CONTROL

Remote programming, a feature found on most H-Lab power supplies, permits the output voltage to be controlled in direct proportion to the resistance connected between the programming terminals. Using an external resistor and/or rheostat, the output voltage can be set to some fixed value, or made continuously variable over the entire output range, or made variable over some narrow span above and below a nominal value.

Figure 23 illustrates the essential circuit aspects of resistance programming of a constant voltage power supply. Note that this differs from the normal constant voltage circuit (Figure 7) in only one respect—the circuit points normally connected to the front panel control have been made available on rear terminals so that an external control can be substituted. The reason that the programming coefficient of Figure 23 is a constant has been explained in Section A2—the current flowing through  $R_P$  and  $R_R$  is constant and independent of the output voltage, and the voltage across the programming resistor (and therefore the output voltage) is a linear function of the resistance  $R_P$ .

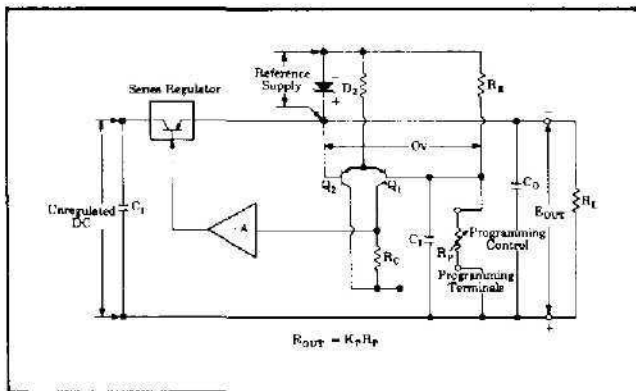

FIGURE 23. Constant Voltage supply with resistance programming.

Programming a power supply with a 200 ohms/volt programming coefficient to an output level of 30 volts would require an  $R_P$  of 6K. The power supply will force through this programming resistor a 5 ma constant current ( $\pm 2\%$ ) thus resulting in 30 volts across it, and 30 volts across the power supply output terminals.

The power consumed in the programming resistor can be readily determined by remembering that the programming current is the inverse of the programming coefficient  $K_P$ . Using the same example, a 200 ohm/volt programming coefficient corresponds to 5 ma programming current, and for 30 volts output (and thus 30 volts across the programming resistor), 150 milliwatts will be dissipated in  $R_P$ . A stable programming resistor must be used, since a percentage change in its resistance value will result in the same percentage change in the output voltage of the power supply being controlled.

In order to avoid short term temperature-dependent shifts in the resistance value (and hence the power supply output voltage) the programming resistor used should have a temperature coefficient of 20 ppm/ $^{\circ}C$  or less and a wattage rating in excess of ten times the actual dissipation. Thus, in the previous example, the programming resistor should have a minimum power rating of 1.5 watts.

The leads connecting the programming resistor to the power supply should be kept short and away from stray electric fields. Any ripple which is picked up on the programming leads becomes part of the command voltage for the power supply regulator and is therefore reproduced on the output terminals; the leads to the programming resistor should therefore be twisted or,

preferably, shielded two-wire cable should be used, with the shield being connected at the power supply end to the ground terminal—the other end of the shield being left unconnected.

Using remote programming, several different values of fixed output voltage can be set up with resistors and a switch, so that the output voltage of the supply can be switched to any pre-established value with a high degree of reproducibility. Figure 24 illustrates several switching schemes which can be used in conjunction with resistance programming of power supplies. Suppose it is desired to program a supply having a programming coefficient  $K_P$  of 200 ohms/volt to any of three values—5 volts, 10 volts, and 15 volts; the circuit of Figure 24A is probably the most natural one which comes to mind. However, if a break-before-make switch is used in the configuration of Figure 24A, there will occur for a short interval during the switching action a very high resistance between the two programming terminals, and the power supply during that interval will raise its output voltage in response to this high resistance input.

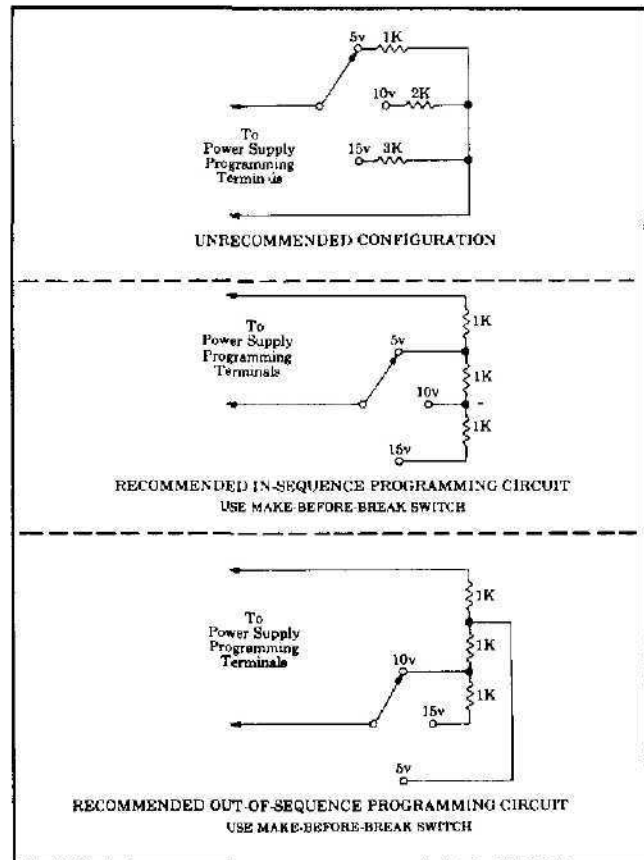

FIGURE 24. Remote Programming switching circuits.

To eliminate this output overshoot corresponding to an infinite programming resistance, a make-before-break switch can be employed. However, this solution has the disadvantage that during the short interval when the swinger of the switch is contacting two switch terminals, two programming resistors will momentarily be paralleled across the power supply programming termi-

nals, and the supply will for this short interval seek an output voltage which is lower than either the initial or the final value being programmed. This output undershoot increases the time required for the supply to settle to its new value.

The switching circuit of Figure 24B, using a make-before-break switch, eliminates both the overshoot and the undershoot problems associated with Figure 24A, since when rotated clockwise the resistance value between the two programming terminals will go directly from 1000 to 2000 ohms, and then from 2000 to 3000 ohms.

It appears at first glance that the circuit of Figure 24B also has one drawback—namely, the output voltage must always be switched in ascending or descending sequence. As Figure 24C shows, however, the same voltage divider can have its tap points returned to the switch contacts in any sequence whatever, thus permitting output voltage values to be programmed in any desired order without overshoot or undershoot.

In some applications it is possible for the programming switching circuits to be opened accidentally, thus causing the output voltage to rise to some value higher than the maximum voltage rating of the supply. With some loads this could result in serious damage. To protect these loads from accidental opening of the remote programming leads, a zener diode may be placed directly across the power supply programming terminals, this zener diode being selected to have a breakdown voltage equal to the maximum power supply voltage which can be tolerated by the load. Thus, if the programming terminals open, the programming current will cause the zener diode to break down, and the output voltage will be limited to the zener diode voltage. Such a zener diode must be capable of dissipating a power equal to the product of its breakdown voltage times the programming current  $I_P$ .

#### B6. REMOTE PROGRAMMING WITH VOLTAGE CONTROL

Instead of controlling a power supply by means of a programming resistance, it is possible to control the output of any H-Lab remotely programmable supply with an input voltage. Thus, the power supply becomes a low frequency DC amplifier. A later section (B8) stresses the bandwidth and speed of response aspects of this configuration, whereas this section deals with the method of control.

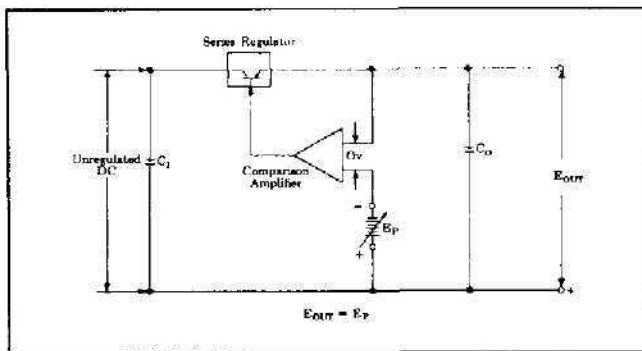

FIGURE 25. Voltage programming with unity voltage gain.

Two distinct methods can be employed to voltage program an H-Lab regulated DC power supply. The first method, shown in Figure 25, requires that the external voltage be exactly equal to the desired output voltage. The current required from the voltage source  $E_P$  is at most several milliamps. Of course, this voltage source must be free of ripple and noise and any other undesired imperfections, since within the regulator bandwidth the power supply will attempt to reproduce on its output terminals the programming voltage input on a one-for-one basis.

Figure 26 illustrates the method by which the power supply can be programmed using an external voltage with a voltage gain dependent upon the ratio of  $R_P$  to  $R_R$ . Note that this method is no different from the circuit normally used for constant voltage control of the output except that an external reference (the programming voltage source) has been substituted for the internal reference.

In most H-Lab supplies terminals have been brought out to the rear barrier strip so that the connections shown in Figure 26 can be accomplished without any internal wiring changes. In all remotely programmable H-Lab power supplies the summing point  $S$  is made available, and the configuration of Figure 26 can always be accomplished using the external programming voltage source and external precision wirewound resistors  $R_P$  and  $R_R$ . ( $R_R$  should not exceed 10K.) As indicated by the equation in Figure 26,  $R_P$  can be selected so that the resulting voltage gain is less than or greater than unity. It is possible to use the front panel control already present in the supply as the voltage gain control,  $R_P$ .

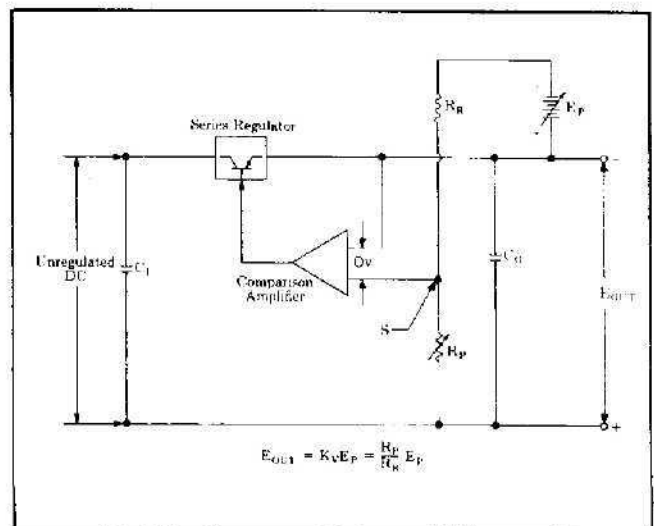

FIGURE 26. Voltage programming with variable voltage gain.

#### B7. REMOTE PROGRAMMING ACCURACY

Figure 27 shows the relationship between programming resistance and output voltage for a power supply with perfect remote programming. Zero ohms across the programming terminals results in exactly zero volts out, and all other values of programming resistance result in the output voltage predicted by the programming coefficient  $K_P$ .

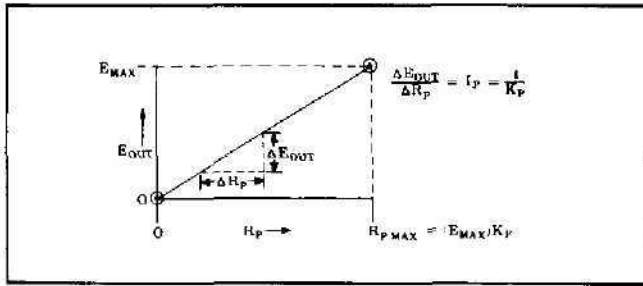

FIGURE 27. "Ideal" remote programming characteristic.

As Figure 28 indicates, all power supplies deviate somewhat from the ideal. The application of a short circuit across the programming terminals results in an output voltage which is slightly different from zero (typically between +20 millivolts and -50 millivolts). While the *linearity* of the programming characteristic is nearly perfect, the overall *slope* differs from the value predicted by the programming coefficient by from 1% to 5% depending on the model number. At a slight extra charge, the factory will specially align any remote programming supply so as to reduce the zero offset and slope errors to smaller values. Methods of accomplishing this alignment of the output programming characteristic are discussed in H-Lab Tech Letter #1 and can readily be accomplished by the user.

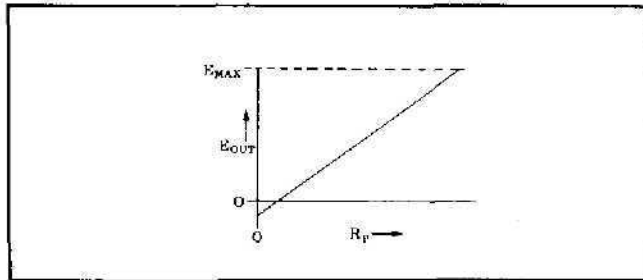

FIGURE 28. Practical remote programming characteristic.

Once a power supply has its programming characteristic aligned "perfectly" in accordance with the characteristic shown in Figure 27, this alignment will retain an absolute accuracy within a tolerance found by adding the power supply's specifications for load regulation, line regulation, temperature coefficient, and stability—any change in the load resistance, input line voltage, ambient temperature, or warmup time can be expected to cause slight variations in the output voltage of the supply even though the value of the programming resistance has not been altered. The capability for remote programming accuracy therefore increases with improvements in the four specifications mentioned, and chopper stabilized power supplies are capable of greater long-term programming accuracy than standard supplies.

### 88. SPEED OF REMOTE PROGRAMMING

A constant voltage regulated power supply is normally called upon to change its output *current* rapidly in response to load resistance changes. In some cases, however, notably in high speed remote programming applications and constant current applications involving

rapidly changing load resistance, the power supply must change its output *voltage* rapidly. If the power supply does *not* employ a preregulator, the most important factor limiting the speed of output voltage change is the output capacitor and load resistor.

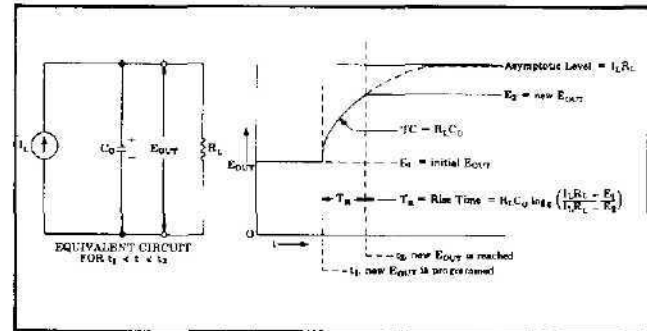

FIGURE 29. Speed of response—programming up.

The equivalent circuit and the nature of the output voltage waveform when the supply is being programmed upward are shown in Figure 29. When the new output is programmed, the power supply regulator circuit senses that the output is less than desired and turns on the series regulator to its maximum value  $I_L$ , the current limit or constant current setting. This constant current  $I_L$  charges the output capacitor  $C_O$  and load resistor  $R_L$  in parallel. The output therefore rises exponentially with a time constant  $R_L C_O$  toward a voltage level  $I_L R_L$ , a value higher than the new output voltage being programmed. When this exponential rise reaches the newly programmed voltage level, the constant voltage amplifier resumes its normal regulating action and holds the output constant. Thus, the rise time can be determined using a universal time constant chart or the formula shown in Figure 29.

If no load resistor is attached to the power supply output terminals, then the output voltage will rise linearly at a rate of  $\frac{C_O}{I_L}$  when programmed upward, and  $T_R = \frac{C_O (E_2 - E_1)}{I_L}$ .

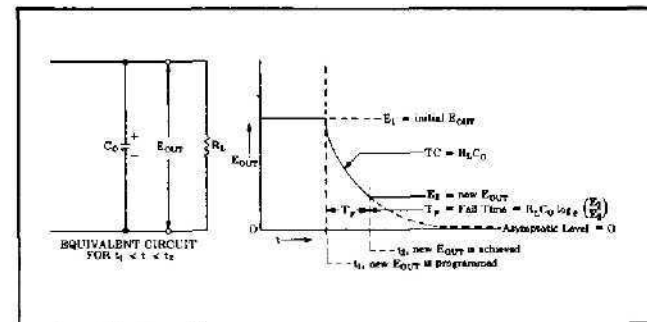

FIGURE 30. Speed of response—programming down.

Figure 30 shows that when the power supply is programmed down, the regulator senses that the output voltage is higher than desired and turns off the series transistors entirely. Since the control circuit can in no way cause the series regulator transistors to conduct

backwards, the output capacitor can only be discharged through the load resistor. The output voltage decays exponentially with a time constant  $R_L C_0$ , and stops falling when it reaches the new output voltage which has been demanded.

If no load resistor is attached to the power supply output terminals, the output voltage will fall slowly, the output capacitor being discharged only by small bleed resistors and currents within the power supply.

Whether the supply is required to increase or decrease its output voltage, the output capacitor tends to slow the change. Many H-Lab power supplies therefore make it possible to remove a major portion of the output capacitance simply by removing a strap on the rear barrier strip. After this has been accomplished the output voltage can in general be programmed ten to one hundred times more rapidly, but the regulator loop may need to have its transient recovery control readjusted so that the supply does not oscillate under certain load conditions.

Beyond a certain point, further reduction in the size of the output capacitor  $C_0$  will not result in greater speed of programming, since other power supply circuit elements will eventually limit the maximum rate of change of the output voltage. For example,  $C_1$  of Figure 23 eventually limits the speed of programming, but reduction or elimination of this capacitor would degrade the ripple performance. Thus, high speed programming applications can involve special circuit considerations which ultimately lead to a distinctly different power supply design.

Supplies using SCR preregulator circuits cannot in general be expected to respond as rapidly as shown in Figures 29 and 30, since a change in output voltage must be accompanied by a change in rectifier voltage; the large value of the rectifier filter plus protection circuits within the SCR preregulator prevent the rectifier voltage from changing rapidly.

## B9. PARALLEL OPERATION

The operation of two constant voltage power supplies in parallel is normally not feasible because of the large circulating current which results from even the smallest voltage difference which inevitably exists between the two low impedance sources. However, if the two power supplies feature CV/CC or CV/CL automatic crossover operation, then parallel operation is feasible, since the supply with the higher output voltage setting will deliver its constant current or current limited output, and drop its output voltage until it equals the output of the other supply, which will remain in constant voltage operation and only deliver that fraction of its rated output current which is necessary to fulfill the total load demand. For example, if two CV/CC power supplies each rated for 10 amperes were connected in parallel across a 15 amp load with one of the supplies set for 30.0 volts and the other supply set for 30.1 volts, the 30.1 volt supply would deliver 10 amperes as a constant current source, thus dropping its output voltage to 30.0 volts. The second supply would continue to act as a constant voltage source delivering 5 amps at the 30.0 volt level.

## B10. AUTO-PARALLEL OPERATION

Auto-Parallel, or automatic parallel operation of power supplies permits equal current sharing by such supplies under all load conditions, and allows complete control of the Auto-Parallel ensemble utilizing only the controls of the master supply.

Figure 31 illustrates the circuit principle involved. The master supply operates in a completely normal fashion and may be set up for either constant voltage or constant current operation as required. The slave supply employs its regulator circuit to compare the voltage drop across the current monitoring resistor of the master supply with the voltage drop across the current monitoring resistor of the slave supply, and adjusts the conduction of the series regulator in the slave supply so that these two IR drops are held equal. Therefore, with equal values of current monitoring resistors in the master and slave supplies, the output current contribution will always be equal regardless of the output voltage or current requirement of the load.

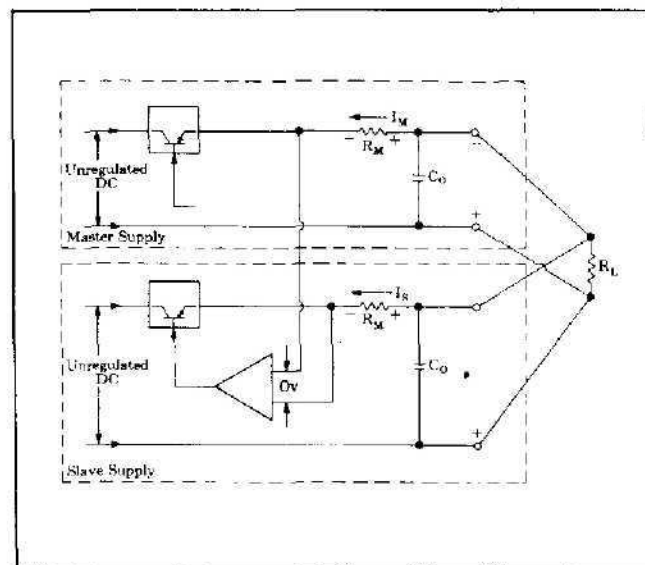

FIGURE 31. Auto-parallel operation of two supplies.

Normally, only supplies having the same model number should be connected for Auto-Parallel operation, since the two supplies must have the same voltage drop across the current monitoring resistor at full current rating.

As in the case of Auto-Series and Auto-Tracking operation, no internal wiring changes are necessary. All that is required is a screwdriver to change the strapping pattern on the terminals of the rear barrier strip, and one extra lead running from the barrier strip of each slave supply to another supply in the same master-slave system.

## B11. SERIES OPERATION

Series operation of two or more H-Lab power supplies can be accomplished up to 300 volts off ground (See Section B14). Series connected supplies can be operated with one load across both supplies or with a separate

load for each supply. All H-Lab semiconductor power supplies have reverse polarity diodes connected across the output terminals so that if operated in series with other power supplies, reverse polarity will not occur across the output terminal of any supply should the load be short-circuited or should one power supply be turned on separately from its series partners.

### B12. AUTO-SERIES OPERATION

Auto-Series or automatic series operation of power supplies permits equal or proportional voltage sharing of such supplies under all load conditions, with complete control of the Auto-Series ensemble being obtained from the master supply alone. Figure 32 illustrates the circuit principle involved. The slave supply is connected in series with the positive output terminal of the master supply, and a voltage divider ( $R_1$  and  $R_2$ ) is placed across the series voltage span. One input of the comparison amplifier of the slave supply is connected to the junction of these two resistors while the other input is connected to the negative output terminal of the slave supply. Since normal feedback action of the slave supply is such as to maintain a zero error between the two comparison amplifier inputs, the slave supply will contribute a fraction of the total output voltage determined by the voltage divider  $R_1$  and  $R_2$ .

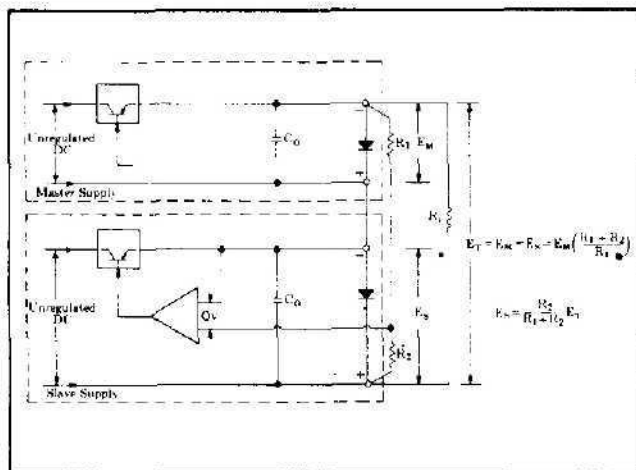

FIGURE 32. Auto-series operation of two supplies.

For example, if these two resistors are equal, the slave supply will contribute half the total output voltage with the master supply contributing the other half. Notice that the percent of the total output voltage contributed by each supply is independent of the magnitude of the total voltage. When using fixed resistors  $R_1$  and  $R_2$ , the front panel voltage control of the slave supply will be inoperative. Turning the voltage control of the master supply will result in a continuous variation of the output of the series combination, with the contribution of the master's output voltage to that of the slave's voltage always remaining in the ratio of  $R_1$  to  $R_2$ .

Since any variation in the resistance value of  $R_1$  and  $R_2$  will result in a change in the voltage divider ratio and hence the output of the slave supply, it is important

that both these resistors have a low temperature coefficient (20 ppm/°C or better) and have a power rating at least 10 times their actual dissipation. Resistors  $R_1$  and  $R_2$  should be selected so that at the normal operating levels the current through them will be of the order of 1 to 5 ma.

Comparing Figure 32 with previous block diagrams for the constant voltage power supply (e.g. Figure 3), one can see that there is no difference in the circuit location of resistor  $R_2$  and the front panel voltage control normally found in H-Lab power supplies. Thus, Auto-Series operation can be achieved using only one external resistor ( $R_1$ ) and employing the front panel voltage control on the slave supply as the element which determines the ratio of its voltage to that of the master.

Mixed model numbers may be employed in Auto-Series combination without restriction, provided that each slave is specified as being capable of Auto-Series operation. The master supply need not be an Auto-Series supply since the internal circuit aspects of the master supply in no way affect the Auto-Series principle of operation. If the master supply is set up for constant current operation, then the master-slave combination will act as a composite constant current source.

In some applications, remote programming of the master supply is employed, thereby achieving simultaneous control of the output of two sources from a single remote resistance or voltage input. When the center tap of such an Auto-Series combination is grounded, coordinated positive and negative voltages result. This technique is commonly referred to as "rubber-banding," and an external reference source may be employed if desired. Any change of the internal or external reference source (e.g. drift, ripple) will cause an equal percentage change in the outputs of both the master and slave supplies. This feature can be of considerable use in analogue computer and other applications, where the load requires a positive and a negative power supply and is less susceptible to an output voltage change occurring simultaneously in both supplies than to a change in either supply alone.

### B13. AUTO-TRACKING OPERATION

Auto-Tracking or automatic tracking operation of power supplies is similar to Auto-Series operation except that the master and slave supplies have the same output polarity with respect to a common bus or ground. Figure 33 shows two supplies connected in Auto-Tracking with their positive output terminals connected together as a common or ground point. A fraction  $\frac{R_2}{R_1 + R_2}$  of the output of the master supply is provided as one of the inputs to the comparison amplifier of the slave supply, thus controlling the slave's output. The master supply in an Auto-Tracking system must be the negative supply having the largest output voltage. Auto-Series addition of still more slaves permits the expansion of an Auto-Tracking system to both negative and positive power supplies.

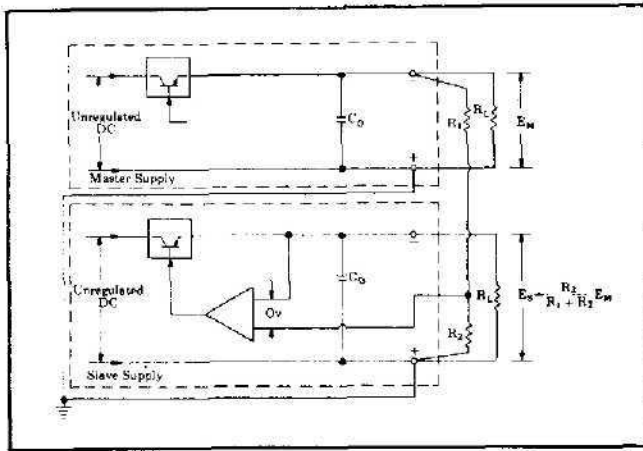

FIGURE 33. Auto-tracking operation of two supplies.

Like Auto-Series operation, Auto-Tracking permits simultaneous turn-on and turn-off of power supplies in the same system, thereby preventing accidental application or removal of main power sources without proper bias potentials being present.

#### B14. GROUNDED AND FLOATING OPERATION

All H-Lab power supplies are floating—that is, a power transformer isolates the DC power supply output from the AC input, and neither the positive nor negative output terminal (nor any point within the regulator circuit) is connected to chassis or ground. Thus, the power supply may be used as either a positive or a negative DC source by grounding the negative or positive output terminal respectively.

In some applications, however, it is desirable to “float” the power supply (neither output terminal grounded). All H-Lab supplies can be operated at up to 300 volts off ground; special factory modifications in many cases will permit operation to still higher values. One limiting factor is the mica washer which on most units separates the power transistors from the heat sink.

Since the output ripple of most H-Lab power supplies will increase somewhat when operated floating (neither

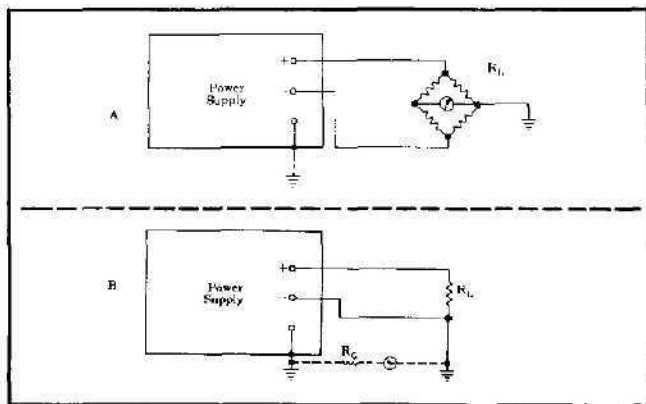

FIGURE 34. Power supply feeding two types of grounded loads.

output terminal shorted to ground), it is desirable in such applications to place a 1 $\mu$ f capacitor with short leads between the negative output terminal and ground so that the low output ripple performance of the supply may be restored.

Sometimes floating operation is desired not in order to elevate the output potential of the power supply, but to eliminate or reduce the effects of ground problems. Figure 34 illustrates two situations in which it is not practical to connect a power supply output terminal to ground either with a direct short or a by-pass capacitor.

In Figure 34A, a power supply is shown feeding a bridge circuit, one end of which must be grounded at a point other than the power supply case. This configuration arises frequently in strain gage applications. Grounding either output terminal of the supply with either a short or a capacitor would have the effect of shorting out one arm of the measurement bridge at DC and/or signal frequencies.

Figure 34B shows a power supply feeding a remote load which must be grounded at a point removed from the power supply case. Due to unavoidable ground potentials, connecting either output terminal of the supply of Figure 34B to ground through a short or by-pass capacitor will result in a circulating ground current which will develop an IR drop in the lead between the load and the grounded power supply terminal. This IR drop, usually having the power line frequency as its fundamental component, is added in series with the power supply output to the load, thus degrading the ripple and noise presented to the load and any measuring device connected across it.

All H-Lab power supplies employ Faraday shields in the power transformer to reduce any undesired coupling effects from AC line input to DC output. In some cases, however, stringent isolation requirements associated with ungrounded operation (as given in Figure 34) may necessitate the use of a power supply employing added design restrictions. Model 801C strain gage power supply, for example, has been especially designed to reduce stray leakage effects, and employs a quadruply shielded transformer so that input-output capacitance is reduced to less than 1 pf. Further information concerning methods of measuring these leakage components can be obtained from the factory.

#### B15. ADJUSTABLE TRANSIENT RECOVERY

The ability of a power supply to recover quickly from a sudden change in load current demand in constant voltage operation is dependent upon the shape of the gain bandwidth curve of its feedback amplifier. It is necessary in designing a power supply to shape this open loop gain vs. frequency characteristic so that the power supply will not oscillate under any load condition—resistive, capacitive, or inductive. Part of the solution to this design problem usually involves an RC equalizing network ( $R_Q$ ,  $C_Q$  of Figure 21). In many supplies the resistance of this network is made variable and is adjusted at the factory so that when a resistive load is

suddenly applied or removed, the resulting output voltage transient has the fastest possible recovery with no overshoot. (Section D5 gives further details on the recommended method for switching the load and measuring transient recovery characteristics.) This adjustment of the transient recovery control achieves ample phase margin against instability for all loads. Turning this control away from the critically damped setting of Figure 35A in one direction will cause the underdamped response of Figure 35B, and if the control is turned still further in this direction the power supply may be caused to oscillate. Turning the transient recovery control in the other direction will result in the overdamped response of Figure 35C, with a resulting increase in the transient recovery time.

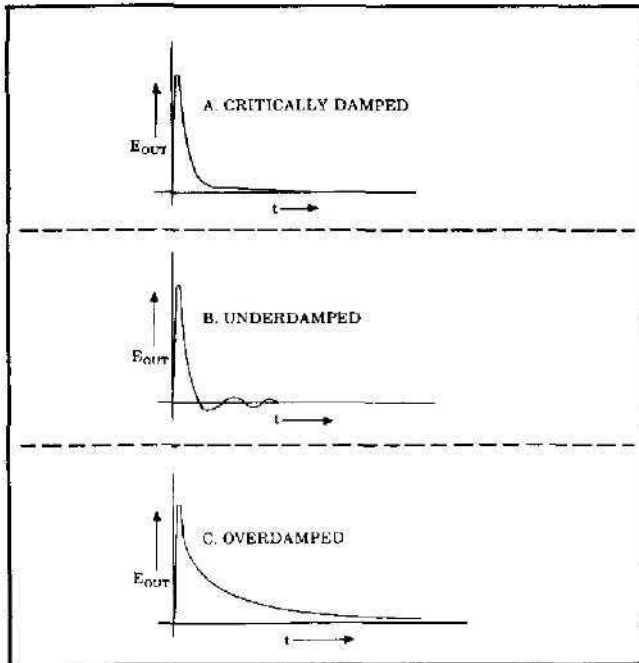

FIGURE 35. Constant voltage full load to no load transient recovery characteristics.

While the factory setting of this control achieves ample phase margin against instability for all types of loads, this same setting may not be the one which achieves the fastest possible transient recovery for large phase angle loads. When using non-resistive loads, the adjustment of this control permits achievement of optimum transient recovery performance. In addition, it may be desirable to readjust this control to compensate for the effects of transistor aging, etc.

#### B16. ADJUSTABLE METERS

The meters used on H-Lab supplies have an accuracy of 2% full scale. In most supplies, an adjustable resistor in series with the meter movement is included on the printed wiring board. This control is adjusted at factory for the most accurate reading at the maximum rated output of the supply. However, the user can recalibrate

the meter for best accuracy at any other point on the scale.

#### B17. IMPROVED STABILITY WITH CHOPPER STABILIZATION

The output drift of any power supply results mainly from changes in the reference voltage, the output monitoring resistors ( $R_P$  and  $R_R$  of Figure 36A), and the input characteristics of the comparison amplifier ( $Q_1$  and  $Q_2$ ). While the use of low temperature coefficient zener diodes, low temperature coefficient wirewound resistors, and a differential input amplifier make the standard H-Lab power supply remarkably free from output drift, some stringent applications require even better performance. For this reason, Harrison Laboratories makes available a completely semiconductor chopper stabilizing modification which can be factory installed on a large number of catalog items. This option results in a significant improvement in temperature coefficient and stability specifications.

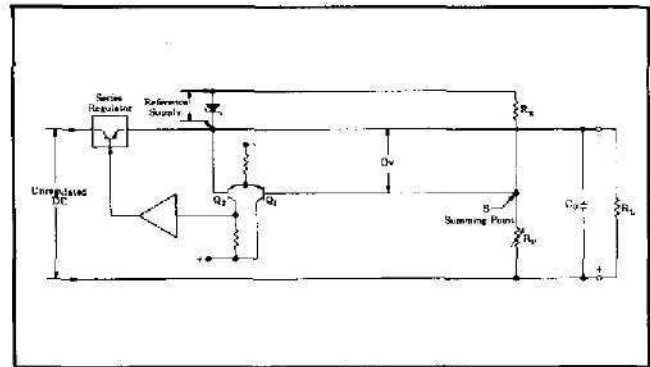

FIGURE 36A. A constant voltage power supply.

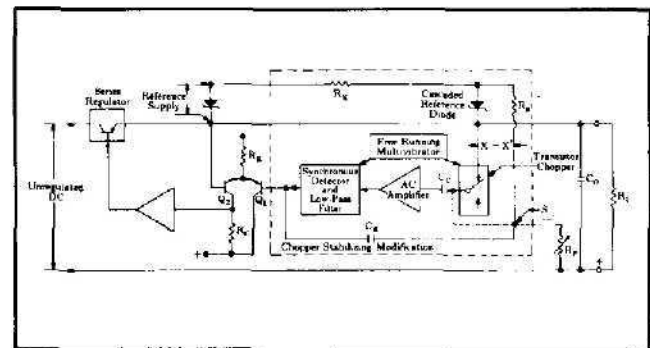

FIGURE 36B. A constant voltage power supply with chopper stabilizing modification.

Since in a standard supply the drift contribution of  $R_P$  and  $R_R$  is comparatively negligible, the chopper stabilizing modification adds elements to (1) improve the performance of the reference, and (2) overcome the drift effects of transistor stages  $Q_1$  and  $Q_2$ .

As shown in Figure 36B, the added printed wiring board includes resistor  $R_X$  and a cascaded reference diode having an even lower temperature coefficient than the normally used reference diode. These two elements provide improvements in the reference performance to

correspond with the input drift improvement brought about by the addition of the chopper amplifier.

Normally, transistor Q1 or Q2 has an emitter-to-base potential difference which changes about  $2 \text{ mV}/^\circ\text{C}$ . The use of the differential amplifier configuration permits a first-order cancellation of this change. Even so, it can be anticipated that the temperature dependent change between the base of Q1 and Q2 will be of the order of 200 to  $400 \mu\text{V}/^\circ\text{C}$ . This change in the DC offset potential of the comparison amplifier results in an identical change in the output voltage of a standard supply. In a feedback amplifier, the effect of a noise source on the output voltage can be reduced by inserting noise-free gain inside the feedback loop *ahead* of the noise source. Since drift is merely "DC noise," the effect of the emitter-base drift of transistors Q1 and Q2 can be reduced by inserting between the summing point and the input of the amplifier an additional amount of noise-free DC gain.

The potential between X and X' is the error signal input to the feedback amplifier; it is the difference between the desired output level and the existing output level. This potential will approach zero as feedback equilibrium is achieved. In Figure 36B a silicon transistor chopper continuously switches between terminals X and X'. Thus, the input to the AC amplifier is a square wave with an amplitude proportional to the magnitude of the error, and a phase dependent upon the

direction of the error. This error signal is amplified by the AC amplifier, whose output signal is independent of any small DC bias shifts. The amplified AC next passes through a detector (or demodulator) which is synchronized with the transistor chopper (or modulator) and then through a low pass filter to the base of Q1. The reconstructed but amplified DC error is thus presented on the base of Q1, and since it is of larger magnitude than the DC signal which would be presented at this base in a standard circuit, it overrides the small DC drift inherent in the differential amplifier.

Because the transistor chopper and detector operate at approximately a 1 Kc rate, the signal amplification of the chopper stabilizing amplifier is effective only over a bandwidth from DC to somewhat less than 100 cps. Since frequencies above 100 cps will not pass through the chopper amplifier circuit, it is necessary to provide a parallel signal path to preserve the normal AC regulating action so necessary for low ripple and noise, low output impedance at mid and high frequencies, and fast transient recovery performance. Capacitor  $C_B$  is therefore included so that for frequencies above 100 cps, the signal transmission from the summing point S to the base of Q1 will be as good in the chopper stabilized circuit (Figure 36B) as in the normal regulator circuit (Figure 36A).

## C. SPECIAL APPLICATION PROBLEMS

### C1. DC POWER DISTRIBUTION AND MULTIPLE LOADING

Figure 37A illustrates the most common error in using DC regulated power supplies. The effective source impedance feeding each of the three loads is the output impedance of the power supply *plus* the effect of any lead resistance and inductance which separates each load from the power supply terminals. Since nearly all practical load devices draw from a constant voltage power supply an output current which varies somewhat with time, there will be a variation of the voltage drop in the leads connecting the loads of Figure 37A to the power supply.

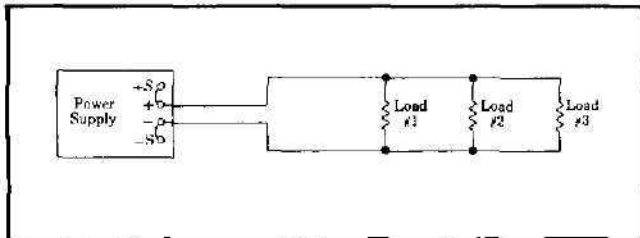

FIGURE 37A. Incorrect method of DC power distribution.

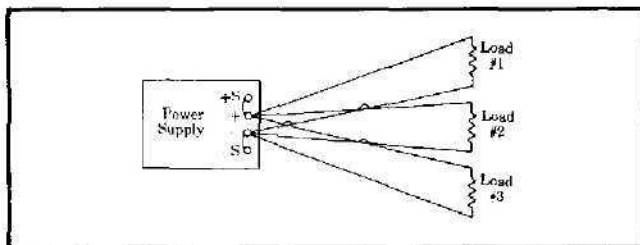

FIGURE 37B. Correct method of DC power distribution using local (normal) sensing.

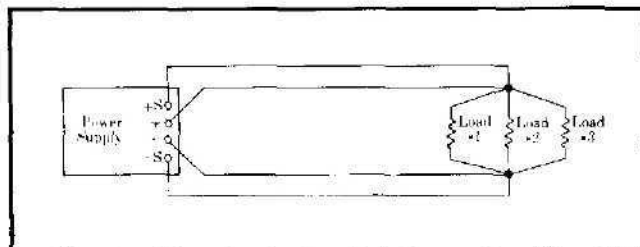

FIGURE 37C. Correct method of DC power distribution using remote sensing.

Since the output impedance of a well-regulated power supply is extremely low, frequently less than a milliohm, any load wire common to two or more loads seriously increases the mutual coupling. This mutual coupling effect can be particularly serious in logic circuitry, where improper load wiring may result in large spikes being developed across the impedance of the load leads, with such spikes causing false triggering of other logic circuits fed from the same power supply leads.

To achieve proper DC power distribution without mutual coupling effects, one must first decide where the distribution terminals of the power system will be located. If the output terminals of the power supply are to be used as the distribution point, then local sensing

is employed and each of the several load devices being fed by the power supply must have *separate pairs* of leads connected directly from the load to the power supply terminals as shown in Figure 37B.

If the distribution terminals are to be located separately from the power supply output terminals, then remote sensing should be employed between the power supply output and the remote distribution terminals by a *separate pair* of leads (Figure 37C). It will be desirable in most cases to add a large electrolytic capacitor across the remote distribution terminals to further minimize mutual coupling effects at high frequencies. However, the precautions described under Section B3 "Remote Error Sensing" should be observed.

### C2. DUAL OUTPUT USING RESISTIVE DIVIDER

Often it is required to use both a positive and negative DC power source having roughly the same voltage and current capability. It might seem reasonable to meet such requirements using a single regulated DC power supply with a resistive voltage divider center-tapped to ground. Figure 38 shows, however, that such an arrangement results in a drastic increase in the effective DC source impedance feeding each load; assuming that the power supply has a zero output impedance, each load looks back into a source impedance consisting of the two arms of the voltage divider in parallel with each other and the other load resistance.

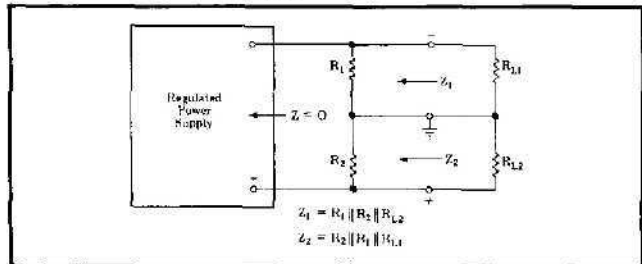

FIGURE 38. Center-tapping the output of a power supply.

Thus, a change in the current requirement of either load results not only in a change in its own DC voltage, but also in a change of the DC voltage feeding the other load, and extreme conditions of unbalance can develop. In nearly all cases, a simultaneous need for positive and negative DC voltages necessitates the use of two separate regulated power supplies.

### C3. DUTY CYCLE LOADING

In some applications the load current varies periodically from a minimum to a maximum value. At first it might seem that a transistor regulated power supply having a current rating in excess of the *average* load requirement (but less than the *peak* load value) would be adequate for such applications. However, it must be remembered that the current limit or constant current circuit within a semiconductor power supply limits the output current on an instantaneous, not an average basis, since such protection circuits must be extremely fast in order to provide adequate safeguard against burn-out of the series regulating elements.

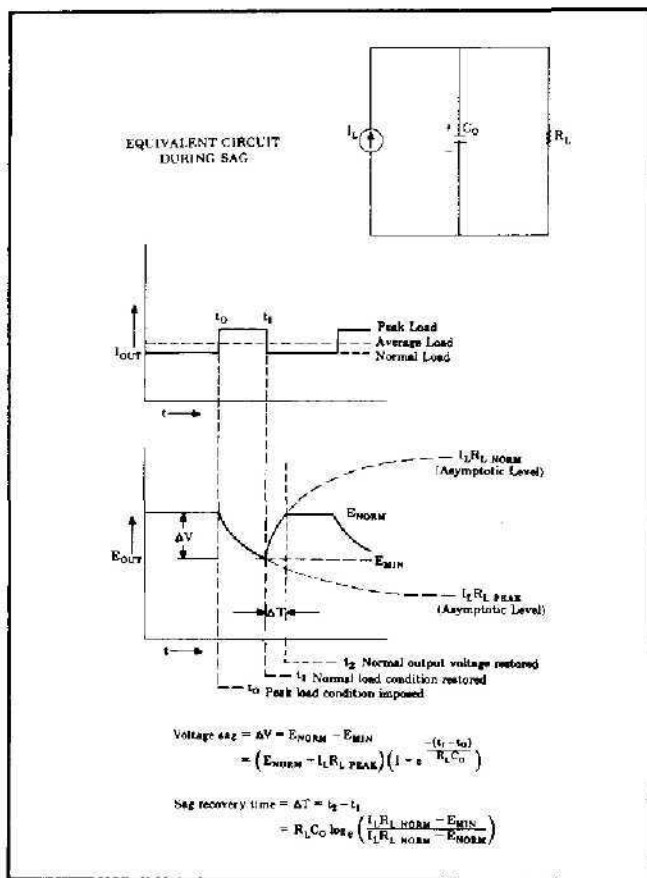

FIGURE 39. Equivalent circuit and output voltage for short term overload.

The first question which must be answered when powering a DC load which would draw a large current during some portion of its operating cycle is whether (1) the power supply need only *withstand* without damage or automatic turn-off the low load resistance corresponding to the peak load condition, or whether (2) the power supply must continue to deliver its full value of regulated output voltage during the peak load interval.

Examples of the first category are DC motors and filaments for large vacuum tubes. While the starting resistance of these loads is very low compared to the normal opening value, it is not necessary that the power supply be able to deliver this peak current—it is necessary that the supply withstand without damage this initial peak load condition and that it continue to operate through the peak load interval until normal load conditions are established. For such loads Constant Voltage/Constant Current or Constant Voltage/Current Limiting supplies rated for the normal (not the peak) load condition are adequate and, in some cases preferable, since the limited output current can provide protection for the load device during the peak load interval. Peak load demands in excess of the current rating of the power supply will not result in damage to the power supply; the output voltage will merely drop to a slightly lower value. Normal output voltage will be restored automatically by the power supply after the peak or transient load condition has passed.

As for the second category, if it is desired to meet a duty cycle requirement similar to that illustrated in Figure 39 while retaining the full value of regulated output voltage during peak load conditions, then a power supply must be selected which has a current rating equal to or greater than the *peak* load requirement. However, if the peak load condition is of relatively short duration, then the stored energy in the power supply output capacitor may prevent an excessive output voltage sag.

Thus for peak loads of either category (1) or (2), it is of interest to know how much the output voltage will drop for a *peak load condition in excess of the power supply current rating*, and how long it will take for the supply to recover to its normal output voltage following the removal of the overload. Figure 39 illustrates the equivalent circuit and output voltage waveform which are characteristic of a power supply experiencing a short term overload. When the overload condition is first imposed, the power supply goes into the current limit mode and is, therefore, equivalent to a constant current generator  $I_L$  feeding the output capacitor  $C_0$  (already charged to  $E_{NORM}$ ) in parallel with the lowered value of load resistance  $R_{L PEAK}$ . Thus the capacitor  $C_0$  begins discharging exponentially toward the final output voltage value which would result if the overload condition were retained, namely  $I_L R_{L PEAK}$ . The amount of voltage sag  $\Delta V$  depends upon the output time constant and the duration of the overload peak load condition; the equation for this voltage sag is given in Figure 39. When the peak load condition is removed,  $R_L$  is restored to its normal value and the supply continues in the current limiting mode, charging the output capacitor on another exponential curve. This time the asymptotic level approached by the exponential curve is  $I_L R_{L NORM}$ . However, this charging action stops when the voltage level has risen back up to the normal level, and the regulator changes from the current limit mode to the normal constant voltage mode. Figure 39 also gives the equation for the time required for this voltage recovery following the removal of the peak load condition.

Thus, the equations of Figure 39 enables one to evaluate whether the voltage sag and recovery time resulting from an overload condition lie within acceptable limits, thus permitting the use of a power supply having a current rating less than the peak load demand. For short term overloads, a quick approximation can be made to determine the amount of voltage sag:

$$\Delta V \cong \frac{(I_P - I_L) \Delta T}{C_0}$$

where:

$\Delta V$  = The voltage sag

$I_P = \frac{E_{NORM}}{R_{L PEAK}}$  = Peak load current demand.

$I_L$  = The current limit or constant current setting.

$C_0$  = The output capacitor (in farads)

$\Delta T$  = Duration of overload condition (in seconds)

This approximation is pessimistic since it assumes that the discharge of the output capacitor proceeds linearly at the rate of  $\frac{I}{C}$ , instead of decaying exponentially.

#### C4. REVERSE CURRENT LOADING

In some applications it is necessary for a power supply to retain its normal regulated output voltage in the presence of reverse current flow during part of the operating cycle of an active load device connected to the power supply. Such situations can arise, for example, in pulse and digital circuitry and in bias supplies for class C amplifiers.

Figure 40A illustrates the nature of this problem. It is assumed that the active load device normally draws a current of 5 amperes, but that during part of its operating cycle it *delivers* a current of 3 amperes. Since the series transistor cannot conduct current in the reverse direction, the reverse current furnished from the load device would charge the output capacitor of the power supply, causing an increase in the output voltage with loss of regulation and possible damage to the output capacitor and other components within the power supply.

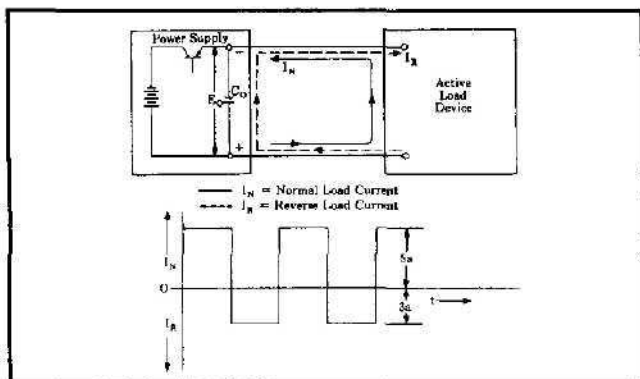

FIGURE 40A. Reverse current loading—problem.

To correct these deficiencies and permit the normal operation of a regulated power supply with loads of this type, it is only necessary to add a shunt or dummy load resistor such as  $R_D$  (Figure 40B), thus shifting the zero bias level with respect to the load current waveform so that the power supply is only required to *deliver* current.

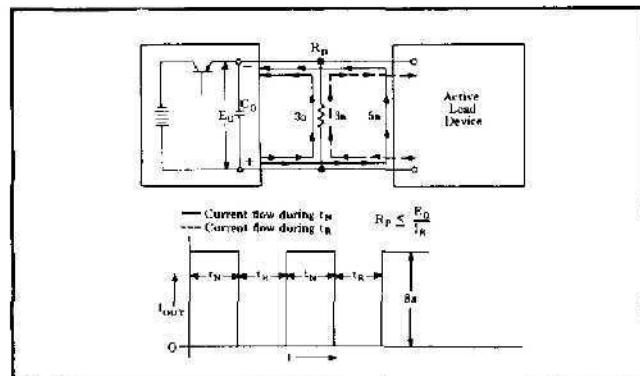

FIGURE 40B. Reverse current loading—solution.

In terms of the numerical example shown in Figure 40, it is necessary to add a resistor  $R_D$  which will draw 3 (or more) amperes at the operating voltage of the power supply. With this resistor added, the power supply output current varies between 0 and 8 amperes rather than between  $-3$  and  $+5$  amperes. During the interval when the load device is *absorbing* current, current flow follows the paths indicated by the solid lines of Figure 40B, whereas when the load device *delivers* current, current flow follows the path indicated by the broken line. Since the power supply is *operating normally* under both conditions, the voltage across the active load device is maintained continuously at the regulated level.

#### C5. CONVERTING A CONSTANT VOLTAGE POWER SUPPLY TO CONSTANT CURRENT OUTPUT

Many, but not all, H-Lab power supplies are capable of constant current operation. Those which are not designed for normal operation as a constant current source can readily be converted, provided the supply has remote programming capability.

As Figure 41 indicates, it is only necessary to add a single external current monitoring resistor to a remote programming constant voltage power supply in order to convert it to constant current operation. (Also any 100 ohm resistor connected inside the supply from  $+S$  to  $+OUT$  should be removed.) Because the proper operation of H-Lab regulator circuitry requires that the negative output and negative sensing terminals be at nearly the same potential, the external current monitoring resistor  $R_M$  must be connected to the negative output terminal, while the constant current load must be connected to the positive output terminal. The front panel control (or remote programming control) is used to determine the voltage  $E$  across the current monitoring resistor  $R_M$ . Since this voltage  $E$  will be held equal to the voltage  $E_p$  across the control resistance by feedback

action, a constant current  $I_T = \frac{E}{R_M}$  will be caused to flow through the current monitoring resistor  $R_M$ . The load current  $I_L$  consists of the current flowing through monitoring resistor plus the programming current  $I_P$  (normally negligibly small compared to  $I_T$ ). Both the current through the monitoring resistor and the programming current are held constant by regulator action; thus the net load current is also constant.

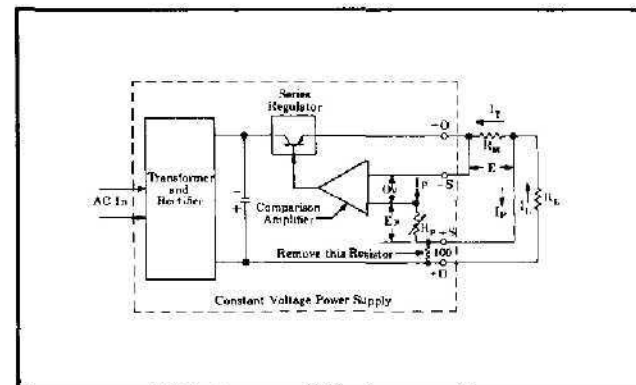

FIGURE 41. Adapting a constant voltage supply to constant current operation.

Since any change in the value of the resistance  $R_M$  will result in a change in the load current, the current monitoring resistor should have a low temperature coefficient and should be operated at less than 1/10 (or even 1/100) of its power rating. This, plus the restriction that the total  $I_R$  drop across  $R_M$  and  $R_L$  in series cannot exceed the voltage rating of the power supply, means that  $R_M$  will be selected so that its  $I_R$  drop will be of the order of 1 volt, depending upon the constant current value required.

The constant current performance of a supply connected in the method shown in Figure 41 can be predicted by dividing the constant voltage specification by the value of  $R_M$ , and then adding on a percentage basis any change in the value of  $R_M$  due to temperature effects. The lowest constant current output level is limited to the programming current  $I_P$ , typically 5 milliamps.

More details on this method of adapting constant voltage power supplies to constant current applications, including all design details necessary for the proper selection of  $R_M$ , are discussed in H-Lab Tech Letter #5, available free on request.

#### C6. AUTOMATIC BATTERY CHARGING

Automatic battery charging is readily accomplished using any H-Lab CV/CC or CV/CL power supply with automatic crossover. For such applications, current limiting supplies differ from constant current supplies only in the accuracy of the charge rate setting; in both cases, the constant voltage limit can be set with sufficient accuracy to avoid overcharging or "gassing".

Operation is extremely simple; one need only short the output terminals of the supply and set the current limit or constant current control to the desired charge rate (amperes = coulombs/second). Next, the output terminals are left open and the voltage control is set for the final value of voltage to which it is desired to charge the battery. Finally, the battery, regardless of its state of charge, is connected directly across the output terminals of the supply. Charging action is completely automatic, and it is not necessary for an attendant to monitor the battery during charging or to readjust any controls on the power supply.

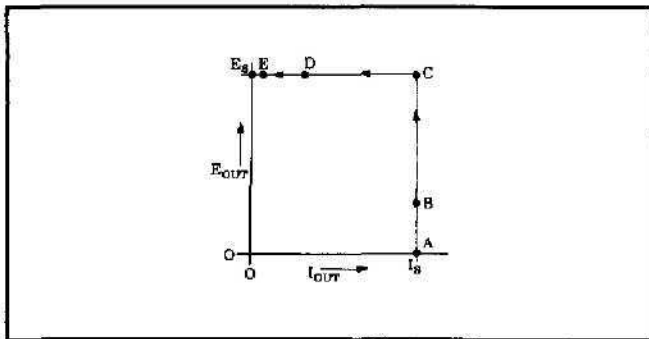

FIGURE 42. Operating locus of a CV/CC or CV/CL power supply used for battery charging.

A completely uncharged battery will in most cases appear as something approximating a short circuit being fed by a constant current  $I_S$ , the front panel current control setting. This is shown as operating point A in

Figure 42. As the charging action proceeds, the voltage across the battery "increases" with the current through the battery still remaining constant (Point B). When the charging action nears completion, the voltage across the battery achieves a level corresponding to point C, and the power supply automatically transfers to constant voltage operation, reducing the charging current to whatever value is necessary to maintain the battery voltage at the value  $E_S$ , the front panel voltage control setting. The power supply proceeds through operating point D to point E, the full charge point. Notice that this final operating point has associated with it some small value of current which will exactly offset the leakage current within the battery. Thus the battery remains in its fully charged condition, with a trickle charge being provided until the battery is removed from the power supply terminals and placed into service.

In some battery charging applications, the internal resistance of the battery is such that its  $I_R$  drop (not the current limit setting of the power supply) limits the current value of the charging current. This has the effect of decreasing the charge rate as the battery voltage is increased, but the final voltage to which the battery charges remains the same, and automatic unattended battery charging is still accomplished in a fool-proof fashion.

Automatic battery discharging can also be accomplished using H-Lab CV/CC and CV/CL power supplies. Contact the factory for further information.

#### C7. OPERATION AT ELEVATED TEMPERATURES

Nearly all H-Lab power supplies are rated for operation at 0°C to 50°C (32°F to 122°F) ambient temperature without degradation of output rating or any other specifications. Care must be taken, however, when rack mounting power supplies closely together or in proximity with other heat-producing units that the power supplies are not surrounded by an actual air temperature greater than 50°C. An unventilated rack full of equipment may surround a power supply with an effective ambient of 55°C or 60°C even though the room temperature is kept at or below 40°C. In such cases, ventilation must be provided to insure that the temperature immediately surrounding the power supply is not in excess of 50°C.

An exact measurement of the temperature of the air separating two adjacent instruments mounted in a rack can be difficult if not impossible. However, devices are available which permit easy measurement of the heat sink temperature of a power supply while it and adjacent pieces of equipment are operating in the rack. Harrison Laboratories will furnish on request an indication of the maximum heat sink temperature which should be allowed on any supply, and sufficient ventilation can then be added until the heat sink temperature is safely below this limit.

Although rated for a maximum of 50°C ambient, most H-Lab power supplies can be operated at somewhat higher temperatures under certain circumstances. Further information concerning any necessary derating can be furnished on request and depends on the model number, the input line voltage, and the output voltage and current.

## D. POWER SUPPLY SPECIFICATIONS—DEFINITION AND MEASUREMENT

### D1. CONSTANT VOLTAGE POWER SUPPLY MEASUREMENTS

#### a. Test Setup—General Comments.

Figure 43 illustrates a setup suitable for the measurement of the six most important operating specifications of a constant voltage power supply—line regulation, load regulation, ripple and noise, transient recovery time, stability, and temperature coefficient.

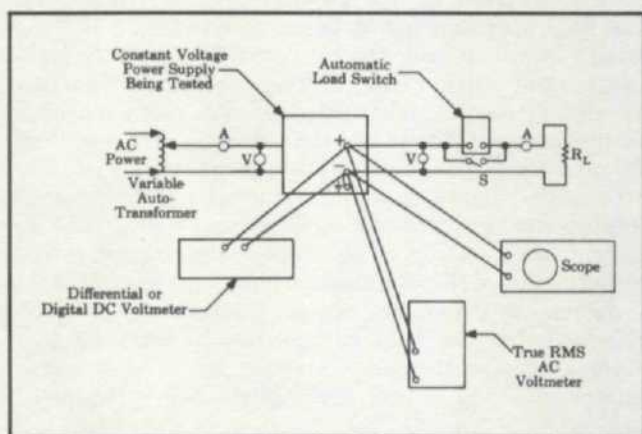

FIGURE 43. Constant voltage measurement set-up

MEASURING INSTRUMENT	NECESSARY CHARACTERISTICS	SUITABLE MODEL NUMBER
Oscilloscope	Minimum bandwidth 100Kc, vertical sensitivity 1 millivolt per centimeter minimum, 100 $\mu$ volts per centimeter preferred, differential input preferred.	HP140A with 1400A vertical plug-in
Differential or Digital DC Voltmeter	Resolution—1 millivolt or better at voltages up to 300 volts	HP740A Fluke 825A Dymec 2401B
True RMS Voltmeter	Sensitivity 100 $\mu$ volts full scale. Crest factor 10:1	HP3400A

The automatic load switch shown in Figure 43 is used to periodically interrupt the load when measuring transient recovery time. Full details of a suitable load switch and the method employing it are given later, in Section D1.e "Transient Recovery Time."

#### PRECAUTIONS:

##### (1) Measure Performance at Front or Rear Terminals.

Before attaching the load and monitoring devices shown in Figure 43, it is necessary to determine (in the case of power supplies having both front and rear terminals) whether the supply is connected for front or rear terminal sensing, since both the load and monitoring devices must be connected to the same pair of output terminals to which the feedback amplifier within the power supply is connected. In the case of small laboratory supplies which feature Automatic Error Sensing, performance measurements can be made at either the front or rear output terminals but are normally accomplished at the rear terminals.

##### (2) Connect Leads to Power Supply Terminals Properly.

Casual clip lead connections will inevitably result in serious measurement errors—in most cases placing the measurement results beyond the power supply's specifications even though the power supply is operating perfectly. The load and monitoring leads must be connected to the power supply terminals *exactly* as shown in Figure 44. If performance measurements are made at the front terminals (Figure 44A) the load should be plugged into the front of the terminal at (B) while the monitoring device is connected to a small lead or bus wire inserted through the hole in the neck of the binding post at (A). If performance is being measured at the rear barrier strip (Figure 44B), the load should be connected to the plus and minus sensing terminals; in this way the monitoring device sees the same performance as the feedback amplifier within the power supply which is sensing and correcting the output.

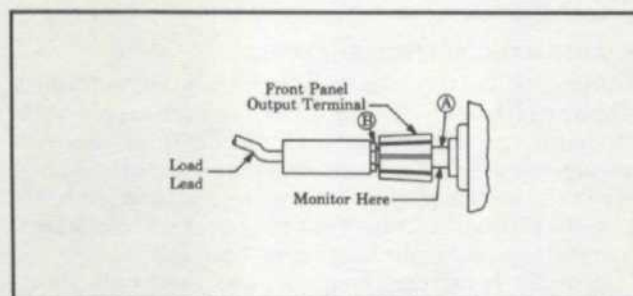

FIGURE 44A. Proper method of connecting monitoring and load leads to front panel power supply terminals.

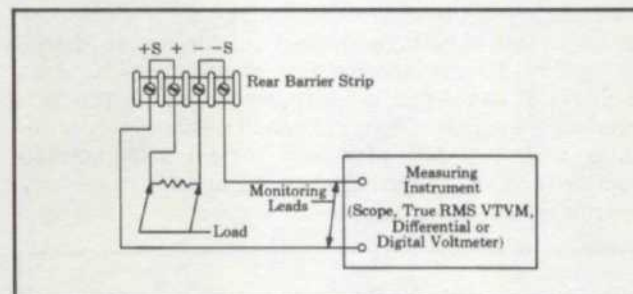

FIGURE 44B. Proper method of connecting monitoring and load leads to rear panel power supply terminals.

The importance of proper connection of load and monitoring leads to the power supply output terminals cannot be overemphasized, since the most common errors associated with the measurement of power supply performance result from improper connection to the output terminals. Failure to connect the monitoring instrument to the proper points shown in Figures 44A and 44B will result in the measurement not of the power supply characteristics, but of the power supply plus the resistance of the leads between its output terminals and the point of connection. Even connecting the load by means of clip leads to the power supply terminals and then connecting the monitoring instrument by means of clip leads fastened to the load clip leads can result in

a serious measurement error. Remember that the power supply being measured probably has an output impedance of less than 1 milliohm, and the contact resistance between clip leads and power supply terminals will in most cases be considerably greater than the specified output impedance of the power supply.

**(3) Use Separate Leads to All Measuring Instruments.**

All measurement instruments (oscilloscope, AC voltmeter, differential or digital voltmeter) must be connected *directly* by separate pairs of leads to the monitoring points indicated in Figure 44A and 44B. This is necessary in order to avoid the rather subtle mutual coupling effects which may occur between measuring instruments unless all are returned to the low impedance terminals of the power supply. Twisted pairs (in some cases shielded two-conductor cable will be necessary) should be used to avoid pickup on the measuring leads.

**(4) Use an Adequate Load Resistor.**

The resistance and wattage rating of the load resistor depends upon the output voltage and current of the supply; in general, a load resistor should be selected which permits operation of the supply at its maximum rated output voltage and current. Continuously variable load boxes manufactured by Rex Rheostat are excellent for this purpose and may be bought in a large variety of resistance and wattage ratings. When measuring the transient recovery time of power supplies requiring low resistance loads, it may be necessary to use non-inductive loads so that the  $L/R$  time constant of the load will not be greater than the inherent recovery time of the power supply, thus impeding the measured transient recovery performance.

**(5) Check Current Limit Control Setting.**

When measuring the constant voltage performance specifications, the constant current or current limit control must be set well above the maximum output current which the supply will draw, since the onset of constant current or current limiting action can cause a drop in output voltage, increased ripple, and other performance changes not properly ascribed to the constant voltage operation of the supply.

**(6) Check Setup for Pickup and Ground Loop Effects.**

Care must be taken that the measured performance is not unduly influenced by the presence of pickup on the measuring leads or by power line frequency components introduced by ground loop paths. Two quick checks should be made to see if the measurement setup is free of extraneous signals:

- (a) Turn off the power supply and observe whether any signal is observable on the face of the CRT (with the scope connected between +S and -S).
- (b) Instead of connecting the oscilloscope leads separately to the positive and negative sensing terminals of the supply, connect both leads to either the positive or the negative sensing terminal, whichever is grounded to chassis.

Signals observable on the face of the CRT as a result of either of these tests are indicative of shortcomings in the measurement setup. The most likely causes of these defects and proper corrective measures are discussed further in Section D1.d, "Ripple and Noise."

**(7) Connect AC Voltmeter Properly.**

It is important that the AC voltmeter be connected as closely as possible to the input AC terminals of the power supply so that its indication will be a valid measurement of the power supply input, without any error introduced by the IR drop present in the leads connecting the power supply input to the AC line voltage source.

**(8) Use an Auto-Transformer of Adequate Current Rating.**

If this precaution is not followed, the input AC voltage presented at the power supply may be severely distorted, and the rectifying and regulating circuits within the power supply may be caused to operate improperly. Since the largest H-Lab single phase power supply at this writing draws a little less than 20 amperes from the AC input, it is recommended that a general purpose test set-up use a variable transformer having a current rating of 20 or 25 amperes.

**(9) Do Not Use an AC Input Line Regulator**

Such regulators tend to increase the impedance of the AC line in a resonant fashion, and can cause malfunctioning of the power supply, particularly if the supply employs an SCR or switching type regulator or preregulator. Moreover, since the control action of line voltage regulators tends to be accompanied by a change in the waveshape of the AC output, their advantage in keeping the input to a power supply constant is practically nil, since such waveshape changes are nearly as effective in causing output voltage changes of the power supply as the original uncorrected line voltage change.

Further precautions necessary to the proper measurement of power supply specifications are given as required in the following sections, which discuss the use of the constant voltage measurement setup of Figure 43 in measuring the six most important power supply specifications.

**b. CV Line Regulation.**

Definition: The change,  $\Delta E_{out}$ , in the static value of DC output voltage resulting from a change in AC input voltage over the specified range from low line (usually 105 volts) to high line (usually 125 volts), or from high line to low line.

Actual measurement is accomplished by turning the variable autotransformer (Figure 43) through the specified range from low line to high line and noting the change in the reading of the digital voltmeter or differential voltmeter connected to the output terminals of the supply. The power supply will perform within its line regulation specification at any rated output voltage combined with any rated output current; the most severe test normally involves measuring line regulation at maximum output voltage combined with maximum output current.

Notice that for practically all H-Lab power supplies the line regulation specification is not prefixed by “±”, nor is the line voltage input change specified “115 volts ± 10%.” Thus, H-Lab’s line regulation specification sets a limit on the *total* excursion of the output voltage resulting from the *total* input AC change from low line to high line, thereby allowing only one-half the output deviation of a “±” specification.

### c. CV Load Regulation

Definition: The change  $\Delta E_{out}$  in the static value of DC output voltage resulting from a change in load resistance from open circuit to a value which yields maximum rated output current (or vice versa).

Load regulation is measured by throwing the switch S in Figure 43 and noting the resulting static change  $\Delta E_{out}$  in the output voltage on the digital voltmeter or differential voltmeter connected to the output terminals. The power supply will perform within its load regulation specification at any rated output voltage combined with any rated input line voltage.

### d. CV Ripple and Noise

Definition: The residual AC voltage which is superimposed on the DC output of a regulated power supply, usually specified and measured in terms of its RMS value.

Ripple and noise measurement of an H-Lab constant voltage regulated DC power supply can be made at any input AC line voltage combined with any DC output and load current within rating.

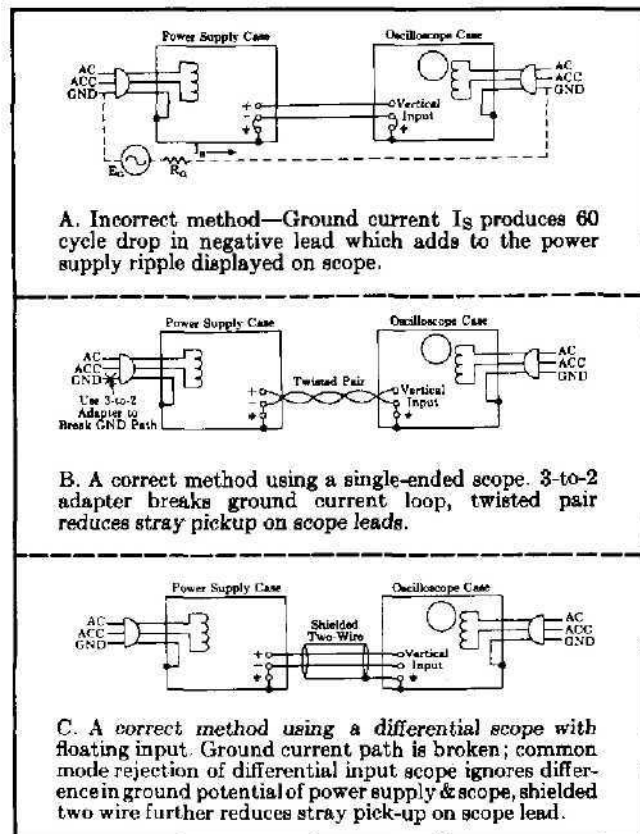

FIGURE 45. Measurement of ripple and noise output of a CV power supply.

Figure 45A shows an incorrect method of measuring ripple and noise. Note that a continuous ground loop exists from the third wire of the input power cord of the power supply to the third wire of the input power cord of the oscilloscope via the grounded power supply case, the wire between the negative output terminal of the power supply and the vertical input of the scope, and the grounded scope case. Any ground current circulating in this loop as a result of the difference in potential  $E_G$  between the two ground points causes an IR drop which is in series with the scope input. This IR drop, normally having a 60 cycle line frequency fundamental, plus any pickup on the untwisted or unshielded leads interconnecting the power supply and scope appears on the face of the CRT. The magnitude of this resulting noise signal can easily be much greater than the true ripple developed between the plus and minus output terminals of the power supply, and can completely invalidate the measurement.

The same ground current and pickup problems can exist if an RMS voltmeter is substituted in place of the oscilloscope in Figure 45A. However, the oscilloscope display, unlike the true RMS meter reading, tells the observer immediately *whether the fundamental period of the signal displayed is 8.3 milliseconds (1/120 cps) or 16.7 milliseconds (1/60 cps)*. Since the fundamental ripple frequency present on the output of an H-Lab supply is 120 cps (due to full-wave rectification), an oscilloscope display showing a 120 cps fundamental component is indicative of a “clean” measurement setup, while the presence of a 60 cps fundamental usually means that an improved setup will result in a more accurate (and lower) value of measured ripple.

Figure 45B shows a correct method of measuring the output ripple of a constant voltage power supply using a single-ended scope. The ground loop path is broken with a 3 to 2 adapter in series with the power supply’s AC line plug. Notice, however, that the power supply case is still connected to ground via the power supply output terminals, the leads connecting these terminals to the scope terminals, the scope case and the third wire of the power supply cord.

Either a twisted pair or (preferably) a shielded two-wire cable should be used to connect the output terminals of the power supply to the vertical input terminals of the scope. When using a twisted pair, care must be taken that one of the two wires is connected both to the grounded terminal of the power supply and the grounded input terminal of the oscilloscope. When using shielded two-wire, it is essential for the shield to be connected to ground at *one end only* so that no ground current will flow through this shield, thus inducing a noise signal in the shielded leads.

In most cases, the single-ended scope method of Figure 45B will be adequate to eliminate non-real components of ripple and noise so that a satisfactory measurement may be obtained. However, in more stubborn cases, or in measurement situations where it is essential that both the power supply case and the oscilloscope case be connected to ground (e.g. if both are rack-mounted), it may be necessary to use a differential scope with floating input as shown in Figure 45C. Because of

its common mode rejection, such an oscilloscope displays only the difference in signal between its two vertical input terminals, thus ignoring the effects of any common mode signal introduced because of the difference in the AC potential between the power supply case and scope case. Before using a differential input scope in this manner, however, it is imperative that the common mode rejection capability of the scope be verified by shorting together its two input leads at the power supply and observing the trace on the CRT. If this trace is a straight line, the scope is properly ignoring any common mode signal present. If this trace is not a straight line, then the scope is not rejecting the ground signal and must be realigned in accordance with the manufacturer's instructions until proper common mode rejection is attained.

In many cases a proper measurement setup will reveal that the peak-to-peak ripple on the output of an H-Lab power supply will be less than the RMS value specified. Since the RMS value of any waveform is less than its peak-to-peak value, such a measurement result immediately proves that the power supply is meeting its ripple specification and eliminates any need for an RMS measurement.

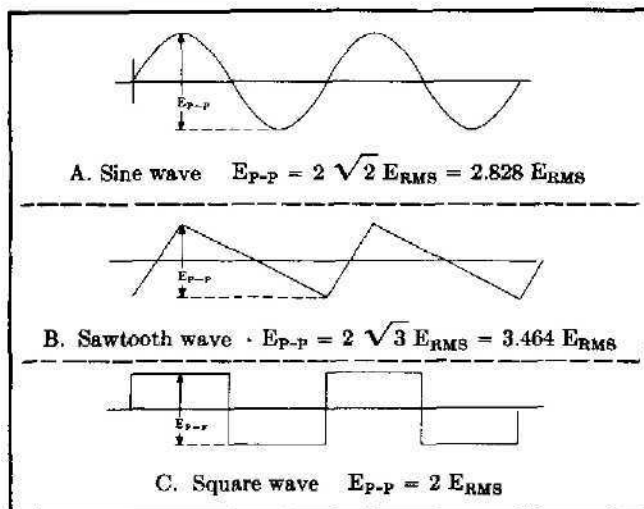

FIGURE 46. Three possible ripple wave shapes.

Figure 46 shows the relationship between the peak-to-peak and RMS values of three common waveforms. The output ripple of a DC power supply usually does not approximate the sine wave of Figure 46A; in many cases the output ripple has a waveshape which very closely approximates the sawtooth of Figure 46B. In this case, the RMS ripple is  $\frac{1}{3.464}$  of the peak-to-peak value displayed on the oscilloscope. The square wave is included in Figure 46 because this waveshape has the highest possible ratio of RMS to peak-to-peak. Thus, the RMS ripple and noise present on the output terminals of a power supply cannot be greater than  $\frac{1}{2}$  the peak-to-peak value measured on the oscilloscope. In most cases the ripple waveshape present on the output terminals of H-Lab power supplies is such that the RMS value is between  $\frac{1}{3}$  and  $\frac{1}{4}$  of the peak-to-peak value.

## e. Transient Recovery Time

Definition: The time X for output voltage recovery to within Y millivolts of the nominal output voltage following a Z amp step change in load current—where:

Y is specified separately for each model but is generally of the same order as the load regulation specification.

The nominal output voltage is defined as the DC level half way between the static output voltage before and after the imposed load change, and

Z is the specified load current change, normally equal to the full load current rating of the supply.

Transient recovery time may be measured at any input line voltage combined with any output voltage and load current within rating.

If a step change in load current is imposed on the output of a power supply, the output voltage will exhibit a transient of the type shown in Figure 47. The output impedance of any power supply eventually rises at high frequencies, giving rise to an equivalent output inductance; if the load current is switched rapidly enough so that the high frequencies associated with the leading edge of the step change can react with this effective output inductance, there will occur on the output terminals of any power supply a spike of amplitude  $L di/dt$ , where L is the effective output inductance of the supply at high frequencies, and  $di/dt$  is the rise time of the load current change imposed. For most H-Lab power supplies of moderate or high output rating, L is of the order of 0.16 microhenries (1 ohm at 1 megacycle), whereas for small power supplies, the output inductance may be as high as 0.3 microhenries.

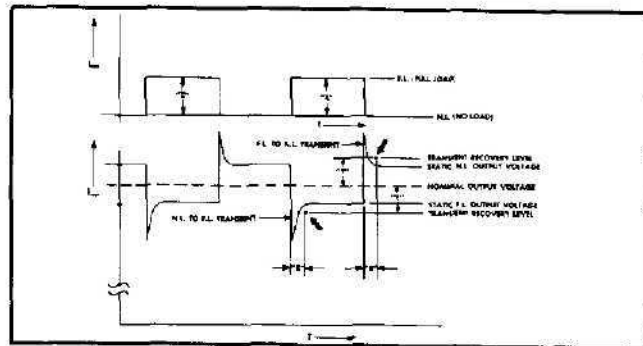

FIGURE 47. Transient recovery of a constant voltage power supply.

Thus, it is not possible to specify the amplitude of an output voltage spike caused by a load current change unless the rise time of the load change is first established. A power supply with an effective output inductance of 0.16 microhenries will exhibit a load transient spike of about 0.16 volts if the load is switched with a rise time of 1 amp/ $\mu$ sec, but the spike amplitude will be only 160  $\mu$ v if the load is switched at 1 amp/millisecond. In this latter case the output spike would not be evident, since it would be small compared to the static change in output voltage associated with the full load change.

While an oscilloscope with a bandwidth of the order of 100 Kc is adequate to observe and measure the transient recovery time of a power supply, the spike amplitude for load switching times of less than 1 microsecond cannot be accurately determined, unless a very wide band scope is used.

Of all power supply specifications, transient recovery time is subject to the widest variation in definition, and is not defined at all by some power supply manufacturers. It is important to notice that a simple statement that a power supply has a transient recovery time of "50 microseconds" is incomplete and conveys no information. Such a specification leaves to the imagination whether the power supply will recover during the 50  $\mu$ second interval to within 37% (1/e) of its initial value, or to within 10%, or "all the way." A definition based on 37% or 1/e recovery is not useful since the transient recovery waveshape, being dependent upon the nature of a closed feedback loop, is in general not exponential. Nor is a definition based on 90% decay of the transient useful, since as mentioned previously, the amplitude of the transient varies with the rise time of the load current change imposed. Finally, one cannot define recovery "all the way" since no transient ever completely dies away, and the time measured would be dependent upon the setting of the oscilloscope vertical gain control.

Since the falling portion of the transient remains reasonably constant in spite of wide variations in the spike amplitude and the speed of the load change causing it, Harrison Laboratories has chosen to define transient recovery time in terms of recovery to a certain voltage level. For ease in oscilloscope measurement, this voltage level is referenced to a nominal output voltage half way between no load and full load.

Reasonable care must be taken in switching the load resistance on and off. A hand-operated switch in series with the load is not adequate, since the resulting one-shot displays are difficult to observe on most oscilloscopes, and the arc energy occurring during switching action completely masks the display with a noise burst. Transistor load switching devices are expensive if reasonably rapid load current changes are to be achieved.

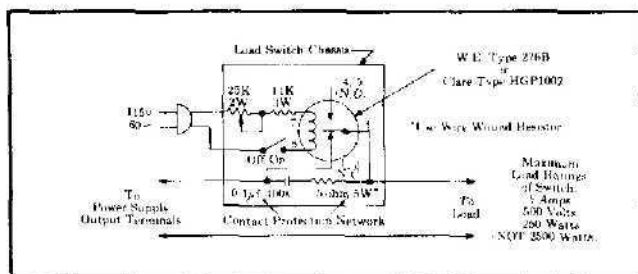

FIGURE 48. Automatic load switch for measuring transient recovery time.

Harrison Laboratories employs a mercury-wetted relay, using the load switching circuit of Figure 48. When this load switch is connected to a 60 cycle AC input, the mercury wetted relay will open and close 60 times per second. Adjustment of the 25K control permits adjustment of the duty cycle of the load current switching and reduction in jitter of the oscilloscope display.

The maximum load ratings listed in Figure 48 must be observed in order to preserve the mercury-wetted relay contacts. Switching of larger load currents can be accomplished with mercury pool relays; with this technique fast rise times can still be obtained, but the large inertia of mercury pool relays limits the maximum

repetition rate of load switching and makes the clear display of the transient recovery characteristic on an oscilloscope more difficult.

The scope is set up for internal sync and the presentation is locked on either the positive or the negative load transient spike. The vertical input of the oscilloscope should be set for AC coupling so that small DC level changes in the output voltage of the power supply will not cause the display to shift. The sweep rate is first set so that several full cycles of no load to full load and full load to no load operation are displayed. The vertical centering control on the scope is adjusted so that the tail ends of the no load and full load waveforms are symmetrically displaced about the horizontal center line of the oscilloscope. This center line thus represents the nominal output voltage defined in the specification. The horizontal positioning control is set so that the trace is known to start at the point which is coincident with a major graticule division; this point is then representative of time zero. The sweep rate is increased so that a single transient spike can be examined in detail. The sync controls are adjusted separately for the positive and negative going transients so that not only the recovery waveshape but also as much as possible of the rise time of the transient is displayed. Starting from the major graticule division representative of zero time, count to the right Y microseconds (obtained from the specification sheet for the power supply being measured); starting from the horizontal center line, count vertically X millivolts (again obtained from the specification sheet). The intersection of the Y  $\mu$ sec and X mv line on the graticule corresponds to the specification points shown with large arrows in Figure 47; the transient recovery waveform must lie inside this point.

## f. CV Stability

Definition: The change in output voltage for the first eight hours following a 30 minute warm-up period. During the interval of measurement all parameters, such as load resistance, ambient temperature, and input line voltage are held constant.

This measurement is made by monitoring the output of the power supply on a differential voltmeter or digital voltmeter over the stated measurement interval; a strip chart recorder can be used to provide a permanent record. A thermometer should be placed near the supply to verify that the ambient temperature remains constant during the period of measurement. The supply should be put in a location immune from stray air currents (open doors or windows, air conditioning vents); if possible, the supply should be placed in an oven which is held at a constant temperature. Care must be taken that the measuring instrument has a stability over the eight hour interval which is at least an order of magnitude better than the stability specification of the power supply being measured. Typically, a supply may drift less over the eight hour measurement interval than during the 1/2 hour warm-up period.

Stability measurements can be made while the supply is remotely programmed with a fixed wire-wound resistor, thus avoiding accidental changes in the front panel setting due to mechanical vibration or "knob-twiddling"

### g. CV Temperature Coefficient

Definition: The change in output voltage per degree Centigrade change in the ambient temperature under conditions of constant input AC line voltage, output voltage setting, and load resistance.

The temperature coefficient of a power supply is measured by placing the power supply in an oven and varying it over any temperature span within its rating. (Most H-Lab power supplies are rated for operation from 0°C to 50°C.) The power supply must be allowed to thermally stabilize for a sufficient period of time at each temperature of measurement.

The temperature coefficient specified is the maximum temperature-dependent output voltage change which will result over any 5°C interval. The differential voltmeter or digital voltmeter used to measure the output voltage change of the supply should be placed outside the oven and should have a long term stability adequate to insure that its drift will not affect the overall measurement accuracy.

### h. Other Constant Voltage Specifications

The output impedance of a power supply is normally not measured, since the measurement of transient recovery time reveals both the static and dynamic output characteristics with just *one* measurement. The output impedance of a power supply is commonly measured only in those cases where the exact value at a particular frequency is of engineering importance. Complete information on proper methods of measuring output impedance is available from your nearest H-Lab/HP sales office—ask for H-Lab Tech Letter 4, "Measurement of Output Impedance of a Constant Voltage Power Supply."

Proper methods of measuring any of the other operating specifications for constant voltage power supplies can also be obtained by contacting your local H-Lab/HP sales office or the factory.

## D2. CONSTANT CURRENT POWER SUPPLY MEASUREMENTS

### a. Test Setup—General Comments

For the most part the instruments, methods, and precautions necessary for the proper measurement of constant current power supply characteristics are identical to those already described for the measurement of constant voltage power supplies. As Figure 49 shows, there are only two major differences which distinguish the constant current measurement setup from the constant voltage measurement setup.

1. The load switch is connected in parallel rather than in series with the power supply load, since the power supply performance will be checked between short circuit and full load rather than open circuit and full load.
2. A current monitoring resistor is inserted between the output of the power supply and the load. To simplify grounding problems, one end of this monitoring resistor should be connected to the same output terminal of the power supply which will be shorted to ground. All constant current measurements are made in terms of the change in voltage across this resistor; the current performance is calculated by dividing these voltage changes by the ohmic value of  $R_1$ .

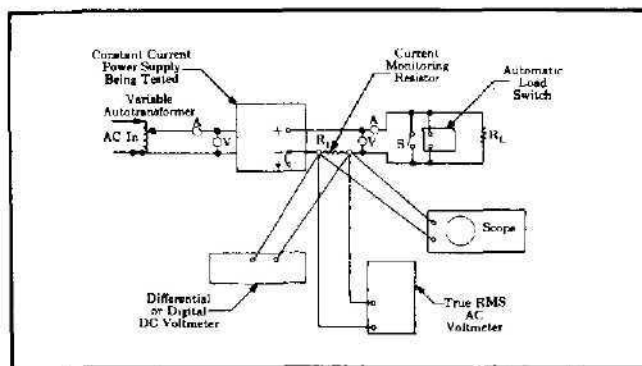

FIGURE 49. Constant current measurement setup

Many of the precautions listed in Section D1 with reference to a constant voltage measurement setup are equally applicable to a constant current setup. However, a list is provided below of other precautions peculiar to a constant measurement setup. Many of these precautions concern the series monitoring resistor; since all constant current performance specs will be checked by measuring the voltage drop across  $R_1$ , particular care must be given to the proper selection and connection of this element.

### PRECAUTIONS:

#### (1) $R_1$ Must be Treated as a Four-Terminal Device.

In the manner of a meter shunt, the load current must be fed from the extremes of the wire leading to this resistor, while the voltage monitoring terminals connected to the three measuring instruments should be located as close as possible to the resistance portion itself, as shown in Figure 50.

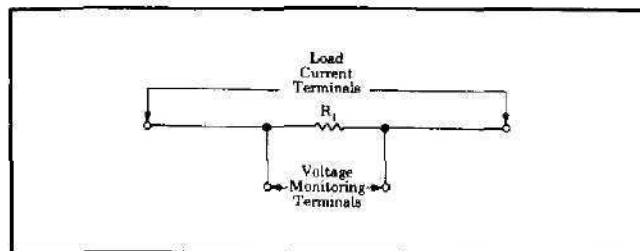

FIGURE 50. Four terminal nature of current monitoring resistor.

#### (2) Use Precision, Low T.C. Monitoring Resistor.

Resistor  $R_1$  should be a precision ammeter shunt or a wire wound resistor (20ppm/°C or better) and should be operated at a power less than 1/10 (preferably 1/100) of its rating so that its surface temperature will not be high compared with ambient and therefore subject to slow thermal fluctuations which cause similar changes in the resistance value itself.

A crude "thumb rule" will suggest the order of magnitude of the measurement problems which can be encountered if adequate power derating is not applied to the current monitoring resistor. With typical wire-wound power resistors, operation at 10% of power rating will be accompanied by approximately a 50°C temperature rise above ambient at the surface of the resistor; the

“bobble,” or slow variation in this surface temperature, will amount to about 20% of the rise above ambient—in this case a “bobble” of about 10°C (peak-to-peak). Using a 20 ppm resistor, this 10°C variation will cause roughly a .02% variation in the measured current, even though the monitoring resistor is being operated at only 1/10 of its power rating!

**(3) Keep Temperature of  $R_I$  Constant.**

The resistor  $R_I$  should be located and protected so that it will not be subjected to stray air currents (open doors or windows, air conditioning vents), since these will introduce a change in resistance value which may mar the measurements, particularly stability and temperature coefficient.

**(4) Check Voltage Control Setting.**

When measuring the constant current performance specifications, the power supply's voltage control must be set above the maximum output voltage which the supply will deliver since voltage limiting action will cause a drop in output current, increased ripple current, and other performance changes not properly ascribed to the constant current operation of the supply.

**(5) Do Not Connect DC Voltmeter Directly Across Power Supply Output Terminals.**

Note that in Figure 49 the DC voltmeter used to monitor the output of the power supply is connected *outside* the current monitoring resistor. Thus, the true output voltage of the supply is obtained by adding this voltmeter reading to the voltage across the current monitoring resistor. If the voltmeter were placed on the left side of the current monitoring resistor of Figure 49, a change in output voltage of the constant current supply would result in a change in current through the voltmeter input resistance. As can be seen from Figure 51, if we assume a power supply with a perfectly constant current output, this change in current through the incorrectly connected voltmeter will necessarily be accompanied by an equal magnitude change in current through the load and the current monitoring resistor, thus degrading the measured constant current performance. Of course, if a sufficiently high resistance DC voltmeter is used, this precaution need not be observed, since the voltmeter input current will be small compared to the current change being measured.

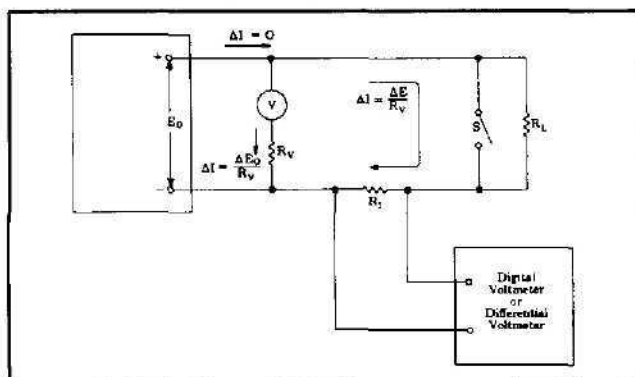

FIGURE 51. Measurement error due to voltmeter across output terminals of constant current power supply.

Other precautions associated with the proper measurement of constant current power supply specifications are given in the following sections as required; these sections discuss the use of the constant current measurement setup of Figure 49 for measuring the most important constant current power supply specifications.

**b. CC Line Regulation**

Definition: The change,  $\Delta I_{OCT}$  in the static value of DC output current resulting from a change in AC input voltage over the specified range from low line (usually 105 volts) to high line (usually 125 volts), or from high line to low line.

Measurement is accomplished by turning the variable autotransformer of Figure 49 through the specified input voltage range and noting the change in the reading on a digital voltmeter or differential voltmeter connected across the current monitoring resistor; this change, when divided by the value of the current monitoring resistor, yields the change in output current. The power supply will perform within its line regulation specification at any rated output current combined with any rated output voltage.

**c. CC Load Regulation**

Definition: The change,  $\Delta I_{OUT}$  in the static value of the DC output current resulting from a change in load resistance from short circuit to a value which yields maximum rated output voltage.

Load regulation is measured by throwing the switch S in Figure 49 and noting the resulting static change on the digital voltmeter or differential voltmeter connected across the current monitoring resistor. The power supply will perform within its load regulation specifications at any rated output current combined with any rated line voltage.

**d. CC Ripple and Noise**

Definition: The residual AC current which is superimposed on the DC output current of a regulated supply, usually specified and measured in terms of its RMS value.

The peak-to-peak voltage measured on the oscilloscope across  $R_I$  is divided by  $R_I$  to obtain the peak-to-peak ripple current. This value is then divided by a suitable conversion factor to obtain RMS ripple. In cases where the oscilloscope measurement yields a marginal result, resort should be made to a true RMS voltmeter reading across  $R_I$  after first utilizing the oscilloscope to insure that the input waveform to the RMS voltmeter has a 120 cycle fundamental component and is free of extraneous signals not coming from the power supply output.

Most of the comments pertaining to the ground loop and pick-up problems associated with constant voltage ripple and noise measurement also apply to the measurement of constant current ripple and noise. Figure 52 illustrates the most important precautions to be observed when measuring the ripple of a constant current supply. The presence of a 120 cycle waveform on the oscilloscope is normally indicative of a correct measurement method. A waveshape having 60 cycles as its fundamental component is typically associated with an incorrect measurement setup. As before, the basic measuring instrument

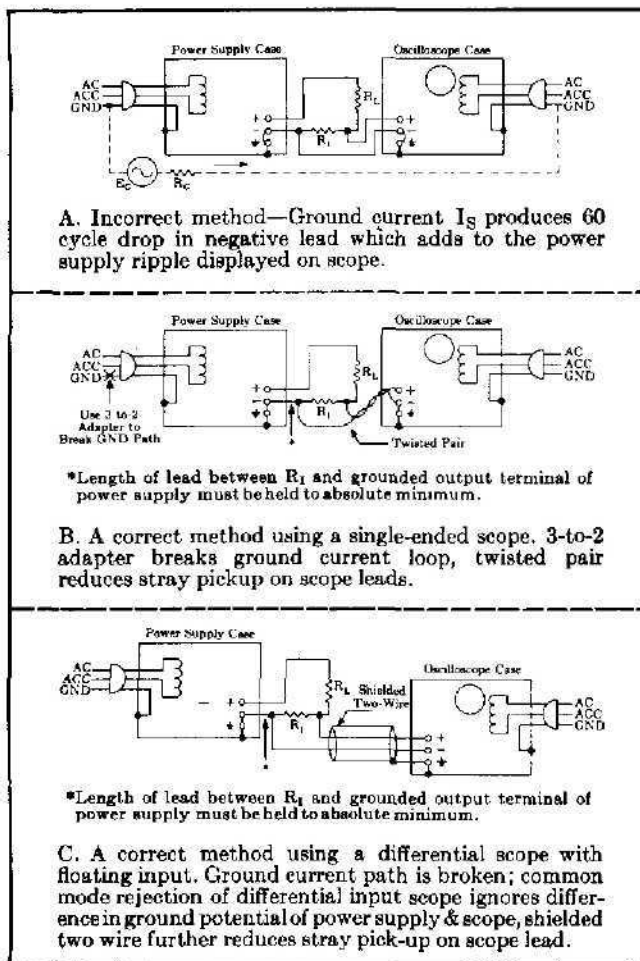

FIGURE 52. Measurement of ripple and noise output of a CC power supply.

is an oscilloscope. The peak-to-peak/RMS conversion factors suggested by Figure 46, and comments in the previous sections of this Application Manual dealing with constant voltage pick-up and ground loop effects,

as well as the section dealing with the measurement of constant voltage ripple and noise, apply in full.

#### e. CC Stability

**Definition:** The change in output current for the first 8 hours following a 30 minute warm-up period. During the interval of measurement all parameters such as load resistance, ambient temperature, and input line voltage are held constant.

The stability of a power supply in constant current operation must be measured while holding the temperature of the power supply and the current monitoring resistor  $R_1$  as constant as possible. Variations of the voltage across this current monitoring resistor over the specified 8-hour interval are measured on the digital or differential voltmeter and may be recorded on a strip chart recorder. Since such voltage measurements are generally being made at a rather low level, it is important to check that the stability of the measuring instruments is adequate to insure an accurate check on the power supply performance.

#### f. CC Temperature Coefficient

**Definition:** The change in output current per degree Centigrade change in the ambient temperature under conditions of constant input AC line voltage, output current setting, and load resistance.

The constant current power supply must be placed in an oven and operated over any temperature span within the power supply rating. The current monitoring resistor  $R_1$  should not be placed in the oven, but must be held at a constant temperature while this measurement is made.

#### g. Other Constant Current Specifications

The measurement of transient recovery time, output impedance, and other performance specifications is less often required in the case of constant current power supplies. Complete information on proper methods of measuring any other constant current specifications beyond those listed above can be obtained from the factory.

## H-LAB TECH LETTERS

The following publications contain more detailed information on selected power supply topics.

- Tech. Letter No. 1. Remote Programming
- Tech. Letter No. 2. Constant Voltage/Constant Current Regulated Power Supplies
- Tech. Letter No. 3. Measurement of Line and Load Regulation of DC Power Supplies
- Tech. Letter No. 4. Measurement of Output Impedance of a Constant Voltage Power Supply
- Tech. Letter No. 5. Method of Achieving Constant Current Operation Utilizing a Constant Voltage Power Supply
- Tech. Letter No. 6. Measurement of Transient Recovery Time of Constant Voltage Regulated DC Power Supplies

Copies of any of the above Tech Letters are available at no charge either from your local H-Lab/HP sales office\* or by writing directly to the factory. Feel free to contact either the factory or your nearest sales office with regard to any power supply questions.

\*See page 54.

## POWER SUPPLY LISTING

OUTPUT VOLTS	OUTPUT AMPS	MODEL	LOAD REGULATION (MV)	LINE REGULATION (MV)	RMS RIPPLE & NOISE (MV)	MAX. OPERATING AMBIENT	RECOVERY TIME* (μ-SEC)	INPUT LINE VOLTAGE	INPUT LINE FREQUENCY	METER(S) PROVIDED	REMOTE PROGRAMMING	REMOTE SENSING	BENCH MODEL	RACK MODEL**	NET WEIGHT (kg)	SIZE (mm)	Constant Voltage/Constant Current Operation** Auto-Series/Auto-Parallel Auto-Trailing	SPECIAL FEATURES	PRICE
0-7.5	0-3	6283A	5 mv	3 mv	0.2	50° C	50	105-125 or 210-250	48-440	V/A	✓	✓	✓	R	8,1	89 H x 330 D x 210 W	✓	Front and rear output terminals, half rack width package. Variable voltage and current limit.	\$ 189.00
0-18	0-0.3	6343A	3 mv or 0.03 %	3 mv or 0.03 %	1.0	50° C	50	105-125 or 210-250	48-440	NO	✓	✓		R	1,4	63 H x 203 D x 76 W	✓	Plug-in module — all input, output, and control connections via 11-pin plug. Variable current limit.	130.00
0-18	0-0.6	6968A	10 mv	10 mv	0.1	55° C	50	110/115/ 220/230 ± 10 %	50	V&A	✓	✓	✓	R	4,5	155 H x 278 D x 130 W	✓	Dual range output selected by front panel push buttons. Variable current limit. Third modular cabinet. Other range—0—36 V, 0—3.3 A.	145.00
0-18	0-0.6	6294A 6294AM	4 mv plus 0.01 %	4 mv plus 0.01 %	0.2	50° C	50	105-125 or 210-250	48-440	NO V&A	✓	✓	✓	R	5,4	89 H x 254 D x 210 W	✓	Front and rear output terminals, half rack width package, dual range output selected by front panel push buttons. Other range—0—36 V, 0-0.3 A. Variable current limit.	134.00 154.00
0-18	0-1	6344A	3 mv or 0.03 %	3 mv or 0.03 %	1.0	50° C	50	105-125 or 210-250	48-63	NO	✓	✓		R	3,2	76 H x 228 D x 127 W	✓	Plug-in module — all input, output, and control connections via 11-pin plug. Variable current limit.	175.00
0-18	0-2.5	6345A	3 mv or 0.03 %	3 mv or 0.03 %	1.0	50° C	50	105-125 or 210-250	48-63	NO	✓	✓		R	5,9	127 H x 228 D x 159 W	✓	Plug-in module — all input, output, and control connections via 11-pin plug. Variable current limit.	235.00
0-18	0-3	6224A	2 mv or 0.03 %	2 mv or 0.02 %	0.5	50° C	50	105-125 or 210-250	50-70	V/A	✓	✓	✓	R	6,8	171 H x 279 D x 130 W	✓	Front and rear output terminals, one-third rack width package. Variable voltage and current limit.	340.00
0-18	0-10	6964A	0.01 % or 1 mv	0.01 % or 1 mv	0.5	50° C	50 Δ 5 A	110/115/ 220/230 ± 10 %	50	V&A	✓	✓	✓	✓	14	89 H x 476 D x 483 W	✓	Variable voltage and current limit.	445.00
0-18	0-10	6363A	1 mv or 0.01 %	1 mv or 0.01 %	0.5	50° C	50	105-125 or 210-250	50-60	NO	✓	✓		✓	15,3	89 H x 476 D x 483 W	✓	Well-regulated "stripped-down" version of Model 6964A.	369.00
0-18	0-20	6264A†	1 mv or 0.01 %	1 mv or 0.01 %	1.0	50° C	50	105-125 or 210-250	50-60	V&A	✓	✓		✓	24,3	133 H x 476 D x 483 W	✓	Variable voltage and current limit.	535.00
0-18	0-20	6364A	1 mv or 0.01 %	1 mv or 0.01 %	1.0	50° C	50	105-125 or 210-250	50-60	NO	✓	✓		✓	23,4	133 H x 476 D x 483 W	✓	Well-regulated, "stripped-down" version of Model 6264A.	460.00
0-20	0-1.5	6961A	0.015 % ± 2.5 mv	0.025 % ± 250 μV	0.2	50° C	50	110/115/ 220/230 ± 10 %	50	V&A	✓	✓	✓	R	8	89 H x 350 D x 210 W	✓	Dual range output selected by front panel push buttons. Variable voltage and current limit.	199.00
0-20	0-1.5	6962A	0.015 % ± 2.5 mv	0.025 % ± 250 μV	0.2	50° C	50	110/115/ 220/230 ± 10 %	50	V/A	✓	✓	✓	R	8	89 H x 350 D x 210 W	✓	Front and rear output terminals, half rack width package. Variable voltage and current limit.	169.00
0-30	0-0.15	721A	30 mv or 0.3 %	± 15 mv or 0.3 %	0.15	50° C	—	115/230 ± 10 %	50-60	V/A				✓	1,8	172 H x 133 D x 178 W		4-position current limit switch.	145.00

# POWER SUPPLY LISTING

OUTPUT VOLTS	OUTPUT AMPS	MODEL	LOAD REGULATION (MV)	LINE REGULATION (MV)	RMS RIPPLE & NOISE (MV)	MAX. OPERATING AMBIENT	RECOVERY TIME* (1/2-SEC)	INPUT LINE VOLTAGE	INPUT LINE FREQUENCY	METER(S) PROVIDED	REMOTE PROGRAMMING	REMOTE SENSING	RACK MODEL	NET WEIGHT (kg)	SIZE (mm)	Constant Voltage/Constant Current Operation** Auto-Series/Auto-Parallel Auto-Tracking	SPECIAL FEATURES	PRICE
0-32	0-1	6206A	4 mv plus 0.01 %	4 mv plus 0.01 %	0.2	50° C	50	105-125 or 210-250	48-440	NO V&A	V	V	R	8,1	89 H x 330 D x 463 W	V	Front and rear output terminals, half rack width package, dual range output selected by front panel push buttons. Other range — 0-64 V, 0-0.5 A. Variable current limit.	174.00
		6206AM																194.00
0-32	0-2	6242A†	3 mv or 0.02 %	5 mv or 0.03 %	0.2	50° C	50	105-125 or 210-250	50-400	V&A	V	V	V	11,3	89 H x 476 D x 483 W	V	Plug-in printed circuit selects dual output range, other range — 0-64 V, 0-1A. Variable voltage and current limit.	435.00
0-36	0-0.15	6346A	3 mv or 0.02 %	3 mv or 0.02 %	1.0	50° C	50	105-125 or 210-250	48-440	NO	V	V	R	1,4	63 H x 203 D x 76 W	V	Plug-in module — all input, output, and control connections via 11-pin plug. Variable current limit.	130.00
0-36	0-0.3	6960A	10 mv	10 mv	0.1	55° C	50	110/115/ 220/230 ± 10 %	50	V&A	V	V	R	4,5	155 H x 278 D x 130 W	V	Dual range output selected by front panel push buttons. Variable current limit. Third module cabinet.	145.00
0-36	0-0.3	6204A	4 mv plus 0.01 %	4 mv plus 0.01 %	0.2	50° C	50	105-125 or 210-250	48-440	NO V&A	V	V	R	5,4	89 H x 254 D x 210 W	V	Front and rear output terminals, half rack width package, dual range output selected by front panel push buttons. Other range — 0-18 V, 0-0.6 A. Variable current limit.	134.00
		6204AM																154.00
0-36	0-0.5	6347A	3 mv or 0.02 %	3 mv or 0.02 %	1.0	50° C	50	105-125 or 210-250	48-63	NO	V	V	R	3,2	76 H x 228 D x 127 W	V	Plug-in module — all input, output, and control connections via 11-pin plug. Variable current limit.	175.00
DUAL 0-36	0-1.5	802B	3.6 mv or 0.01 %	3.6 mv or 0.01 %	0.2	50° C	100	105-125	50-400	V&A	V	V		12,6	89 H x 381 D x 483 W		Two sides can be seriesed for 0-72 V at 0-1.5 A. Fixed current limit.	580.00
0-36	0-1.5	6226A	2 mv or 0.02 %	2 mv or 0.02 %	0.5	50° C	50	105-125 or 210-250	50-70	V/A	V	V	R	6,8	172 H x 280 D x 130 W	V	Front and rear output terminals, one-third rack width package. Variable voltage and current limit.	325.00
0-36	0-1.5	6348A	3 mv or 0.02 %	3 mv or 0.02 %	1.0	50° C	50	105-125 or 210-250	48-63	NO	V	V	R	5,9	127 H x 229 D x 159 W	V	Plug-in module — all input, output, and control connections via 11-pin plug. Variable current limit.	235.00
0-36	0-3	6244A†	5 mv or 0.02 %	2 mv or 0.01 %	0.5	50° C	50	105-125 or 210-250	50-70	V&A	V	V	V	11,3	89 H x 476 D x 483 W	V	Variable voltage and current limit.	460.00
0-36	0-3	6265A†	1 mv or 0.01 %	1 mv or 0.01 %	0.5	50° C	50	105-125 or 210-250	50-60	V&A	V	V	V	16,2	89 H x 476 D x 483 W	V	Variable voltage and current limit.	360.00
0-36	0-3	6365A	1 mv or 0.01 %	1 mv or 0.01 %	0.5	50° C	50	105-125 or 210-250	50-60	NO	V	V	V	15,3	89 H x 476 D x 483 W	V	Well-regulated, "stripped-down" version of Model 6265A.	289.00
0-36	0-5	6965A	0.01 % or 1 mv	0.01 % or 1 mv	0.5	50° C	50	110/115/ 220/230 ± 10 %	50	V&A	V	V	V	13,5	89 H x 476 D x 483 W	V	Variable voltage and current limit.	445.00
0-36	0-5	6366A	1 mv or 0.01 %	1 mv or 0.01 %	0.5	50° C	50	105-125 or 210-250	50-60	NO	V	V	V	15,3	89 H x 476 D x 483 W	V	Well-regulated, "stripped-down" version of Model 6965A.	369.00

## POWER SUPPLY LISTING

OUTPUT VOLTS	OUTPUT AMPS	MODEL	LOAD REGULATION (MV)	LINE REGULATION (MV)	RMS RIPPLE (MV)	MAX. OPERATING NOISE (MV)	RECOVERY TIME* (μSEC)	INPUT LINE VOLTAGE	INPUT LINE FREQUENCY	METER(S) PROVIDED	REMOTE PROGRAMMING	BENCH SENSING	RACK MODEL	NET WEIGHT (kg)	SIZE (mm)	Constant Voltage/Constant Current Operation** Auto-Series/Auto-Parallel Auto-Tracking	SPECIAL FEATURES	PRICE
0-36	0-10	6966A	0.01 % or 1 mv	0.01 % or 1 mv	0.5	50°C	50 Δ 5A	110/115/ 220/230 ± 10 %	50	V & A	✓	✓	✓	20	133 H x 476 D x 483 W	✓	Variable voltage and current limit.	535.00
0-36	0-10	6367A	1 mv or 0.01 %	1 mv or 0.01 %	0.5	50°C	50	105-125 or 210-250	50-60	NO	✓	✓	✓	23,4	133 H x 427 D x 483 W	✓	Well-regulated, "stripped-down" version of Model 6966A.	460.00
0-40	0-0.5	723A	20	10	0.15	55°C	—	115/230 ± 10 %	50-1000	V/A	✓	✓	R	5,4	172 H x 305 D x 130 W	✓	Variable current limit.	240.00
0-40	0-0.75	6961A	0.015 % ± 2.5mv	0.025 % ± 250 μV	0.2	50°C	50	110/115/ 220/230 ± 10 %	50	V & A	✓	✓	R	8	89 H x 350 D x 210 W	✓	Dual range output selected by front panel push buttons. Variable voltage and current limit.	199.00
0-40	0-0.75	6963A	0.015 % ± 2.5mv	0.025 % ± 250 μV	0.2	50°C	50	110/115/ 220/230 ± 10 %	50	V/A	✓	✓	R	8	89 H x 350 D x 210 W	✓	Front and rear output terminals, half rack width package. Variable voltage and current limit.	169.00
0-60	0-2	726AR	5	2.5	0.25	55°C	200	115/230 ± 10 %	50-60	V & A	✓	✓	✓	11,3	133 H x 305 D x 483 W	✓	Front and rear output terminals. Variable current limit.	595.00
0-60	0-3	6271A†	3 mv or 0.01 %	3 mv or 0.01 %	0.5	50°C	50	105-125 or 210-250	50-60	V & A	✓	✓	✓	16,2	89 H x 476 D x 483 W	✓	Variable voltage and current limit.	445.00
0-60	0-3	6371A	3 mv or 0.01 %	3 mv or 0.01 %	0.5	50°C	50	105-125 or 210-250	50-60	NO	✓	✓	✓	15,3	89 H x 476 D x 483 W	✓	Well-regulated, "stripped-down" version of Model 6271A.	369.00
0-64	0-0.5	6206A 6206AM	4 mv plus 0.01 %	4 mv plus 0.01 %	0.2	50°C	50	105-125 or 210-250	48-440	NO V & A	✓	✓	R	8,1	89 H x 330 D x 210 W	✓	Front and rear output terminals, half rack width package, dual range output selected by front panel push buttons. Other range — 0-32 V, 0-1 A. Variable current limit.	174.00 194.00
0-64	0-1	6242A†	3 mv or 0.02 %	5 mv or 0.03 %	0.2	50°C	50	105-125 or 210-250	50-400	V & A	✓	✓	✓	11,3	89 H x 476 D x 483 W	✓	Plug-in printed circuit card selects dual output range, other range — 0-32 V, 0-2 A. Variable voltage and current limit.	435.00
0-160	0-0.2	6207A	2 mv plus 0.02 %	2 mv plus 0.02 %	0.5	50°C	50	105-125 or 210-250	50-63	V/A	✓	✓	R	6,1	89 H x 330 D x 210 W	✓	Front and rear output terminals, half rack width package. Variable voltage and current limit.	204.00
0-500	0-0.1	711A+ 711AR+	1000 or 0.5 %	1000 or 0.5 %	1	50°C	—	115-230 ± 10 %	50-1000	V & A	✓	✓	✓	9 10,8	292 H x 368 D x 187 W 178 H x 324 D x 483 W	✓	Two ranges on voltmeter and ammeter — 12.6 VAC CT auxiliary 3A output. Overload protection includes AC line fuse and DC protection relay.	275.00 280.00
-250 to -800 0 to -800 6.3V (ADJ)	0-0.1 0-2.0	716B+	0.05 % — —	0.05 % 0.05 % 1 %	1 0.5 2	50°C	—	115/230 ± 10 %	50-60	A	✓	✓	✓	20,3	191 H x 477 D x 426 W	✓	Klystron supply. Direct reading calibrated voltage controls. Choice of internal and external modulation. Sync output for scope. Diode protection circuit.	875.00

**All Supplies:** Floating output (ground either side), continuously variable output, low output impedance at all frequencies, 3-wire input, computer-quality electrolytics, 1 year warranty. No turn-on, turn-off overshoot; short circuit proof, all semi-conductor except as noted by +

**Transistor Supplies:** Glass-epoxy printed circuit board construction, fully automatic overload protection — short circuit proof.

\* Time required for output voltage recovery to within "Y" millivolts of the nominal output voltage, where "Y" is the load regulation and the nominal output voltage is defined as the mean between the no load and full load voltages.

† Cheaper Stabilized Units also available at \$ 125.00 extra.

\*\* Units with "V" in this column feature automatic crossover between constant voltage and constant current operation; whereas units with "X" are converted from constant voltage to constant current or from constant current to constant voltage operation by means of substituting plug-in printed wiring card and rearranging straps on rear barrier strip.

\*\*\* Units with "R" in Rack Model Column can be rack mounted utilizing optional panels.