

My experience with the ANC-4 on 50 MHz – Rev. 1

by Antonio Vernucci, IOJX

1. General

The ANC-4 (Antenna Noise Canceller - 4) is intended to reduce the impairment of weak DX signals reception caused by local interference sources. It was originally marketed by JPS Communications; now I see it advertised by Timewave (www.timewave.com).

The ANC-4, which operates in conjunction with any receiver up to about 80 MHz, works very well on 6-meter, a band which is often plagued by nearby man-made interference (lamps, leaky power-line insulators, sparking devices, computers, TV sets, etc.).

2. Principle of Operation

The ANC-4 design aims to reduce interference caused by a single source, obviously not by "white" background noise. Therefore "interference canceller" would have been a more appropriate name than "noise canceller". The ANC-4 operates on the well-known technique to suppress interference by adding to it an identical waveform (the "cancellation waveform"), with same amplitude but 180 degrees out of phase.

To achieve this, the ANC-4 has provisions for:

- producing the cancellation waveform with a sufficient amplitude (as explained later);
- (manually) adjusting the amplitude and phase of said waveform;
- adding the so-adjusted cancellation waveform to the DX signal coming from the "main antenna", and feeding the composite signal to the receiver.

The simplest approach to produce the cancellation waveform is to amplify the signal coming from another antenna (called the "noise antenna") which should (ideally) only pick up the interfering signal and not the DX signal. For this purpose, the ANC-4 has a coaxial socket to which the noise antenna can be connected, as shown below. Picture also shows that the ANC-4 has circuitries (gain-control, phase-control and signals adder) for adjusting the cancellation waveform amplitude and phase, and for summing it to the signal coming from the main antenna, before delivery to the transceiver (or receiver).

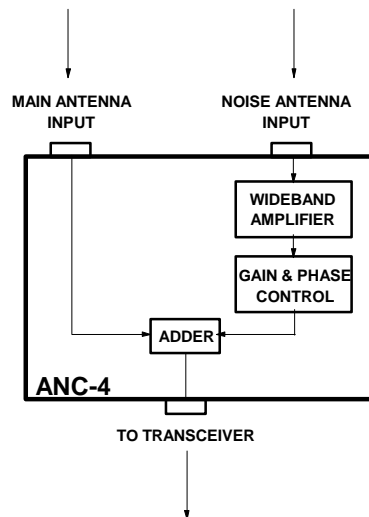

3. What is a local Interference?

Trying to use the ANC-4 to mitigate interference coming over a ionospheric propagation path (as occurring in the HF bands) would not work, because it is not practically possible to maintain a fixed phase- and amplitude-relationship between the interference signals as appearing at the main and the noise antenna. On the contrary, local interference coming over a direct propagation path can instead well be cured.

In practice, the ANC-4 can be helpful for two categories of interference, i.e.,:

- what I call the *very*-local interference, i.e. that coming from around the operator position, or from his very house (TV sets, computer, lamps);
- what I call the *fairly*-local interference, i.e. that coming from nearby places, say up to 2 Km away or so.

To my opinion, the *very*-local interference case is of little interest as, when the interference source is so close, it is usually fairly easy to locate it. Once you have isolated it, it would more sensible to eliminate it rather than using the ANC-4 (though I well know that computer-generated interference is sometimes hard to kill). Nevertheless the ANC-4 was conceived to also tackle the *very*-local interference case; as a matter of fact it comes with a short whip, acting as a noise antenna, which can be directly screwed into a hole of the ANC-4 cabinet. The whip antenna is quite an ideal antenna for cancellation purposes, in that it will (nearly) only receive the interfering signal; nevertheless it can only pick up a sufficient interference level from very close sources and is therefore only good in such condition. I never had occasion to test the ANC-4 using its whip antenna, as I never got a *very*-local interference sufficiently strong to reliably evaluate the ANC-4 performance.

The *fairly*-local interfering source case is the one of real interest. As a matter of fact it is quite common getting interfered by leaky powerlines insulators, or faulty neon lamps, and it is not always easy to locate the interference source. Once you have found it, it may not always be easy to eliminate it. In conclusion the ANC-4 can be very useful for this case.

To pick-up up a far-generated interference you will have to use an outdoor noise antenna. They recommend to use a short dipole, but my experience has shown that using a low-gain antenna (dipole, vertical, etc.) would not be adequate for the 6-meter case.

As a matter of fact, to achieve interference cancellation, the two interference signal replicas (i.e. that coming from the main antenna and that from the noise antenna) must have identical amplitudes at the addition point within the ANC-4, this meaning that the interference level coming from the noise antenna should be high enough to permit adjusting it, within the ANC-4 gain-control range, to the same level of that coming via the main antenna.

Unfortunately the internal ANC-4 wideband amplifier gain is generally insufficient and, with a low-gain noise antenna, one does not normally succeed to achieve interference cancellation, even with the gain-control being set to maximum.

4. A Solution

Initially, I have just added an external pre-amplifier in the noise-antenna path, as shown in the figure below, which significantly increases the interference level coming from the noise antenna (by the way, the preamplifier also serves to reduce the bandwidth of the noise-antenna path, as that path would otherwise be fully wideband; anyway, in my case, I never experienced problems in this respect).

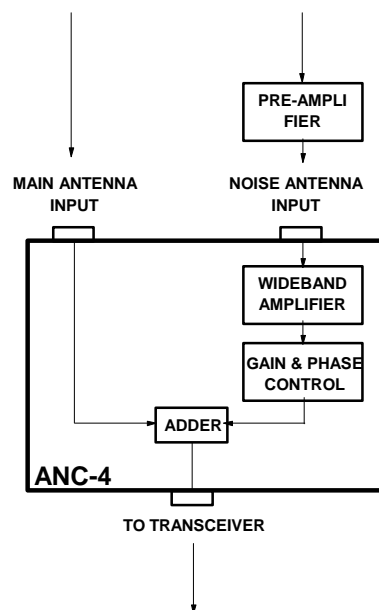

However, this solution does not help much if used in conjunction with a low-gain noise antenna. You would easily realize that, increasing the pre-amplifier gain up to when the interference level has got high enough for cancellation purposes, also the noise floor has grown up to an intolerable extent. In conclusion, the preamplifier helps, but unfortunately you must also have a "good" noise antenna.

Me having two identical 5-element Yagis, on separate towers, I then tried to use one Yagi as the main antenna and the other Yagi as the noise antenna, the latter being obviously kept steadily and pointed to the interference source. This set-up works very

fine, though in some cases I realized that the preamplifier on the noise-antenna path was still needed.

5. How Effective is Noise Cancellation?

Finding the setting at which maximum cancellation occurs, by adjusting the noise-phase and noise-gain front-panel controls, is sometimes critical, but interference attenuation will then be very high (I got 40 dB or more).

The amount of interference suppression will also depend on how different the DX station heading is from that of the interference source.

Suppose that the DX station comes from 100 degrees and interference from 50 degrees. You will then point the main antenna to 100 degrees (from where it will receive a good signal from the DX station and some interference), and the noise antenna to 50 degrees (from where it will pick-up a strong interference signal and only a weak signal from the DX). In this case the ANC-4 can be very effective: as a matter of fact, once the ANC-4 phase- and gain-controls have been adjusted for maximum interference cancellation, the two replicas of the DX signals (i.e. those captured by the main and by the noise antenna) will not cancel themselves out, in virtue of their great amplitude imbalance and random mutual phase at the addition point.

Conversely, should the DX station and interference both come from exactly the same heading, once you have adjusted the ANC-4 controls for maximum interference suppression, you will sadly realize that also the DX signal interference has been nulled out. No big deal!

In conclusion, the higher the heading difference is, the greater interference cancellation will generally turn out to be. I have experienced that a 35-degree shift is high enough to achieve good interference cancellation.

A nuisance is the fact that, every time you turn the main antenna to a different heading, you will have to re-null interference, due to the change of the amplitude and phase relationships.

Another inconvenience is that the noise antenna may also receive other DX signals which the main antenna does not. Such signals may interfere the DX signal you are receiving via the main antenna, so you may have to compromise.

6. An Even Better Arrangement

The ANC-4 built-in signal adder involves, by nature, a 3-dB loss in the DX signal path, this fact causing an impairment of the receive system noise figure. This may not be a terrible problem for hams living in populated areas, where the man-made noise level may largely exceed that of the receiver thermal noise. Others may not want to tolerate such a loss; for them I suggest the approach shown below.

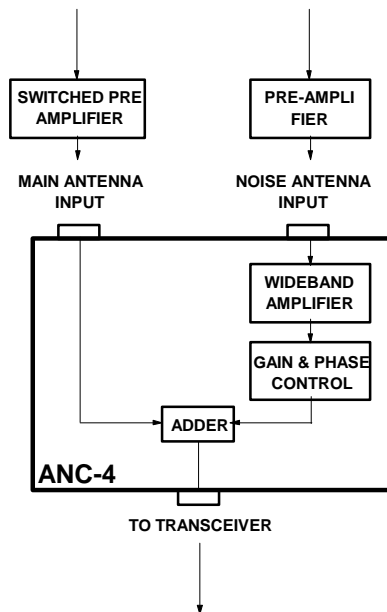

Another pre-amplifier has been inserted in the main-antenna path; this must be a RF-switched preamplifier (bypassed on transmit). In this way, signals addition occurs after pre-amplification, and the noise figure degradation can so be kept negligible. With a pre-amplifier on the main antenna path, a pre-amplifier on the noise antenna path becomes a real must to achieve equal interference levels at the addition point.

7. The Most Convenient Arrangement

The ANC-4, as it is, does not offer enough operational flexibility to satisfy my taste. Firstly, it lacks the pre-amplifiers; secondly, I would like to be able separately hearing signals coming from the main-antenna and the noise-antenna signals before trying interference cancellation. So I decided to built a more elaborated circuitry around the ANC-4. The needed extra items are:

- two plain 50-MHz pre-amplifiers, with no switching relays. I actually bought two cheap 27-MHz pre-amplifier kits at low price, and re-tuned them to 50 MHz;
- three small coaxial relays handling 100W RF. Mine, built by Magnecraft, have no connectors (just coaxial wires);
- one SP3T switch;
- a few transistors, diodes, resistors, etc.

The schematic diagram of my arrangement is shown below.

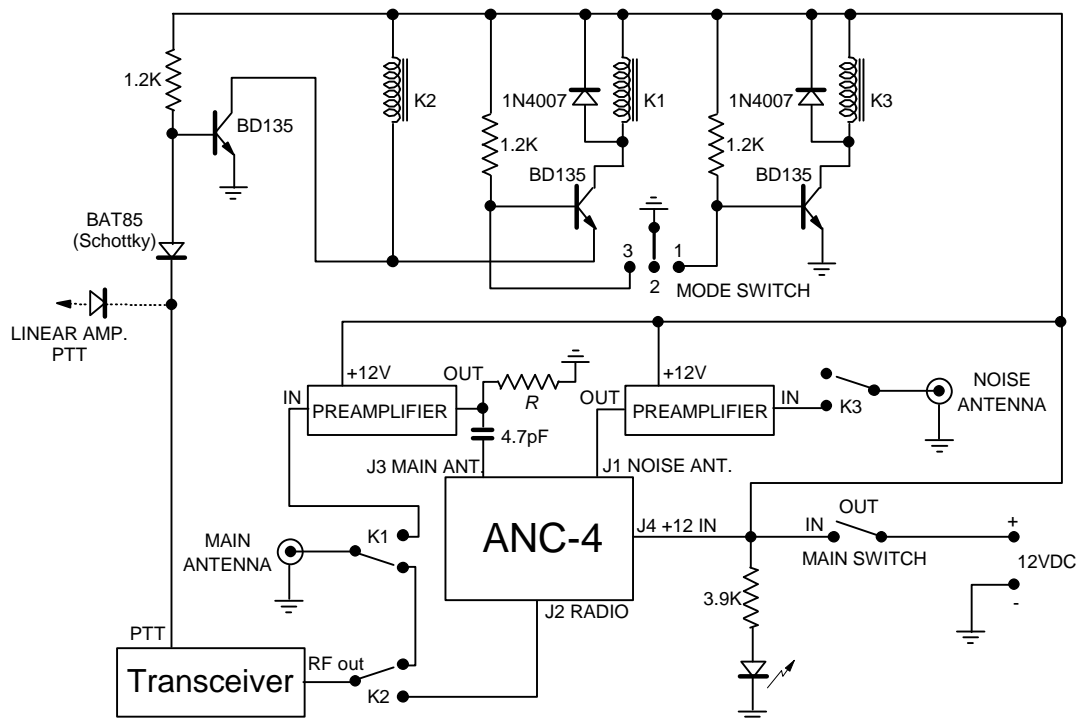

Operation is very simple:

- Main Switch at OUT: everything is by-passed and the main antenna is directly connected to the transceiver.
- Main Switch at IN:
 - * Mode Switch at 1: you only hear the signal coming from the main antenna, the level of which is independent of the ANC-4 settings;
 - * Mode Switch at 2: you hear the sum of the signals coming from the two antennas, and you can then adjust the ANC-4 noise phase and gain controls for maximum interference cancellation;
 - * Mode Switch at 3: you only hear the signal coming from the noise antenna, the level of which depends on the ANC-4 noise gain setting;

The pre-amplifier on the main antenna path needs to have a gain of a few dBs, just to recover the internal ANC-4 loss; at the same time the it must withstand the presence of some RF power at its output, because, when switching on transmit, there could be a short period in which RF power appears at its output. A simple solution is to use a normal-gain pre-amplifier (say 15 to 20 dB) and couple it very loosely (via a 4.7 pF capacitor) to the transceiver. Further help in this respect is provided by resistor *R*, which is to be adjusted so that the main-antenna pre-amplifier gain just compensates for the ANC-4 internal loss. To adjust *R*, tune the receiver on a steady carrier; the value of *R* will be correct when you obtain the same S-meter reading for:

- Main Switch at OUT;
- Main Switch at IN and Mode Switch at 1.

In my, case the appropriate value for *R* was 120 ohm.

Last remark: the proposed circuit needs a command from the transceiver PTT. If you use a linear amplifier, do not forget to insert a series-diode on the linear PTT line, as shown in the diagram.

The following picture shows the set-up during the testing phase (you can clearly see the three coaxial relays, the ANC-4 hidden by them and the wattmeter on top of it, and the two small pre-amplifier printed circuits). All that stuff will eventually be housed in a box.

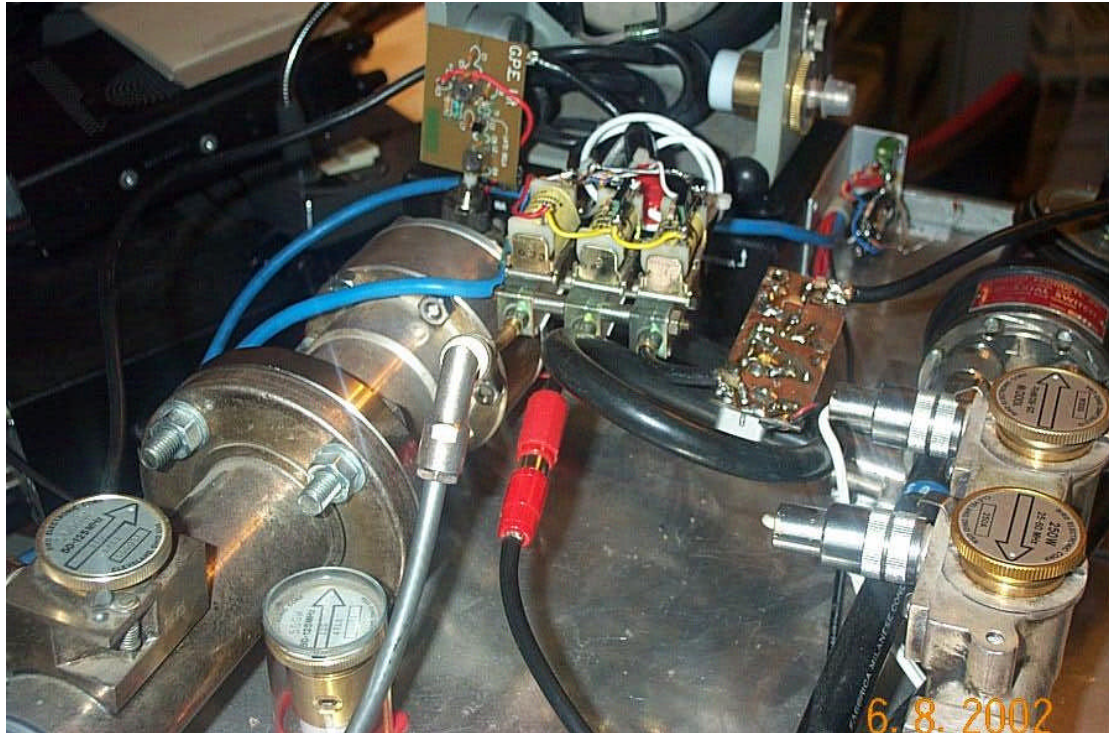

8. Conclusions

I have recently tested the arrangement described in Sect. 7 over an S-9 interference (sounding like a buzzing 50-Hz signal) which has suddenly start to appear a few hours a day. I have found the area where it comes from (about 1.5 km from my shack), but I have not yet been able to precisely spot it.

The amount of cancellation I can get is AMAZING: once knobs are properly adjusted, the interference FULLY disappears, while the DX signal remains unaffected. Just two remarks:

- knob adjustment IS critical;
- if there is strong wind, the antennas pointing varies a bit in random manner, and this is sufficient to hear interference going up and down somewhat.

From other tests I did some time ago, it is confirmed that:

- up to a 35-degree shift between the DX heading and that of the interference source, a remarkable improvement can be obtained:

- no improvement at all instead occurs when both signals come from the same heading.

Even if you have no local interference problems, you may still find it convenient to utilize an ANC-4, provided that you have two independent but (approximately) equal-gain antennas connected to the ANC-4 main-antenna and noise-antenna sockets. You can then improve DX signal reception by having both antennas pointed to the DX station, and adjusting the ANC-4 controls such that the two signals add up to each other, within the ANC-4, with same phase and equal amplitude. In a way, you can visualize the situation as if you would have stacked the two antennas on the same tower and properly coupled them.

Also in this case the position of the ANC-4 phase- and gain-control will have to be varied every time the antennas heading is changed; nevertheless knobs adjustment is by far less critical than when using the ANC-4 for interference cancellation.

In conclusion, the ANC-4 works very fine on 50 MHz and can then be useful for 6-meter operators. I would be nice if the manufacturer would decide to also sell an enhanced version of the ANC-4 integrating the two pre-amplifiers as well as a switching circuitry, in a manner equivalent that described in Sect. 7.