

K2 DIGITAL INTERFACE

v.II.2

**Mike Configuration Header Extender
and
Rear Panel Data Connector for the K2**

(Plus other useful features)

By Paulí Núñez, EA3BLQ

© August 2002

K2 DIGITAL INTERFACE v.II.2

Featuring a Mike Configuration Header Extender and Rear Panel Data Connector

(It includes a buffered, fixed audio output and the cutting of Front Panel mike connector's AF and PTT lines, when transmitting data).

By Paulí Núñez, EA3BLQ © January 2002

Revised on August 2002

Overview

The story begins when on February 2001 *Elecraft* awarded me the honour of publishing my first article on how to modify the K2 to bring out signals for digital modes, with the title "K2's Mic Configuration Header Extender and Rear Panel DATA Connector", as the Elecraft's February 2001 Featured Article. Thanks Elecraft. *(For those of you that may be interested, this article is currently available at my site (www.qsl.net/ea3blq/digital_int_v1.pdf)).*

The need of a way to modify the K2 to bring out signals for digital modes with a fixed and independent audio level was the leitmotif of that article and it is my believe that that need is still quite alive but now I am becoming aware that perhaps I have not yet found a satisfactory solution for the how. I might add that I consider my first approach at the design of a circuit to develop the project quite a success, as my small stock of prototype PCB's (15 units) was allotted in a blink but it soon became stale dated. ;-(

All was ok (or so I thought) until I received some feedback asking me if I could consider the possibility of modifying my circuit in such a way that the front panel mike's AF and PTT lines be cut when transmitting digital data through the rear connector, so as to avoid any chance of a live mike transmitting unwanted sound (shack's noise) along with the digital signal.

I gave a thought to those suggestions and came to the conclusion that, so long as I had extended the K2 mike's configuration header from the Front Panel board to my K2 Digital Interface, for an easy access when needed, the suggested mod was easy to make and at the same time I could improve the circuit that amplifies the received audio coming from J5 at the K2 RF Board.

K2 Digital Interface II.2

The following text and pictures are the result of my efforts to reach that goal: *The K2 Digital Interface II.2* that features a Mike Configuration Header Extender and Rear Panel Data Connector, as well as a buffered, fixed audio output and the cutting of Front Panel mike connector's AF and PTT lines, when transmitting data.

Buffered, fixed audio output:

In this version of my PCB and for consistency sake, I decided to copy the Elecraft's original K2 Audio Amplifier circuit to feed U2, the AF amplifier (LM386N) and to control its audio level. The use of a couple of J310 FET (Q1 and Q2), biased through a 3.3 MOhm resistor, as in the K2, is very useful as it allows the disconnection of the AF amplifier from the product detector on data transmission, thus getting the K2's featured clean QSK.

Cutting the Front Panel mike connector's AF and PTT lines and muting the AF amplifier, when transmitting data:

Due to its low current drain and its switching features, I've chosen the use of a CD4053BE CMOS Analog Multiplexer to cut and commute the AF and PTT lines from the Front Panel Mic Connector to the Rear Digital Connector, when transmitting data, and to disconnect U2, the audio amplifier LM386, from the product detector by grounding the gates of Q1 and Q2, following Elecraft's design.

In the circuit schematic shown on next page, by default, the multiplexer mosfets are biased high due to pins 9, 10 and 11 of U1, CD4053BE CMOS, being fed with 5V DC through R3 (a 10K resistor). In this way we have:

- a) The ground connected at pin 14 of U1 (a) goes nowhere as pin 13 has no connection.
- b) The signal from the AF pin at J1 goes to the AF pin in J2 through pins 15 and 1 of U1 (b) and
- c) The signal from the PTT pin at J1 goes to the PTT pin at J2 through pins 4 and 3 of U1 (c), thus the Front Panel AF and PTT lines are enabled.

Because of the DC component (2.5 V fed through R1 and R2) present in the U1 (b), three 10 µF electrolytic capacitors (one inlet and two outlets of U1) are needed to decouple the DC from the signal.

When the PTT is keyed through the Rear Data Connector, because of data transmission, pins 9, 10 and 11 of U1, CD4053BE, are grounded through pin 3 at J3. Then the voltage at those pins drops to 0 V., setting the multiplexer mosfets low and thus three switching operations are activated:

- 1) U1 (a) - Switches pin 14 from pin 13 to pin 12 and grounds the gates of Q1 and Q2, setting them low and thus disconnecting the AF amplifier.
- 2) U1 (b) - Switches pin 15 from pin 1 to pin 2, connecting the outgoing AF signal from J1 to pin1 of the MiniDIN connector, through pin 1 of J3. The unwanted signal coming from the AF pin at J2 (if any) has no way out.
- 3) U1 (c) - Switches pin 4 from pin 3 to pin7 5, keying the rig by grounding the PTT pin at J1 and disconnecting the PTT line at J2

SCHEMATIC

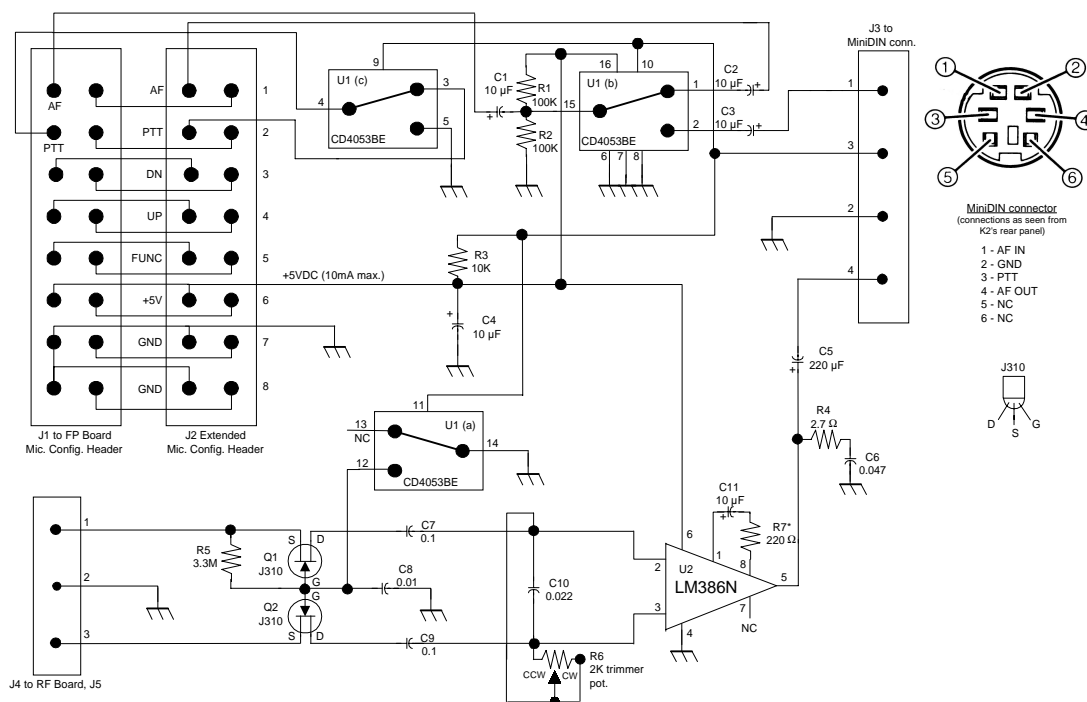

Note: All resistors are 1/4 watt and their value is in ohms; K = 1,000 and M = 1,000,000
 Decimal values of capacitance are in microfarads (µF)
 NC = No connection
 See text for comments on R7*

K2 DIGITAL INTERFACE II.2

Featuring a Mic. Configuration Header Extender and Rear Panel Data Connector

(It Includes a buffered, fixed audio output and the cutting of Front Panel mic. connector's AF and PTT lines, when transmitting data).

© Pauli Núñez, EA3BLQ - July 2001

PRINTED CIRCUIT BOARD

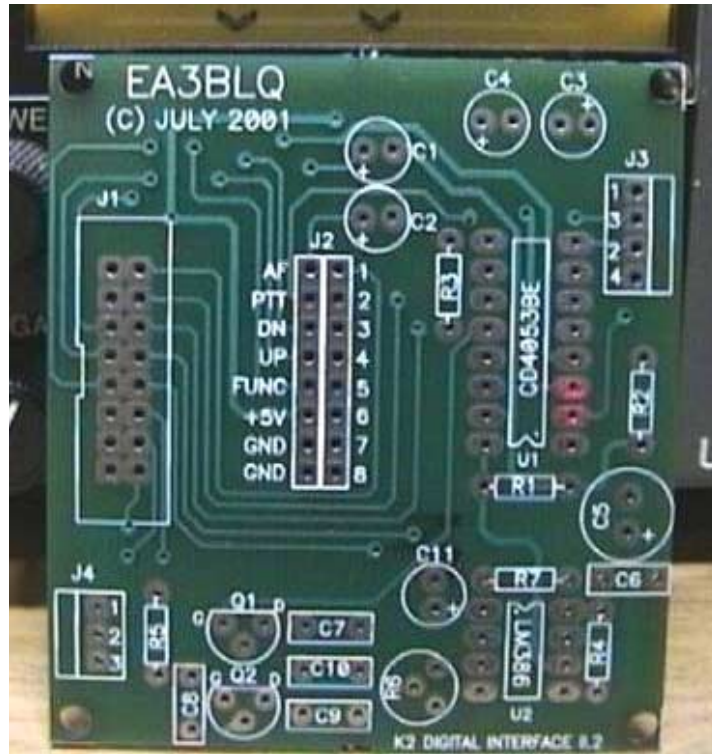

Notice:

This printed circuit board was designed on last July 2001, when I had it installed and working in my K2. At the same time, Jay Rutherford, K1UC, did the field test of the project for me, with good results I might say. Hi Jay, thank you for your invaluable help!

At the time Elecraft had not yet released the KAF2 option and thus there was some room available within the K2 to install the D.I. as I did, but the time came when Elecraft made the KAF2 available and, as I have all the options installed, I ordered it. I constructed the option and I installed it. The KAF2 works fine business but ... Oh dear! ... I had to uninstall my Digital Interface as it collided with the new option. ;-(

My premonitions had come true; the K2 is now so stuffed with all its options and cables that there is little, if any, room left for an alien option or modification.

Well, to cut a long story short, currently my project seems to be valid only for those K2rs that have not installed and do not intend to install the KAF2 option or the internal battery option.

On this account, on the following pages, besides the "Assembly Instructions" and "Parts List", I have included some pictures (the same you may see commented at my web site) showing how I placed and installed the Digital Interface for either option: "No KAF2 Set-up" (Page 7) and "No KBT2 Set-up" (Page 10)

As I have said, the leitmotif is still alive but the how has not been solved yet. Now I am thinking about installing the PCB within an external low profile enclosure, together with a selectable RS232 or VOX PTT control.

BTW, I still have a number of PCBs available, so if you are interested in constructing and installing this project as it is, please contact me at ea3blq@menta.net . Thank you.

Barcelona, Spain, August 2002.

ASSEMBLY INSTRUCTIONS

Please note that all the soldering rules, warnings and tips you have learned and used when assembling your K2, are to be applied in the assembly of this circuit too.

Install and solder components in the following order:

- a) _R1, _R2 100K resistors (brown-black-yellow)
- b) _R3, 10K resistor (brown-black-orange)
- c) _R4, 2.7 Ω resistor (red-violet-gold)
- d) _R5, 3.3Mohm resistor (orange-orange-green)
- e) _R6, 2K trimmer pot (3329H202). By factory default, the trimmer pot is set to its midpoint [\pm 1 Kohm] Once installed, setting R6 clockwise (CW) will increase the resistance and thus the volume level of the signal fed to U2 (LM386 audio amplifier). Obviously, to decrease the volume, R6 is to be set counter-clockwise (CCW).
- f) _R7, 220 Ω resistor (red-red-black) * See text below for notes on this resistor.
- g) _C6, 0.047 μ F (473) capacitor
- h) _C7, _C9, 0.1 μ F (104) capacitors
- i) _C8, 0.01 μ F (103) capacitor
- j) _C10, 0.022 μ F (223) capacitor
- k) _Q1, _Q2, J310 FET
- l) _J1, IDC socket 16 pin male (dual row)
- m) _J2, Dual row connector (16 pin male)
- n) _J3, Connector w/locking tab (4 pin male)
- o) _J4, Connector w/locking tab (3 pin male)
- p) _C1, _C2, _C3, _C4, _C11, 10 μ F 16/25v electrolytic capacitors
- q) _C5, 220 μ F 16/25v electrolytic capacitor
- r) _U1, CD4053BE or HEF4053BP CMOS (16 pins)
- s) _U2, LM386 low voltage audio amplifier (8pins)

(*) NOTES ON THE R7 RESISTOR'S VALUE TO CONTROL LM386's GAIN.

The manufacturer's General Description of the LM386 reads: "...The gain is internally set to 20 to keep external part count low, but the addition of an external resistor and capacitor between pins 1 and 8 will increase the gain to any value up to 200."

The factory default gain of \pm 20, attained through the inner 1.35Kohm resistor allocated between pins 1 and 8 is too low for our needs.

On the other way if we externally bypass that resistor by inserting a 10 μ F electrolytic capacitor between those pins (+ lead to pin 1) the gain is increased to 200. Good enough to drive a 4 Ω speaker but too high for the sound card, as it gets overdriven.

On this account and by inserting one external resistor in parallel with the inner resistor and in series with the electrolytic capacitor, between pin 8 of the IC and the (-) lead of the capacitor, we may set that gain to the level that meets with our needs, within the range of 20-200, .

As a result of some computing, I've got the following options for R7's resistor value:

- 1) One 1.2Kohm resistor (brown-red-red) will render a gain of about 50 (perhaps a bit on the low side)
- 2) One 330 Ω resistor (orange-orange-brown) will render a gain of about 75
- 3) One 220 Ω resistor (red-red-brown) will render a gain of about 90.
- 4) One 180 Ω resistor (brown-gray-brown) will render a gain of about 100 and
- 5) One 100 Ω resistor (brown-black-brown) will render a gain of about 125

I have chosen option #3, but the builder may choose the option he/she thinks most suitable for his/her needs and/or preferences.

EA3BLQ's DIGITAL INTERFACE v.II.2 PARTS LIST

DESIGNATORS	VALUE	DESCRIPTION	QTY
C1, C2, C3, C4, C11	10 μ F 16/25v	Electrolytic capacitor	5
C5	220 μ F 16/25v	Electrolytic capacitor	1
C8	.01	Capacitor "103"	1
C10	.022	Capacitor "223"	1
C6	.047	Capacitor "473"	1
C7, C9	.1	Capacitor "104"	2
J1	IDC Socket	16 pin male (dual-row)	1
J1 and Microphone Configuration Header at FP board	IDC Female connector for ribbon flat cable.	FC-16P (16 pin female dual row)	2
J2	Dual-row connector	16 pin male	1
J3	Connector with locking tab	4 pin male	1
J3	Housing	4 pin female	1
J4	Connector with locking tab	3 pin male	1
J5 at the RF board	Connector	3 pin male	1
J4 & J5 at RF board	Housing	3 pin female	2
J3,J4 and J5 at RF b	Miscellaneous	female crimp pins for the housings	10
Q1, Q2	J310	FET TO-92	2
R4	2.7 Ω	Resistor (red-violet-gold)	1
R3	10K	Resistor (brown-black-orange)	1
R1, R2	100K	Resistor (brown-black-yellow)	2
R5	3.3M	Resistor (orange-orange-green)	1
R6	2K POT 3329H202 or T7YB	Trimmer pot for audio level adjustment	1
R7 (*)	220 Ω	Resistor (red-red-brown) See text for comments on R7 (*)	1
U1	CD4053BE or HEF4053BP	CMOS (16 pins)	1
U2	LM386N	Low Voltage Audio Amplifier (8 pins)	1
Dig. Interface v.II.2	Miscellaneous	Printed Circuit Board	1

Revised on August 8, 2002

No KAF2 Set-up Option Pictures

(Pages 7 to 9)





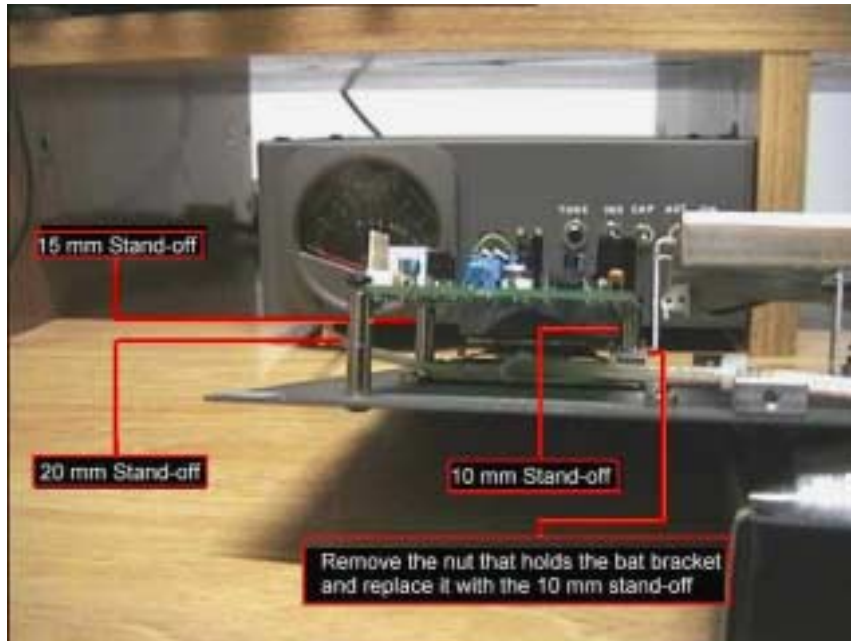

No KBT2 Set-up Option Pictures

(Pages 10 to 13)

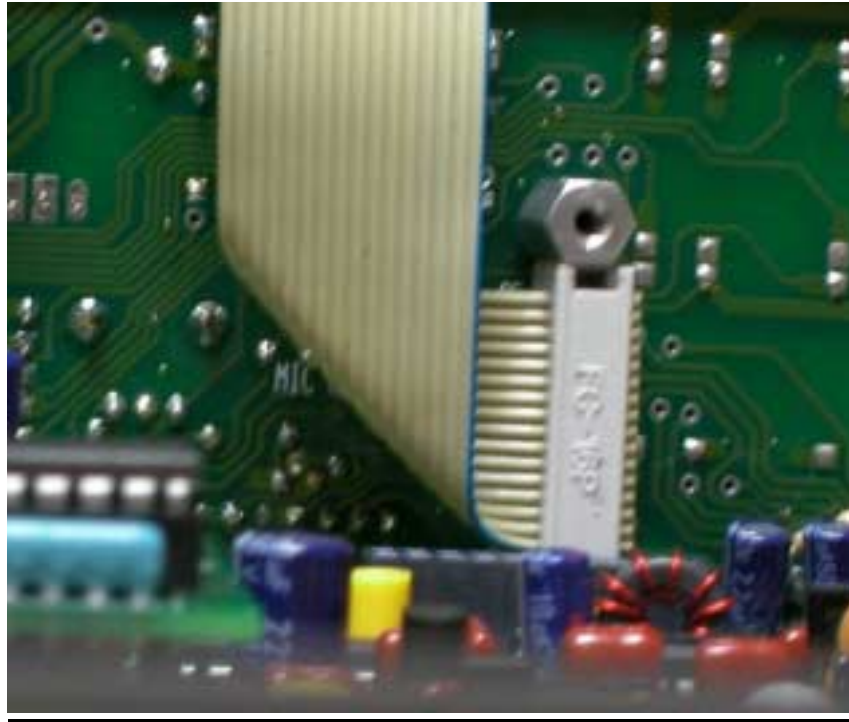

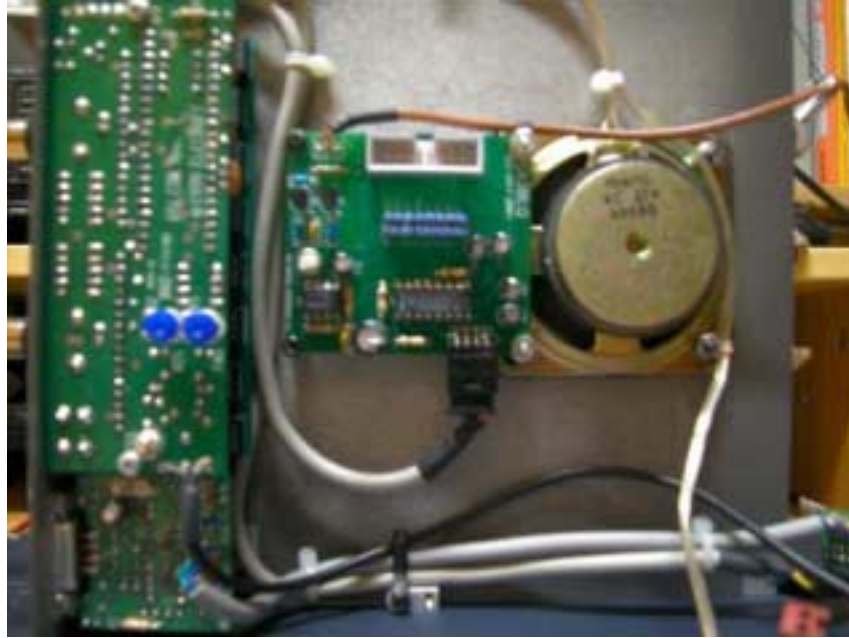





NOTES