

# A New Look at SDR Testing

*(presented at SDR Academy 2016, Friedrichshafen, Germany)*

Adam Farson VA7OJ/AB4OJ

*Copyright © 2016 A. Farson VA7OJ/AB4OJ*

# Performance issues in direct-sampling SDR receivers

- Many of the “standard” tests for legacy receivers are also applicable to direct-sampling SDR’s:
  - MDS (Minimum Discernible Signal)
  - Phase Noise (measured as RMDR, Reciprocal Mixing Dynamic Range)
  - Front-End IMD (2<sup>nd</sup>- and 3<sup>rd</sup>-order)
  - Detection Filter Parameters (BW, shape factor, stopband attenuation)
  - AGC Threshold & S-meter Tracking
  - Notch filter depth
  - NR and NB performance
  - etc.
- Sensitivity and selectivity are the core parameters of all receivers.
  - Excessive phase noise and/or IMD limit usable sensitivity and effective filter stopband attenuation.
- “Brick-wall” filters may be the ideal, but...
  - Processing time across filters increases latency.
  - A compromise must be struck between filter performance and latency.

# Issues in SDR testing:

## *direct-sampling SDR characterization*

- With the advent of fast, cost-effective ADCs, the direct-sampling SDR has eclipsed its QSD (quadrature-mixer) predecessors.
- This architecture poses new challenges to the test engineer:
- DR3 has no relevance as a performance metric.
  - DR3 increases with increasing test-signal power, reaches a peak at  $\sim -10$  dBFS (10 dB below ADC clipping) and then drops rapidly.
- IP3 (3<sup>rd</sup>-order intercept) is meaningless here, as IMD in an ADC follows a quasi-1<sup>st</sup>-order rather than a 3<sup>rd</sup>-order law.
  - The transfer and IMD curves diverge, and never intersect. In a conventional receiver, IP3 is the convergence point of the transfer and IMD curves.
- As the ADC clock is the only significant phase-noise source, a very-low-noise crystal clock oscillator almost eliminates reciprocal mixing noise. Unlike a conventional LO, the ADC clock's phase noise is independent of the receive frequency.
  - RMDR is so high ( $\gg 100$  dB) that even the very best crystal oscillators as test signal sources can degrade the measurement.
  - A notch filter whose stopband is centred on the test frequency can be inserted in the signal path to reduce the phase noise of the test signal.

# Improved RMDR Test Method

*using notch filter to improve accuracy*

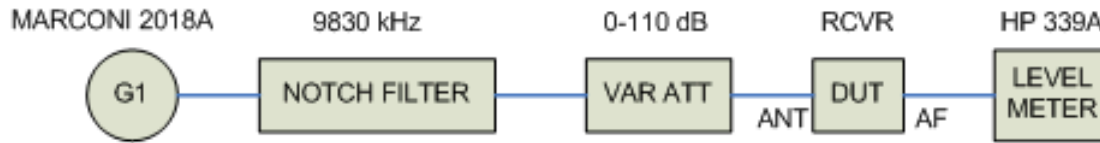

BLOCK DIAGRAM OF RECIPROCAL MIXING TEST SETUP

- Notch filter (notch at  $f_0$ , depth > 80 dB) between sig. gen. and DUT.
- $f_0$  = freq. of max. attenuation.  $\Delta f$  = offset.
- DUT tuned to  $f_0$ . Sig. gen. tuned to  $f_0 + \Delta f$ ; input power to raise audio output by 3 dB is noted.
- Notch filter suppresses sig. gen. phase noise at  $f_0$ , thus improving measurement accuracy.
- RMDR = input power – filter passband insertion loss – MDS.

# The IP3 Problem in an ADC

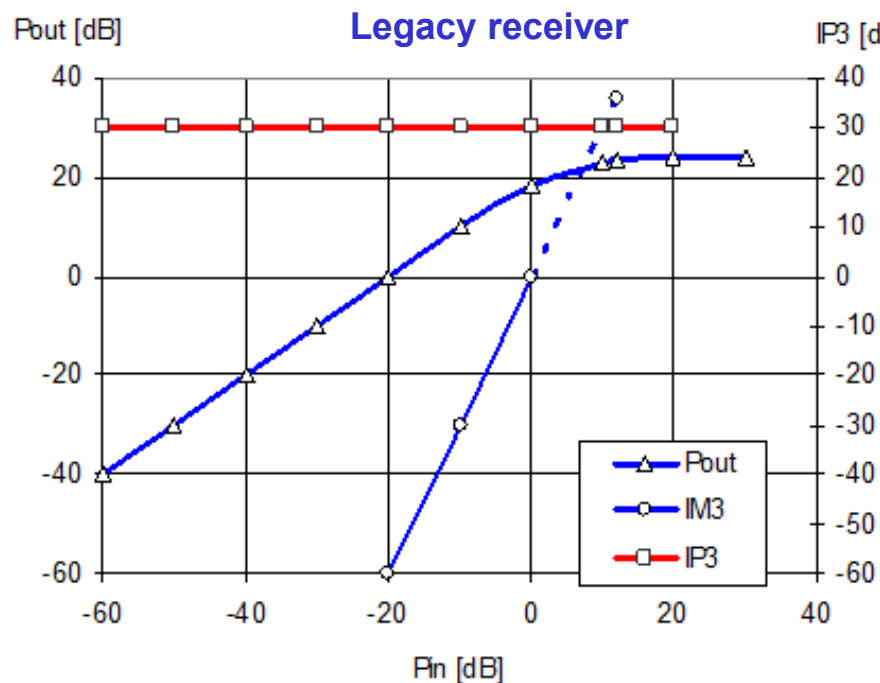

IM3 product increases 3 dB per dB of input power

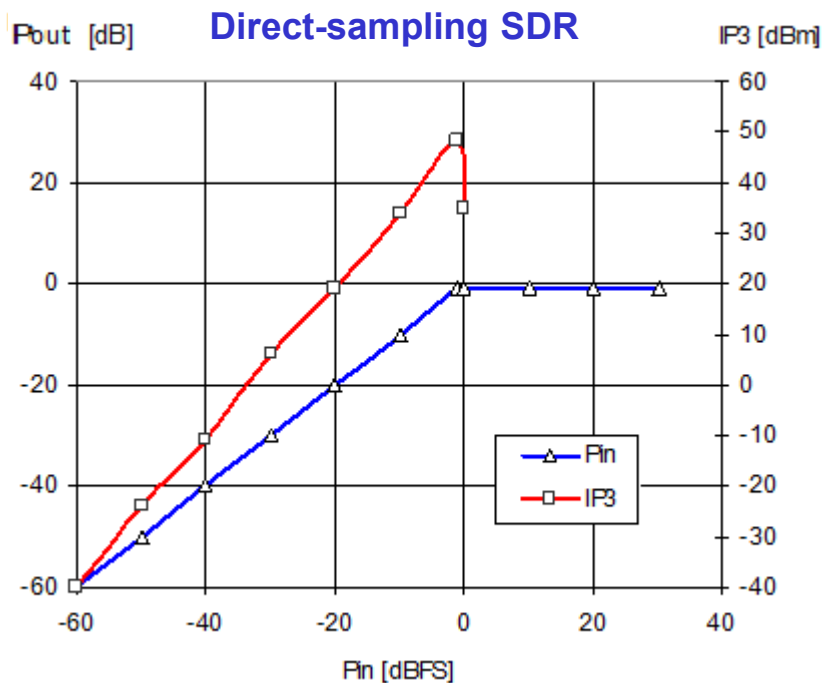

IM3 product is nearly independent of input power (0 dBFS = ADC clipping level)

# The DR3 Problem:

*Perseus SDR vs. legacy receiver*

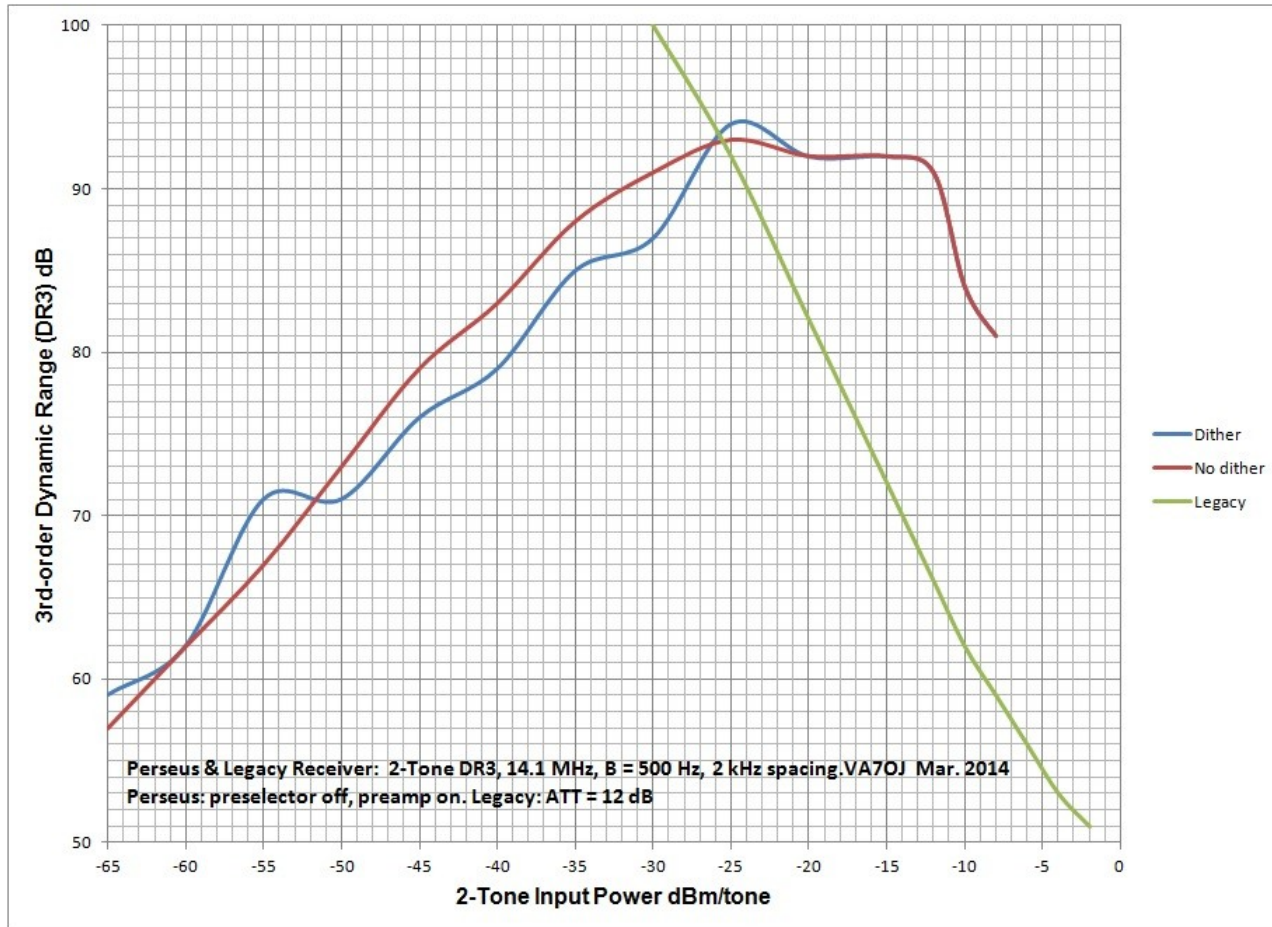
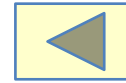

# The DR3 Problem:

## *discussion*

- The [chart](#) shows that the DR3 of a direct-sampling receiver is unusable as a predictor of dynamic performance.
- DR3 increases with increasing input power, reaching a *sweet spot* at  $\approx -10$  dBFS, then falling off rapidly as 0 dBFS (ADC clip level) is approached.
  - By contrast, DR3 of the legacy receiver decreases with increasing input power.
- A new method for specifying receiver IMD is proposed: measure the absolute power of interferers (IMD products and spurs) against 2-tone input power, with the ITU-R P.372 band noise levels for typical urban and rural sites at the frequency of operation as datum lines. We term this **IFSS** (interference-free signal strength).
  - If the interferer is below the band noise at the user site, the band noise will mask it and it will not be heard. Note that the P.372 band noise levels are typical; the actual noise levels will be site-specific.

# IFSS IMD Power Measurement

## *in a direct-sampling SDR*

- We measure the absolute amplitude of each interferer (IMD product or spur) and draw a [chart](#) of interferer amplitude vs. per-tone test signal power at a 500 Hz detection or IF bandwidth.
  - The ITU-R [P.372-2](#) band noise levels for typical rural and urban sites are shown as datum lines (-103 and -109 dB at 14 MHz, respectively.)
- **If the interferer is below the band noise, it can be *disregarded*.**
- The IFSS method eliminates the *sweet spot* problem in DR3 measurements on SDR's.
- **On our direct-sampling SDR, we can read the observed IMD product and interferer levels directly off the S-meter or spectrum scope.**
  - The scope and S-meter level calibration should be checked before taking these readings.
  - **A preamp and/or active ADC driver ahead of the ADC will degrade IMD.**
  - Note that the IFSS curve is quasi-1<sup>st</sup>-order until non-linearity in active stages ahead of the ADC introduces 3<sup>rd</sup>-order effects.



# Typical 2-Tone IMD Test Setup

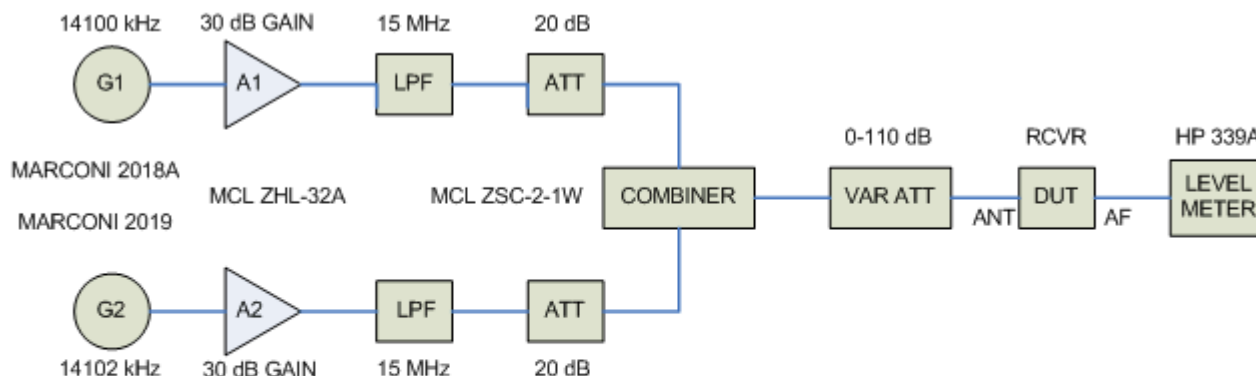

BLOCK DIAGRAM OF TYPICAL TWO-TONE RECEIVER TEST SETUP

- Test signal power is adjusted for desired IMD product level as read on spectrum scope/S-meter (IFSS) or for 3 dB increase in audio output level (DR2).
- Amplifiers A1, A2 buffer the signal generators G1 and G2 to block RF sneak paths across the combiner. This prevents mixing in the generators' output stages (a cause of IMD).

# ITU-R band noise levels

(Courtesy ARRL)

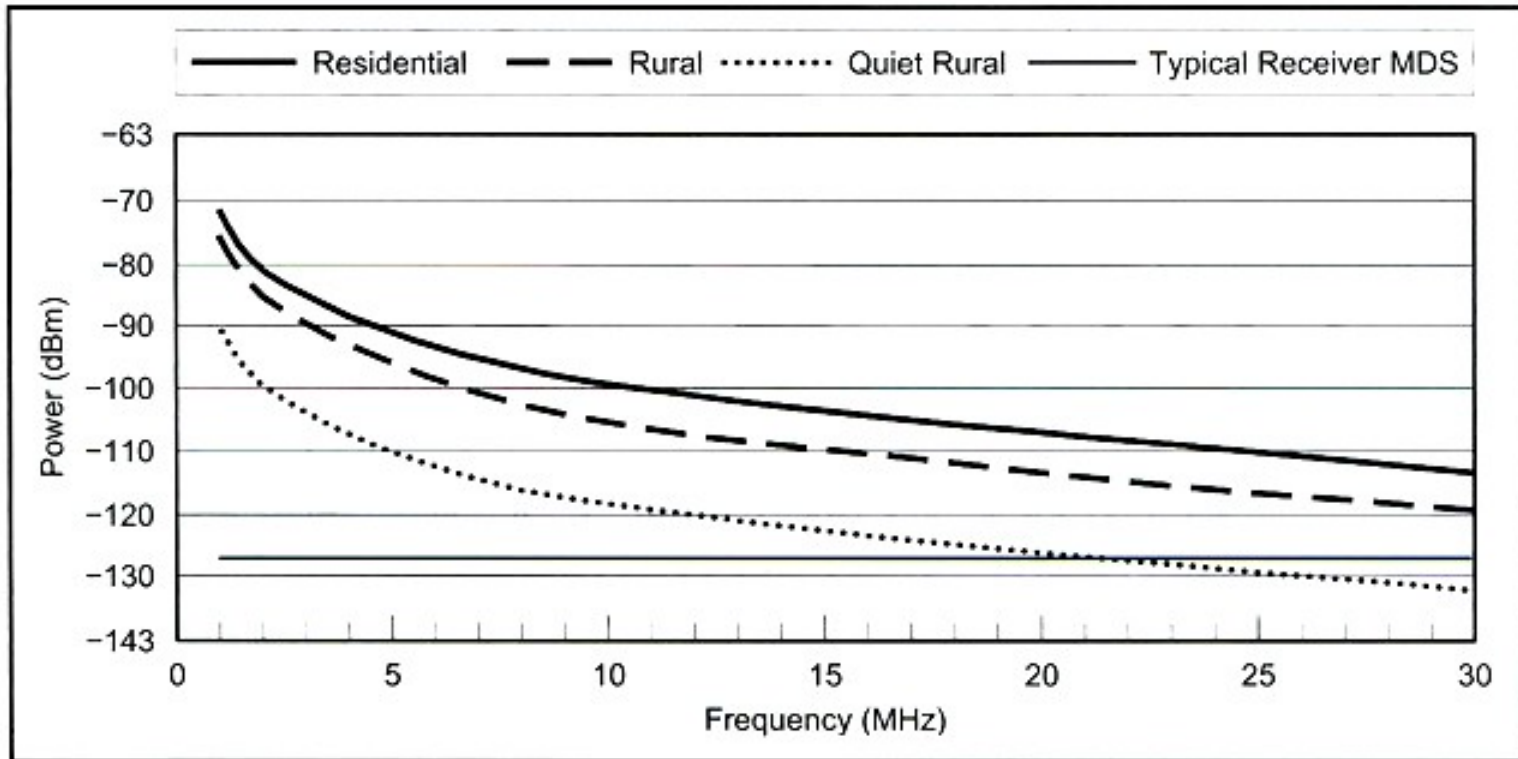

Typical noise levels versus frequency for various environments.  
(Man-made noise in a 500-Hz bandwidth, from Rec. ITU-R P.372.7, *Radio Noise*)

# IMD vs. input power (IFSS):

*Typical direct-sampling SDR (Perseus)*

For the Perseus, the IMD curve is  $\approx 1^{\text{st}}$ -order until  $-25$  dBm input level, then rises rapidly to  $3^{\text{rd}}$ -order due to IMD in active stages ahead of ADC.

Note the effect of dither on the IFSS curve.

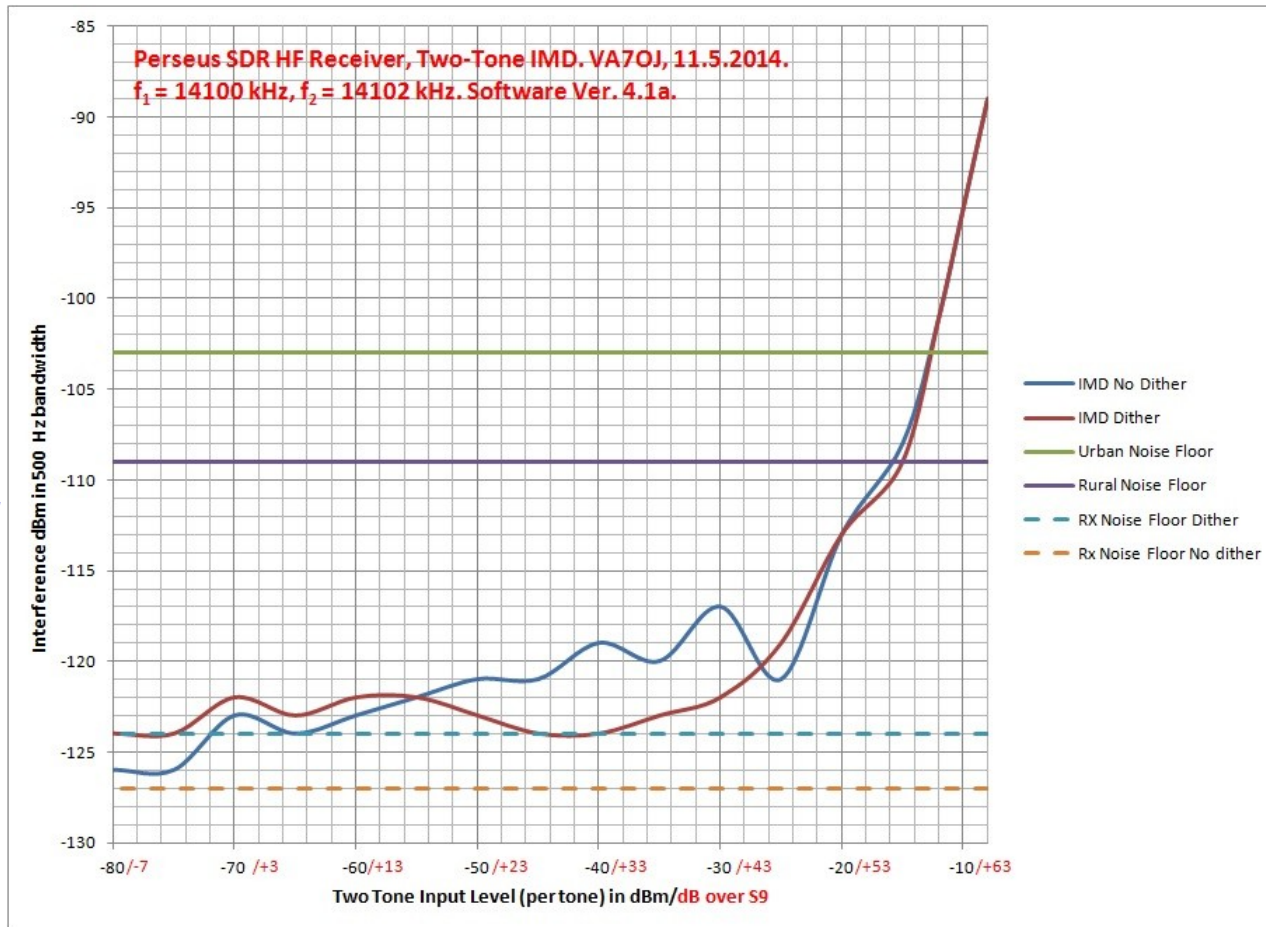

# Other considerations for HF SDR receiver testing

- The measurement of second-order IMD dynamic range (DR2) is still useful in SDR testing, as 2nd-order mixes in active stages ahead of the ADC can cause HF BCI.
  - Example: 6 & 8 MHz interferers throw product on 14 MHz.
- Image rejection and IF leakage measurements are not applicable to direct-sampling SDR's, but an aliasing rejection test is useful.
  - Inject a signal in Nyquist Zone 2 ( $f > f_s/2$ ) and measure amplitude of product in Nyquist Zone 1 ( $f < f_s/2$ ). Lower alias product = better anti-aliasing filter.
- The noise-power ratio (NPR) test is a useful tool for identifying impairments in SDR and conventional receivers.
  - Originally used to characterise analogue multi-channel transmission systems in the telecom network, NPR testing has been adapted for stress testing of HF receivers.
  - If a complete NPR test set (noise generator and noise receiver) is available, it can be used also for testing 2-port networks (amplifiers, wideband transformers, filters etc.) This test will detect passive IMD (PIM) in passive components.

# NPR & Aliasing Test Screens

Perseus,  $f_0 = 5340$  kHz  
Noise loading -1 dBFS  
Detection BW = 2.4 kHz  
Preselector on, dither off  
ATT = 0 dB, Preamp off  
Software: V4.1a

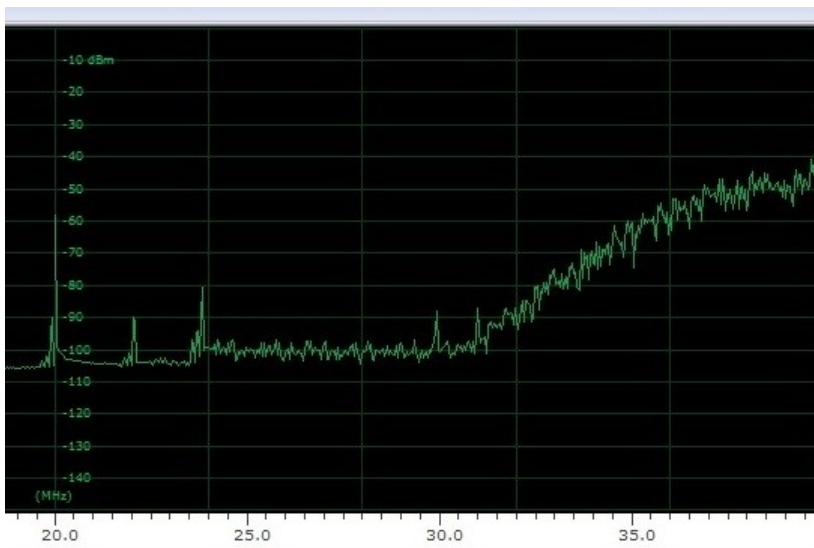
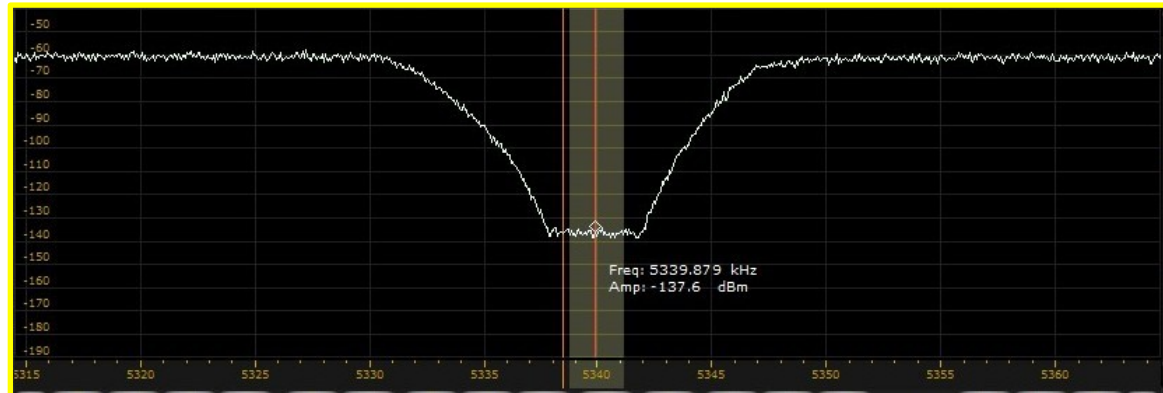

Perseus,  $f_s/2 = 40$  MHz  
Sweep range 40...50 MHz  
Input level -20 dBm  
Preselector off (default)  
ATT = 0 dB, Preamp off  
High Gain off, dither off  
Window: Blackman  
Avg. 256, Span 40 MHz  
Aliasing trace 30-40 MHz

# Noise Power Ratio (NPR) Testing

- Wideband Gaussian noise from a noise generator is applied to the receiver input. This *noise loading* provokes added noise in the receiver due to IMD and reciprocal mixing.
- Added noise power is a measure of overall receiver performance.
  - Less added noise = better receiver. *A perfect receiver will add no noise at all.*
- A notch (bandstop) filter just wider than the receiver's detection bandwidth is placed at the noise generator output. Notch depth  $\geq 90$  dB.
  - The receiver is tuned to place the detection passband in the centre of the notch.
  - A band-limiting (bandpass) filter ahead of the notch filter defines the applied noise bandwidth.
  - Ideally, only the added noise generated by the receiver's impairments will appear in the detection passband.
- NPR = noise power in a channel equal in bandwidth to the detection passband, but outside the notch  $\div$  noise power in the detection passband.
  - The theoretical maximum NPR can be calculated for a given ADC and used as a performance datum point. If measured NPR  $\ll$  theoretical NPR, this may indicate PIM in the RF front end.

# W&G RS-50 NPR Noise Generator

*Upper filters: Band-limiting (Bandpass). Lower filters: Notch.*

Owned by author

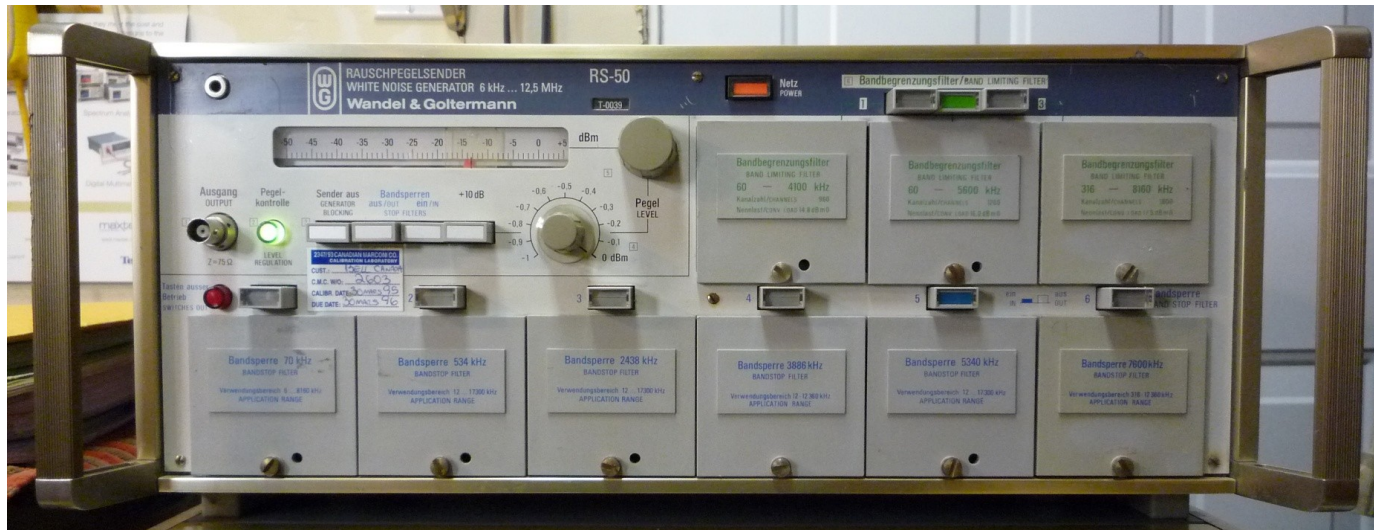

# Latency Testing

## *(Receiver and Transmitter)*

- Latency (signal transit time from RF input to audio output) in an SDR is a function of real-time processing power, and is directly affected by DSP filter parameters.
  - Latency is of critical importance in high-speed CW operation (especially QSK), and also in the digital modes.
  - Latency > 100 ms can also degrade voice operation, especially fast back-&-forth with VOX, and can render the Monitor function almost unusable.
- A compromise must be struck between filter shape factor and latency.
- Receiver latency is measured by applying a pulse train with fast rise-time to the RF input and measuring the time interval between the applied pulse (at the RF input) and the received pulse (at the audio output) with a 2-channel oscilloscope.
- CW transmitter latency is measured by keying the transmitter with dits and measuring the time interval between the leading edge of the keying signal and that of the transmitted dit (at the RF output) with the oscilloscope.
  - Voice (e.g. SSB) transmitter latency is measured by applying a 1-cycle burst of test tone to the mic input and measuring the time interval between the leading edge of the burst and that of the transmitted signal (at the RF output) with the oscilloscope.



# Typical Filter Shape Factor/Latency Curves

(ANAN series, PSDR OpenHPSDR mRX v3.3.7)

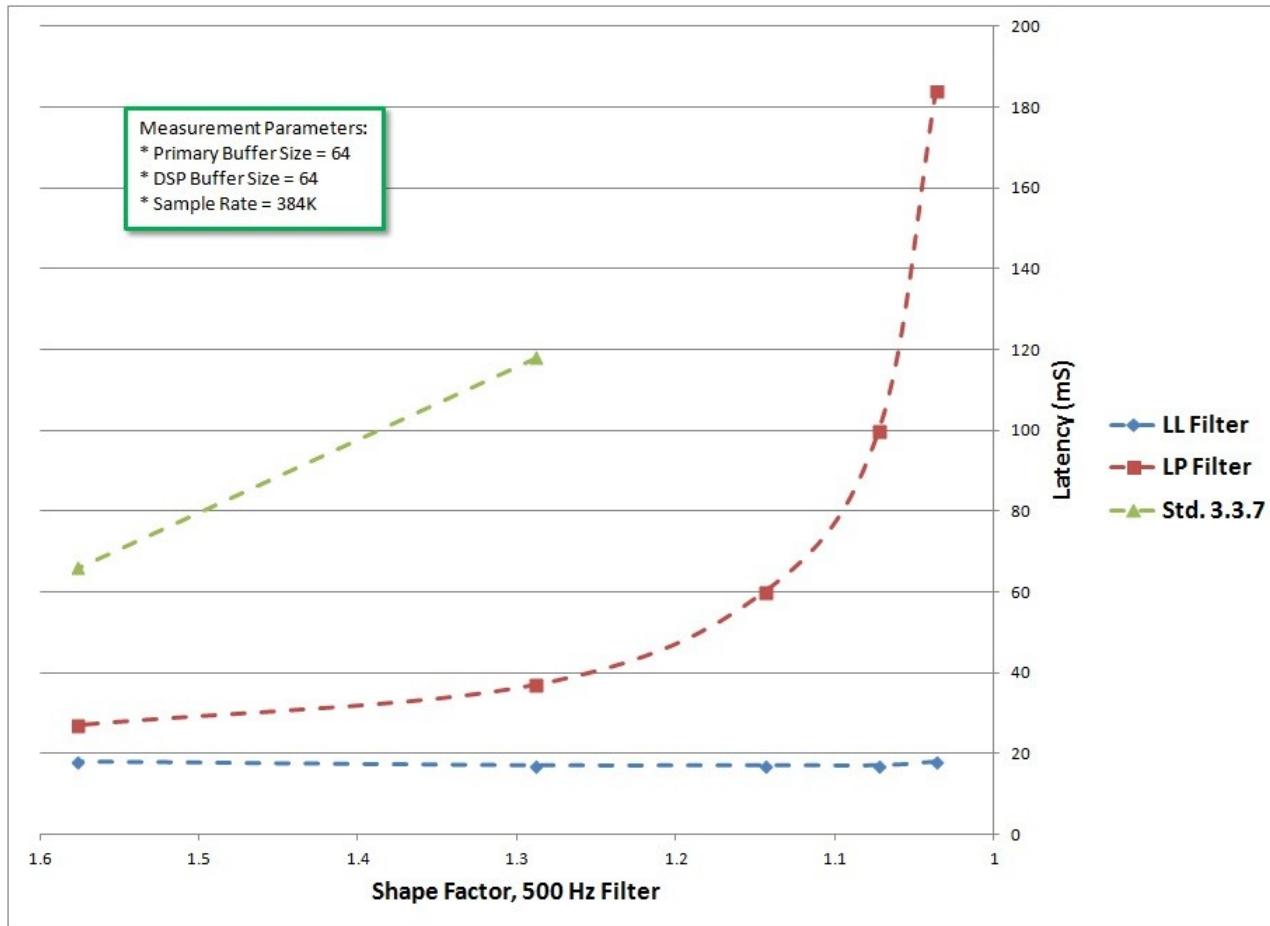

LL: Low Latency. LP: Linear Phase. LP is provided as a user option. Std. 3.3.7 does not have these options.

# References for further study

1. <http://www.itu.int/rec/R-REC-P.372/en>
2. <http://tinyurl.com/testproc2011> (*ARRL Test Procedure Manual, 2011*)
3. <http://www.nsarc.ca/hf/npr.pdf>
4. <http://www.nsarc.ca/hf/rcvrtest.pdf>