

-. - . - - . - - . . . . - . - - . . . - . . . . .

# German WW2 Radio

technology, equipment & innovations

Adam Farson  
VA7OJ



# Scope of presentation



- **Component and packaging technology**
- **Design features**
  - ◆ **Frequency stability & repeatability**
  - ◆ **Maintainability**
- **Typical components**
- **Luftwaffe: MF/HF & VHF communications**
- **Joint Service: E52 'Köln' HF Receiver**
- **Wehrmacht: Portable VHF Tactical Radio**

# Highlights of German WW2 military radio



- German radio industry (1930 – 1945) was extremely innovative
- Many advances in component, circuit & system design are still in use today
- Particular strengths in vacuum tubes, receivers and airborne radio systems
- Mechanical construction & packaging generally superior to comparable Allied equipment
- Pioneered deployment of tactical VHF comms (*and even SSB in fixed installations*)

# Component and packaging technology



- Use of as few tube types as possible
  - ◆ Simplify manufacture and logistics, but complicate circuit design
- US control of Brazilian quartz markets influenced design:
  - ◆ Simple MOPA-type transmitters
  - ◆ Limit use of quartz crystals to IF filters
  - ◆ Stable tunable oscillators became a fine art
  - ◆ Coils on ceramic formers with silver windings vacuum-deposited onto grooves in former.  $Q > 500!$
  - ◆ IF coils on powdered-iron pot-cores
  - ◆ Temp. coefficient of ceramic compensated for that of metallic windings; also NTC and PTC ceramic capacitors
  - ◆ Precision tuning capacitors; plates machined from single billet on ceramic shaft
  - ◆ Solid die-cast light-alloy chassis; heat-producing components thermally coupled to chassis [Link](#)

# Design for frequency stability & repeatability



- Large, directly-calibrated tuning dials
  - ◆ resolution to 100 Hz
  - ◆ precision backlash-free dial drives
- Crystal calibrators in some sets
  - ◆ also portable, plug-in calibrators
- Dynamic compensation of transmitter MO (VFO)
  - ◆ RF current & TC/loss factor of capacitor adjusted such that key-down RF heating of capacitor offsets drift due to RF heating of coil and heat-related inter-electrode capacitance changes in MO tube
- Typical stability:  $\pm 3.2 \times 10^{-4}$  ( $\pm 1.3$  kHz at 4 MHz)
  - ◆ for -50 to +50°C, 22 to 29V DC supply voltage range
- This technology was lost in the post-war years
  - ◆ synthesizers removed incentive for its retention

# Design for maintainability



- **3-dimensional construction**
  - ◆ compartmentalized die-cast light-alloy chassis, with each functional circuit in its own shielded compartment wherever possible
  - ◆ tubes in recessed sockets, removable from chassis exterior
- **Compact modular design, with standard interfaces**
  - ◆ inter-modular connectors allowed easy assembly and disassembly
- **Logical breakdown: “block diagram in hardware”**
  - ◆ RX: RF/mixer, LO, IF & selectivity, demodulator, AF
  - ◆ TX: MO, buffers if any, PA, output tank, T/R switching
    - ▶ AM modulator separate
- **Testability**
  - ◆ each module tested individually on special test jigs prior to integration and final test
  - ◆ “BITE”: in-circuit tube check with built-in meter or plug-in test set

# Typical components



- **RV12P2000 Pentode:** widely used as small-signal RF, IF and AF amplifier etc. This is the **only** tube type used in the FuG 10 EK and EL receivers, and in the Telefunken E52 'Köln' HF receiver.

- **Variometer:** variable inductor used in FuG10 airborne MF/HF transmitter.  $L_{\min}$  with coils  $90^\circ$  apart. Note sputtered-on windings.
- Image courtesy G3YNH.

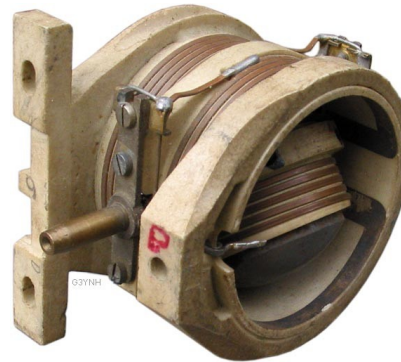

- **RL12P35:** Transmitting pentode used as PA and driver in many radio systems incl. FuG 10. 35W anode dissipation.



- Here are a few examples of components used in German WW2 radio equipment.

# FuG 10 (Funkgerät Typ 10)

## Luftwaffe MF/HF radio system



- **Developed by Lorenz AG (now Alcatel-SEL), 1936-37**
  - ◆ standardized in 1939 for all larger aircraft with crew > 2
  - ◆ RAF equivalent was T1154/R1155; US equiv. was BC-375/BC-348
- **Plug-in modular component units on flight deck**
  - ◆ EK (HF) & EL (MF) receivers [Link 1](#) [Link 2](#)
  - ◆ SK (HF) & SL (MF) transmitters [Link 3](#)
  - ◆ Antenna control unit (FBG.3), modulator (TZG 10), switchbox etc.
- **Remote ATU (AAG.2) – mounted in tail area, near antennas**
  - ◆ Controlled from FBG3 via synchros, connected to TX/RX via 60Ω coax
- **Basic specifications: [Link 4](#)**
  - ◆ Freq. range: MF 300 - 600 kHz. HF 3000 - 6000 kHz.
  - ◆ Power output: 70W (A1A), 40W (A2A, A3E)
  - ◆ Sensitivity: 4 μV for 10V<sub>rms</sub> output in 4 kΩ (A1A)
  - ◆ Selectivity: 6 dB BW = 3 kHz, 60 dB BW = 18 kHz
  - ◆ Primary DC power input: 800W max.



# FuG10 Overall System View

## Module Dimensions:

RX: 180mm H X 200mm W X 220mm D

TX: 220mm H X 215mm W X 200mm D



- Upper row: MF RX (EL), HF RX (EK), Antenna Control Unit (FBG.3)
- Lower row: MF TX (SL), HF TX (SK), Switchbox
- 2 antennas: fixed or trailing-wire, selectable at FBG.3. Trailing antenna is remote-controlled (12m HF, 70m MF).
- 60Ω coax between TX/RX and remote ATU. Vacuum T/R relay in ATU.

# FuG10 Interior Views



**SK Transmitter** with RL12P35 tubes  
(1 in MO, 2 in parallel for PA)  
Image courtesy LA6NCA

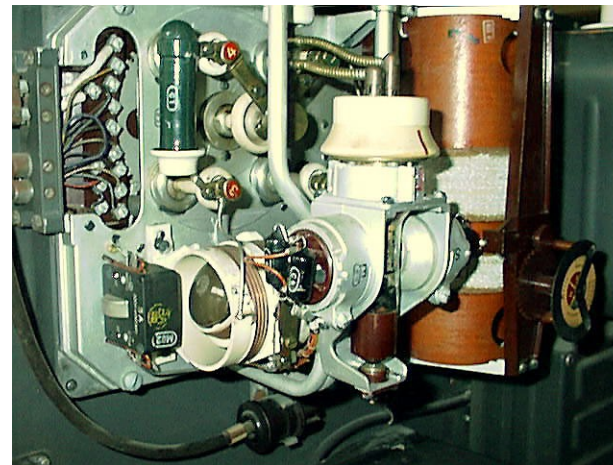

**AAG.2 ATU** showing HF variometer (left),  
vacuum T/R relay (centre) and MF  
variometer (right). Image courtesy SRS

- **Note the extremely high quality and finish.**

# FuG10 Interior Views



**EK Receiver**, top view, showing tube sockets, IF transformers and chassis compartments.  
Image courtesy Bo Samuelsson



**EK** front panel frame & tuning dial mechanism with 4 preset cams.  
Image courtesy LA6NCA

**EK**: Detail of main tuning capacitor.  
Image courtesy LA6NCA

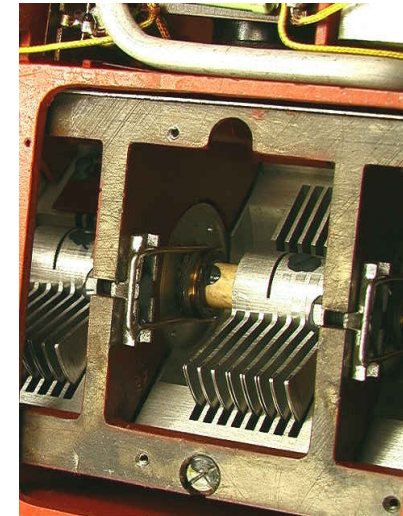

- **Note the extremely high quality, precision and finish.**

# Basic Schematic of E 10 L MF Receiver (300 - 600 kHz)

Source: Fritz Trenkle



**Note:** No AGC in E 10 L. Later HF RX E 10a K had AGC circuit.

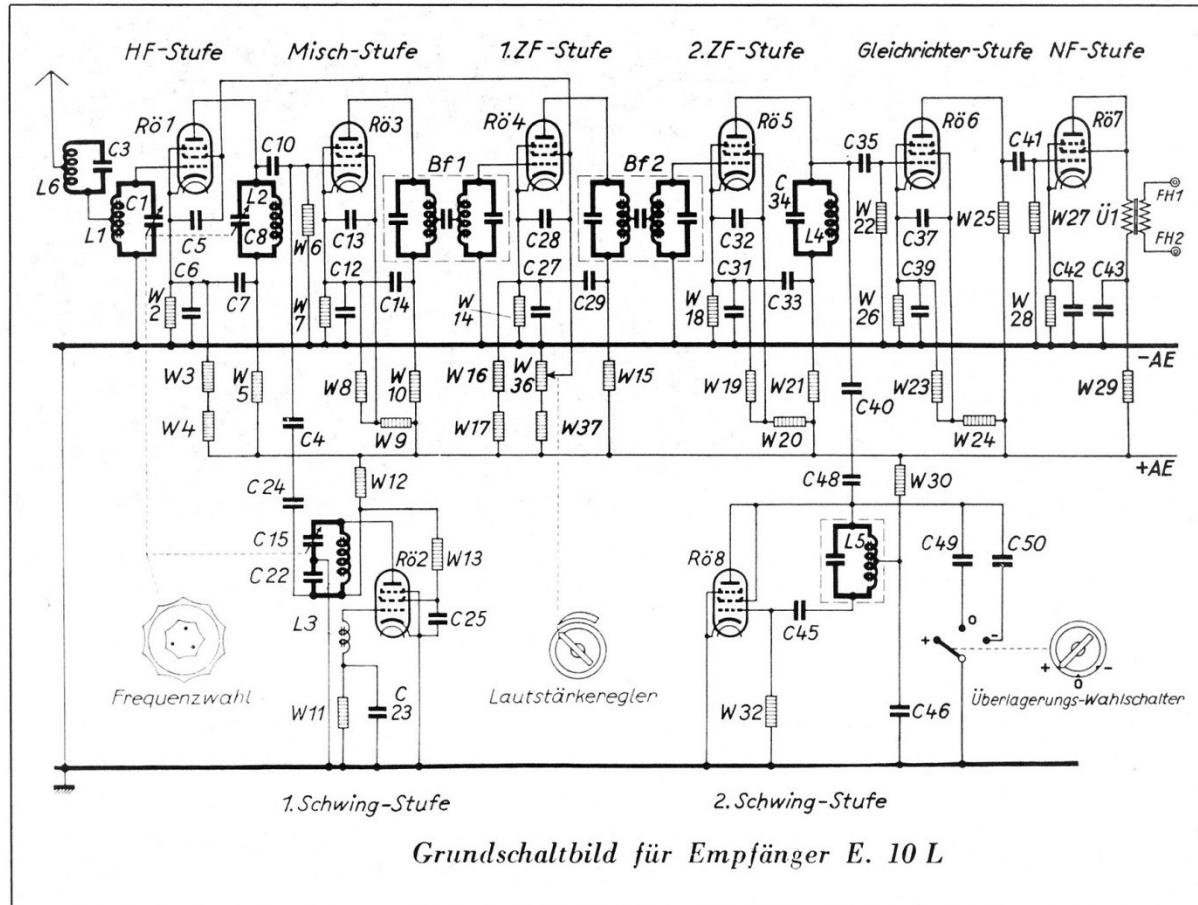

# Basic Schematic of E 10a K HF Receiver (3000 - 6000 kHz)

courtesy Bo Samuelsson



Note: R610 is AGC circuit. "10a" denotes AGC.

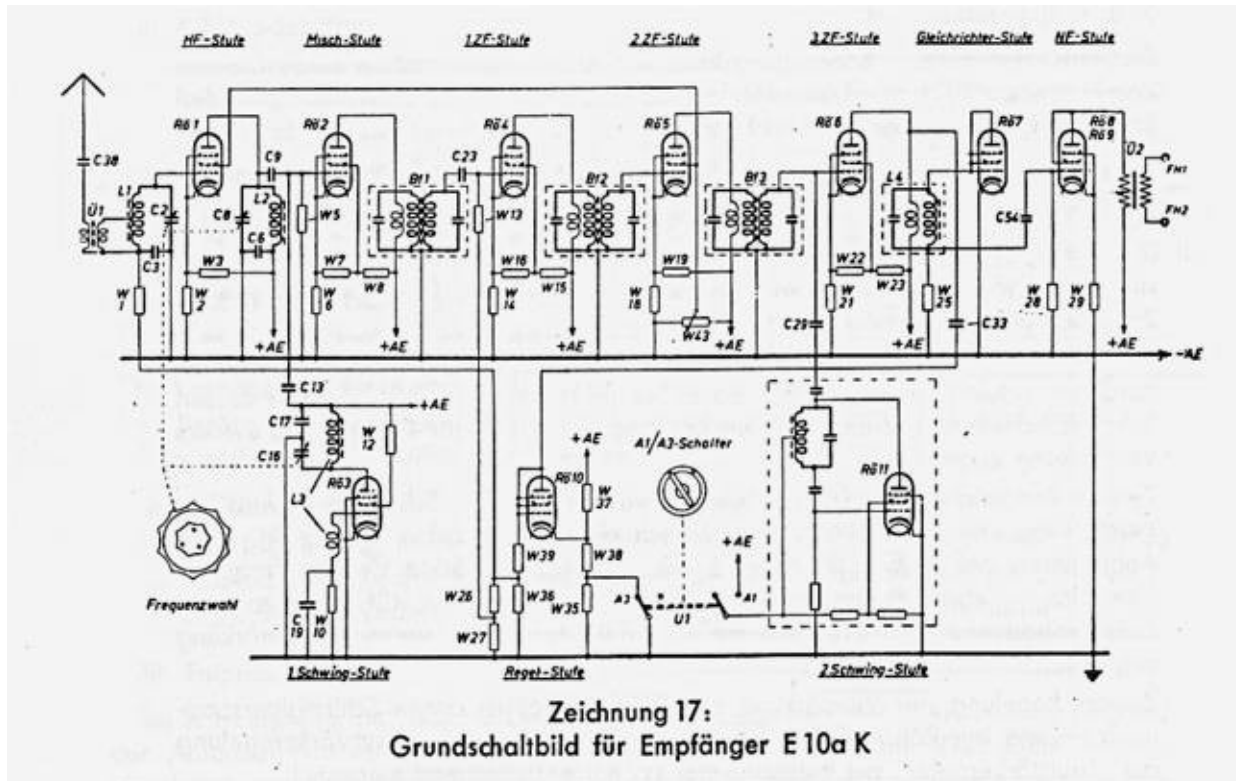



# Telefunken E52b 'Köln' HF

## Receiver - the most advanced RX of its era

Image courtesy Bo Samuelsson



[Link 1](#) [Link 2](#)

# E52 'Köln' HF Receiver

Interior View (courtesy Bo Samuelsson)

Modules (l-r): mixer/LO (shield removed), RF 2, RF 1

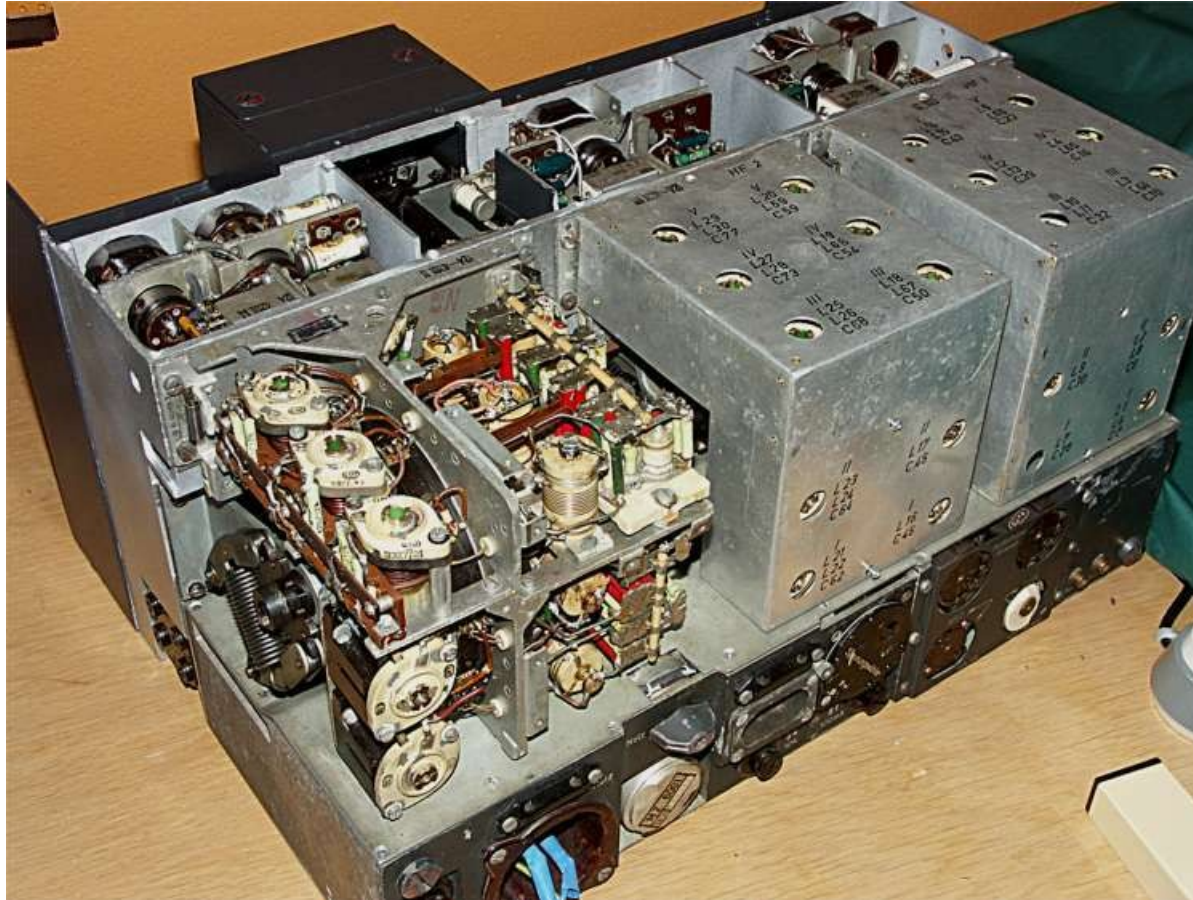



# E52 'Köln' HF Receiver

Interior Details *(courtesy LA6NCA)*

1

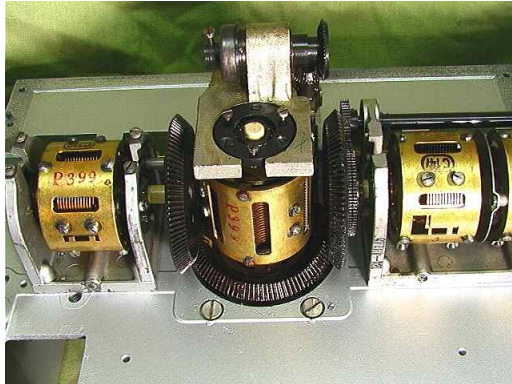

2



3

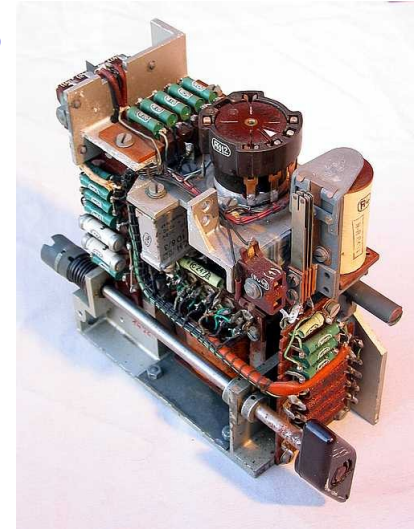

4



- 1 Tuning capacitor detail
- 2 IF/crystal filter module
- 3 AF amplifier module
- 4 Mains/12V PSU module

# E52 'Köln' HF Receiver

## Module Details *(courtesy Bo Samuelsson)*

1

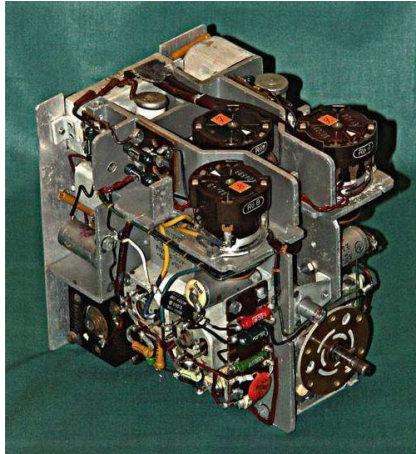

3

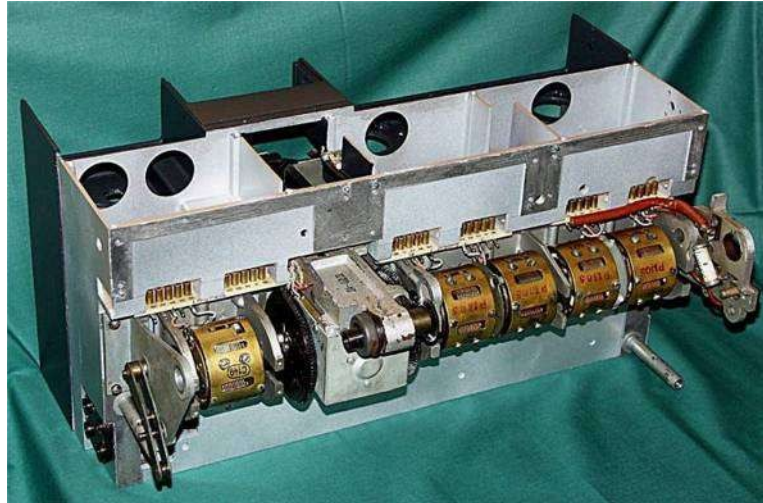

- 1 IF/crystal filter module
- 2 BFO module
- 3 Main tuning capacitor
- 4 Tuning dial detail

2

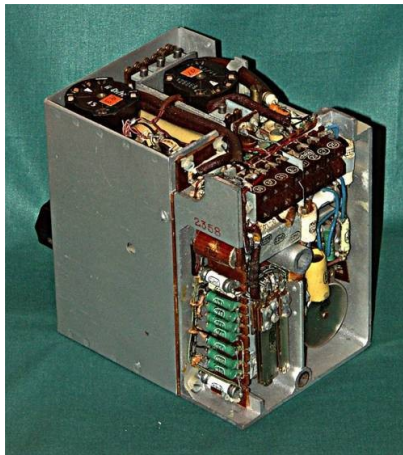

4



# E52 'Köln' HF Receiver



## ■ Single-conversion HF superhet communications receiver

- ◆ Developed 1941 by Telefunken for Luftwaffe; adopted later by all services. Used by German merchant marine until early 1960's
- ◆ 5-pole active tunable RF preselector with 2 RF amps: superb image rejection, IF rejection, front-end protection and sensitivity
- ◆ 1 MHz IF; crystal filter with continuously-variable bandwidth
- ◆ Supported emissions: A1A, A2A, A3E
  - ▶ [SSB/ISB adapter](#) available for J3E, B8E
- ◆ Die-cast chassis with shielded modules plugged into backplane
- ◆ Unique precision geared tuning mechanism with optical projection readout (window above main dial). Resolution 1 kHz
- ◆ Motorized tuning drive on E52a version, omitted on E52b
- ◆ AGC on all RF and IF stages
- ◆ Crystal-controlled BFO with +900 Hz offset
- ◆ Built-in power supply for AC mains and 12V DC operation

# E52 'Köln' HF Receiver

## Block Diagram (courtesy LA6NCA)

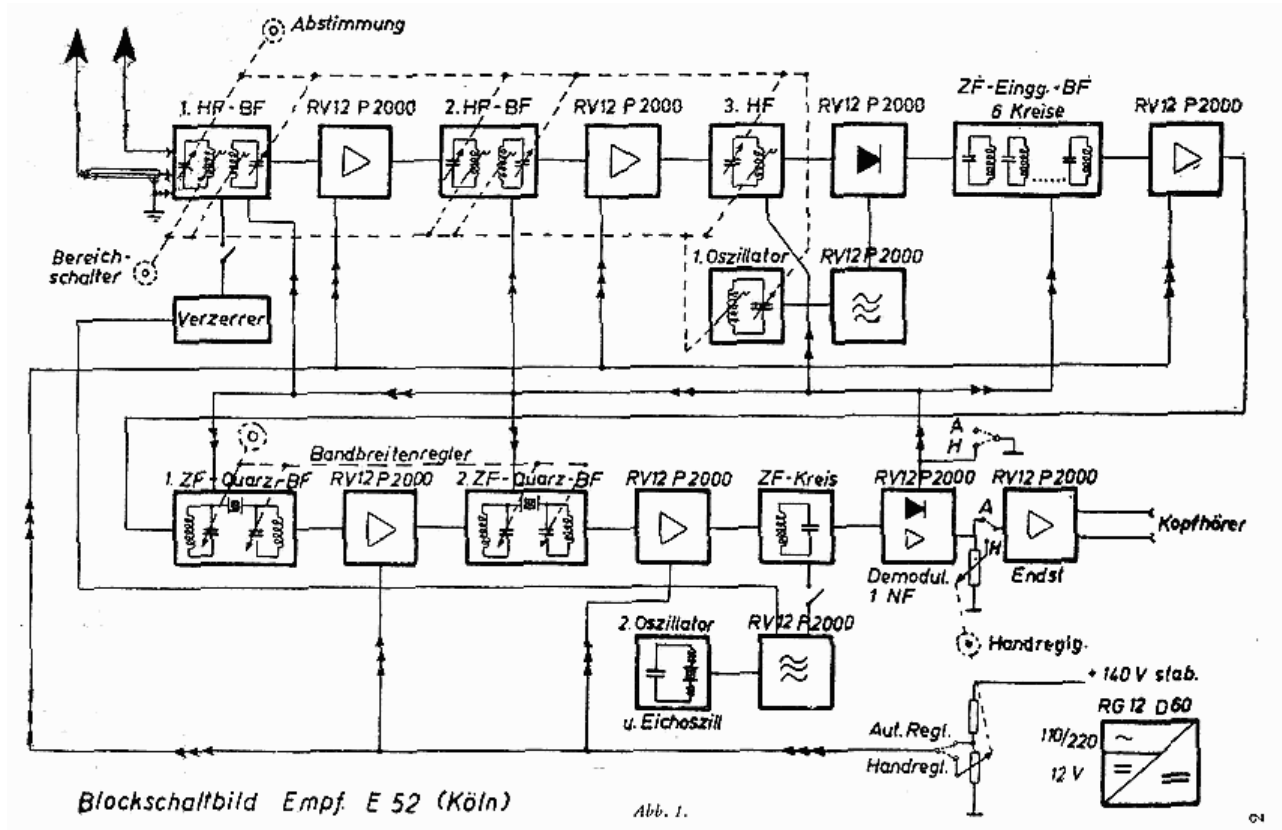

# E52 'Köln' HF Receiver

## Technical Specifications



- **Frequency ranges:** 1.5 – 3 MHz, 3 – 6 MHz, 6 – 10 MHz, 10 – 17.7 MHz, 17.6-25.2 MHz
- **Modes:** A1A, A2A, A3E. Optional F3E, J3E, B8E
- **Power requirement:** 110-230VAC 50-60Hz, or 12VDC
- **Dimensions:** 245 x 446 x 350 mm
- **Weight:** 40.8 kg
- **Sensitivity:** A3E (wide) 3.5 $\mu$ V; A1A (wide) 1 $\mu$ V; A1A (narrow) 0.3 $\mu$ V
- **Image rejection:** > 94dB at 20MHz
- **IF rejection:** > 100dB at 1.5 MHz
- **Antenna inputs:** 60/150  $\Omega$
- **IF:** 1000 kHz
- **BFO:** 1000.9 kHz
- **Bandwidth:** continuously variable from 10 kHz (-3dB)/*26 kHz (-60dB)* to 200 Hz (-3dB)/*4 kHz (-60dB)*
- **Frequency stability:** < 30 x 10<sup>-6</sup> per °C
- **Tuning dial resolution:** 1 kHz

# Mobile VHF Tactical Radio



- German and Dutch radio industries had found VHF line-of-sight (LOS) propagation ideal for urban mobile radio comms. [Link](#)
- This led to VHF R/T systems in the 27 - 55 MHz band – rapidly adopted by Wehrmacht and Luftwaffe in late 1930's.
  - ◆ "Equipping armoured troops with VHF radio enabled individual units to be tied into the command network. The control over fast-moving combat forces gave the army operational advantages."
- Tactical VHF radio was the “central nervous system” of the Blitzkrieg
  - ◆ Allowed integrated command and control of infantry, armour and close air support
- Mobile VHF transmitters had 10 to 15W output
  - ◆ portables such as "Kleinfunksprecher d" (1944) had 0.25 to 0.5W output [Link](#)
- Frequency ranges 20 - 33 & 30 - 55 MHz; A3E emission (AM)
  - ◆ US Army deployed 27 - 55 MHz F3E (FM) tactical radio only in late 1943/early 1944
- British Army resisted VHF adoption almost until war's end
  - ◆ “NIH factor” and concerns about LOS propagation in congested areas were obstacles
  - ◆ Low-power AM radio sets in 2 – 4 MHz range with short antennas contributed to disastrous comms. breakdowns (e.g. “Market Garden”)

# Portable VHF Tactical Radio: *Kleinfunksprecher d "Dorette"*

*image & data courtesy LA6NCA*



## **KIFuSpr.d Specifications**

Frequency range: 32 – 38 MHz  
Power output: 200 mW  
Power input: 1.4V, 150V  
Battery life: 25 hrs. (80% RX, 20% TX)  
Antenna: Tape antenna, 1.6m long  
Tubes: Two RL 1 P 2, one DDD25  
Size, transceiver: 130 x 70 x 200 mm  
Size, battery box: 110 x 100 x 170 mm  
Weight, transceiver: 1.6 kg  
Weight, battery box: 1.5 kg

# Portable VHF Tactical Radio: *Kleinfunksprecher d "Dorette"*

images courtesy LA6NCA



Above: Interior view, showing tuning dial  
Left: Side view. Note tuning dial window



# Future Presentations on German WW2 RF Topics



- **COMINT/SIGINT:** Intercept receivers & test equipment (*e.g. spectrum analyzers!*)
- **ECM:** Comms and radar jamming, ECCM
- **Radar systems:** Ground, airborne and naval

# Links for further study



- • — • — — • — — • • • — • — — • • • — • • • • — •
- [Helge Fykse LA6NCA Website](#)
  - [Bo Samuelsson's Vintage Radio Site](#)
    - ◆ *Sincere thanks to Helge and Bo for graciously allowing me to use their superb photos*
  - [LA8AK Radio Communications Resource Page](#)
  - [Foundation for German Communications](#)
  - [VA7OJ/AB4OJ Military Radio Page](#)
    - ◆ Also see [Military Radio Links](#)