

DXP-3 DXpedition Phasing Unit

Mark Connelly, WA1ION - 26 SEP 2000; updated 9 OCT 2003

INTRODUCTION

The DXP-3 is the most compact of several phasing units designed for DXpedition use. Chassis size is 5.25 x 2.92 x 2.125 in. (13.34 x 7.42 x 5.4 cm). For previous models, see DXP-1 [*reference 1*] and DXP-2 [*reference 2*]. As noted in other articles, the object of phasing units is to combine the contributions of two antennas at a 180 degree phase relation in order to null out a dominant signal (or noise) and let otherwise-inaudible weaker co-channel and adjacent channel signals come through.

DXP-3 is optimized for medium wave (500 to 2000 kHz) operation, though it may also perform reasonably well on the longwave and tropical band shortwave frequency ranges.

Phase shifting is wideband in nature: tuning is not required. In high-signal urban areas, one could benefit from passive L-C preselection on each of the two input lines ahead of the unit. In most cases, this isn't necessary.

With broadband phasing, a null set up in a given direction is often effective plus or minus 100 kHz or more from the set-up frequency.

The DXP-3 allows independent observation of each input line as well as providing two combined signal (null) positions. This enables the user to balance amplitudes accurately, at least if the receiver has an S-meter, before adjusting the phase for a null. For good null depth, each of the two input lines must have a similar strength of the signal to be nulled.

OPERATING THE DXP-3

Practicing on stable daytime medium wave groundwave signals is the best way to become familiar with the unit's operation. When starting out, choose a frequency having some evidence of a second station under the dominant one.

Initial set-up:

Connect a passive (unpowered) antenna to J1, or connect an active antenna (such as an MFJ-1024 whip) to J3.

Connect the second antenna to J2 (if passive) or J4 (if active).

Connect a DC power source of +12 volts (min.) to +18 volts (max.) to J6.

Connect the receiver, via coaxial cable, to J5.

Set R1 and R2 fully clockwise.

Amplitude Balancing:

Set R3 to center.

With S1 on 1, observe the level of the dominant signal (or noise) to be nulled. Also do this with S1 on 2.

If the signal level had been greater in the S1 = 1 position, adjust R1 so that the signal level measured with S1 on 1 is equal to that obtained with S1 on 2.

Conversely, if the signal level had been greater in the S1 = 2 position, adjust R2 so that the signal level measured with S1 on 2 is equal to that obtained with S1 on 1.

Nulling:

Set S1 to Null-a and adjust R3 for the best reduction of the dominant signal to be removed. Also do this R3 adjustment with S1 set to Null-b. Leave S1 on the null position which gave the deeper, better-defined null.

Finish up the null by small interactive adjustments of R3, R1, and R2.

Occasionally it may help to set R1 and R2 "fully clockwise minus 1 hour" (e.g. pointers at "4 o'clock" if fully clockwise is "5 o'clock") and then go back to the "Amplitude Balancing" section and proceed forward from there.

DXP-3A

This is an altered version of the DXP-3. It does not have active antenna inputs and the passive inputs use isolated-ground connectors (Mouser part number 523-31-10-RFX or equivalent) for implementation of low-noise grounding schemes. File "dxp3a.zip" [*reference 3*] contains the schematics of this design variation.

REFERENCES CITED

Links to Internet based references may change over time. If a specified link does not work, articles may still be accessible by contacting me directly so I can mail a disk of the article or suggest an updated Web link. Also, in some cases, articles may be available in "hard copy" from the National Radio Club reprints service.

[1] DXP-1

web = <http://members.aol.com/MarkWA1ION/dxp1.pdf>

[2] DXP-2

web = <http://www.qsl.net/wa1ion/dxp/dxp2.pdf>

[3] DXP-3A (zipped schematic files only)

web = <http://www.qsl.net/wa1ion/dxp/dxp3a.zip>

DXP-3 CONSTRUCTION DATA

Table HL-DXP-3: DXP-3 hole-drilling list

X = Horizontal distance, in inches, from the vertical centerline (VCL) on the side observed. Negative values of X are left of VCL, positive values of X are right of VCL.

Y = Vertical distance, in inches, from the bottom horizontal edge of the side observed.

D = Hole diameter in inches.

Hole loci are first marked on the box with a scribe and are then drilled with a .125" or smaller bit. Subsequently, as required, the holes are enlarged to the proper size by using progressively larger bits up to that corresponding to the final desired diameter.

Chassis Box = Radio Shack # 270-238: 5.25" X 2.92" X 2.125"

LEFT SIDE

<u>Hole #</u>	<u>Comp. Desig.</u>	<u>Description</u>	<u>X</u>	<u>Y</u>	<u>D</u>
1	J3	Line 1 Active Ant.In (BNC-f)	-0.875	1.0625	0.375
2	J1	Line 1 Passive Ant. In (BNC-f)	-0.625	0.4375	0.375
3	G1	grounding H/W - int.&ext.lug	0	0.4375	0.125
4	J2	Line 2 Passive Ant. In (BNC-f)	0.625	0.4375	0.375
5	J4	Line 2 Active Ant. In (BNC-f)	0.875	1.0625	0.375

TOP SIDE

<u>Hole #</u>	<u>Comp. Desig.</u>	<u>Description</u>	<u>X</u>	<u>Y</u>	<u>D</u>
1	S1	Input Select switch - tab	-1.75	1.5	0.125
2	S1	Input Select switch - shaft	-1.75	1	0.375
3	R1	Line 1 Level pot - shaft	-0.75	2.3125	0.3125
4	R1	Line 1 Level pot - tab	-0.75	2	0.125
5	G2	grounding H/W - int.&ext.lug	-0.75	1.5	0.125
6	R2	Line 2 Level pot - shaft	-0.75	0.6875	0.3125
7	R2	Line 2 Level pot - tab	-0.75	0.375	0.125

8	R3	Phase Null pot - tab	0.25	1.8125	0.125
9	R3	Phase Null pot - shaft	0.25	1.5	0.3125
10	A1	BUF-F amp card mounting H/W	1.25	1.8	0.125

RIGHT SIDE

<u>Hole #</u>	<u>Comp. Desig.</u>	<u>Description</u>	<u>X</u>	<u>Y</u>	<u>D</u>
1	G3	grounding H/W - int.&ext.lug	-0.75	0.5	0.125
2	J5	RF Out (BNC-f)	0	0.5	0.375
3	J6	B+ In (RCA-f)	0.75	0.5	0.25

Vendor Codes for Parts Lists

ALD = Allied Electronics = <http://www.alliedelec.com/>

CS = Circuit Specialists = <http://www.cir.com/>

MCL = Mini-Circuits = <http://www.minicircuits.com/>

MOU = Mouser = <http://www.mouser.com/>

NEW = Newark Electronics = <http://www.newark.com/>

RS = Radio Shack = <http://www.radioshack.com/>

Table PL-DXP-3

DXP-3 DXpedition Phaser upper level parts list (bill of materials)

<u>Item</u>	<u>Quantity</u>	<u>Reference</u>	<u>Vendor: Stock Number</u>	<u>Part Description</u>	<u>Notes</u>
1	1	A1	see Table PL-BUF-F	BUF-F Buffer Amplifier card	-
2	5	C1 - C5	CS: CK05104K	Capacitor, 0.1 uF	-
3	2	C6, C7	MOU: 140-50P2-821K	Capacitor, 820 pF	-
4	3	G1 - G3	MOU: 572-01881	Screw, 4-40 * .375"	-

5	3	G1 - G3	MOU: 572-00484	Hex Nut, 4-40	-
6	6	G1 - G3	MOU: 534-7311	Solder lug, #4, internal tooth	2 at each hole (one inside, one outside)
7	1	-	MOU: 572-00649	Lockwasher, #4, split	mount A1
8	1	-	MOU: 5721-440-1/4	Screw, 4-40 * .25"	mount A1
9	5	J1 - J5	RS: 278-105	BNC jack	-
10	1	J6	RS: 274-346	RCA phono jack	-
11	3	R1 - R3	MOU: 31CN301	pot., 1K, linear	-
12	2	R4, R5	CS: RA4.7	Resistor, 4.7 ohm	-
13	2	R6, R7	CS: RA1K	Resistor, 1K	-
14	2	R8, R9	CS: RA470	Resistor, 470 ohm	-
15	2	RFC1, RFC2	MOU: 434-15-222J	RF choke, 2.2 mH	-
16	1	S1	MOU: 10YX034	Switch, 3-pole, 4-pos. rotary	-
17	2	T1, T2	MCL: T16-6T-X65	RF transformer, 1:16	-
18	1	-	RS: 270-238	chassis box, 5.2" * 2.92" * 2.125"	-
19	4	-	MOU: 45KN013	knob (0.94" dia.)	for R1-R3, S1

Misc. items: hook-up wire, buss wire, solder, labels "AS REQUIRED"

Table PL-BUF-F

BUF-F Buffer Amplifier card parts list (bill of materials)

<u>Item</u>	<u>Quantity</u>	<u>Reference</u>	<u>Vendor: Stock Number</u>	<u>Part Description</u>	<u>Notes</u>
1	2	C1 - C2	CS: CK05103K	Capacitor, 0.01 uF	-
2	1	C3	CS: TAC008	Capacitor, Tantalum, 10 uF, 35 V	-
3	1	C4	CS: CK05104K	Capacitor, 0.1 uF	-
4	1	H_PB1	RS: 276-1396	Perfboard	cut size 1.0" * 1.0"
5	1	H_SC1	MOU: 5721-440-1/4	Screw, 4-40 * .25"	stock num.= 100 pieces
6	1	H_SL1	MOU: 534-7311	Solder lug, #4, internal tooth	-
7	1	H_SO1	CS: CA-8	Socket, 8-pin DIP	for U1
8	1	H_SP1	MOU: 534-1450C	Spacer, 4-40 * .5"	-
9	4	P1 - P4	CS: T42-1/100	Flea-clip Terminal Pin for .042" hole	-
10	1	R1	CS: RA33	Resistor, 33 ohm	-
11	1	R2	CS: RA15	Resistor, 15 ohm	-
12	2	R3 - R4	CS: 560K	Resistor, 560K	-
13	1	R5	CS: RA4.7	Resistor, 4.7 ohm	-
14	1	U1	NEW: 06F5241 (or) ALD: 903-3056	Harris HA3-5002-5 Buffer Amplifier, 8-pin DIP	-

plus buss wire, solder "as required"

DRAWINGS

DXP-3
DXpedition Phasing Unit
Figure 1 : Input Section

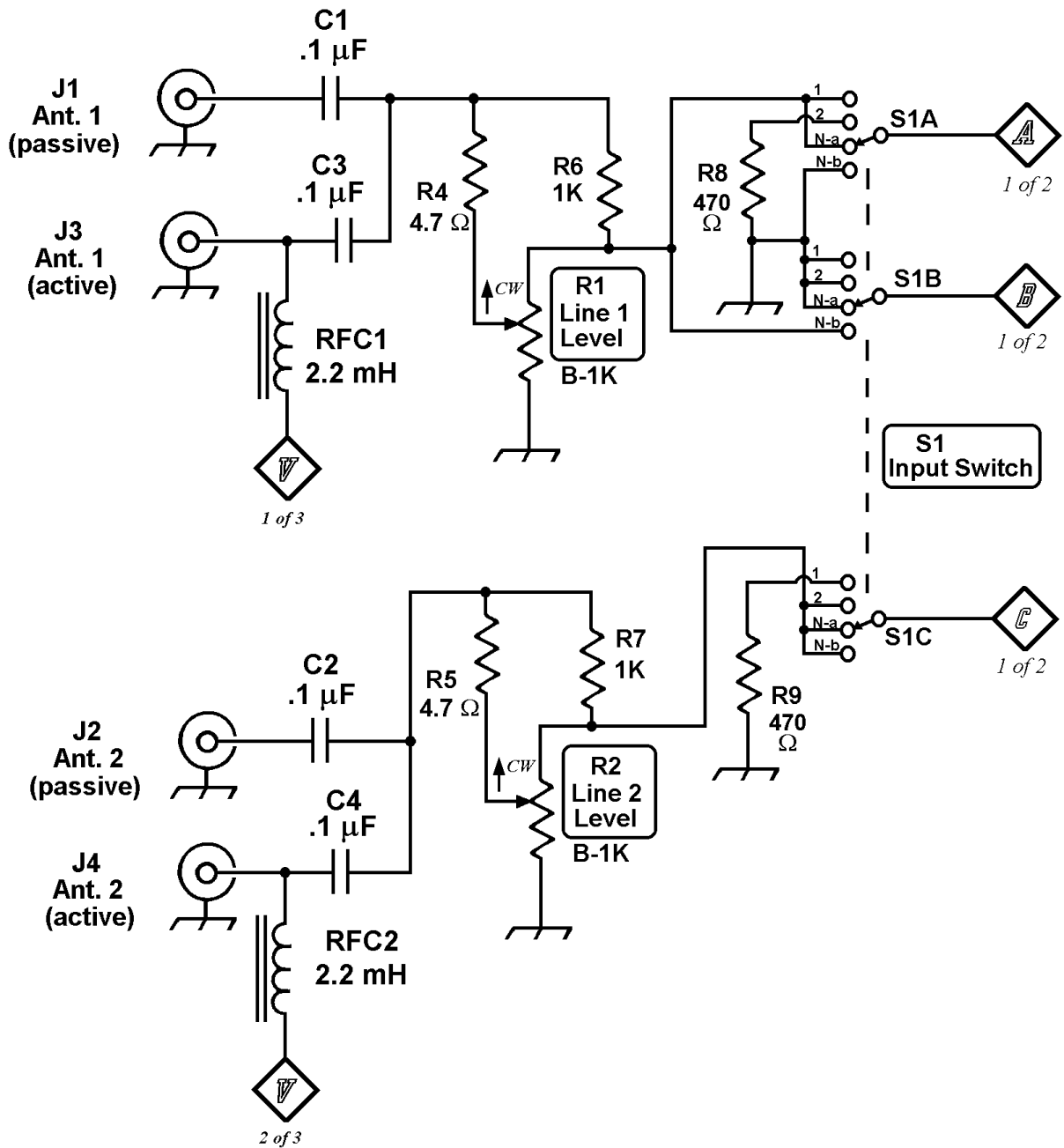

input section schematic above

DXP-3

DXpedition Phasing Unit

Figure 2: Output Section

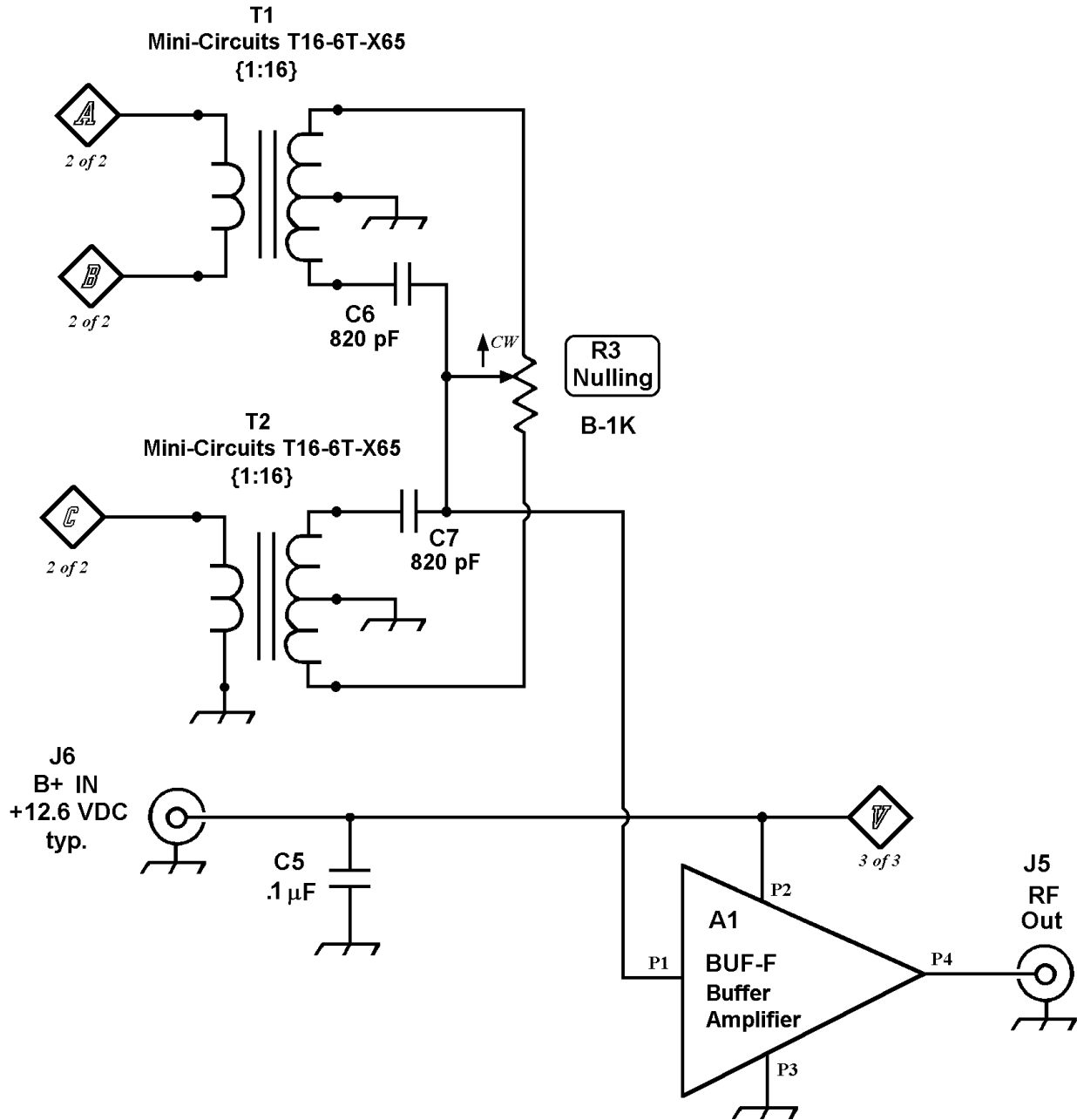

output section schematic above

BUF-F BUFFER AMPLIFIER CARD

Drawing BUF-F_F1: Schematic

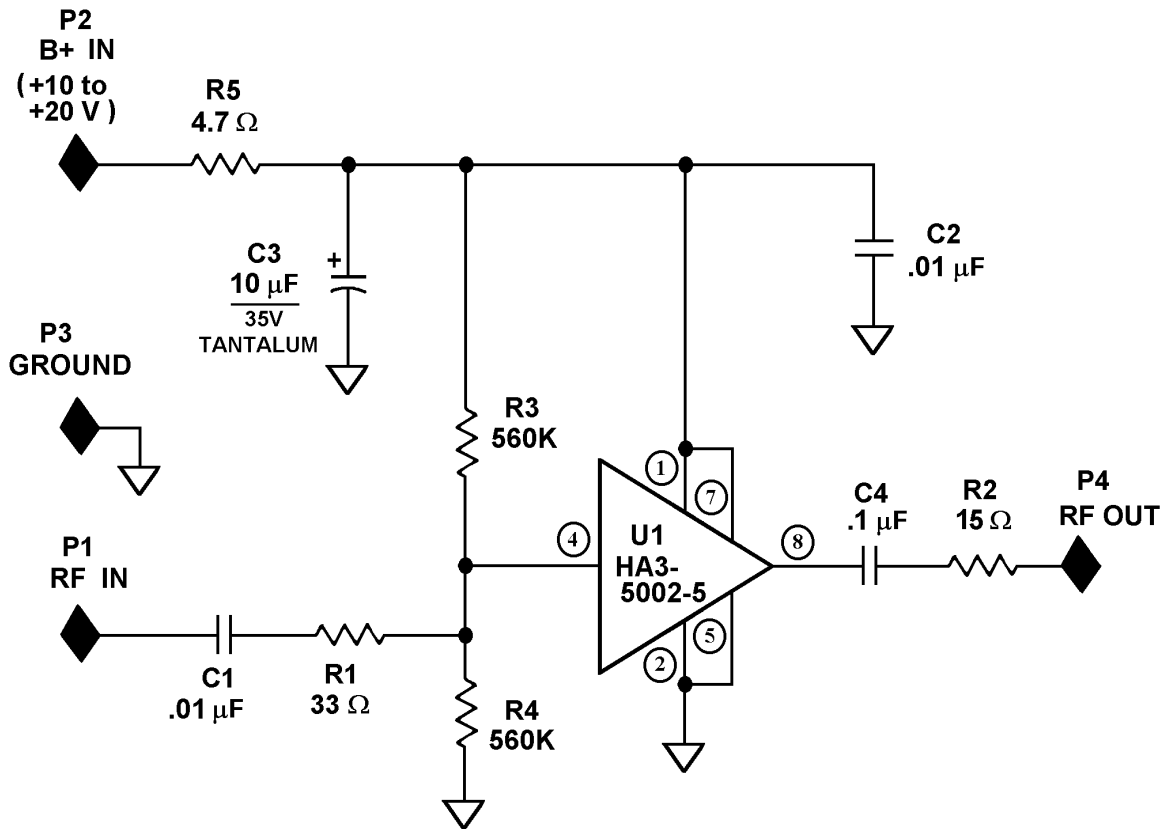

BUF-F Buffer Amplifier schematic above

BUF-F BUFFER AMPLIFIER CARD

Drawing BUF-F_F2: Assembly

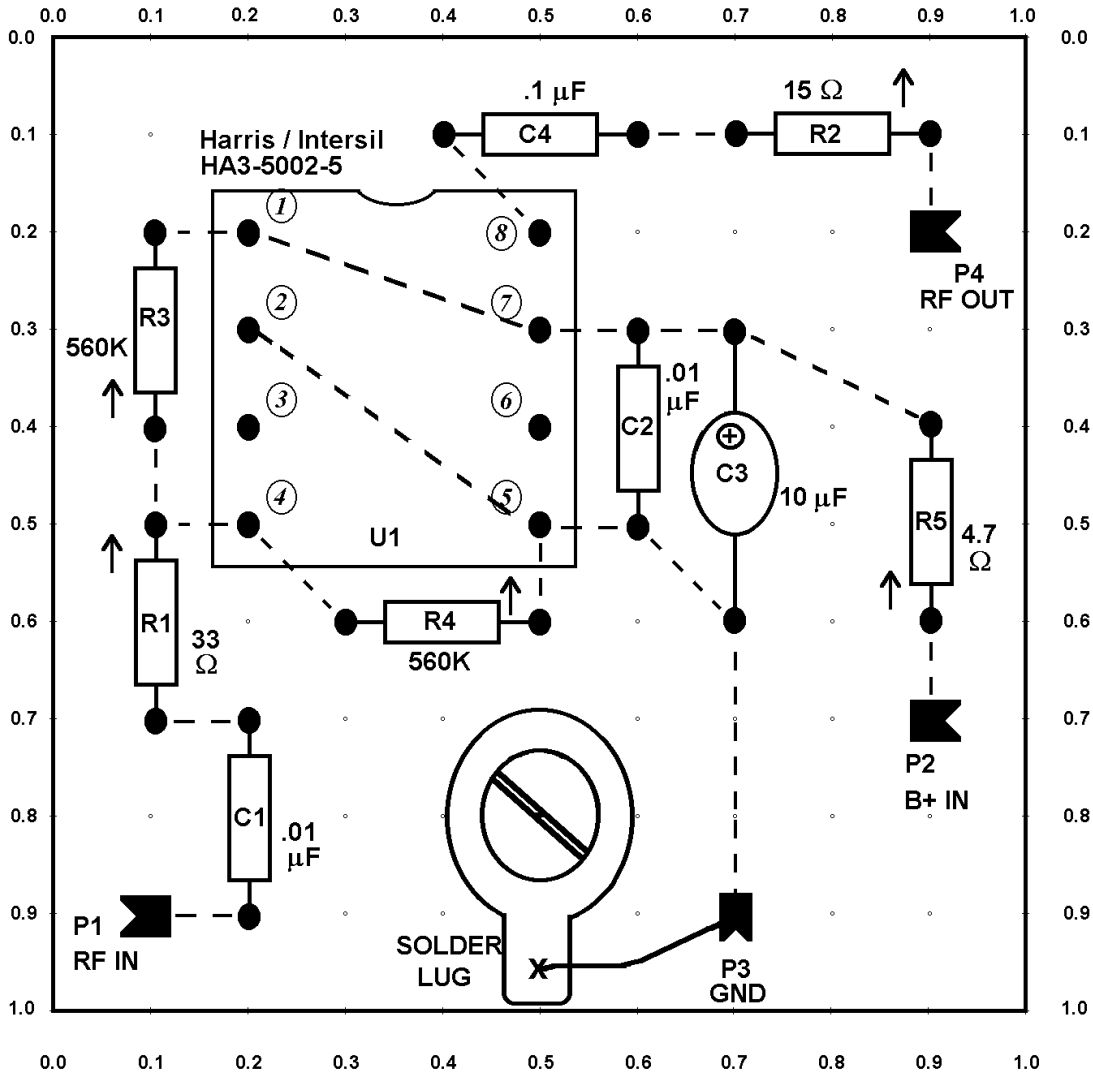

NOTES

- ↑ = Long lead side of vertically-mounted component
- - - = Buss wire on solder side of board
- = Buss wire on component side of board
- ◀ = "Flea clip" terminal pin
OPEN SIDE

BUF-F Buffer Amplifier assembly above

APPENDIX

Photographs of a completed unit

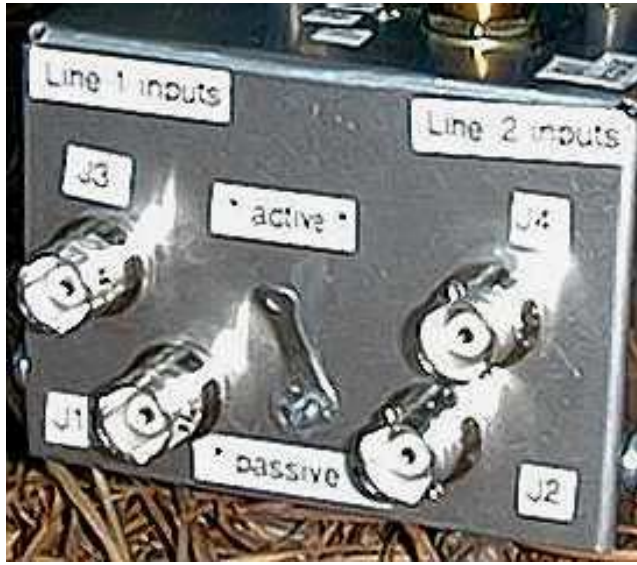

Left Side



Top



Right Side

A tuned circuit may be added to reduce the likelihood of mixing products in urban areas. This will require a larger box size. Schematic is shown below:

