

# Power Supply Design using Series Regulator Packages

by Lloyd Butler VK5BR

(Originally published in Amateur Radio, February 1987)

## A Design Procedure is outlined for Low Voltage Regulated DC supplies using Voltage Regulator I/C Packages

### INTRODUCTION

Because complete voltage regulator packages are readily available in current ratings up to 10 amps, the assembly of a low voltage supply for load currents in this range is a relatively easy task. Notwithstanding this, before proceeding with the task, a number of important circuit details must be worked out so that suitable components can be selected to work in conjunction with the regulator package. Such details include the following:

- The transformer secondary voltage and load current rating.
- The size of the reservoir capacitor.
- The maximum power dissipation in the regulator and rectifier units.
- The size of the heat sinks.
- Surge current into the rectifier unit.

Other considerations include the careful placement of bypass capacitors to prevent instability of the regulator or RF getting back into the regulator from a transmitter load and the need for protection diodes to protect the regulator in the event of a short circuit.

The intention of this article is to discuss the general aspects of the regulated power supply design. However, to assist in the discussion, the development of a sample power supply to deliver 13 volts at a maximum load of 10 amps will be considered. A suitable voltage regulator for this purpose is the LM396, which can regulate for an output voltage range of 1.25 volts to 15 volts at a load current up to 10 amps and dissipate power up to 70 watts. A power supply envisaged is illustrated in Figure 1.

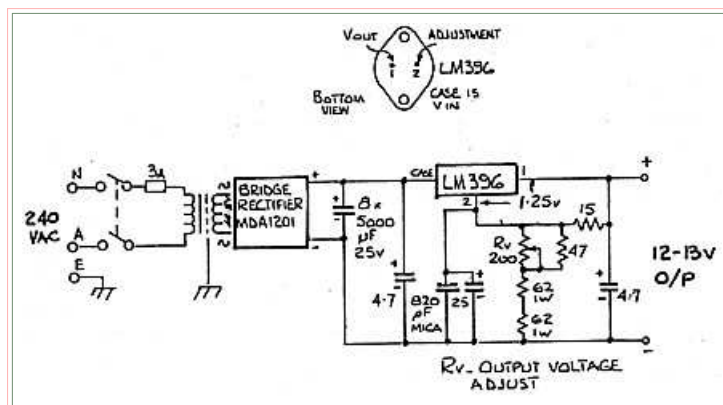
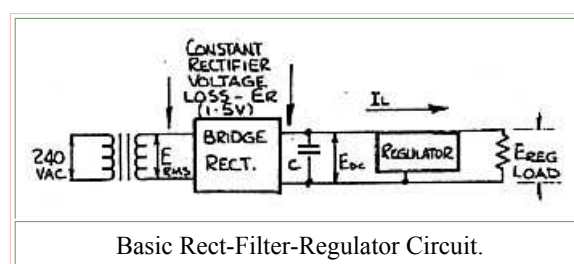

Figure 1 - 12-13 volt, 10 amp Power Supply. Basic Rect-Filter-Regulator Circuit.

### CIRCUIT R-C CONSTANTS

The DC power supply can be resolved into three components as shown in Figure 2, the source resistance ( $R_s$ ) the filter capacitance ( $C$ ), and the load resistance ( $R_L$ ).



Basic Rect-Filter-Regulator Circuit.

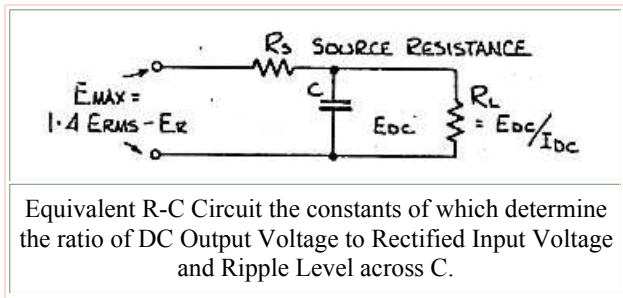
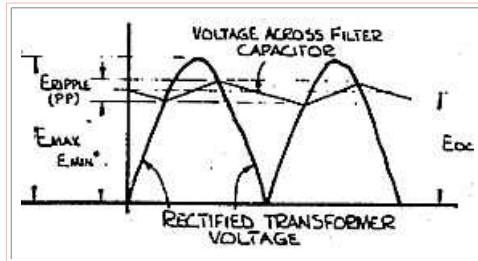

**Figure 2**

The source resistance ( $R_s$ ) includes rectifier resistance and transformer loss resistance. However voltage loss in a silicon rectifier is substantially constant over most of its load range and hence the source resistance is essentially that resistance caused by the transformer core and winding losses. For the silicon bridge rectifier, two diodes conduct in series during each half cycle and voltage loss is about 1.5 volts. To calculate the effective source peak DC voltage ( $E_{max}$ ) we simply subtract 1.5 volts from the transformer secondary peak AC voltage.

Load resistance ( $R_L$ ) is the average DC voltage ( $E_{dc}$ ) developed across capacitance ( $C$ ) divided by the maximum DC load current ( $I_L$ ).

The DC voltage developed across  $C$  is a function of the charge time constant  $R_s C$  and the discharge time constant  $C R_L$  and as illustrated in Figure 3, includes a ripple component caused by the charging and discharging process. The voltage regulator which follows acts as a second stage ripple filter and if it is to work correctly, the voltage trough ( $E_{min}$ ), caused by the ripple, must not be less than the sum of the regulated output voltage and the regulated drop-out voltage.



**Figure 3**

**Charge and Discharge of Filter Capacitor from Source and Into Load respectively.  $E_{min}$  must be greater than the sum of the regulated load voltage and the regulator drop out voltage.**

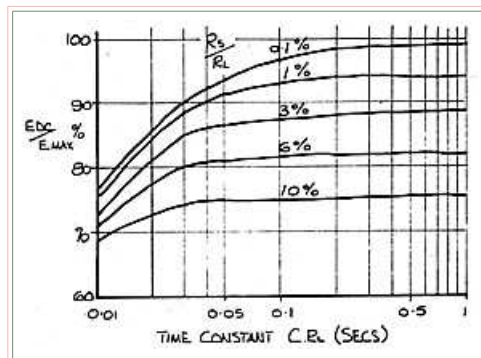

**Figure 4**

**Ratio of Average DC Voltage across C to Peak Rectified Voltage as a Function of Time Constant  $C R_L$  for Full Wave Rectifier.**

Figure 4 shows the ratio  $E_{dc}$  to  $E_{max}$  as a function of time constant  $C R_L$  for various ratios of  $R_s$  to  $R_L$ . These curves have been derived from more comprehensive curves originally developed by Shade, Proc IRE Vol 31, 1943 and republished in a number of other reference sources. From the curves, it can be seen that to obtain high developed voltage,  $R_s$  must be as low as possible and time constant  $C R_L$  must be not less than 0.05 second.

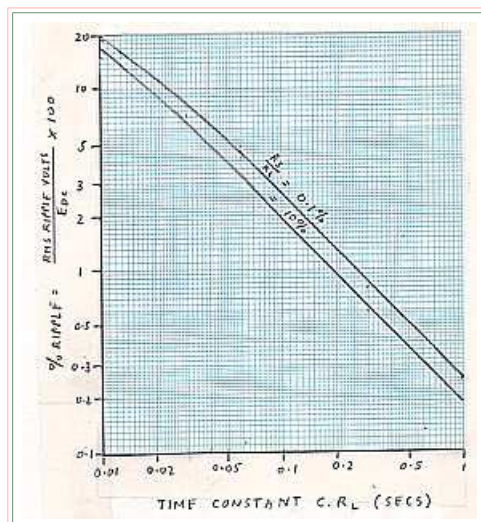

### Figure 5 Percentage Ripple as a Function of Time Constant ( $C_R$ ) for Full Wave Rectifier.

We now examine a second set of curves, Figure 5, which plot ripple percent as a function of time constant  $C_R$  for a range of ratios  $R_S/R_L$ . We see that  $R_S$  affects the ripple a minor amount and that for time constants ( $C_R$ ) of 0.05 to 0.1 second, ripple percent is around 2 to 4 percent, hence trough ( $E_{min}$ ) is very close to  $E_{dc}$ . From the two diagrams, we can also see that there is little to be gained by using time constants above 0.1 second.

A time constant  $C_R$  lower than 0.05 second can be used but more transformer secondary voltage would be required to obtain a value of  $E_{min}$  necessary to prevent regulator cut-off. Another disadvantage is that, with the higher ripple level and a greater ratio of  $E_{dc}$  to  $E_{min}$ , the voltage differential across the regulator must be higher and hence a higher regulator power dissipation. In essence, what is saved in filter capacitance is lost in the need for a larger heat sink.

A time constant  $C_R = 0.07$  second seems to be a good choice for the average case.

#### REGULATOR INPUT VOLTAGE

On the basis of our previous discussions and allowing five percent for mains voltage variation and the ripple trough, we can set the value of  $E_{dc}$  as follows:

$$E_{dc} = 1.05 (E_L + E_{do})$$

where  $E_L$  is the load voltage

and  $E_{do}$  is the regulator drop-out voltage.

Considering our load sample of 13 volts at 10 amps and our LM396 regulator, we can work out  $E_{dc}$  for that case. The drop out voltage of the LM396 is given as a typical 2.1 volts, but could be as high as 2.75 volts. Using the 2.75 volts, we get:

$$E_{dc} = 1.05(13 + 2.75) = 16.5 \text{ volts.}$$

Unless you are worried about the mains voltage failing further, there is little point in allowing more margin as this means more power which must be dissipated in the regulator.

#### CAPACITANCE (C)

From our previous discussion on the time constant of  $C_R$  let us decide to use a time constant of 0.07 second. Our ripple voltage will be about three percent and our average voltage ( $E_{dc}$ ) across C will be within 1.5 percent of  $E_{min}$ . Load resistance is calculated as follows:

$$R_L = E_{dc}/I_L = 16.5/10 = 1.65 \text{ ohms}$$

Capacitance C is then calculated from:

$$C = T/R_L = (0.07 \times 10^6)/1.85 \text{ microfarads}$$

where T = time constant  $C_R$

i.e., C = 42,400 mfd (say 40,000 mfd).

This is a large capacitance which can be built up, if necessary, from paralleled smaller values. Voltage rating must be not less than  $1.4 \times E_{rms}$  (The transformer secondary voltage to be calculated later).

#### RECTIFIER RATING

To proceed further with selecting the transformer secondary voltage based on the curves of Figure 4, we need to know the value of  $R_S$ . However, before looking at this, we must examine the rectifier bridge and how it is also affected by the value of  $R_S$ .

Rectifier ratings which must be considered are as follows:

1. The maximum average current rating ( $I_o$ ) to be not less than the maximum load current ( $I_L$ ).
2. The peak inverse voltage rating ( $V_{rrm}$ ) to be not less than  $2.8 E_{rms}$  (twice the peak secondary voltage) plus a safety margin up to 50 percent higher to allow for line transients.
3. The surge current rating ( $I_{fsm}$ ) in relation to source resistance ( $R_S$ ) - to be discussed further.

The maximum instantaneous surge current, on switch on, is equal to  $(1.4 E_{rms} - 1.5) / R_S$  and this flows to charge C. The peak voltage is reduced by 1.5 because of the voltage loss in the bridge itself.

Suppose we select rectifier bridge type MDA1201 for our sample supply. This has a maximum average current rating of 12 amps and a peak inverse voltage rating of 100 volts, more than sufficient for our 13 volt, 10 amp power supply. The  $I_{FSM}$  rating of the bridge is 400 amps.

Referring back to Figure 4, we can expect the average DC voltage ( $E_{dc}$ ) to be as low as 85 percent of the peak value, hence the rectifier surge current sourced from the transformer primary, could be as high as  $E_{dc}/0.85 R_S$ . Transposing the formula we could say, that to safeguard the rectifier bridge,  $R_S$  must be not less than  $E_{dc}/(0.85 I_{FSM})$ . Applying this to our power supply, minimum source resistance ( $R_{Sm}$ ) is calculated as follows:

$$R_{Sm} = E_{dc}/(0.85 I_{FSM}) = 16.5/(0.85 \times 400) = 0.05 \text{ ohm}$$

Now  $R_L$  was calculated previously as 1.65 ohms, hence the lowest ratio of  $R_S/R_L$  possible is  $0.05/1.65 = 3$  percent which we will refer to later.

Another requirement of the  $I_{FSM}$  rating is that the surge should not be sustained and the time constant  $R_S C$  should not be greater than one half AC cycle (often quoted as 8.3 msec for a 60Hz supply). In the case of our supply,  $R_S C = 0.05 \times 40,000/1000 \text{ msec} = 2 \text{ msec}$  and no problem.

## THE TRANSFORMER

The problem with the transformer is that until it is obtained, its source resistance ( $R_S$ ) is an unknown factor, which in turn, affects the choice of its secondary voltage. At this stage we might assume that it has the minimum source resistance required to limit the rectifier surge current, as previously calculated, and therefore has the ratio  $R_S/R_L = 3$  percent. Referring back to Figure 4, for a time constant  $CR_L = 0.07$  second and  $R_S/R_L = 3$  percent, ratio  $E_{dc}/E_{max} = 87$  percent. We can now calculate our first estimate of secondary RMS voltage as follows:

$$E_{rms} = 0.7 (E_{dc}/0.87 + 1.5) = 0.7 (16.5/0.87 + 1.5) = 14.3 \text{ volts.}$$

Secondary current rating is equal to  $1.4 I_L$ , and for our sample supply is 14 amps. Power rating of the transformer is  $E_{rms} \times I_{rms}$  which is  $14.3 \times 14 = 200$  watts.

At this stage, a few words might be said about the cost of the transformer. A 200 watt transformer can be an expensive item and if the building of such a large supply is contemplated, a search for a transformer from some old equipment is well worthwhile. Transformers from old black and white television sets can be put to good use. These transformers are usually rated about 200 watts and would be good for higher powers in amateur radio intermittent load applications. Heater windings on these transformers have heavy gauge wire and it is possible to achieve enough voltage for a 13 volt DC supply by series connection of some of these windings. The writer was able to obtain sufficient voltage on a similar supply by series connection of two 6.3 volt windings and tapping down the mains primary connection.

If the secondary has to be rewound, carefully remove the old outer windings and count the turns to obtain the number of turns per volt used. As a guide to winding wire selection, 1000 circular mils-per-amp is a conservative rating, but the ARRL Handbook suggests 700 circular mils-per-amp as common for amateur intermittent service. On this basis, suggested wire gauges are as follows:

1amp 22 SWG  
2amp 20 SWG  
3amp 18SWG  
6amp 16SWG  
9amp 14SWG  
12amp 13SWG  
16amp 12SWG

If you are using the power supply to operate a single sideband transmitter, you might be able to get away with an even smaller gauge than these. Whilst the voltage regulator must be rated for maximum current swing, the transformer heating is dependent on average current through its windings. You should check your transmitter average load current under speech conditions as you might find you can down-grade the power rating of the transformer considerably.

Having obtained a transformer, or rewound one, or whatever, we are still in the position where we are guessing about the value of source resistance ( $R_S$ ). What we can do is to measure its value as shown in Figure 6. Here the difference is measured between the secondary voltage unloaded and the secondary voltage loaded with a large current. Some form of dummy load, such as a network of high wattage resistors, is needed for this test.

$$\text{Source Resistance } (R_S) = [(V_{noload} - V_{load}) \times R_{load}]/V_{load}$$

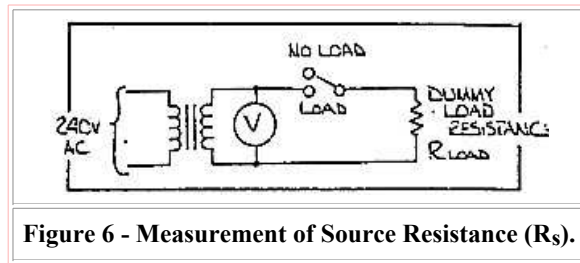

**Figure 6 - Measurement of Source Resistance ( $R_s$ ).**

If  $R_S$  turns out to be less than that required to protect the rectifier, resistance should be added in series with the secondary winding or the rectifier bridge output to build up  $R_S$  to the protection value. If this is the case, the initial calculation for the transformer secondary RMS voltage is correct. If  $R_S$  is more than this value, ratio  $R_S/R_L$  is recalculated, a new ratio of  $E_{dc}/E_{max}$  percent is read from Figure 4 and a new value of RMS secondary voltage is calculated as follows:

$$E_{rms} = 0.7 (E_{dc}/R_d + 1.5)$$

where  $R_d = E_{dc}/(100 E_{max})$

This of course means a probable addition of more turns to the secondary winding.

A less harassing procedure might be to make the transformer secondary with a little higher voltage to start with and if  $E_{dc}$  turns out to be higher than required, add resistance in series with the secondary, or the rectifier, so that  $R_S$  is increased to lower  $E_{dc}$  to the desired value. Again, it is emphasised that if  $E_{dc}$  is higher than necessary, there is unnecessary heat dissipation in the voltage regulator.

## HEAT SINKING

To control the junction temperature of the voltage regulator within its rated specification, an effective heat sink is required. Where large currents are involved, the rectifier bridge also requires heat sinking.

To choose the heat sink, the following data is needed:

- Maximum power dissipation in the device  $P_m$ .
- Maximum rated temperature of the device junction ( $T_j$ ).
- Thermal resistance of the device junction to device case ( $R_{jc}$ ).
- Thermal resistance of the device case to heat sink ( $R_{cs}$ ) i.e. the device insulating washer.
- Maximum ambient temperature in which the device and heat sink must operate ( $T_a$ )

Thermal resistance between two points is the rise in the temperature per watt dissipated ( $^{\circ}C/W$ ).

Thermal resistance of the heat sink to air is  $R_{sa}$  and the total thermal resistance, junction to air ( $R_{ja}$ ) is the sum of the other resistances in the heat dissipating chain.

$$\text{ie } R_{ja} = R_{jc} + R_{cs} + R_{sa}$$

To find the required thermal resistance of the heat sink and subsequently to choose its size, its thermal resistance is calculated as follows:

$$R_{sa} = [(T_j - T_a)/P_m] - R_{cs} - R_{jc}$$

$T_j$  and  $R_c$  are obtained from the device data. The value of  $T_a$  is dependent on the environment of operation. In the comfort of the radio shack, 40 degrees Celsius could be adequate but this might have to be raised if the heat sink is located where there is restricted air flow or localised air heated by other equipment. In the boot (or trunk) of a motor vehicle on a hot day, ambient temperature could be as high as 65 to 70 degrees Celsius.

The importance of selecting an insulating washer for the device is emphasised particularly where high dissipation powers are involved (say over 10 watts). A colleague of the writer, who had some heat sink problems, carried out some tests to measure the thermal resistance of various T03 type case insulating washers, which were at hand. The results were as follows:

No washer with silicone compound	0.062 $^{\circ}C/W$
Beryllium Oxide	0.096 $^{\circ}C/W$
Mica	0.16 $^{\circ}C/W$
Silicone Rubber Fibreglass Composite (a) without silicone compound	0.58 $^{\circ}C/W$
Silicone Rubber Fibreglass Composite (b) with silicone compound	0.27 $^{\circ}C/W$

For low dissipation power (say 10 watts), the type of washer is of little consequence, however if large powers were involved (say 70 watts), the silicone rubber composite, without silicone compound, would develop a temperature differential of  $70 \times 0.58 = 40.6$  degrees compared to only  $70 \times 0.096 = 6.7$  degrees for the Beryllium Oxide washer.

No insulating washer gives the lowest temperature differential, but this means the heat sink must be electrically above ground potential with possible hazardous consequences in the event of a short circuit to ground. Also, in this case, the heat sink is isolated from the chassis which means that the chassis itself cannot assist in dissipating the heat.

The best washers are Beryllium Oxide although there is often some hesitance to use these because if the material is machined, the fine dust from machining is toxic. In its solid state the material is apparently quite safe, but the moral is not to machine it.

Referring back to our sample power supply of 13 volts at 10 amps, the power dissipation in the regulator is calculated as follows:

$$P_m = (E_{dc} - E_L) \times I_L$$

where  $(E_{dc} - E_L)$  represents the voltage loss across the voltage regulator and  $I_L$  is the load current.

i.e.  $P_m = (16.5 - 13) \times 10 = 35 \text{ watts}$

Allowing a margin of 10 percent, we will assume a maximum dissipation of  $35 \times 1.1 = 39 \text{ watts}$ . The maximum junction temperature of the LM396 is given as 175 degrees Celsius and the maximum thermal resistance junction to case ( $R_{sjc}$ ) is given as  $1.2 \text{ }^\circ\text{C/W}$ .

Let us assume that a mica washer is used, as this might be easier to obtain than the Beryllium washer. Depending on the thickness, this could have a thermal resistance as high as  $0.50 \text{ }^\circ\text{C/W}$ . The maximum ambient temperature ( $T_a$ ) will be assumed to be 40 degrees Celsius.

From the preceding data, the maximum thermal resistance of the heat sink is then calculated as follows:

$$R_{sa} = [(175 - 40)/39] - 0.5 - 1.2 = 1.76 \text{ }^\circ\text{C/W}$$

A diagram of the heat gradient which results is shown in Figure 7, Note that the maximum temperature rise in the heat sink is:

$$39 \text{ W} \times 1.76 \text{ }^\circ\text{C/W} = 69.$$

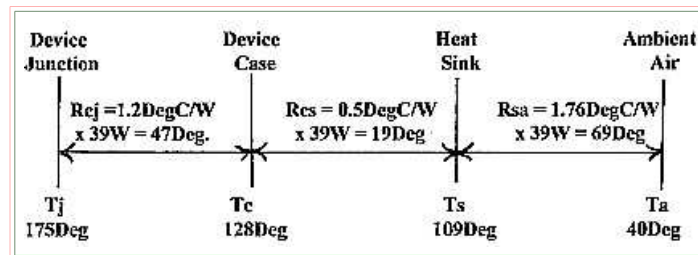

Figure 7 - Temperature Gradient Worst Conditions.

The next step is to examine some heat sink curves for commercial heat sink material which could be available. Typical curves for the Mullard 35D material is shown in Figure 8.

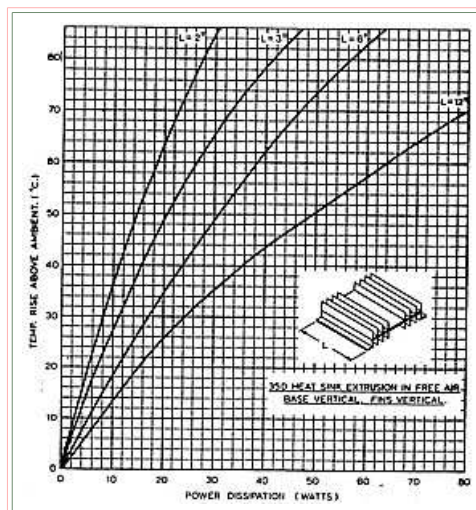

Figure 8 - Power Dissipation Tabulated against Temperature Rise for Various Lengths of 35D Heat sink Extrusion.



Examination of these curves indicates that the minimum length of this material to limit the temperature rise to 69, for a dissipation of 39 watts, is about five inches. Of course, we do not have to use this particular material and some other material might be available on the secondhand market from redundant equipment.

Whilst special heat sinks are necessary for large dissipation powers, lower powers (say 10 watts) can often be satisfactorily dissipated by mounting the device directly on the case of the equipment. Figure 9 gives a guide to the surface area of metal given a power dissipation and temperature differential above ambient value. As an example from the curves, 10 watts will raise the temperature of 50 square-inches to 45 degrees Celsius above ambient temperature. That is, it has a thermal resistance of 4.5 °C/W.

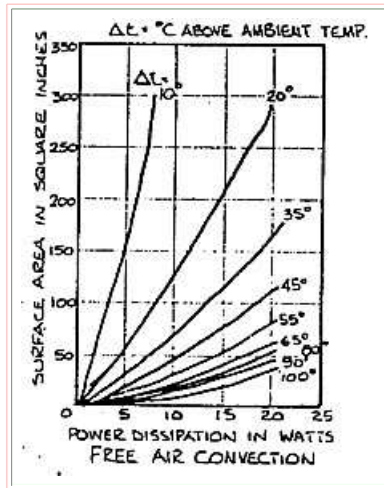

Figure 9 - Temperature Rise versus Power Dissipation for a Plane Heat sink.

The performance of heat transfer can be checked by monitoring the device case and the heat sink with a temperature probe. This sort of test equipment is not generally found around the radio amateur's shack, but is very useful if one can be borrowed. A rough idea of the performance can be judged by hand. If the heat sink feels too hot, then it probably is! If the device case is much hotter than the heat sink, a better insulating washer could be indicated.

The heat sink should be mounted in a place where air-flow is free and the fins of the heat sink should be positioned in the vertical plane to aid airflow. A blackened heat sink radiates heat more effectively than an unblackened one. Heat dissipation from the heat sink can be made more effective by forced air cooling, that is, its effective thermal resistance is lowered.

### THE RECTIFIER SINK

Whilst on the subject of heat sinks, we must not forget the rectifier bridge, which in the sample supply, must dissipate 1.5 volts at 10 amps = 15watts.

The MDA1201 is rated at a maximum junction temperature of 175 degrees Celsius and a maximum case temperature of 100 degrees Celsius at its maximum current rating (I<sub>o</sub>) of 12 amps. From this, we calculate junction to case thermal resistance as follows:

$$R_{jc} = (T_j - T_c) / (1.5 \times I_o) = (175 - 100) / (1.5 \times 12) = 4.17 \text{ } ^\circ\text{C/W}$$

The rectifier bridge case does not have to be insulated so we give the case to sink thermal resistance (R<sub>cs</sub>) a value of 0.1.

Using a previous formula for the thermal resistance of heat sink to air:

$$R_{sa} = [(T_j - T_a) / P_m] - R_{cs} - R_{jc} = 175 - 40 = 4.73 \text{ } ^\circ\text{C/W}$$

This means a temperature rise of 15 x 4.73 = 71° in the heat sink, as a maximum. Referring to Figure 9, we require a plane heat sink of not less than 30 square inches. Direct mounting of the rectifier bridge on the power supply chassis is usually sufficient to satisfy this requirement.

A few final remarks should be said about mounting semiconductor devices on the heat sink. Care should be taken to ensure that the mounting surface is flat and smooth, so that it makes good thermal contact. Make sure there are no drilling burrs to prevent complete surface contact and which could puncture the insulating washer and hence bridge the insulation. Use silicone grease or other heat sink compound on the joint to improve heat transfer.

### REFERENCE VOLTAGE

Voltage regulator packages are generally three terminal devices with an input, an output and a voltage reference terminal. In fixed voltage regulators, the reference pin is connected to the common power rail. In adjustable regulators, such as the

LM396, a resistive voltage divider is required to divide the load voltage down to reference level ( $V_{ref}$ ) as specified for the regulator. In the case of the LM396, the reference voltage is 1.25 volts and Figure 1 illustrates a divider network which allows an output voltage adjustment between 12 and 13 volts.

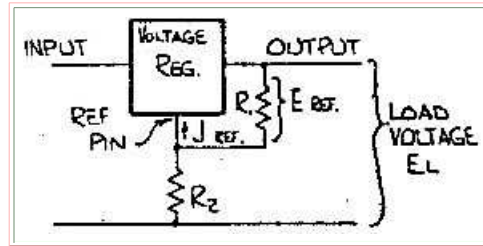

Figure 10 - Voltage Divider to set Output Voltage.

In selecting resistance values for the divider network, the bleed current through the network is made large compared to the input current of the reference pin (at least 10 times). Referring to Figure 10, a little exercise in ohms law gives us the following:

$$R_1 < E_{ref}/(10 \times I_{ref})$$

$$R_2 = [(E_L - E_{ref}) \times R_L]/E_{ref}$$

The power in each resistor is also calculated so that the correct rated resistor can be selected:

$$\text{Power in } R_1 = (E_{ref})^2/R_1$$

$$\text{Power in } R_2 = [(E_L - E_{ref})^2]/R_2$$

### VARIABLE VOLTAGE SUPPLIES

Resistors R1 and R2 can be replaced with a variable resistance network including a control to vary the output voltage. Suppose in our sample supply we arranged for a control to give a variable supply from 11 to 15 volts. Input voltage  $E_{dc}$  is calculated on the basis of the Maximum output volts (15V), however, heat sink requirements must be based on the lowest voltage (11V), when dissipation across the regulator is greatest.

Assuming the regulator is to supply a maximum of 10 amps over the whole output voltage range, we calculate the following:

$$E_{dc} = E_{Lmax} + 1.1 E_{do} = 15 + 1.1 \times 2.75 = 18.03 \text{ volts.}$$

Maximum power dissipation is calculated as follows:

$$P_m = (E_{dc} - E_{Lmin}) I_L = (18.03 - 11) \times 10 = 70.3 \text{ watts.}$$

Now, this happens to be as far as we can go for the lowest voltage because the LM396 has a power limit of 70 watts. If we tried to go lower than 11 volts with the value of EDC set to allow a maximum output of 15 volts, the dissipation in the LM396 would exceed its 70 watts rating.

Clearly, the maximum power dissipation is much greater in a variable voltage power supply than one set for a fixed voltage and as can be seen from the example, care must be taken in design to ensure that the regulator maximum ratings are not exceeded.

For the example, a low thermal resistance insulating washer, such as Beryllium Oxide is essential and, assuming a value of  $R_{cs} = 0.1 \text{ }^\circ\text{C/W}$ , we get the following:

$$R_{sa} = [R_j - T_a]/P_m - R_{cs} - R_{jc} = [(175 - 40)/70] - 0.1 - 1.2 = 0.63 \text{ }^\circ\text{C/W (ie } 44^\circ \text{ rise for } 70\text{W)}$$

For this application, quite a large heat sink is required. Referring to Figure 11, about nine inches of Mullard 50D heat sink would be required.

One way this high dissipation can be avoided, over a wide output voltage range, is to divide into several ranges with switching to change the transformer secondary taps with range change.

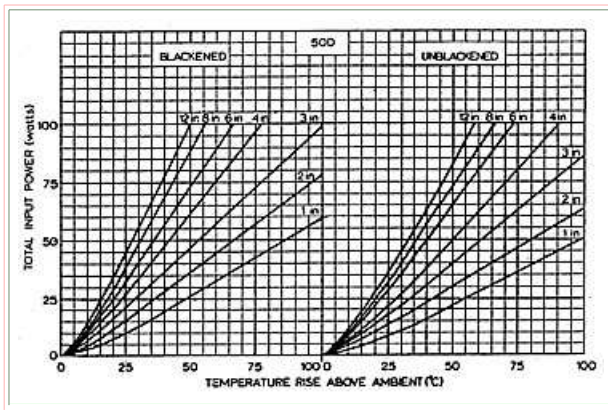

**Figure 11 - 50D Heat sink  
Total Input Power v/s Rise Above Ambient Temperature  
for various lengths of extrusion, with natural convection cooling.**

## BYPASS CAPACITORS

Small bypass capacitors, from the reference pin to common and the output pin to common, are generally required to prevent instability in the regulator. Capacitors which have low impedance at high frequencies, such as tantalums, are necessary and these should be connected with short leads right at the pins of the regulator. If the regulator is used for powering a radio transmitter, the bypass capacitors also prevent RF signals from getting into the control pin of the regulator and being rectified. The writer had one experience with a UA78HGA regulator which supplied 12 volts to a two metre transceiver. On resistive dummy load, the regulator worked perfectly but dropped its voltage when powering the transmitter. The problem was fixed by bypass capacitors, but only after a good quality mica capacitor was selected for the reference pin.

## PROTECTION DIODES

When capacitors are used in conjunction with IC regulators, it is sometimes necessary to add protection diodes to prevent the capacitors from discharging through the low current points in the regulator.

When a capacitor is connected across the output of the regulator and the input is short circuited, the output capacitance will discharge into the output of the regulator and, depending on circuit constants, can possibly damage the regulator.

Another possibility is when a capacitor is connected at the reference or adjustment pin. In this case, a short circuit at either input or output pin can cause a discharge to a low current junction in the regulator. A diode connected between the reference pin and output can protect against this.

Whether these diodes are necessary depends on the type of regulator and its operating conditions and the designer must be guided by the manufacturers specifications. Regulator type LM117 requires this protection if used for output voltages above 25 volts. Figure 12 shows the protection diodes fitted to this regulator. As a general rule, if in doubt put them in anyway. - They cannot do any harm.

Protection diodes should be power types (say 1A) with sufficient surge rating to withstand the discharge surge.

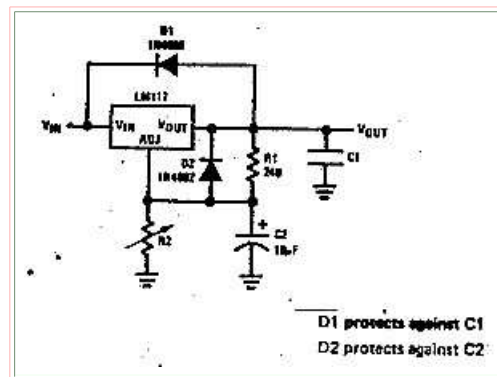

**Figure 12 - LM117 Regulator with Protection Diodes.**

## THE SAMPLE SUPPLY

The sample supply, as shown in Figure 1, was actually built to power such loads as the 1675 transceiver (12.6V at 7A). Being adjustable down to 12 volts, maximum dissipation at the full load capacity of 10 amps has to be calculated at 12 volts. This is as follows:

$$P_m = (E_{dc} - E_{Lmin}) \times I_L = (16.5 - 12) \times 10 = 45W$$

A Beryllium washer with a thermal resistance of 0.1 °C/W was used to insulate the regulator from the heat sink and heat sink thermal resistance ( $R_{sa}$ ) has been calculated as follows:

$$R_{sa} = [(T_j - T_a)/P_m - R_{cs} - R_{jc}] = [(175 - 40)/45] - 0.1 - 1.2 = 1.7 \text{ °C/W}$$

Using the Beryllium washer, the thermal resistance ( $R_{sa}$ ) is very similar to that calculated previously for 13 volts using a higher resistance washer. As such, the heat sink examined before is suitable for this application.

## SUMMARY OF DESIGN PROCEDURE

The following summarises the designs procedure as discussed in the previous paragraphs:

1. Select a suitable voltage regulator for the required output voltage ( $E_L$ ) and maximum load current ( $I_L$ )

2. Calculate input voltage ( $E_{dc}$ )

$$E_{dc} = 1.05 (E_L + E_{do})$$

where  $E_{do}$  is the regulated drop out voltage.

3. Calculate load resistance ( $R_L$ )

$$R_L = E_{dc}/I_L$$

4. Calculate filter capacitance (C)

$$C = T/R_L = (0.07 \times 10^6)/R_L \text{ microfarads}$$

where T = time constant set at 0.07 second.

5. Calculate transformer secondary voltage (first estimate)

$$E_{rms} = 0.7[(E_{dc}/0.85 + 1.5)]$$

6. Select Rectifier Bridge:

Peak Inverse Voltage at least 2.8  $E_{rms}$  plus a 50 percent safety margin.

Peak Current not less than  $I_L$ .

7 Calculate minimum source resistance ( $R_{sm}$ )

$$R_{sm} = E_{dc}/(0.85 \times I_{fsm})$$

where  $I_{fsm}$  is the surge current rating of the rectifier.

8. Check the source resistance ( $R_s$ ) of the transformer

$$R_s = [(V_{noload} - V_{load}) \times R_{load}/V_{load}]$$

If  $R_s$  is less than  $R_{sm}$ , add series resistance to make it equal to  $R_{sm}$ .

9. Calculate ratio  $R_s/R_L$  and find ratio  $E_{dc}/E_{max}$  % from Figure 4 for time constant of 0.07 second.

Putting  $R_d = E_{dc}/E_{max}$  %, Recalculate the RMS secondary voltage

$$E_{rms} = 0.7(E_{dc} + 1.5)/100R_d$$

10. Calculate maximum secondary current ( $I_{rms}$ )

$$I_{rms} = 1.4 I_L$$

11. Calculate maximum power dissipation of the regulating device plus 10 percent margin

$$P_m = 1.1 (E_{dc} - E_L) I_L$$

(Note: For a variable voltage supply  $E_L = E_{Lmin}$ )

12. Calculate maximum thermal resistance of device heat sink ( $T_{ja}$ )

$$T_{ja} = (T_j - T_a)/P_m - R_{cs} - R_{jc}$$

where  $T_j$  = maximum junction temperature.

$T_a$  = Maximum Ambient Temperature.

$R_{cs}$  = Thermal Resistance Case to Sink.

$R_c$  = Thermal Resistance Junction to Case.

Select heat sink from published curves.

13. Repeat calculation (12) for the rectifier. In this case  $P_m = 1.5 I_L$

Ensure adequate heat sink on chassis or external to chassis.

14. If the regulator is an adjustable output voltage type, calculate voltage divider reference resistors:

$$R_1 < E_{\text{ref}} / (10 \times I_{\text{ref}})$$

$$R_2 = (E_L - E_{\text{ref}}) \times R_1 / E_{\text{ref}}$$

where  $E_{\text{ref}}$  = Regulator Reference Pin Voltage

and  $I_{\text{ref}}$  = Reference Pin Load Current

15. Include RF bypass capacitors and protection diodes as may be required.

[Back to HomePage](#)