

The Digital Frequency Meter Kit

The Kits are being assembled and hopefully I will be able to bring some along to the meeting on Friday 8th August.

The Kit will consist of the following :-

Printed Circuit Board

LCD Display module

2 x 14 pin IC sockets

1 x 18 pin IC socket

78L05 regulator

2x 1N4148 silicon diodes (substitute for IN914)

10uF 35 volt electrolytic capacitor

6 x 0.1 uF capacitors (marking on blue cap 104)

33pF disc ceramic capacitor (marking on cap 33K)

100 pF disc ceramic capacitor (marking on cap 101K)

trimmer capacitor 6.2pf to 30pf

2.2K resistor (marking on resistor red red black brown brown red)

1 meg resistor (marking on resistor brown black black yellow brown)

2 x 3.9K resistors (marking on resistor orange white black black red)

470 ohm resistor (marking on resistor yellow orange black black brown red)

1K resistor (marking on the resistor brown brown red brown)

4MHz Xtal

74HC393 IC (marking MC74HC393N)

74LS00 IC

PIC 16F84

MPF102 Field Effect Transistor

PCB Pin Header sets (some kits will have an 18 pin set which will have to be cut into the following units)

2 x 2 pins

2 x 4 pins

2 x 3 pins

2 x 2 pin straps

The printed circuit board is a single sided board with an overlay on one side showing where the components are to be mounted. The other side of the board is the copper printed circuit.

It is very important to follow the instructions in assembling the kit otherwise you may have extreme difficulties in finishing the kit if assembled out of order.

The first stage is to identify all the components of the kit. Once you are satisfied that the kit is complete, it is time to focus on to the printed circuit board. If you check out the component layout you will find 22K in the upper left hand corner. This resistor has been changed to 1Kohm. The positions of the trimmer capacitor and some other capacitors are not shown on the board. The two diodes type 1N914 are shown with their cathodes in the same direction. One diode is reversed and the type provided is 1N4148.

Assembly details about all of the above components will be described in detail as assembly of the kit progresses. You will need a very fine point soldering iron with a suitable temperature as the solder points are very small and close. If too much heat is used the printed circuit track may be damaged and the track lifted off the board.

The PIC IC is static sensitive so the usual precautions to prevent static discharge is necessary.

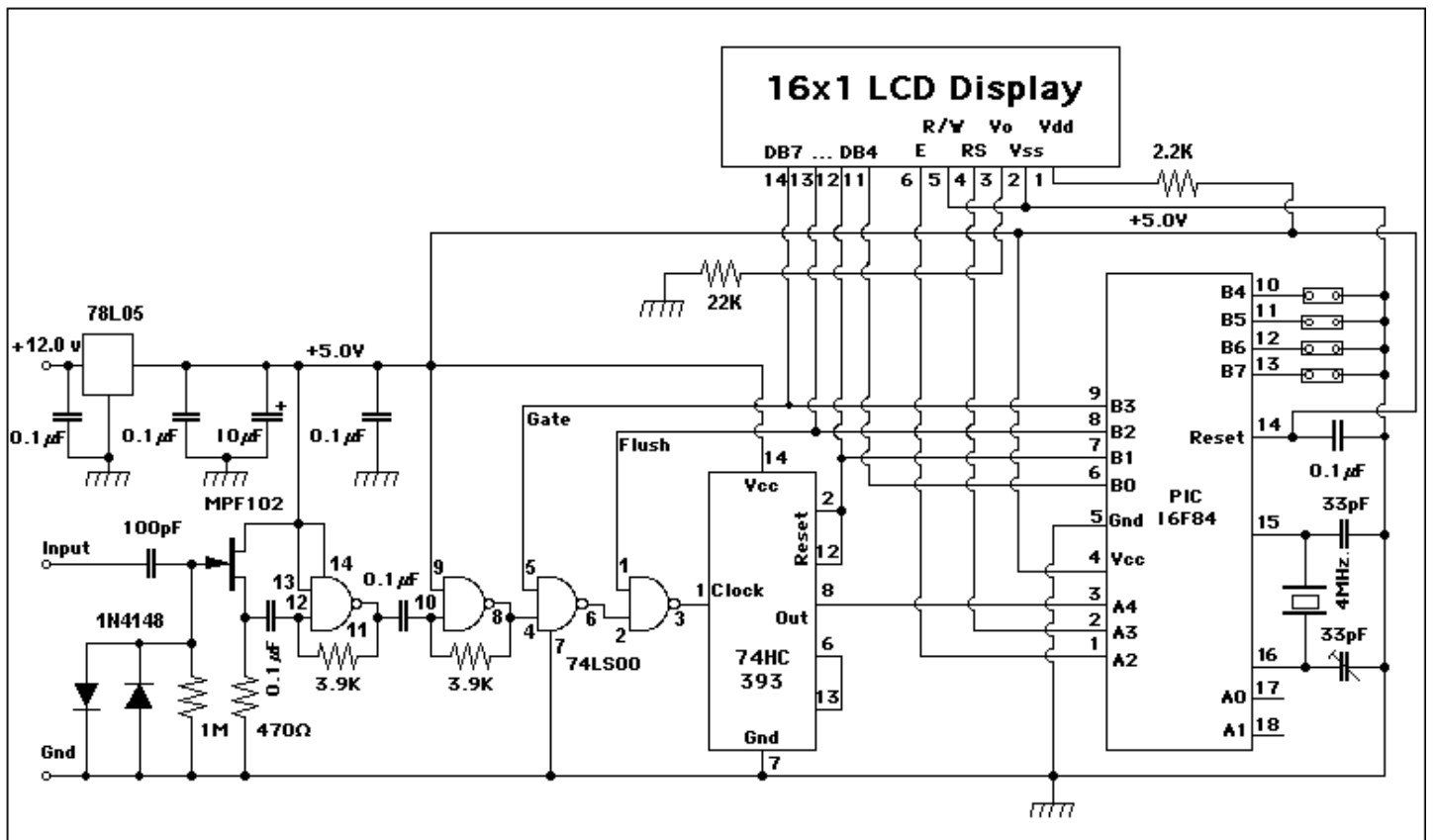

The above circuit shows the complete interconnections of all components. The circuit shows a 22K ohm resistor off pin 3 of the LCD display module. This resistor determines the contrast setting for the display. I have found that the resistor needs to be much smaller than shown to produce reasonable contrast so I have selected a 1K ohm resistor instead of the 22K ohm shown in the circuit.

Construction stages

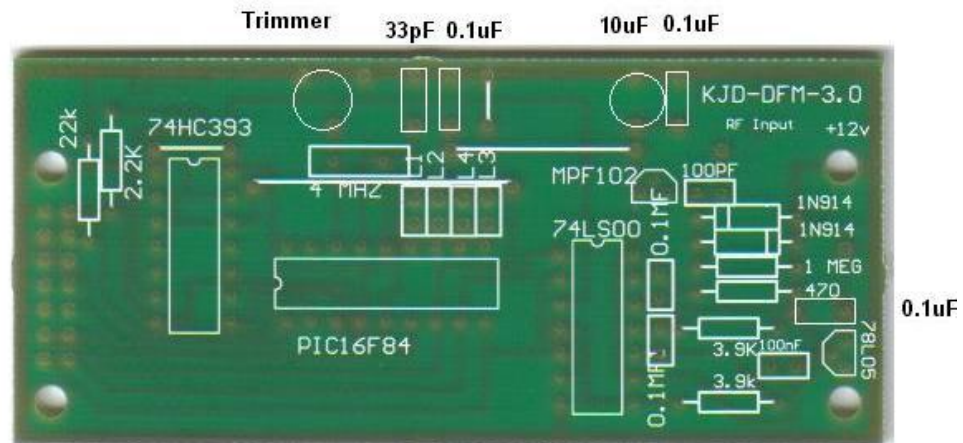

Stage 1.

There are four straps required on the top of the board where the components are shown. They are drawn as three horizontal lines and one vertical line. The vertical line is half way along the top of the board and is 5mm and requires a strap of tinned copper wire to pass through the holes and be soldered to the pad on the bottom of the board.

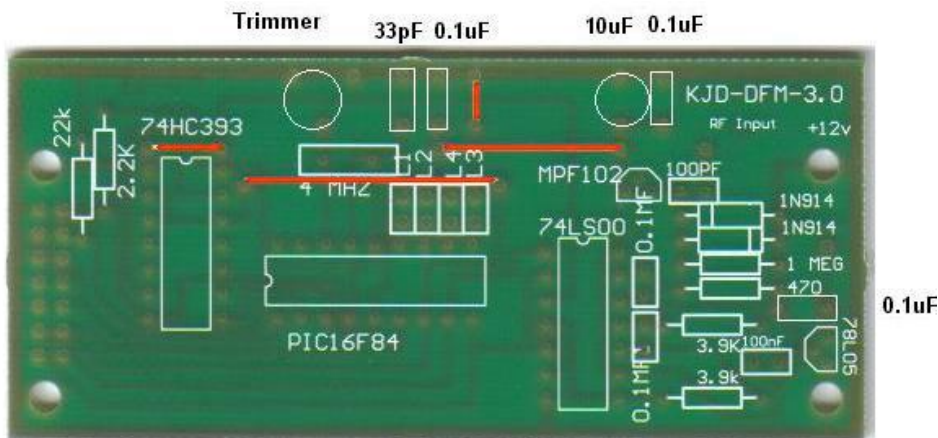

The horizontal straps are just under the vertical strap with the short strap just under the 74HC393 marking. These straps will use similar wire. The lengths of the straps between the holes are:- 7mm, 19mm (just under the vertical strap) and 27mm (just under the 4MHz Xtal marking). I would suggest that you strip some insulation off some single stranded fine hookup wire and bend the wire to fit through the holes allowing sufficient length to pass through the holes and be soldered to the track on the other side of the board. When all the straps are in position it should be easy enough to turn the board over and solder all the straps into position. Any excess wire can be then cut off.

Stage 2.

All the resistors and the two diodes can now be mounted on the top of the board. The two diodes are shown as IN914 but are provided as 1N4148.

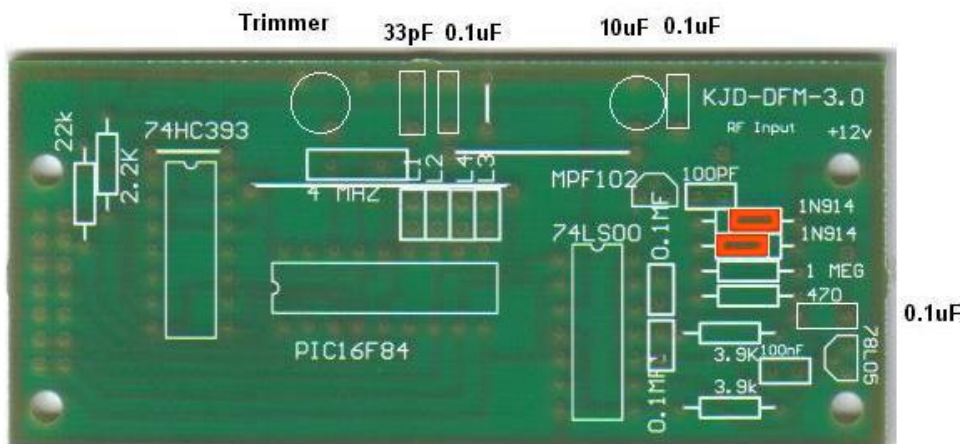

Remember that one diode is shown reversed. Make sure that the two diodes are mounted with their cathodes at opposite ends. It does not matter which diode is reversed as long as they are not mounted with their cathodes in parallel. If you examine the circuit you will see the two diodes in the lower left hand corner of the diagram. They are being used as clippers to prevent over driving of the input circuit. The back to back diodes will limit the peak to peak voltage to 0.7 Volt.

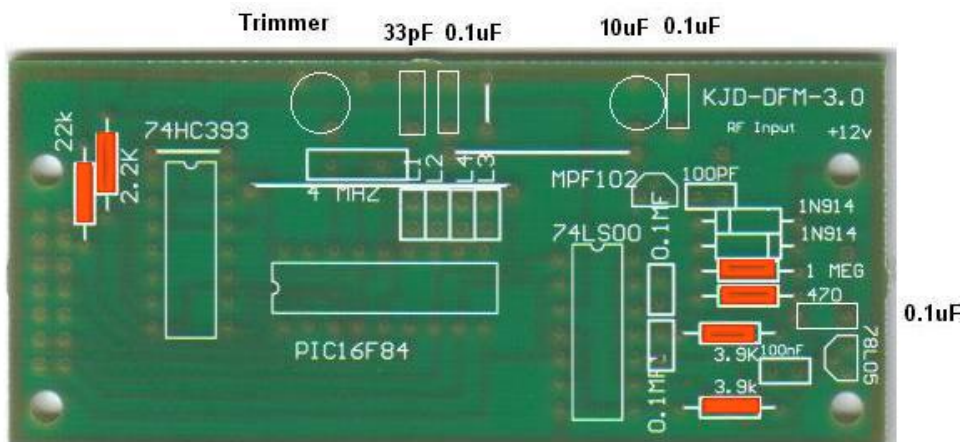

Remember that where a 22K resistor is shown it is to be replaced with a 1K ohm resistor. All other resistors are shown as marked on the top of the board. Most of the components are already shaped with their pigtails bent to pass through the holes in the board. I found that on the prototype board that some of the holes in the board were partially blocked and required a very small drill to allow the pigtail to pass through. I have not had time to examine every board so you will just have to remember that if the component will not pass through the board then check the hole.

Once all the resistors and diodes have been positioned on the board it can be turned over and the components soldered. The excess leads can be trimmed off. By using this method all the resistors and diodes are of the same height so they will be held in position when the board is turned over for soldering.

Stage 3.

The three IC sockets can now be mounted on the board. The two 14 pin sockets are mounted vertically with the identifying cutout for pin 1 to the top of the board. The 18 pin IC socket is mounted with the pin 1 identifying cutout to the left hand side. The board can be turned over and all the pins soldered on to the board. Make sure that only minimum solder is used and that all the pins remain isolated from each other. Double check that your soldering is correct and that no solder has run between pins and made a false connection.

Stage 4.

It is now time to mount the six 0.1 uf capacitors on the board. Only three positions are marked on the board. The other positions will have to be identified. The pigtails for the 0.1uF capacitors may have to be shaped to fit into the three marked positions as they are close spaced.

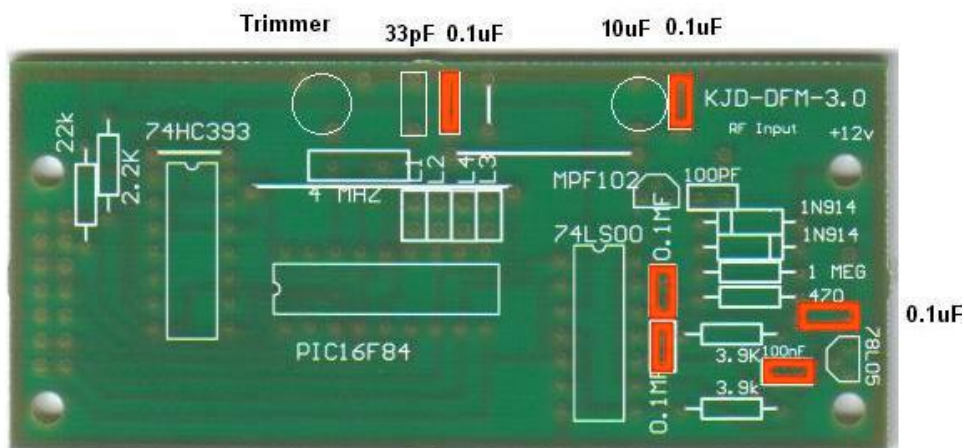

One 0.1uf capacitor is placed through the two holes running horizontal just above the 78L05 regulator

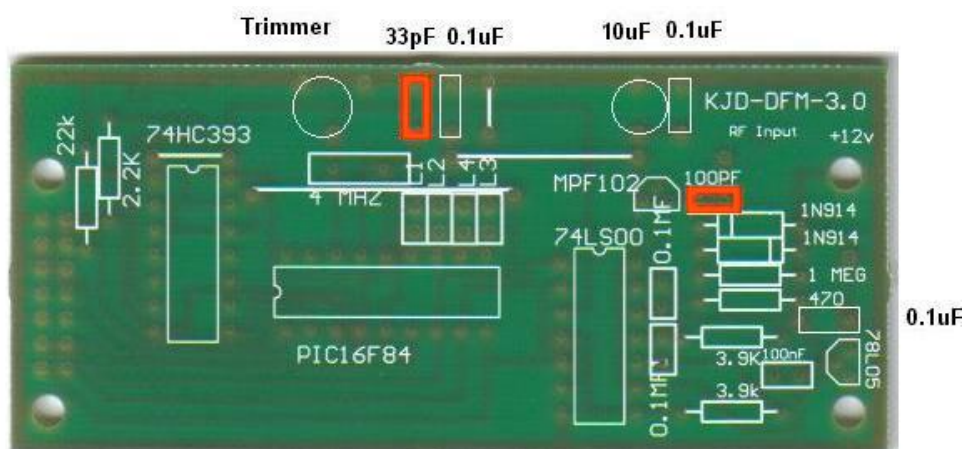

marking and just under the 470 marking. These holes are wide spaced. One 0.1uF capacitor is placed between the two holes to the right of the vertical strap on the top of the board (13mm to the right of the strap) One 0.1uF capacitor is placed through the two holes directly to the left of the vertical strap.

The 100pF disc ceramic capacitor is placed just to the right of the MPF102. The 33pF capacitor is placed to the left of the last 0.1uF capacitor along the top of the board.

Once all the 0.1uF capacitors are placed in position the board can be turned over and the capacitors soldered into position.

Stage 5.

The two sets of four header pins can now be placed in position just above the right hand end of the 18 pin IC socket . This area is shown on the overlay as four small rectangular boxes. Up end the board and solder the eight header pins into position the top set of pins are all connected together and the bottom four pins are connected to pins 10 to 13 of the PIC16F84.

Stage 6.

The 4 MHz Xtal and the 10uF electrolytic capacitor can now be mounted on the board as they are both about the same height. The electrolytic capacitor is mounted along the top of the board through the two holes beside the 0.1uF capacitor just previously mounted. The capacitor is inserted with the positive side towards the bottom of the board with the negative indication along the top edge of the board. These holes should be just to the left of the marking KJD-DFM-3.0 on the top of the board.

The 4 MHz Xtal is mounted just to the left of the set of four header pins. These two components can now be soldered into position.

Stage 7.

The 78L05 regulator and the MPF102 can now be placed in position and soldered on to the board. The lead lengths of these components do not have to be kept very short so they can be mounted just above the board..

Stage 8.

The only component left to be mounted on the top of the board is the trimmer capacitor. There are three holes just above and to the left of the 4 MHz Xtal which will be used to mount the trimmer. The final mounting will be determined by the type of trimmer used. The trimmer supplied has only two

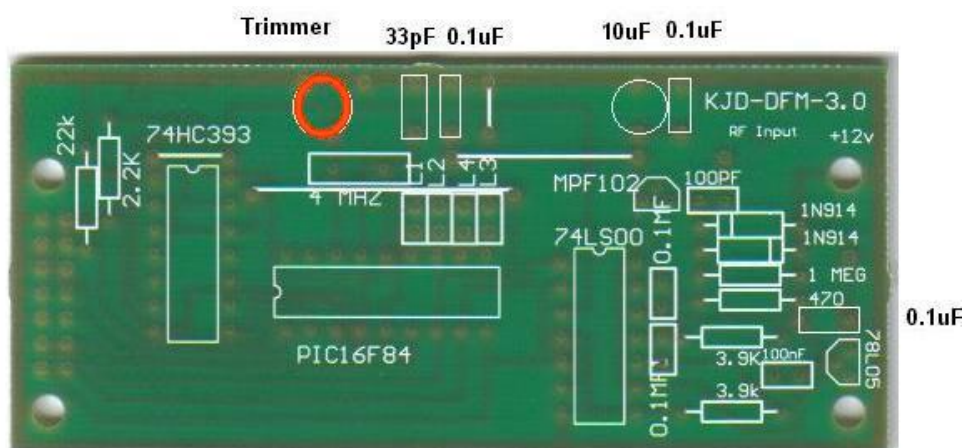

leads 5mm apart. The trimmer is mounted with the flat side towards the Xtal so that when the trimmer is adjusted the earthed end will be in contact with the screwdriver.

Stage 9. Connection to the LCD Display board

The method of connection all depends on your choice of where you wish to place the display with respect to the driver printed circuit board. The first method to be described (Stage 9) is connecting the display directly to the driver board. The method of connection to the board using a piece of ribbon cable and IDE sockets is described in stage 9b so you simply choose which method you wish to use and go to the appropriate section.

Stage 9a Direct Connection

This is possibly the start of the most difficult part of the assembly process. There are two rows of seven holes just to the left of the 74HC393 IC which can be used to interconnect the LCD display closed mounted to the PCB. Before this is done all solder connections need to be rechecked because once the LCD display is connected to the PCB there is no turning back. The display board is mounted with the components facing outwards and the printed circuit track facing the back of the display.

You will have to decide as to how you wish to use and mount the LCD display. The 14 holes in the PCB line up with the 14 connections of the LCD display. If the display is to be used as close as possible to the driver PCB then the following method can be used

Only pins 1 to 6 and 11 to 14 of the LCD display are used so header pins can be used to interconnect the LCD display to the driver board. In the kit are sets of header pins which can be soldered to the driver board so that it marries up with the LCD display. I have tried some ideas as to how to interconnect these two boards and I think that the following method is the simplest.

The LCD display is used as a guide for soldering the header pins on to the driver board. This involves preparing the LCD display board so that it can be anchored into position with a 7mm space between the boards. There are mounting holes in each board for this purpose.

You will need 4 metal screws and nuts 12 mm in length with a suitable thickness to easily pass through the slots in each end of the LCD display board. Four insulated spacers 7mm in length are needed to hold the boards the correct distance apart. I used some suitable spaghetti cut to the required length. My screws were 6BA but I had to slightly enlarge the slots in the ends of the display board.

Once you have found all the above hardware, the sets of header pins can be plugged into the end of the display board. Pin 1 can be identified by the square shape of the pad. The pins start with pin 1 on the inside row when pin 2 on the outside row and continue to number in this order until pin 14 on the outside row down the far end. The header pins have a piece of black insulation which is closest to one end. It is this end that is plugged into the display board.

Use the two sets of three header pins for pins 1 to 6 then use the two sets of two pins for pins 11 to 14. Do not solder these pins on to the display board otherwise you will be in serious trouble and will not be able to solder the inside set of pins on to the driver board. These pins are used as a guide to hold them in position on to the driver board. Use the four screws spacers and nuts to hold the display board in position. The header pins should line up with the holes on the driver board and just finish level with the other side of the board.

When you are satisfied the outside row of five pins are in position on the driver board they can be soldered in position. Take care in soldering not to get too much solder on to the pins. Also make sure they are soldered to the driver board. The pins are gold plated and will allow the solder to take very quickly but you must make sure the pin is soldered to the track on the driver board.

Once the outside set of pins have been soldered in position the display can be removed. This now leaves the job of placing the inner set of pins into position on the driver board and soldering them into place. This is the tricky part. I had difficulty with this stage. One suggested method is to once again use the display board as a guide but this time reverse it around so that the outer row of pins that have been soldered to the driver board line up with the inner set of holes in the display board. To do this the inner set of pins have to be removed and repositioned in the outer set of holes in the display board. The position of the header pins will now finish up with the three set of pins in holes 2,4,6 and the two set of header pins in holes 12 and 14. If two screws and spacers are used at this end of the display the header pins will line up correctly on the driver board and can be soldered into position.

Another method suggested but not tried involves using a small piece of veroboard to hold the two rows of header pins in position for soldering to the display board. The only problem I see with this method is how to hold the veroboard in position.

Yet another idea is to use an alligator clip to clamp the second set of pins parallel to the first set. I also tried and glued one set of pins to the next set to position the second set in position so that I could satisfactorily solder them on to the display board.

Once this part is completed the kit is just about complete. The only thing to do is to double check all solder connections because once the display is mounted and soldered into position there is no way that you can easily get access to the centre of the driver board. It is worth the effort to thoroughly check out the board before proceeding on to the next stage

The display will not work unless all the pins interconnecting the two boards are soldered. I tried by simply plugging in the display board into the header pins but did not get satisfactory results. The only reliable result was with the pins soldered to the display board. Remember that when this is done it cannot be reversed so it is important to ensure everything is correct up to this stage.

The display board is first firmly mounted using the four mounting screws and spacers. It is then time to solder the ten pins into place on the display board.

If you are not certain that everything has been done correctly it would be a good move to do some simple checks before doing the final soldering. This can involve doing some continuity tests to see that all the connections are in place.

Stage 9b. Remote Connection

If you wish to use the LCD display separate from the driver board all that is necessary is to provide a 10 wire cable between the boards. Once again pins 1 to 6 and 11 to 14 are interconnected using a suitable cable. The only thing to watch is that you connect pin1 on the driver board to pin 1 on the display board then follow through with matching the numbering.

A sixteen wire piece of ribbon cable can be used . It is recommended that 16 pin IDC sockets be connected to each end of the cable so that the display can be removed if necessary. There are only 14 pins on the LCD Display where only 10 are used but you will probably have difficulty in trying to purchase a 14 pin IDC socket.

Sixteen pin sockets are available from Dick Smith Electronics as well as Jaycar. Jaycar part number is PS-0985 and can be found on page 88 of the 2003 Catalogue at \$1.35 each. You will need more header pins for the interconnection. These pins are listed as Dual-in-Line Jumpers on page 87 of the Jaycar catalogue. A 40 way (2x20) snap apart unit is part number HM-3250 at \$1.44. Simply snap off two sets of 14 pins and solder one set to the display board and the other set to the driver board.

Remember to identify pin 1 on each board and connect the cable so that the red stripe lines up with pin 1. Pin 1 should be identified by the square pad around the hole in the PCB.

Stage 10.

Testing before inserting the Integrated Circuits and applying power is recommended. This could be done before finally soldering the Display in situ.

If you examine the circuit you will find that the following points are connected to the common ground or negative return for the power supply.

Pin 7 of the 74LS00, pin 7 of the 74HC393, pin 5 of the PICF84.

One side of the 33pf cap, one side of the 33pf trimmer, one side of the four header pins off pins 10 to 13 of the PIC, pin 2 of the LCD display, pin 5 of the display.

One end of the 1 K resistor, one end of the 470 ohm resistor, one end of the 1 megohm resistor, an anode of one diode, a cathode of the other diode.

One side of each of the bypass capacitors (six 0.1uF) plus the negative terminal of the 10uF electrolytic.

The following points should be connected to the +5 volt line.

Drain of the MPF102, pins 13 and 14 and 9 of the 74LS00, pin 14 of the 74HC393, pin 4 and 14 of the PIC16F84, one end of the 2.2 Kohm resistor.

Check that there is no short circuit between the +5 volt line and ground. You should see some resistance through the 78L05 regulator but not a short circuit. Double check that the regulator has been put in correctly with the flat side towards the outside of the board.

If all the above check out okay then you could connect a +12 volt supply to the terminal marked +12 with the negative side connected to a ground point. Apply +12 volts and ensure that you get +5 volts on the +5 volt line. Any one of the above points should do. If all these tests prove satisfactory it is time to turn off the power and do any soldering to the display module.

Stage 11.

You can now insert the Integrated Circuits into their correct sockets. Make sure you line up the pin 1 of the IC with pin 1 of the socket. Remember that the two 14 pin Ics have pin 1 towards the top of the board and the PIC16F84 has pin 1 on the left hand side. Take all the necessary precautions to make sure you are earthed to the board to prevent any static electricity problems.

Stage 12.

It is now time to turn on the power and see if the display indicates anything. If everything has gone according to plan and all connections have been soldered, the display should show the following:- "DMF 3.0 - VK4ZR" for a few seconds then give a display of "0.00000 MHz" There may be some other frequency reading but mainly you should see a display of some sort in MHz. The last two digits may keep varying but this is normal when no input is connected.

The contrast of the display should be quite satisfactory but if it is too dull then the 1Kohm resistor could be lowered in value. If you have any doubts you can short circuit the 1 Kohm resistor for maximum contrast.

If all works as described, the unit is now ready for testing with an input signal. You will need the two insulated straps that short out two header pins for the final setup. One strap is used to short out the header pins connecting pin 13 of the PICF84 to earth.

Final on air testing

Just to refresh your memory I have reprinted part of the article in QSP for December 2002.

I set up the Signal Generator to 5 MHz by using my other frequency counter, and used it as a RF input to the device. I applied the 12 volts and the display showed "DFM3.0 - VK3BHR" for 4 seconds as mentioned in the article. The Display then changed to 5.0015 MHz. My project appeared to work. The 30pf trimmer used for fine tuning of the 4 MHz reference oscillator was adjusted to vary the reading. The next stage was to see how to program the frequency offsets.

The article mentions that pins 10 ,11 ,12 and 13 could be held low by strapping them to earth. The article explains the following:- " Two pins on the PIC (pins 12 and 13) select one of 3 offsets. Pin 11, when pulled low indicates that the local oscillator is on the high side of the received frequency. Finally pin 10 when pulsed low, initiates programming of the selected IF offset frequency. While the offset is being programmed, the RF input must be connected to the receiver BFO oscillator.

For normal operation, the RF input is connected to the receiver's local oscillator and the PIC uses the stored values of the IF offsets to calculate the received frequency. If neither BFO selection pin is pulled low, the PIC calculates the average BFO frequency and uses this to calculate the received frequency. If no offset is required, just measure and store 0 Hz for both offsets (or pull both pins 12 and 13 low to use the third offset)."

I would suggest that the first thing you should do is to adjust the 33pF trimmer capacity to set the local oscillator to exactly 4 MHz so that any frequency reading is accurate. This can be done by setting a signal generator to zero beat with a WWV signal tuned in with a communication receiver. Once you have the signal generator on frequency you can connect it to the RF input of the Digital Counter and adjust the trimmer to get the reading accurate. There may be a slight change in the Xtal oscillator frequency as the temperature changes but this has to be tolerated.

Any I.F. offset can be programmed into the counter simply by shorting pin 13 to earth with the strap then applying a frequency out of the signal generator set to the I.F. eg. 455 KHz then placing a short on pin 10 of the PIC using the other insulated header short strap. The unit has now been programmed for an I.F. of 455 KHz. Remove the short strap from pin 10.

An input frequency applied to the unit will now be shown with a 455 KHz offset either plus or minus depending on the pins strapped to earth.

With pin 12 and 13 earthed the display will show the input frequency (normal Frequency Counter)

For Superhetrodyne Reciever use, the counter monitors the local oscillator and with pin 13 earthed the display will show the input freq minus the I.F. in MHz USB (indicating L.O. above input)
(Indication of tuned input with the local oscillator on the high side)

For Superhetrodyne Reciever use, the counter monitors the local oscillator and with pin 11 and 13 earthed the display will show the input freq plus the I.F. in MHz LSB (indicating L.O. below input)
(Indication of tuned input with the local oscillator on the low side)

For Superhetrodyne receivers the R.F. input to the counter is a sample of the local oscillator of the receiver. In some instances if the local oscillator is low level, a small preamp may be necessary. A very small coupling capacitor to the local oscillator may be necessary to prevent the counter from loading the local oscillator and causing it to change frequency.

USES FOR THE DFM PIC PROJECT

The latest Club project of building a digital Frequency Meter using a PIC Microprocessor has been well received. Fourteen club members now have kits so it is time to explain how the kit can be used for various tasks around the shack.

The main purpose of the kit was to provide a digital display for a superhetrodyne receiver that only has an analogue tuning dial. The kit provides a means of using the local oscillator of the receiver to provide an input to the counter. An offset frequency can be programmed into the counter so that the display can indicate the receiver's input tuned frequency by either adding the offset or subtracting the offset from the receiver's local oscillator.

The counter can be set up with three options simply by changing the straps connecting pins 10, 11, 12 and 13 to earth.

With 12 and 13 earthed the counter reads the input frequency without any correction.

With 13 earthed and pin 10 momentary earthed an offset frequency can be programmed into the counter. Eg. An IF of 455 KHz can be programmed into the PIC by connecting a frequency of 455 KHz to the counter then earthing pin 10 for a short time. The offset frequency will remain in the PIC program until a new frequency is selected.

With pin 13 earthed the counter will subtract the offset frequency from the input frequency eg. Offset frequency of 455 KHz input frequency of receiver local oscillator of 1.2 MHz the counter will read 745 KHz ($1.2 \text{ MHz} - 455 \text{ KHz}$) and indicate USB (oscillator on high side)

With pin 13 and pin 11 earthed the counter will add the offset frequency to the input frequency. Eg. Offset frequency of 455 KHz, input frequency of receiver local oscillator of 1.2 MHz, the counter will read 1.655 MHz ($1.2 \text{ MHz} + 455 \text{ KHz}$) and indicate LSB (oscillator on the low side)

The counter has a resolution of 10 Hz so it can be used to read any input frequency up to 30 MHz with a resolution of 10 Hz. Simply by strapping pin 13 and pin 12 to earth. An example is connecting the counter to a signal generator which produces an output up to 30 MHz but with an analogue tuning dial which is inaccurate.

By coupling the counter to a Dip Oscillator by using a few turns wound around the base of one of the plug in coils the counter will indicate the Dip Oscillator's frequency with an accuracy of 10 Hz.

The sensitivity of the counter can be improved if necessary by building a simple broadband amplifier circuit using one transistor connected as a common emitter amplifier with a very low value of collector load.

If you wish to improve the frequency limit of the counter, the 74LS00 I.C. can be replaced with a 74HS00 I.C. This should allow the counter to work above 40 MHz.

The counter will show a reading with no input connected because of the 74LS00 or 74HS00 will attempt to run at full gain and break into oscillation. Once a signal is connected to the input the circuit will stabilize and give a correct reading.

The LCD Display does have a backlight facility but it must be run from a separate 5 Volt supply. The 78L05 will overheat if the existing 5 volt supply is used. It is recommended that the 5 volt supply is derived by using a 5 watt 100 ohm resistor from the +12 volt supply.

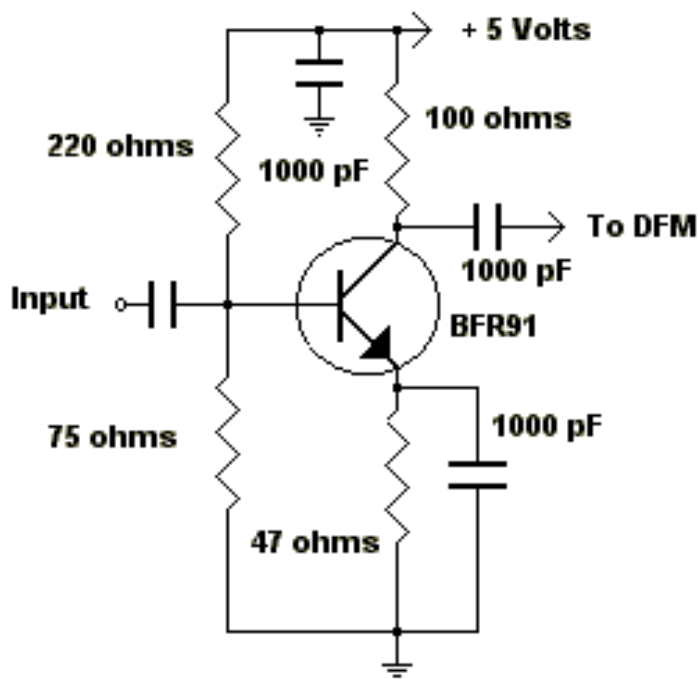

If you examine the LCD Display you will notice that at the other end of the display board to the 14 pin connection there are two tracks marked + 5V -. Simply earth the - ve terminal and connect the 100 ohm resistor to the +5V track. The display will be backlit showing a yellow green colour. The LED backlight assembly draws up to 200 mA so make sure the supply used is capable of supplying the necessary current.

The Frequency Counter will run off a small 9 volt battery for portable use but the backlight facility should only be connected when the unit is run off a 12 volt supply that can deliver the extra current for the LED backlight.