

APPLICATION NOTE

AN1995

Evaluating the SA605 SO and SSOP
demo-board

Alvin K. Wong

1997 Oct 29

Philips Semiconductors



PHILIPS

Evaluating the SA605 SO and SSOP demo-board

AN1995

Author: Alvin K. Wong

INTRODUCTION

With the increasing demand for smaller and lighter equipment, designers are forced to reduce the physical size of their systems. There are several approaches to solving the size problem. A designer needs to look for sophisticated integrated single chip solutions, chips that are smaller in size, and chips that require minimum external components.

Philips Semiconductors offers all of these solutions in their SA605. The SA605 single-chip receiver converts the RF signal to audio and is available in three packages: DIP,SO, and SSOP. This offers total flexibility for layout considerations. The SSOP package is the smallest 20 pin package available in the market today, and allows the designer the flexibility to reduce the overall size of a layout.

When working with a smaller and tighter layout in a receiver design, it becomes important to follow good RF techniques. This application note shows the techniques used in the SO and SSOP demo-board. It does not cover the basic functionality of the SA605 but instead focuses more on the layout constraints. This application note also has a trouble-shooting chart to aid the designer in evaluating the SO and SSOP demo-board. For a complete explanation of the SA605, please refer to application note AN1994 which describes the basic block diagrams, reviews the common problems encountered with the SA605, and suggests solutions to them. Reading AN1994 is highly recommended before attempting the SO and SSOP layout.

The recommended layout demonstrates how well the chip can perform. But it should be pointed out that the combination of external parts with their tolerances plays a role in achieving maximum sensitivity.

The minimum and maximum 12dB SINAD measurement for both boards is -118dBm and -119.7dBm, respectively. A typical reading taken in the lab for both SO and SSOP demo-boards is -119dBm.

There were two different design approaches for both layouts. For the SO layout, there are inductive tuning elements (except for the LO section); for the SSOP layout there are capacitive tuning elements. This approach was taken to show the designer that both ways can be used to achieve the same 12dB SINAD measurement. However, it is worth mentioning that capacitive tuning elements are less expensive than the inductive tuning elements.

Packages Available

As mentioned above, there are three packages available for the SA605. See the "Package Outline" section of the Philips Semiconductors 1992 RF Handbook for the physical dimensions of all three packages. Notice that the DIP package is the largest of the three in physical size; the SSOP is the smallest. The recommended layout and performance graphs for the DIP package are shown in the SA605 data sheet and AN1994. But the SO and SSOP recommended layout and performance graphs are shown in this application note.

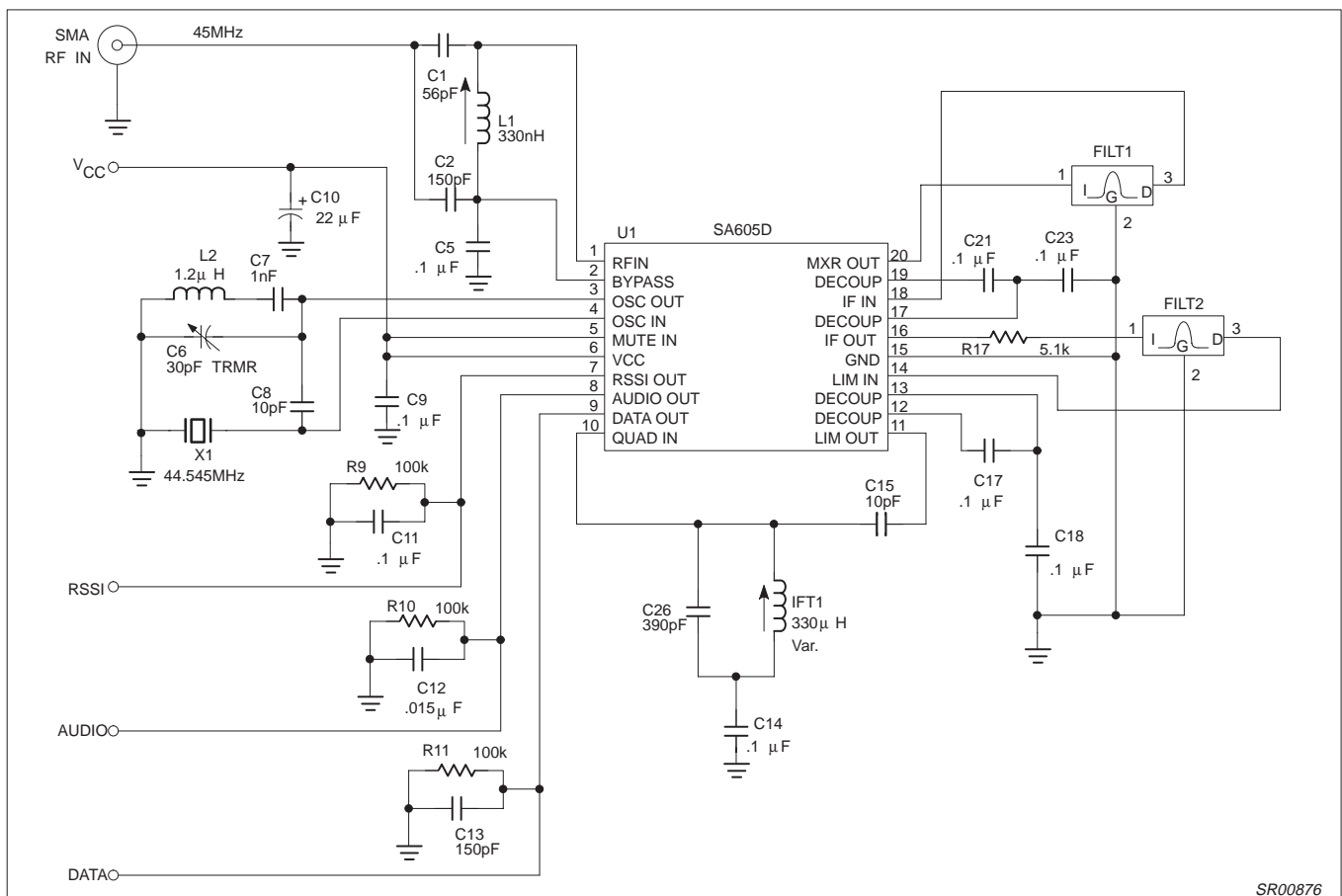

Figure 1. SA605 Schematic for the SO Layout

SR00876

Evaluating the SA605 SO and SSOP demo-board

AN1995

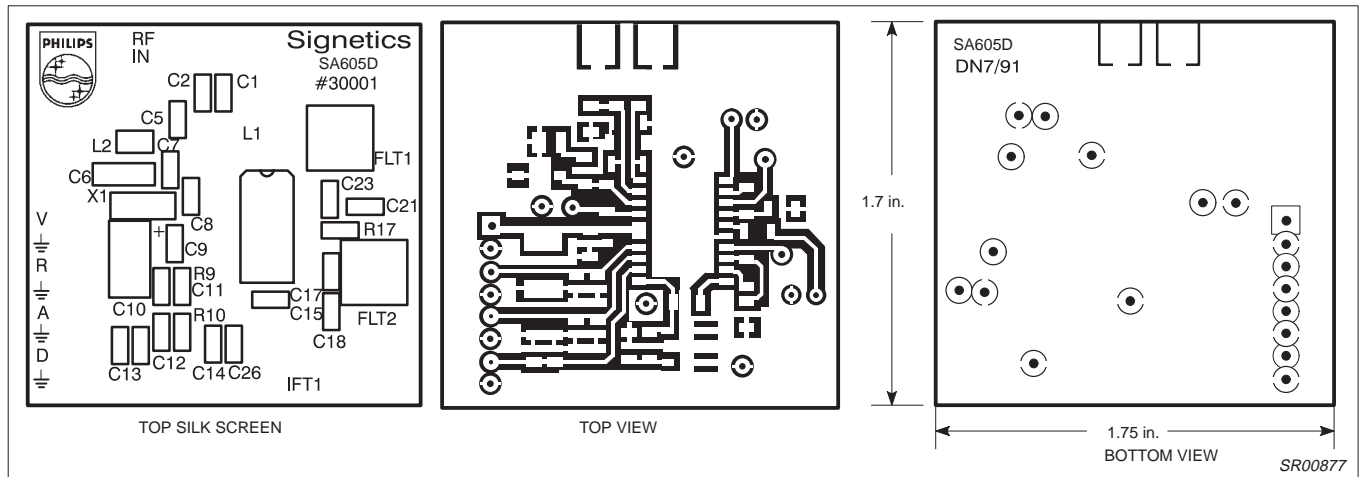

Figure 2. SA605 SO Demo-board Layout (Not Actual Size)

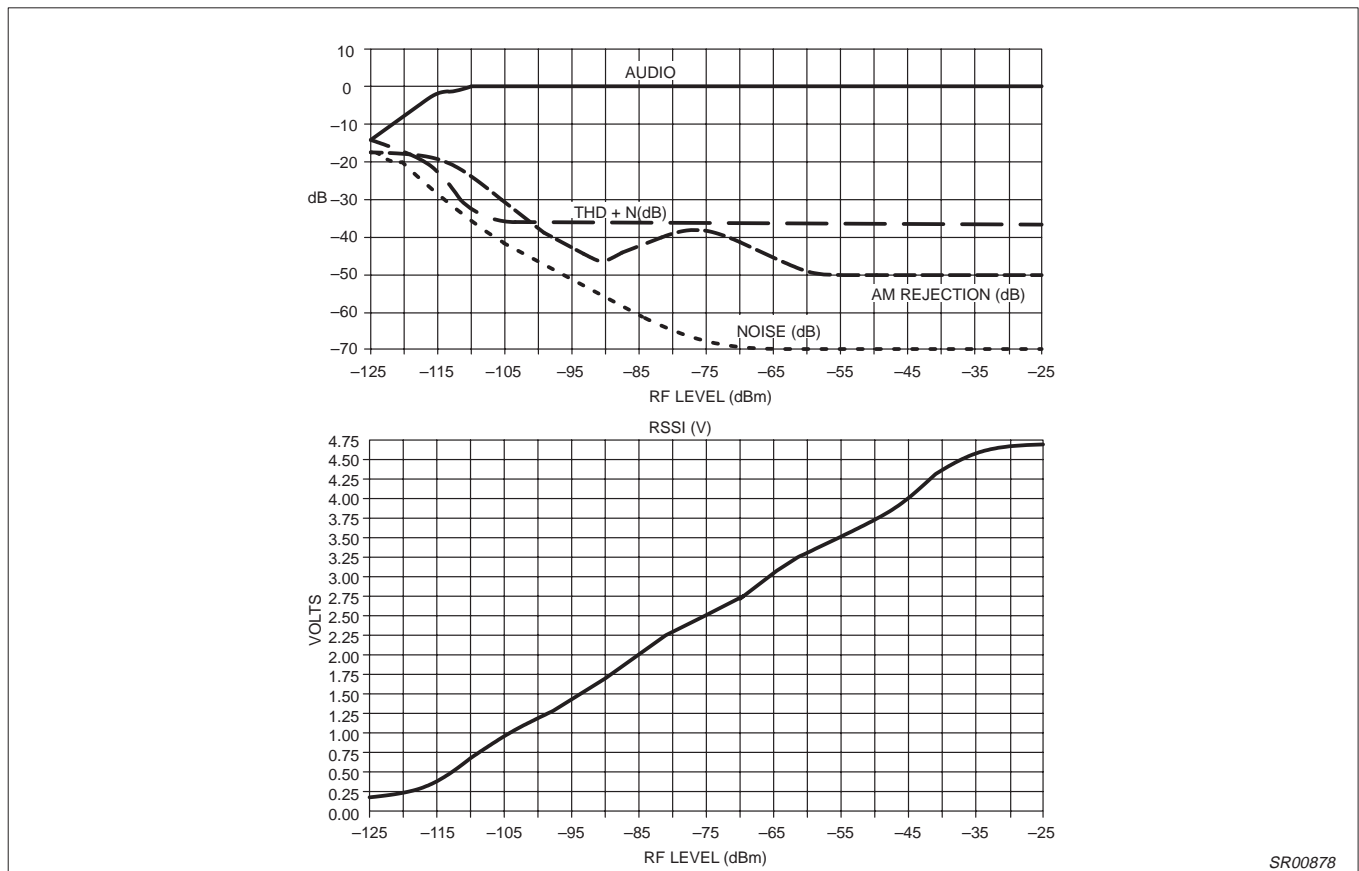

Figure 3. SA605 SO Performance Curves

SO LAYOUT:

Figure 1 shows the schematic for the SO layout. Listed below are the basic functions of each external component for Figure 1.

- C1 – Part of the tapped-C network to match the front-end
- C2 – Part of the tapped-C network to match the front-end
- C5 – Used as an AC short to Pin 2
- C6 – Used to tune the LO for the Colpitts oscillator

- C7 – Used as part of the Colpitts oscillator
- C8 – Used as part of the Colpitts oscillator
- C9 – Supply bypassing
- C10 – Supply bypassing
- C11 – Used as filter
- C12 – Used as filter

Evaluating the SA605 SO and SSOP demo-board

AN1995

- C13 – Used as filter
- C14 – Used to AC ground the Quad tank
- C15 – Used to provide the 90° phase shift to the phase detector
- C17 – IF limiter decoupling cap
- C18 – IF limiter decoupling cap
- C21 – IF amp decoupling cap
- C23 – IF amp decoupling cap
- C26 – Quad tank component
- L1 – Part of tapped-C network to match the front-end TOKO 5CB-1320Z
- L2 – Part of the Colpitts oscillator Coilcraft 1008CS-122
- R9 – Used to convert the current into the RSSI voltage

- R10 – Converts the audio current to a voltage
 - R11 – Converts the data current to a voltage
 - R17 – Used to achieve the -12dB insertion loss
 - IFT1 – Inductor for the Quad tank TOKO 303LN-1130
 - FILT1 – Murata SFG455A3 455kHz bandpass filter
 - FILT2 – Murata SFG455A3 455kHz bandpass filter
 - X1 – Standard 44.545MHz crystal in QC38 package
- The recommended SO layout can be found in Figure 2 and should be used as an example to help designers get started with their projects.
- The SO SA605 board performance graphs can be found in Figure 3.

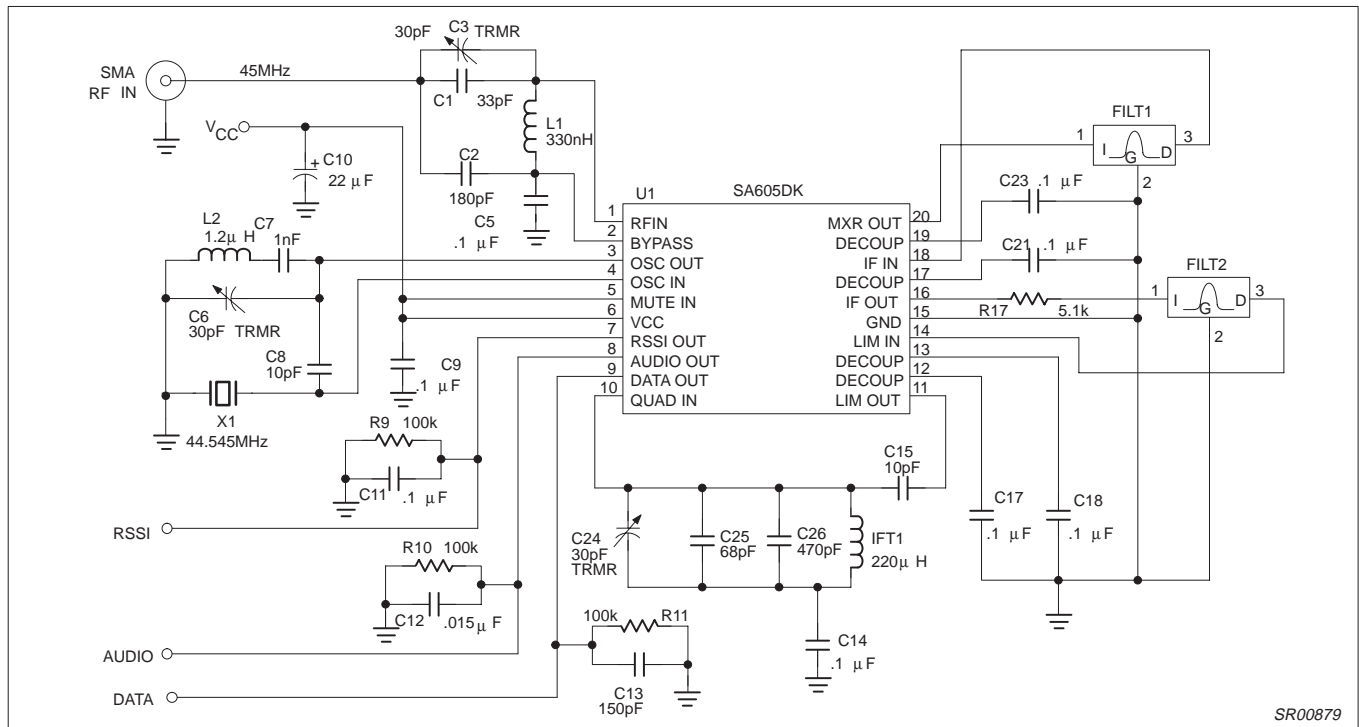

Figure 4. SA605 Schematic for the SSOP Layout

SSOP LAYOUT:

Figure 4 shows the schematic for the SSOP layout.

- C1 – Part of the tapped-C network to match the front-end
- C2 – Part of the tapped-C network to match the front-end
- C3 – Part of the tapped-C network to match the front-end
- C5 – Used as an AC short to Pin 2
- C6 – Used to tune the LO for the Colpitts oscillator
- C7 – Used as part of the Colpitts oscillator
- C8 – Used as part of the Colpitts oscillator
- C9 – Supply bypassing
- C10 – Supply bypassing
- C11 – Used as filter
- C12 – Used as filter
- C13 – Used as filter

- C14 – Used to AC ground the Quad tank
- C15 – Used to provide the 90° phase shift to the phase detector
- C17 – IF limiter decoupling cap
- C18 – IF limiter decoupling cap
- C21 – IF amp decoupling cap
- C23 – IF amp decoupling cap
- C24 – Part of the Quad tank
- C25 – Part of the Quad tank
- C26 – Part of the Quad tank
- L1 – Part of tapped-C network to match the front-end Coilcraft 1008CS-331
- L2 – Part of the Colpitts oscillator Coilcraft 1008CS-122
- R9 – Used to convert the current into the RSSI voltage
- R10 – Converts the audio current to a voltage

Evaluating the SA605 SO and SSOP demo-board

AN1995

- R11 – Converts the data current to a voltage
- R17 – Used to achieve the -12dB insertion loss
- IFT1 – Inductor for the Quad tank Mouser ME435-2200
- FILT1 – Murata SFGCC455BX 455kHz bandpass filter
- FILT2 – Murata SFGCC455BX 455kHz bandpass filter
- X1 – Standard 44.545MHz crystal

The SSOP layout can be found in Figure 5. The SSOP SA605 board performance graphs can be found in Figure 6.

The main difference between the SO and SSOP demo-boards is that the SSOP demo-board incorporates the low profile 455kHz Murata ceramic filter. It has an input and output impedance of 1.0kΩ. This presents a mismatch to our chips, but we have found that the overall performance is similar to that when we use the "blue" Murata filters that have the proper 1.5kΩ input and output impedance.

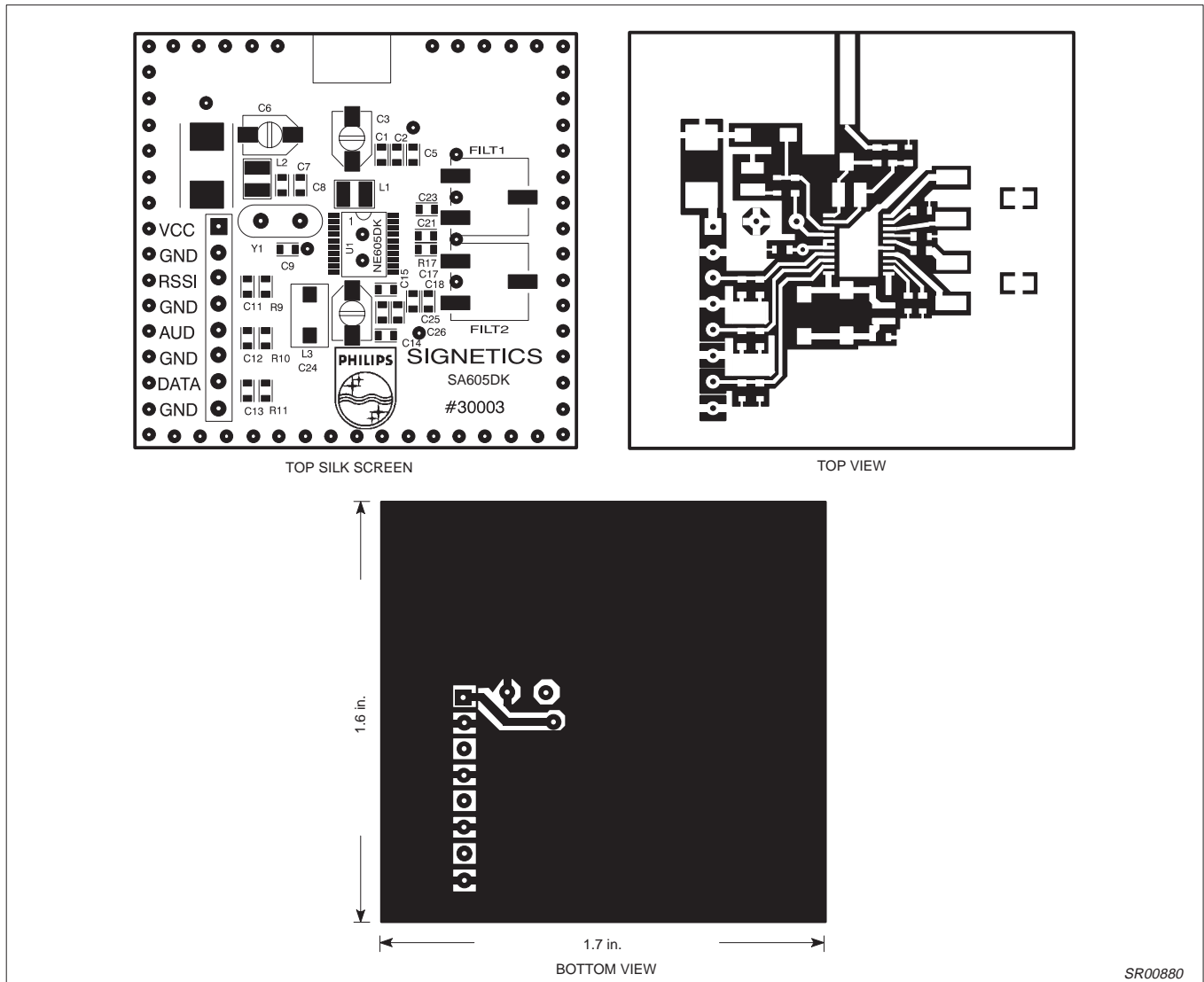

Figure 5. SA605 SSOP Demo-board Layout (Not Actual Size)

SR00880

Evaluating the SA605 SO and SSOP demo-board

AN1995

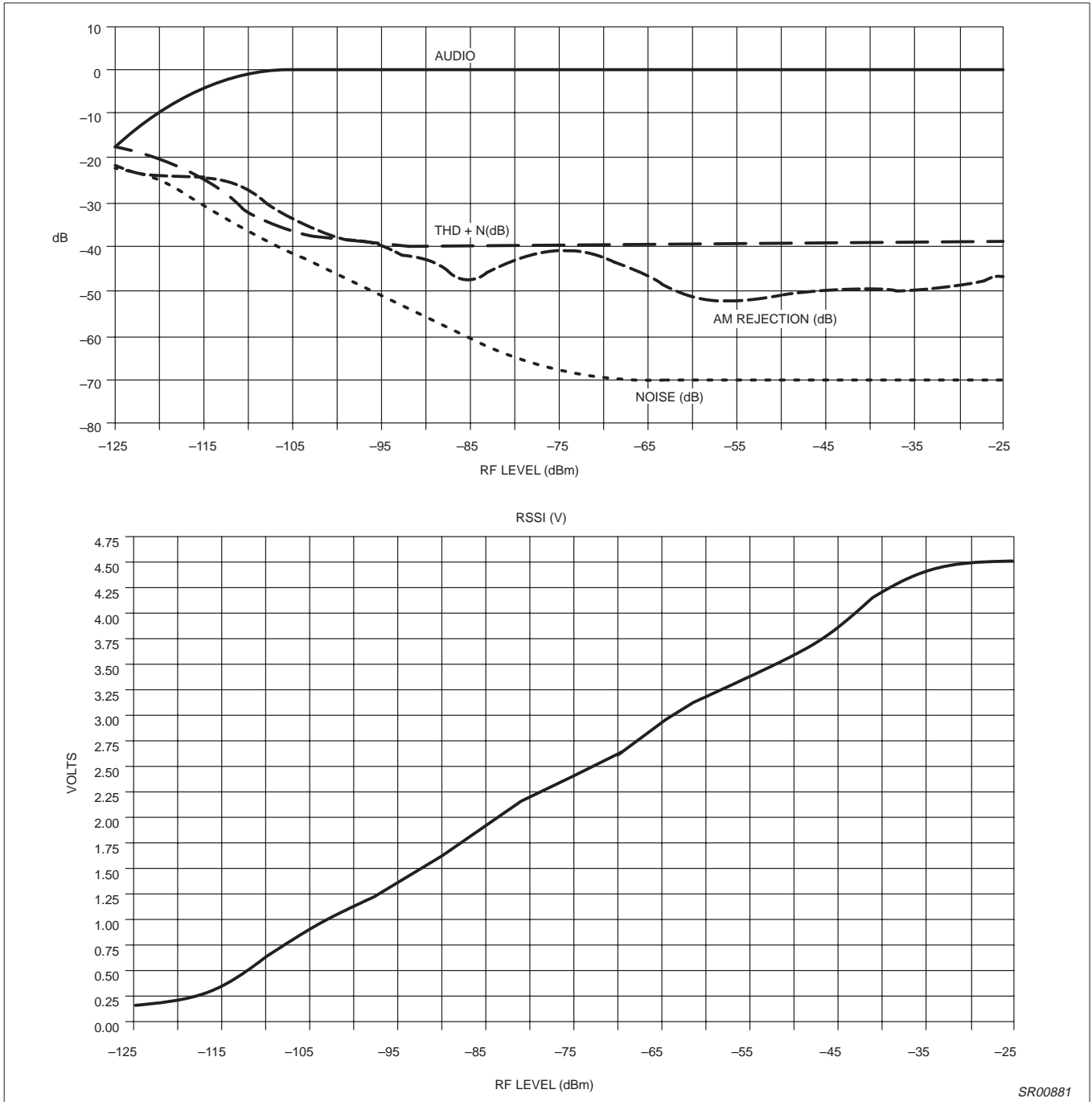

Figure 6. SA605 SSOP Performance Graphs

SR00881

Evaluating the SA605 SO and SSOP demo-board

AN1995

HOW TO TUNE THE SA605 DEMO-BOARD

Figure 7 shows a trouble-shooting chart for the SA605. It can be used as a general guide to tune the DIP, SO, and SSOP

demo-boards. Below are some of the highlights from the trouble shooting chart that are explained in more detail.

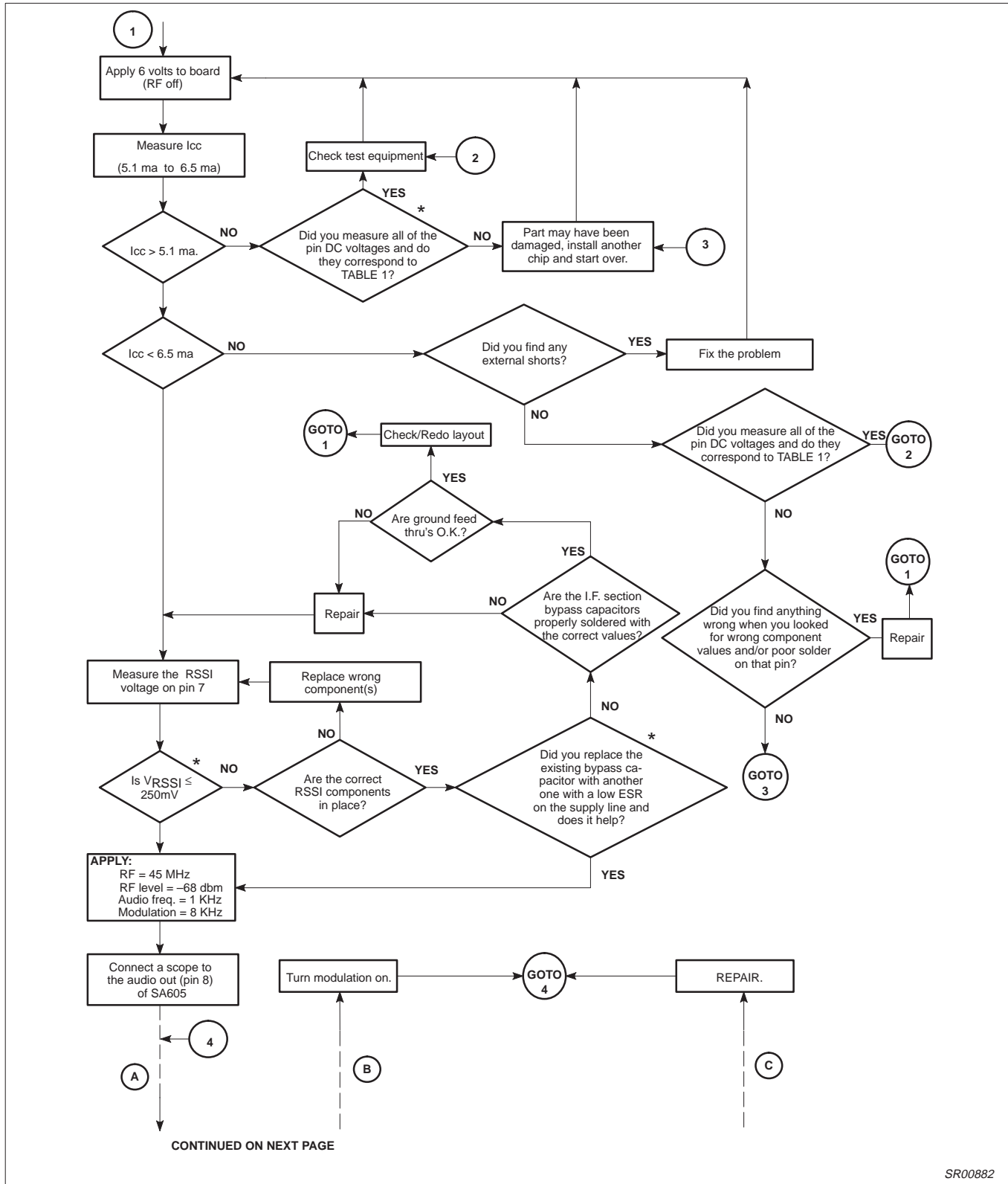
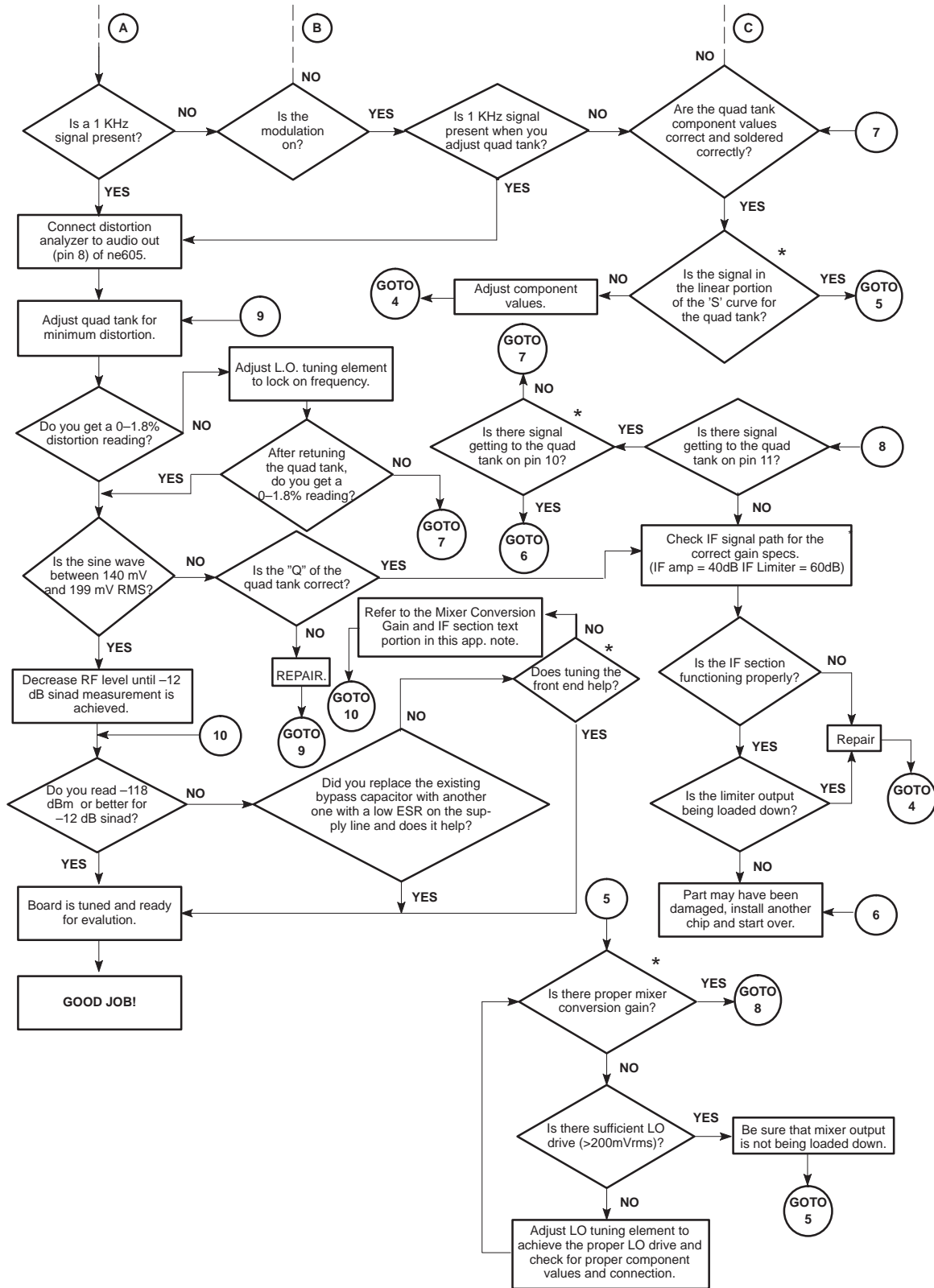

Figure 7. Trouble-shooting Chart for the SA605 Demo-board

Evaluating the SA605 SO and SSOP demo-board

AN1995



*NOTE: Refer to the appropriate text section of the app. note for further details.

SR00883

Evaluating the SA605 SO and SSOP demo-board

AN1995

How to tell when a part is damaged

Since most SO and SSOP sockets hinder the maximum performance of the SA605, it is advisable to solder the packages directly to the board. By this approach, one will be able to evaluate the part correctly. However, it can be a tedious chore to switch to another part using the same layout. Therefore, to be absolutely certain that the chip is damaged, one can measure the DC voltages on the SA605. Table 1 shows the DC voltages that each pin should roughly have to be a good part.

Table 1. Approximate DC Voltages for the SA605

Pin Number	DC Voltage (V)
1	1.37
2	1.37
3	5.16
4	5.94
5	N/A
6	6.00 (V _{CC})
7	N/A
8	2.00
9	2.00
10	3.49
11	1.59
12	1.59
13	1.59
14	1.65
15	0.00 (GND)
16	1.60
17	1.60
18	1.60
19	1.60
20	4.87

Note: The DC voltage on Pin 5 is not specified because it can either be V_{CC} or ground depending if the audio is muted or not (Connecting ground on Pin 5 mutes the audio on Pin 8, while V_{CC} on Pin 5 unmutes the audio).

The DC voltage on Pin 7 is not specified because its DC voltage depends on the strength of the RF signal getting to the input of the SA605. It also can be used as a stability indicator.

If any of the DC voltages are way off in value, and you have followed the trouble-shooting chart, the part needs to be changed.

RSSI Indicator

The next important highlight is using the RSSI pin as a stability indicator. With power connected to the part and no RF signal applied to the input, the DC voltage should read 250mV or less on Pin 7. Any reading higher than 250mV, indicates a regeneration problem. To correct for the regeneration problem, one should check for poor layout, poor bypassing, and/or poor solder joints. Bypassing the SA605 supply line with a low equivalent series resistance (ESR) capacitor to reduce the RSSI reading can improve the 12dB SINAD measurement by 8dB, as found in the lab. If the regeneration problem still exists, read AN1994.

Quad tank and S-Curve

As briefly mentioned in the chart, it is important to measure the Q of the quad tank if a distortion reading of 1.8% or less cannot be measured. Recall that if the Q of the quad tank is too high for the deviation, then premature distortion will occur. However, if the Q is too low for the deviation, the audio level will be too low. The audio level coming out of the audio pin should be 140mV_{RMS} to 190mV_{RMS}.

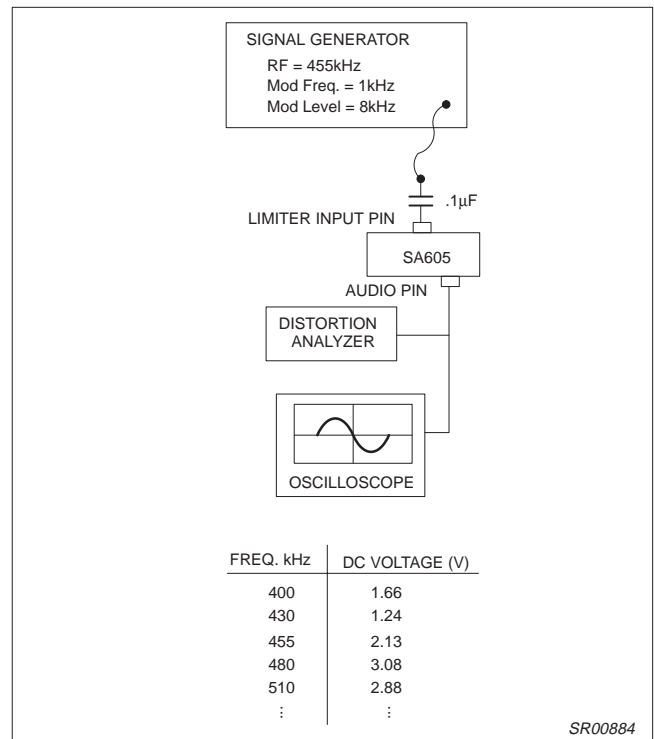

Figure 8. Test Set-up to Measure S-Curve of the Quad Tank

If the distortion reading is too high and/or the audio level is too low, then it is important to measure and plot the S-curve of the quad tank. The test set-up used in the lab can be seen in Figure 8.

The following steps were taken to measure the S-curve for the SO and SSOP demo-boards.

- Step 1.** Remove the second IF ceramic filter from the demo-board.
- Step 2.** Connect a signal generator to the limiters input through a DC blocking capacitor.
- Step 3.** Connect a DC voltmeter and an oscilloscope to the audio output pin.
- Step 4.** Set the signal generator to a 455kHz signal and be sure that the modulation is on (RF=455kHz Mod Freq = 1kHz Mod Level=8kHz). Apply this 455kHz signal to the limiter input such that there is a sinewave on the oscilloscope screen. Adjust the quad tank for maximum sinewave amplitude on the oscilloscope or for lowest distortion. Additionally, adjust the supply input signal to the SA605 such that the 1kHz sinewave reaches its maximum amplitude.

Evaluating the SA605 SO and SSOP demo-board

AN1995

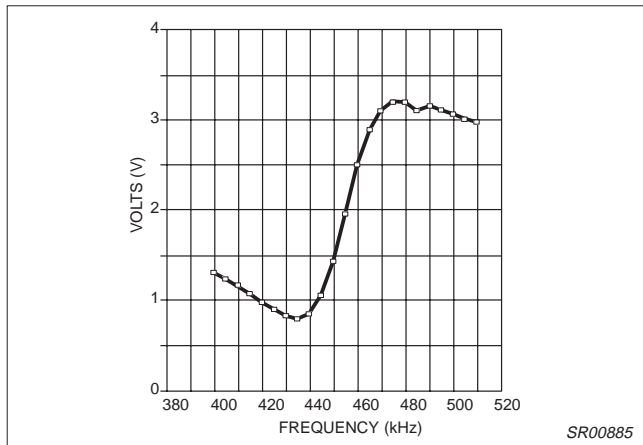

Figure 9. S-Curve for SA605 SO Demo-board

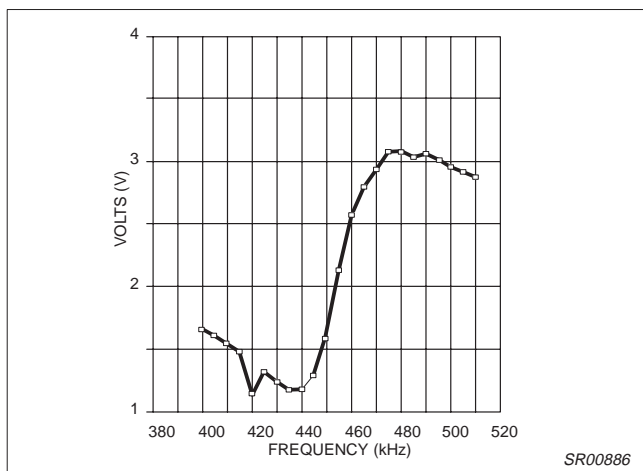

Figure 10. S-Curve for SA605 SSOP Demo-board

Step 5. Turn off the modulation and start taking data. Measure the Frequency vs DC voltage. Vary the frequency incrementally and measure the DC voltage coming out of the audio pin. Remember that once the modulation is turned off, the sine-wave will disappear from the oscilloscope screen.

Step 6. Plot the S-curve.

Figures 9 and 10 show the S-curve measurements for the SO and SSOP demo-boards. Notice that the center of the S-curve is at 455kHz. The overall linearity determines how much deviation is allowed before premature distortion. Since our application requires ± 8 kHz of deviation, our S-curve is good because it exceeds the linear range of 447kHz to 463kHz.

If the Q of the quad tank needs to be lowered, a designer should put a resistor in parallel with the inductor. The lower the resistor value, the more the Q will be lowered. If the Q needs to be increased, choose a higher Q component. More information on the Quad tank can be found in the SA604A data sheet.

If the linear section of the S-curve is not centered at 455kHz, the quad tank component values need to be recalculated. The way to determine the component values is by using $F = \frac{1}{2\pi\sqrt{LC}}$ where F

should be the IF frequency. In the case of the demo-boards, the IF = 455kHz.

Front End Tuning

The best way to tell if the front end of the SA605 is properly matched is to use a network analyzer in a S11 setting. The lower the dip, the greater the absorption of the wanted frequency. Figures 11 and 12 show the S11 dip for the front end matching of the SO and SSOP demo-boards, respectively.

We have found in the lab that a -8dB to -10dB dip is usually sufficient to get the maximum signal transfer such that a good 12dB SINAD reading is met. The front end circuit uses a tapped-C impedance transformation circuit which matches the 50Ω source with the input impedance of the mixer.

In the process of matching the front end, we have found that the ratio of the two capacitors play an important role in transferring the signal from the source to the mixer input. There should be approximately a 4:1 or 5:1 ratio.

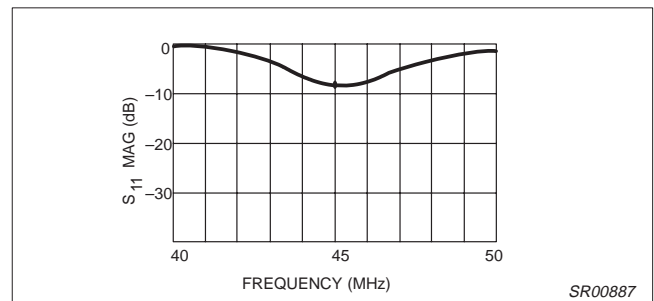

Figure 11. S11 Front-End Response for SO Demo-board

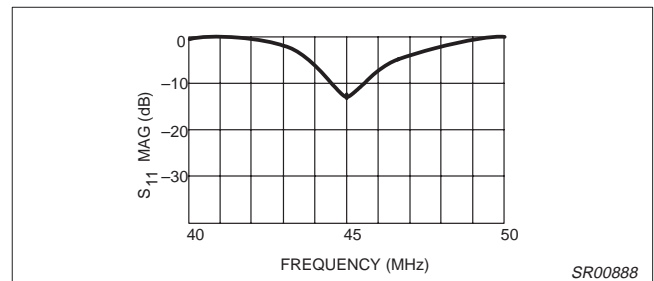

Figure 12. S11 Front-End Response for SSOP Demo-board

Checking the Conversion Gain of the Mixer

Once the front end has been properly matched, a designer should check the conversion gain if there are problems with the SINAD measurement. Be sure to turn off the modulation when making this measurement.

The method of measuring conversion gain on the bench is fairly simple. For our demo-boards, measure the strength of the 455kHz signal on the matching output network of the mixer with a FET probe. Then measure the 45MHz RF input signal on the matching input network of the mixer. Subtract the two numbers and the measured conversion gain should be around 13dB. Make sure that the input and output matching networks for the mixer have the same impedance since we are measuring voltage gain to get power gain ($P = V^2/R$). Of course this conversion gain value will change if there is a different RF input. In AN1994, Figure 16 shows how the conversion gain varies with different RF input frequencies.

Evaluating the SA605 SO and SSOP demo-board

AN1995

Checking the gains in the IF Section

If the IF section does not give 100dB of gain, then the -118dBm SINAD measurement cannot be achieved. In fact some symptoms of low or no audio level can be due to the IF section.

One way of checking the function of the IF section is to check the gain of the IF amplifier and the IF limiter. The IF amplifier gain should be around 40dB and the IF limiter gain should be around 60dB.

To check this, connect a FET probe to the output of the amplifier. Apply a strong input signal with no modulation and then slowly lower the input signal and wait for the output of the amplifier to decrease. Measure the strength of the output signal in dB and then subtract from it the strength of the input signal in dB. This resulting number indicates the maximum gain of that section. (This method assumes matched input and output impedance.)

If a designer finds one of the sections with lower gain, then one area to check are the IF bypass capacitors. Be sure that the IF bypass capacitors have a good solid connection to the pad. It was also found in the lab that the RSSI stability reading improves when the IF bypass is properly installed.

QUESTION & ANSWER SECTION

Q: When I measure the bandpass response of the IF filters on the SSOP demo-board, it appears to have a little hump compared to the SO demo-board which has a flat filter response. Why is there a difference in the bandpass response when the SO and SSOP 605 chips are similar?

A: The answer has to do with the ceramic filters and not the package of the SA605. The reason why the SO demo-board has a flat bandpass response is because it is matched properly with the filter. The SSOP demo board uses the new Murata low profile ceramic 455kHz filter. Unfortunately, the input and output impedance is now 1k Ω instead of 1.5k Ω . This presents an impedance mismatch which creates the hump to occur in the bandpass response. But one does not have to worry too much about this response because the situation does not affect the overall performance that much. Additionally, the 12 SINAD measurement is similar whether using the "blue" (1.5k Ω) or "white" (1.0k Ω) Murata filters.

If you are worried about this, then switch to the correct "blue" Murata filters. The SSOP package will work with those filters as well. But if your design has strict height requirements, the white filters are a good solution.

Q: How much LO signal do you see at the RF port?

A: The worst LO leakage seen at the RF input on the SO and SSOP demo-board is -40dBm/441mV. This seems to vary with the LO level into the base of the on board transistor. This measurement will also vary with different LO frequencies. The SA605 SO and SSOP demo-boards have a LO frequency of 44.545MHz. Since there are so many variables, a designer needs to measure his/her own board for an accurate LO-RF isolation measurement.

There are several ways to improve the LO leakage from getting to the antenna. One can choose a higher IF frequency and tighten up the bandwidth of the front-end filter. Another solution is to add a low noise amplifier between the antenna and the mixer, and/or design a double conversion receiver and make sure the 1st mixer has a LO-RF isolation which meets the system specifications.

Q: On the SO and SSOP demo-board, the LO oscillator circuit is tunable with a variable capacitor. Is this a requirement?

A: No. The variable capacitor is used to tune the LO freq., but one can use a fixed value. The advantage of going with a fixed value capacitor is that it is a cheaper component part and there is no need for tuning. The only advantage with a tunable LO is that a designer can optimize the performance of the receiver.

Q: I know that the IF bandwidth of the SA605 allows me to build an IF of 21.4MHZ. Will the SA605 SSOP package perform just as good at 21.4MHz IF as it does at 455kHz?

A: Although we have not worked with SA605 SSOP at 21.4MHZ, we believe that it would be difficult to get a 12dB SINAD measurement at -120dBm. The wavelengths are much smaller at 21.4MHz than 455kHz. Since the wavelengths are smaller, there is a higher probability of regeneration occurring in the IF section. Therefore, a designer will probably have to reduce the gain in the IF section. Additionally, the SSOP package has pins that are physically closer together than with the normal type of packaged parts which can contribute to the unstable state with higher IF frequencies.