

TYPES SN7404, SN74LS04, SN74S04
SN5404, SN54LS04, SN54S04
HEX INVERTERS

REVISED DECEMBER 1983

- Package Options include Standard Plastic (N) and Ceramic (J) 300-mil Dual-In-Line Packages, Plastic Small Outline (D) and Ceramic Chip Carrier (FK) Package
- Dependable Texas Instruments Quality and Reliability

description

These devices contain six independent inverters.

The SN5404, SN54LS04 and SN54S04 are characterized for operation over the full military temperature range of -55°C to 125°C. The SN7404, SN74LS04 and SN74S04 are characterized for operation from 0°C to 70°C.

FUNCTION TABLE (each inverter)

INPUTS		OUTPUT	
A		Y	
H		L	
L		H	

logic diagram (each inverter)



positive logic

$$Y = \bar{A}$$

SN5404, SN54LS04, SN54S04 ... J PACKAGE
SN7404 ... N PACKAGE
SN74LS04, SN74S04 ... D OR N PACKAGE
(TOP VIEW)

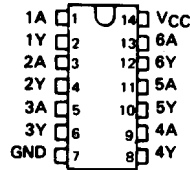

SN54LS04, SN54S04 ... FK PACKAGE

(TOP VIEW)

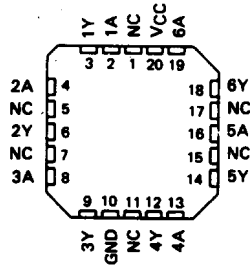

NC - No internal connection

PRODUCTION DATA

This document contains information current as of publication date. Products conform to specifications per the terms of Texas Instruments standard warranty. Production processing does not necessarily include testing of all parameters.



**TYPES SN7404, SN74LS04, SN74S04
SN5404, SN54LS04, SN54S04
HEX INVERTERS**

schematics (each gate)

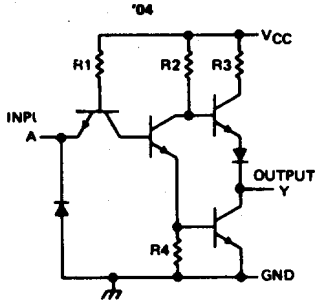

CIRCUIT	R1	R2	R3	R4
'04	4 kΩ	1.6 kΩ	130 Ω	1 kΩ

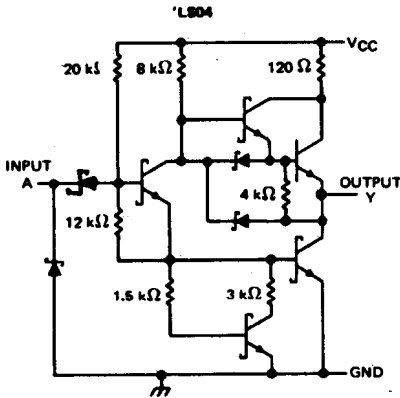

Resistor values shown are nominal.

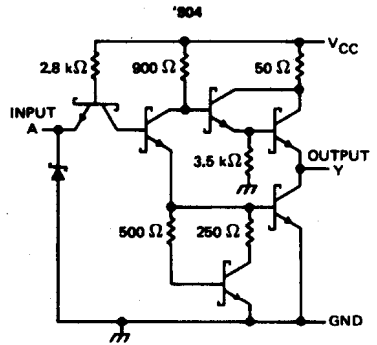

absolute maximum ratings over operating free-air temperature range (unless otherwise noted)

Supply voltage, V _{CC} (see Note 1): '04, 'LS04, 'S04	7 V
Input voltage: '04, 'S04	5.5 V
'LS04	7 V
Operating free-air temperature range: SN54'	-55° C to 125° C
SN74'	0° C to 70° C
Storage temperature range	-65° C to 150° C

NOTE 1: Voltage values are with respect to network ground terminal.

TYPES SN7404, SN5404
HEX INVERTERS

recommended operating conditions

	SN5404			SN7404			UNIT
	MIN	NOM	MAX	MIN	NOM	MAX	
V _{CC} Supply voltage	4.5	5	5.5	4.75	5	5.25	V
V _{IH} High-level input voltage	2			2			V
V _{IL} Low-level input voltage			0.8			0.8	V
I _{OH} High-level output current			-0.4			-0.4	mA
I _{OL} Low-level output current			16			16	mA
T _A Operating free-air temperature	-55		125	0		70	°C

electrical characteristics over recommended operating free-air temperature range (unless otherwise noted)

PARAMETER	TEST CONDITIONS †	SN5404		SN7404		UNIT	
		MIN	TYP ‡	MAX	MIN		TYP ‡
V _{IK}	V _{CC} = MIN, I _I = -12 mA			-1.5		-1.5	V
V _{OH}	V _{CC} = MIN, V _{IL} = 0.8 V, I _{OH} = -0.4 mA	2.4	3.4	2.4	3.4		V
V _{OL}	V _{CC} = MIN, V _{IH} = 2 V, I _{OL} = 16 mA	0.2	0.4	0.2	0.4		V
I _I	V _{CC} = MAX, V _I = 5.5 V			1		1	mA
I _{IH}	V _{CC} = MAX, V _I = 2.4 V			40		40	µA
I _{IL}	V _{CC} = MAX, V _I = 0.4 V			-1.6		-1.6	mA
I _{OS} §	V _{CC} = MAX	-20		-55		-55	mA
I _{CCH}	V _{CC} = MAX, V _I = 0 V	6	12	6	12		mA
I _{CCL}	V _{CC} = MAX, V _I = 4.5 V	18	33	18	33		mA

† For conditions shown as MIN or MAX, use the appropriate value specified under recommended operating conditions.

‡ All typical values are at V_{CC} = 5 V, T_A = 25°C.

§ Not more than one output should be shorted at a time.

switching characteristics, V_{CC} = 5 V, T_A = 25°C (see note 2)

PARAMETER	FROM (INPUT)	TO (OUTPUT)	TEST CONDITIONS		MIN	TYP	MAX	UNIT
t _{PLH}	A	Y	R _L = 400 Ω,	C _L = 15 pF		12	22	ns
t _{PHL}					8	15	ns	

NOTE 2: See General Information Section for load circuits and voltage waveforms.

TYPES SN74LS04, SN54LS04 HEX INVERTERS

recommended operating conditions

	SN54LS04			SN74LS04			UNIT
	MIN	NOM	MAX	MIN	NOM	MAX	
V _{CC} Supply voltage	4.5	5	5.5	4.75	5	5.25	V
V _{IH} High-level input voltage	2			2			V
V _{IL} Low-level input voltage			0.7			0.8	V
I _{OH} High-level output current			-0.4			-0.4	mA
I _{OL} Low-level output current			4			8	mA
T _A Operating free-air temperature	-55		125	0		70	°C

electrical characteristics over recommended operating free-air temperature range (unless otherwise noted)

PARAMETER	TEST CONDITIONS †	SN54LS04		SN74LS04		UNIT		
		MIN	TYP ‡	MAX	MIN		TYP ‡	MAX
V _{IK}	V _{CC} = MIN, I _I = -18 mA			-1.5		-1.5	V	
V _{OH}	V _{CC} = MIN, V _{IL} = MAX, I _{OH} = -0.4 mA	2.5	3.4	2.7	3.4		V	
V _{OL}	V _{CC} = MIN, V _{IH} = 2 V, I _{OL} = 4 mA		0.25	0.4		0.4	V	
	V _{CC} = MIN, V _{IH} = 2 V, I _{OL} = 8 mA				0.25	0.5		
I _I	V _{CC} = MAX, V _I = 7 V			0.1		0.1	mA	
I _{IH}	V _{CC} = MAX, V _I = 2.7 V			20		20	μA	
I _{IL}	V _{CC} = MAX, V _I = 0.4 V			-0.4		-0.4	mA	
I _{OS} §	V _{CC} = MAX	-20		-100	-20	-100	mA	
I _{CCH}	V _{CC} = MAX, V _I = 0 V		1.2	2.4		1.2	2.4	mA
I _{CCL}	V _{CC} = MAX, V _I = 4.5 V		3.6	6.6		3.6	6.6	mA

† For conditions shown as MIN or MAX, use the appropriate value specified under recommended operating conditions.

‡ All typical values are at V_{CC} = 5 V, T_A = 25°C.

§ Not more than one output should be shorted at a time, and the duration of the short circuit should not exceed one second.

switching characteristics, V_{CC} = 5 V, T_A = 25°C (see note 2)

PARAMETER	FROM (INPUT)	TO (OUTPUT)	TEST CONDITIONS		MIN	TYP	MAX	UNIT
t _{PLH}	A	Y	R _L = 2 kΩ,	C _L = 15 pF		9	15	ns
t _{PHL}						10	15	ns

NOTE 2: See General Information Section for load circuits and voltage waveforms.

TYPES SN74S04, SN54S04
HEX INVERTERS

recommended operating conditions

	SN54S04			SN74S04			UNIT
	MIN	NOM	MAX	MIN	NOM	MAX	
V _{CC} Supply voltage	4.5	5	5.5	4.75	5	5.25	V
V _{IH} High-level input voltage	2			2			V
V _{IL} Low-level input voltage			0.8			0.8	V
I _{OH} High-level output current			-1			-1	mA
I _{OL} Low-level output current			20			20	mA
T _A Operating free-air temperature	-55		125	0		70	°C

electrical characteristics over recommended operating free-air temperature range (unless otherwise noted)

PARAMETER	TEST CONDITIONS †		SN54S04			SN74S04			UNIT
			MIN	TYP ‡	MAX	MIN	TYP ‡	MAX	
V _{IK}	V _{CC} = MIN.	I _I = -18 mA			-1.2			-1.2	V
V _{OH}	V _{CC} = MIN.	V _{IL} = 0.8 V, I _{OH} = -1 mA	2.5	3.4		2.7	3.4		V
V _{OL}	V _{CC} = MIN.	V _{IH} = 2 V, I _{OL} = 20 mA			0.5			0.5	V
I _I	V _{CC} = MAX.	V _I = 5.5 V			1			1	mA
I _{IH}	V _{CC} = MAX.	V _I = 2.7 V			50			50	μA
I _{IL}	V _{CC} = MAX.	V _I = 0.5 V			-2			-2	mA
I _{OS} §	V _{CC} = MAX.		-40		-100	-40		-100	mA
I _{CCH}	V _{CC} = MAX.	V _I = 0 V		15	24		15	24	mA
I _{CCL}	V _{CC} = MAX.	V _I = 4.5 V		30	54		30	54	mA

† For conditions shown as MIN or MAX, use the appropriate value specified under recommended operating conditions.

‡ All typical values are at V_{CC} = 5 V, T_A = 25°C.

§ Not more than one output should be shorted at a time, and the duration of the short circuit should not exceed one second.

switching characteristics, V_{CC} = 5 V, T_A = 25°C (see note 2)

PARAMETER	FROM (INPUT)	TO (OUTPUT)	TEST CONDITIONS		MIN	TYP	MAX	UNIT
t _{PLH}	A	Y	R _L = 280 Ω,	C _L = 15 pF		3	4.5	ns
t _{PHL}						3	5	ns
t _{PLH}			R _L = 280 Ω,	C _L = 50 pF		4.5		ns
t _{PHL}						5		ns

NOTE 2: See General Information Section for load circuits and voltage waveforms.