

A Portable Quad for 2 Meters†

Backpacking, boating or mountaintopping? Invest an afternoon's work and pack this novel directional gain antenna on your next expedition.

By R. J. Decesari,* WA9GDZ/G

Last year, while I was "hilltopping" in the San Diego area with my 2-meter fm transceiver, a band opening occurred in which stations from Los Angeles, Santa Barbara and further points north were copied on simplex frequencies. Establishing solid communications with the built-in quarter-wave whip antenna and 1-watt power of the transceiver (with weakening batteries) was rather difficult, even with the opening. Because of my intense desire to communicate with these DX stations, a need for either a directional gain antenna or a power amplifier was established. Since I didn't particularly desire toting and charging additional batteries for an amplifier, I set this concept aside. I then took a closer look at improving the antenna. This novel portable antenna configuration evolved from many hours of thinking and tinkering in my workshop.

Initial efforts to design a collapsible antenna centered on a conventional four-element Yagi configuration. Several models of the Yagi, whose elements all opened simultaneously, proved to be a nightmare in bell cranks and lever arms. From this attempt, I decided that all the elements should still be attached to a main boom, but the operator would open the elements individually during antenna set-up, thus eliminating the push rods and cranks. The Yagi design, with the elements folding on top of each other to minimize space, was still rather large considering element spacing and other required mechanical appendages and dimensions. At about this time, I happened to spot a big 20-meter quad while driving to work and immediately started to ponder the possibilities of using a quad for the intended portable antenna.

With only two elements, the quad

*3941 Mt. Brundage, San Diego, CA 92111

†A patent is pending on the antenna system described in this article; commercial application of this construction technique is prohibited.

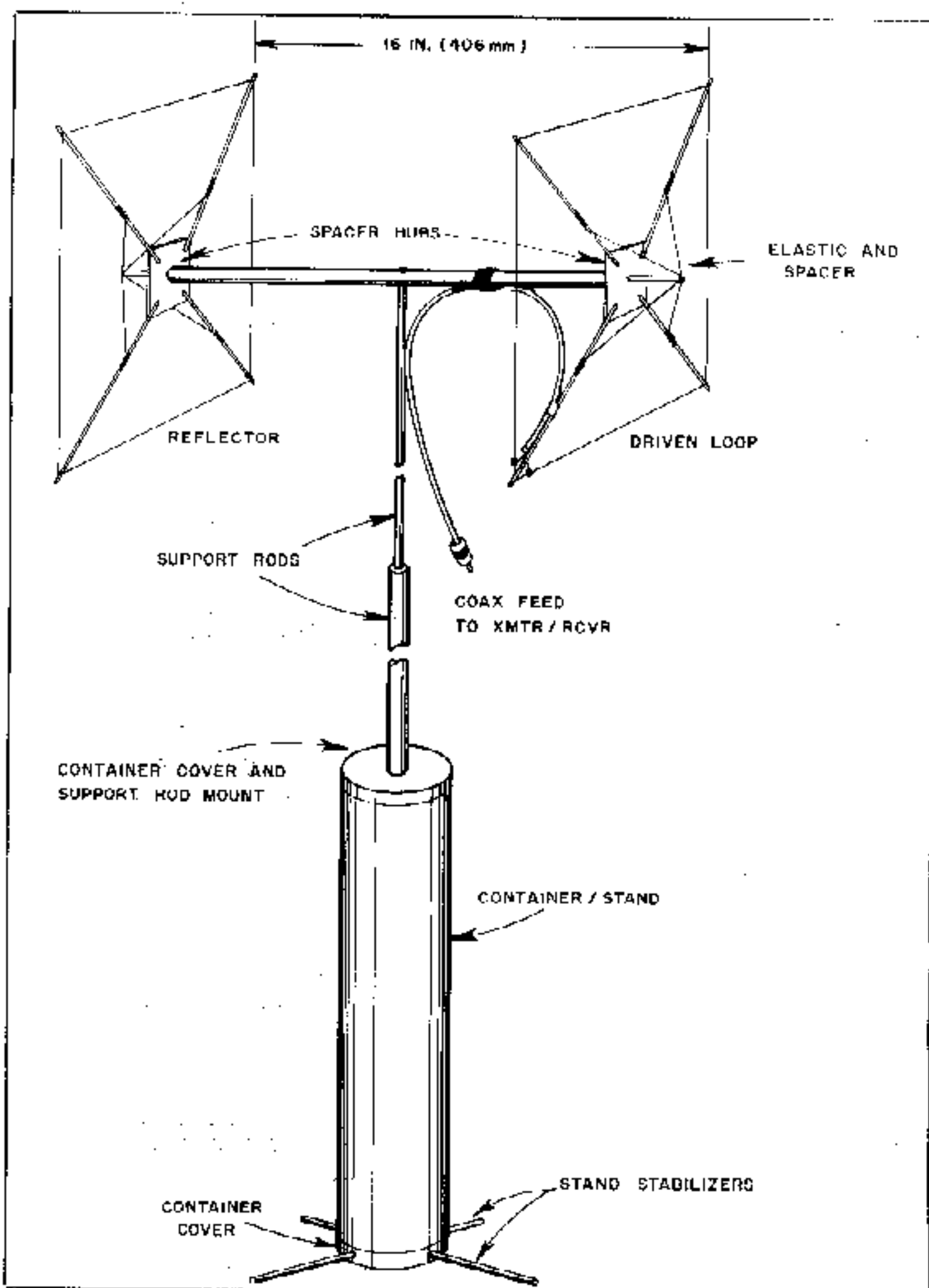

Fig. 1 — The basic portable quad assembly. The author used an element spacing of 16 in. (406 mm) so that the quad spacers would fold neatly between the hubs.

provides an excellent front-to-back ratio, as well as about 6 dB of forward gain. With a two-element quad, the element spacing for optimum reflector performance is between 0.15λ and 0.2λ . That works out to about 12 and 16 inches (305 and 406 mm) at 2 meters. Not a bad overall size for a 2-meter antenna! Now the problem was how to support the square loops. A quick lesson in geometry revealed that if an "X" configuration of spacers were used to support 144-MHz loops, then each leg of the "X" would also be about 16 inches! All that was left to do was design a center hub that would allow the spacers to fold to the longitudinal axis of the boom and the basic problem would be solved. Consequently, the garage workshop was put in to overtime service and the preliminary model of the brainchild was fabricated.

A Quad is Born

Figs. 1 and 2 show the basic portable quad. Both driven and reflector elements fold back on top of each other, resulting in a structure about 17 inches (432 mm) long. The wire loop elements may be held in place around the boom with an elastic band. To support the antenna once it has been erected, the container is used as a stand. To provide more stability, four small removable struts slip into holes in the base of the container. Both the support rods and struts fit inside the container when the antenna is disassembled.

I have used two different methods of keeping the quad spacers erect. Both methods are successful. Fig. 3 shows the quad spacers held open by spring-steel clips. Each clip is fabricated from an ordinary paper binder with a hole drilled in it to allow it to be attached to the quad spacer. The clip is compressed and slid down the quad spacer until it engages the hub. This provides a rigid mechanical support to hold the spacer open when in use as well as allowing it to pivot back for storage in the container. Fig. 4 shows a slightly different method: A mechanical stop is machined into the hub, and elastic bands are used to hold the spacers erect. The bands are attached to an additional strut to hold the spacers open. When not in use, the strut pulls out and sits across the hub, and the spacers can be folded back. Details of each method are shown in Fig. 5.

The clip and hub assembly is possibly easier for the home builder to fabricate, with the exception of drilling the hole in the spring steel. A high-speed-steel or carbide-tipped drill set is required, since the spring steel is an extremely tough and brittle material. Care must be taken when drilling the holes since the clip material will tend to crack. It is recommended that the builder start with a small-diameter drill and proceed to sequentially larger drill diameters until the final diameter is reached. The clip should be expanded and

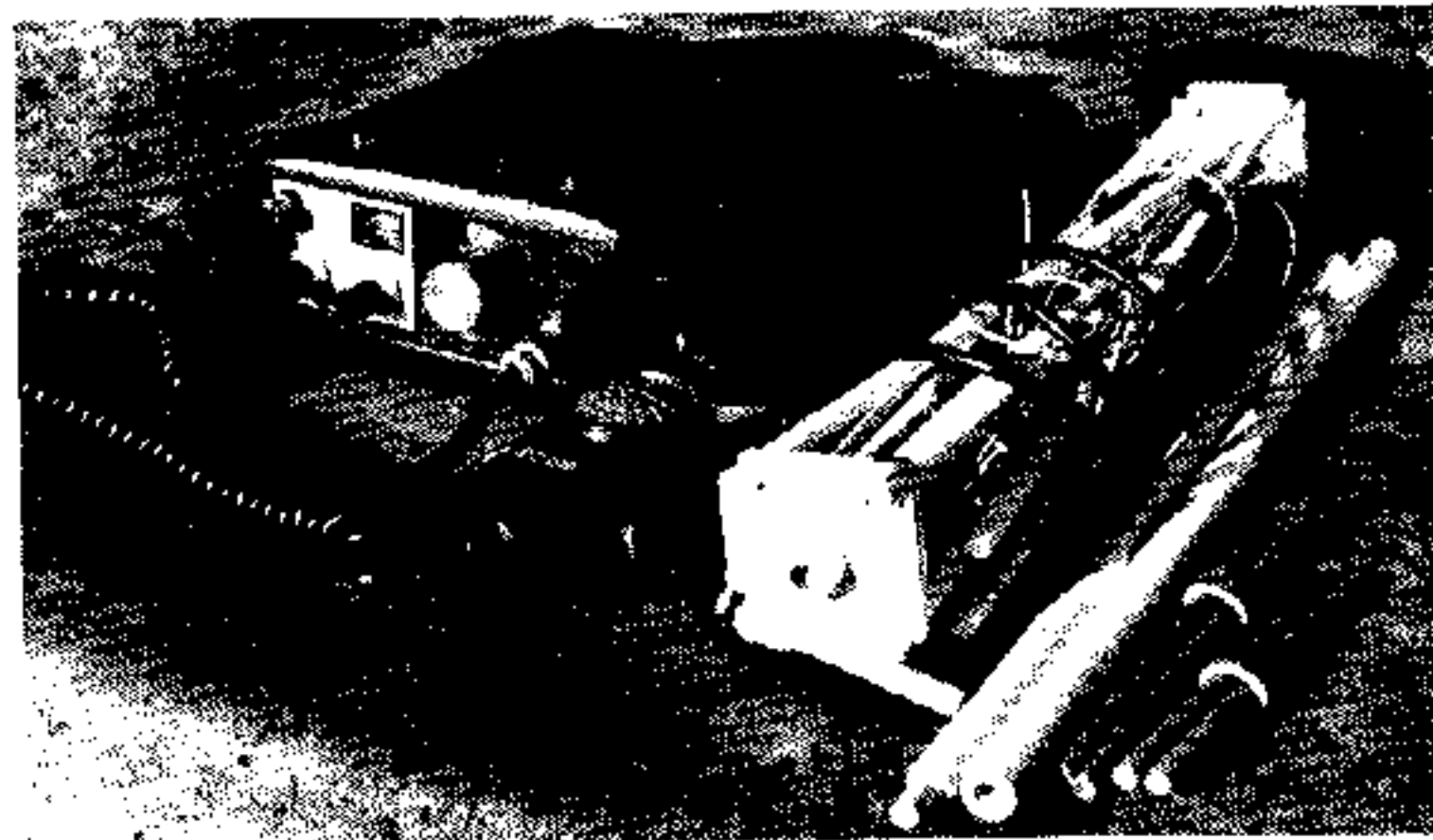

Fig. 2 — The portable quad in stow configuration. Two long dowels are used as support rods. Four smaller dowels are used to stabilize the container.

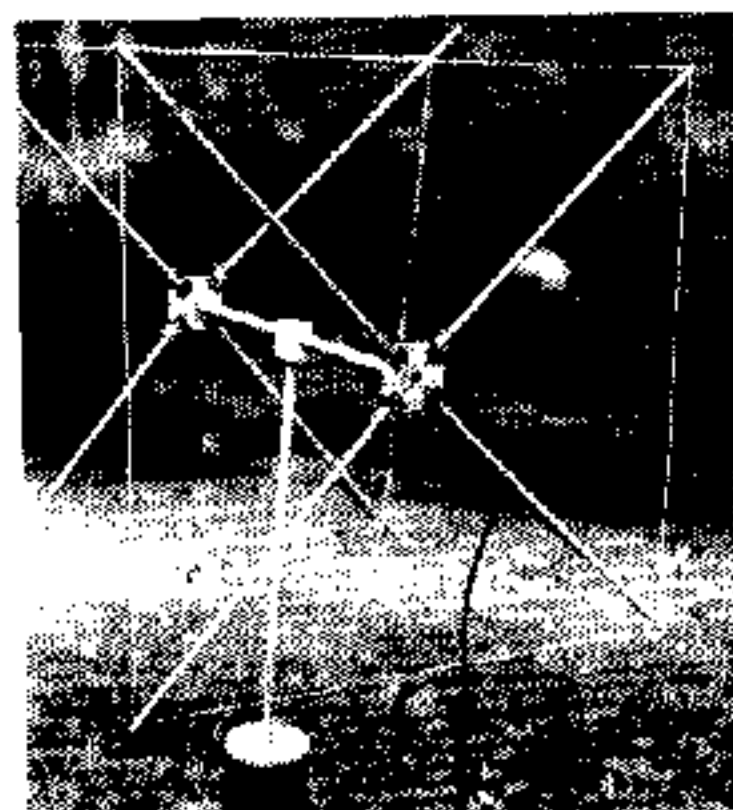

Fig. 3 — Paper-binder spring clips are used in this version of the quad to hold the spacers erect.

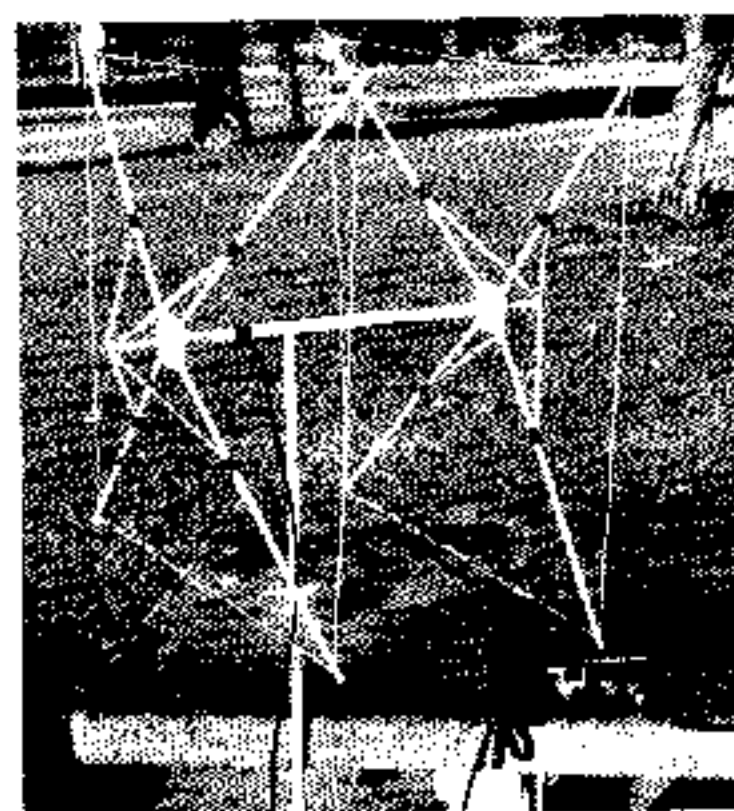

Fig. 4 — This version of the portable quad uses mechanical stops machined into the hub; elastic bands hold the spacers open.

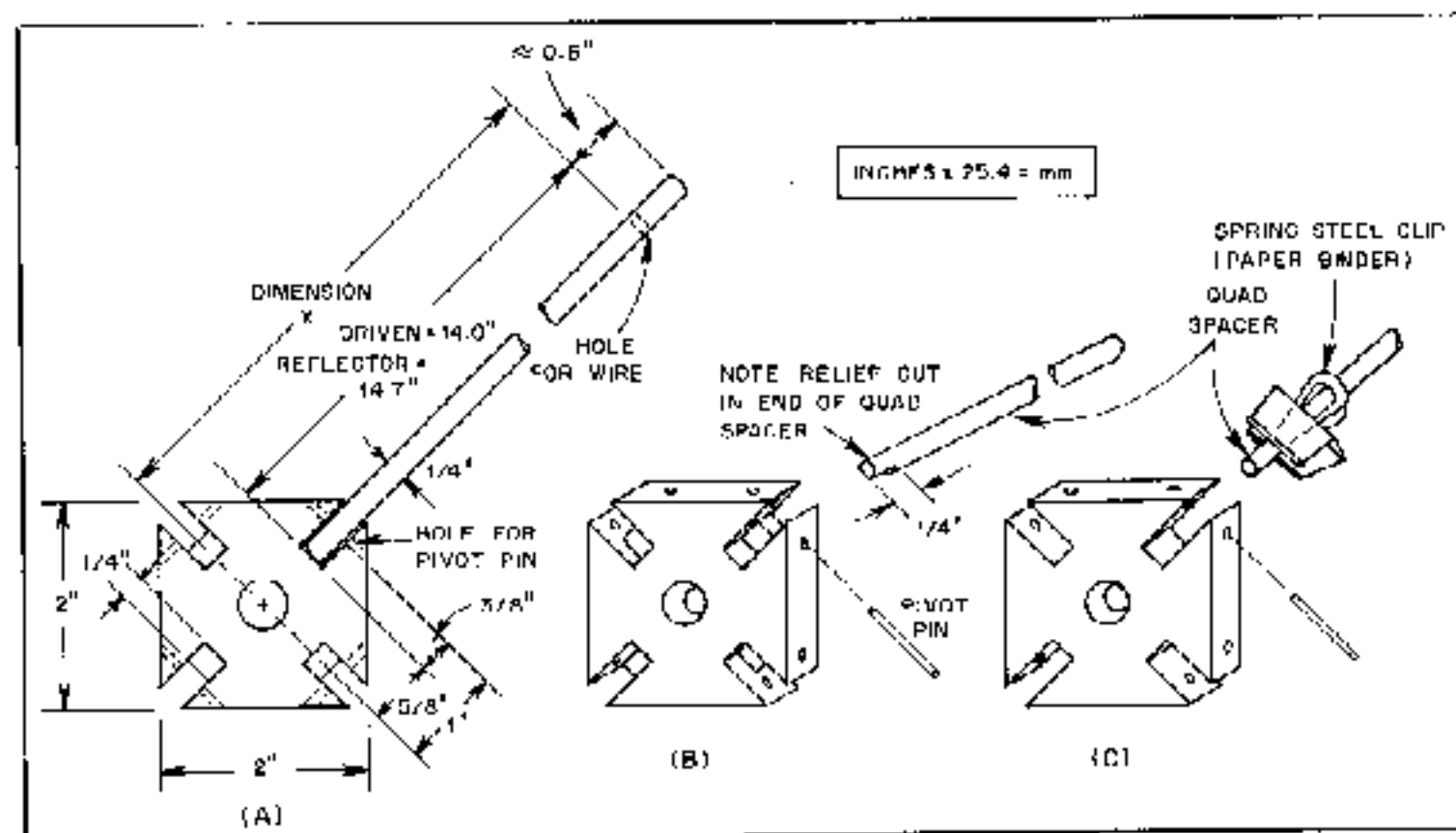

Fig. 5 — A detail of the spacer hub with spacer lengths for the director and reflector is shown at A. The hub is made from 1/4-inch (0.4-mm) plastic or hardwood material. The center-hole diameter can be whatever is necessary to match the diameter of your boom. The version of the hub with mechanical stops and elastic bands is shown at B. At C is the spacer hub version using spring clips.

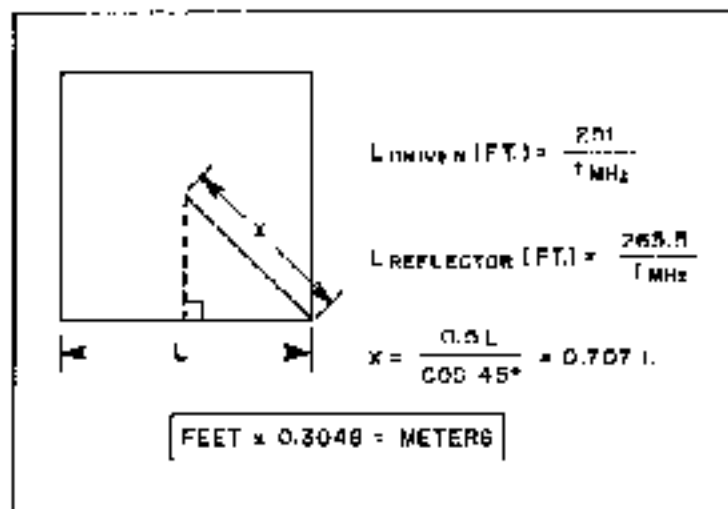

Fig. 6 — Quad loop dimensions. Dimension X is the distance from the center of the hub to the hole drilled in each spacer for the loop wire. At 146 MHz, dimension X for the driven element is 1.216 feet (14.6 inches), and dimension X for the reflector is 1.276 feet (15.3 inches).

fitted over a 1/4-inch (6.4-mm) piece of wood to be used as a drilling back. Use of a light oil is recommended to keep the drill tip cool.

Building Materials

The portable quad antenna may be fabricated from any one of several plastic or wood materials. The most inexpensive method is to use wood doweling, available at most hardware stores. Wood is inexpensive and easily worked with hand tools; 1/4-inch (6.4-mm) doweling may be used for the quad spacers, and 3/8- or 1/2-inch (9.5- or 12.7-mm) doweling may be used for the boom and support elements. A hardwood is recommended for the hub assembly, since a softwood may tend to crack along its grain if the hub is impacted or dropped. Plastics will also work well, but the cost will rise sharply if the material is purchased from a supplier. Plexiglas is an excellent candidate for the hub. Using a router and hand tools, I manufactured a set of Plexiglas hubs with no difficulty. Fiberglass or phenolic rods are also excellent for the quad elements and support.

The loops were made with no. 18 AWG insulated stranded copper wire, although enameled wire may also be used. If no insulation is used on the wire and wood doweling is used for the spacers, a coat of spar varnish in and around the spacer hole through which the wire runs is recommended. The loop wire terminates at one element by attaching to heavy-gauge copper-wire posts inserted into tightly fitting holes in the element. For the driven element, two posts are used to allow the RG-58/U feed-line braid and center conductor to be attached. A single post is used on the reflector to complete the loop circuitry.

The first model of this antenna had a tuning stub attached to the reflector loop. This allowed a certain degree of reflector tuning to maximize its performance. However, I discovered a computer maximization of quad loop and spacing dimen-

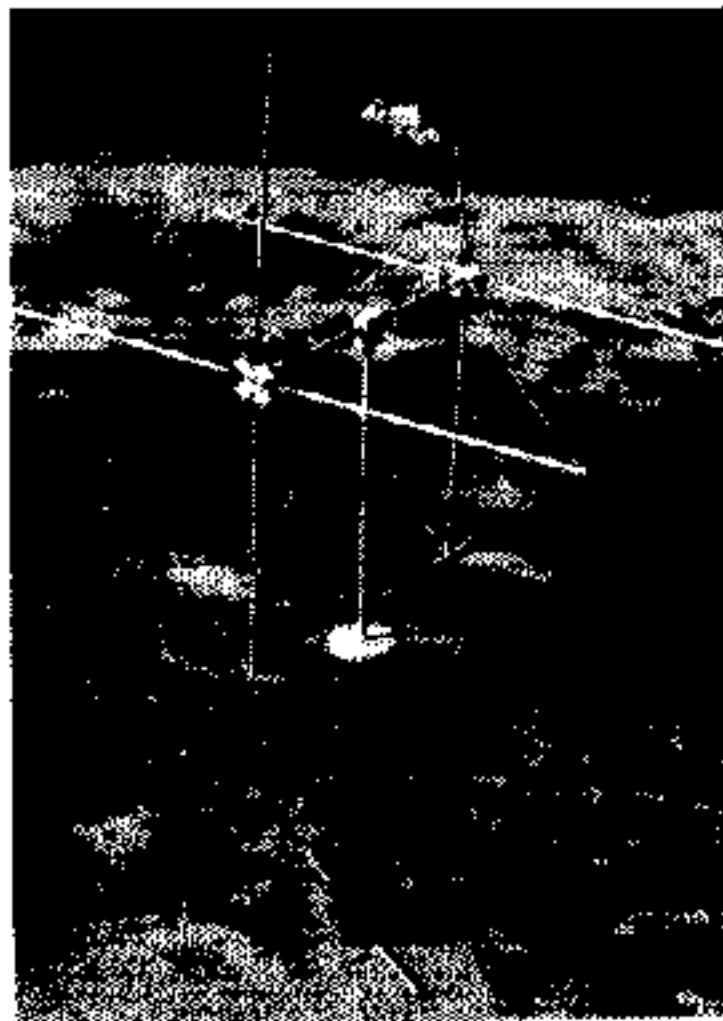

Fig. 7 — A vertically polarized portable quad. The feed point is at the extreme left of the photograph.

sions.¹ This data was used in my subsequent 2-meter quad designs, and has simplified the antenna by eliminating the need for a reflector tuning stub. Fig. 6 shows quad dimensions derived from this data. The quads described in this article have been designed for 146 MHz, but the basic loop size equations will allow the builder to construct a model to any desired frequency in the 2-meter band to maximize results.

The storage container was made from a heavy cardboard tube originally used to store roll paper. Any rigid cylindrical housing of the proper dimensions may be used. Two wood end pieces were fabricated to cap the cardboard cylinder. The bottom end piece is cemented in place and has four holes drilled at 90° angles around the circumference. These holes hold 4-inch (102-mm) struts, which provide additional support when the antenna is erected. The top end piece is snug fitting and removable. It is of sufficient thickness (about 5/8 inch or 16 mm) to provide sufficient support for the antenna-supporting elements. A mounting hole for the supporting elements is drilled in the center of the top end piece. This hole is drilled only about three-quarters of the way through the end piece and should provide a snug fit for the antenna support. One or more antenna support elements may be used, depending on the height the builder wishes to have. Keep in mind, however, that the structure will be more prone to blow over,

¹Optimum gain element spacing found for the quad antenna," *World Radio News*, March 1978.



The author with the fully erected portable quad antenna. The bottom stand is also used as a storage container.

the higher above the ground it gets! Doweling and snug-fitting holes are used to mate the support elements and the antenna boom.

Polarization and Performance

The antennas shown in Figs. 1 through 4 all have 45° diagonal polarization. This is a compromise between vertical and horizontal polarization that allows both fm and ssb/cw (which is usually horizontally polarized) to be worked on 2 meters. Fig. 7 shows another version of the antenna, built for vertical polarization. Although analytical antenna-pattern and gain tests have not been conducted, the portable quad displays an excellent front-to-back ratio as well as gain. The antenna has been used in the field with very satisfying results. The best example of the performance of the antenna was demonstrated by comparison to a 5/8-wave whip antenna. In this demonstration, the 5/8-wave whip was placed on a table top inside the ham shack and excited with 15 watts. From a location in San Diego, the 5/8-wave whip was unable to trigger any of the Los Angeles repeaters about 150 miles to the north. With the portable quad sitting on the same table, full-quieting access was gained to the Los Angeles repeaters.

This antenna design provides a compact package for a directional-gain antenna ideally suited for portable operation. Furthermore, it can be built from readily available and inexpensive materials. I would like to thank my father-in-law for his encouragement and my wife Sue for her patience and indulgence.