

# TL497AC, TL497AI, TL497AY SWITCHING VOLTAGE REGULATORS

SLVS009C – JUNE 1976 – REVISED AUGUST 1995

- High Efficiency . . . 60% or Greater
- Output Current . . . 500 mA
- Input Current Limit Protection
- TTL-Compatible Inhibit
- Adjustable Output Voltage
- Input Regulation . . . 0.2% Typ
- Output Regulation . . . 0.4% Typ
- Soft Start-Up Capability

TL497AC, TL497AI . . . D, N, OR PW PACKAGE  
(TOP VIEW)

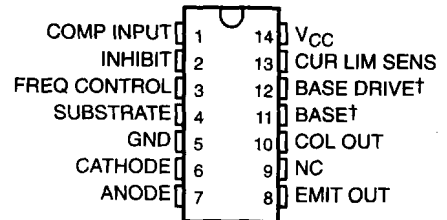

NC – No internal connection

† BASE (11) and BASE DRIVE (12) are used for device testing only. They are not normally used in circuit applications of the device.

## description

The TL497AC and TL497AI incorporate on a single monolithic chip all the active functions required in the construction of switching voltage regulators. They can also be used as the control element to drive external components for high-power-output applications. The TL497AC and TL497AI were designed for ease of use in step-up, step-down, or voltage inversion applications requiring high efficiency.

The TL497AC and TL497AI are fixed-on-time variable-frequency switching-voltage-regulator control circuits. The switch-on time is programmed by a single external capacitor connected between FREQ CONTROL and GND. This capacitor,  $C_T$ , is charged by an internal constant-current generator to a predetermined threshold. The charging current and the threshold vary proportionally with  $V_{CC}$ . Thus, the switch-on time remains constant over the specified range of input voltage (4.5 V to 12 V). Typical on times for various values of  $C_T$  are as follows:

TIMING CAPACITOR, $C_T$ (pF)	200	250	350	400	500	750	1000	1500	2000
ON TIME ( $\mu$ s)	19	22	26	32	44	56	80	120	180

The output voltage is controlled by an external resistor ladder network ( $R_1$  and  $R_2$  in Figures 1, 2, and 3) that provides a feedback voltage to the comparator input. This feedback voltage is compared to the reference voltage of 1.2 V (relative to SUBSTRATE) by the high-gain comparator. When the output voltage decays below the value required to maintain 1.2 V at the comparator input, the comparator enables the oscillator circuit, which charges and discharges  $C_T$  as described above. The internal pass transistor is driven on during the charging of  $C_T$ . The internal transistor may be used directly for switching currents up to 500 mA. Its collector and emitter are uncommitted, and it is current driven to allow operation from the positive supply voltage or ground. An internal Schottky diode matched to the current characteristics of the internal transistor is also available for blocking or commutating purposes. The TL497AC and TL497AI also have on-chip current-limit circuitry that senses the peak currents in the switching regulator and protects the inductor against saturation and the pass transistor against overstress. The current limit is adjustable and is programmed by a single sense resistor,  $R_{CL}$ , connected between  $V_{CC}$  and CUR LIM SENS. The current-limit circuitry is activated when 0.7 V is developed across  $R_{CL}$ . External gating is provided by the INHIBIT input. When the INHIBIT input is high, the output is turned off.

## AVAILABLE OPTIONS

$T_A$	PACKAGED DEVICES			CHIP FORM (Y)
	SURFACE MOUNT (D)	PLASTIC DIP (N)	SHRINK SMALL OUTLINE (PW)	
0°C to 70°C	TL497ACD	TL497ACN	TL497ACPW	TL497AY
-40°C to 85°C	TL497AID	TL497AIN	—	—

PRODUCTION DATA information is current as of publication date. Products conform to specifications per the terms of Texas Instruments standard warranty. Production processing does not necessarily include testing of all parameters.

 **TEXAS  
INSTRUMENTS**

POST OFFICE BOX 655303 • DALLAS, TEXAS 75265

Copyright © 1995, Texas Instruments Incorporated

# TL497AC, TL497AI, TL497AY SWITCHING VOLTAGE REGULATORS

SLVS009C – JUNE 1976 – REVISED AUGUST 1995

## description (continued)

Simplicity of design is a primary feature of the TL497AC and TL497AI. With only six external components (three resistors, two capacitors, and one inductor), the TL497AC and TL497AI operates in numerous voltage conversion applications (step-up, step-down, invert) with as much as 85% of the source power delivered to the load. The TL497AC and TL497AI replace the TL497 in all applications.

The TL497AC is characterized for operation from 0°C to 70°C, and the TL497AI is characterized for operation from -40°C to 85°C.

## functional block diagram

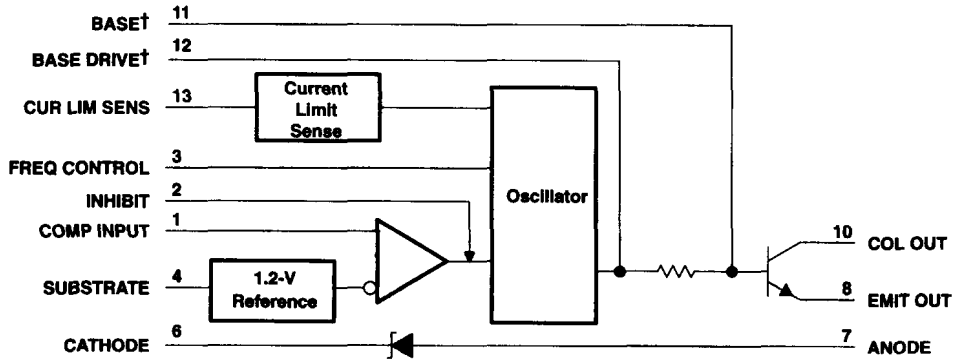

# TL497AC, TL497AI, TL497AY SWITCHING VOLTAGE REGULATORS

SLVS009C - JUNE 1976 - REVISED AUGUST 1995

## TL497AY chip information

This chip, when properly assembled, displays characteristics similar to the TL497AC. Thermal compression or ultrasonic bonding may be used on the doped aluminum bonding pads. The chips may be mounted with conductive epoxy or a gold-silicon preform.

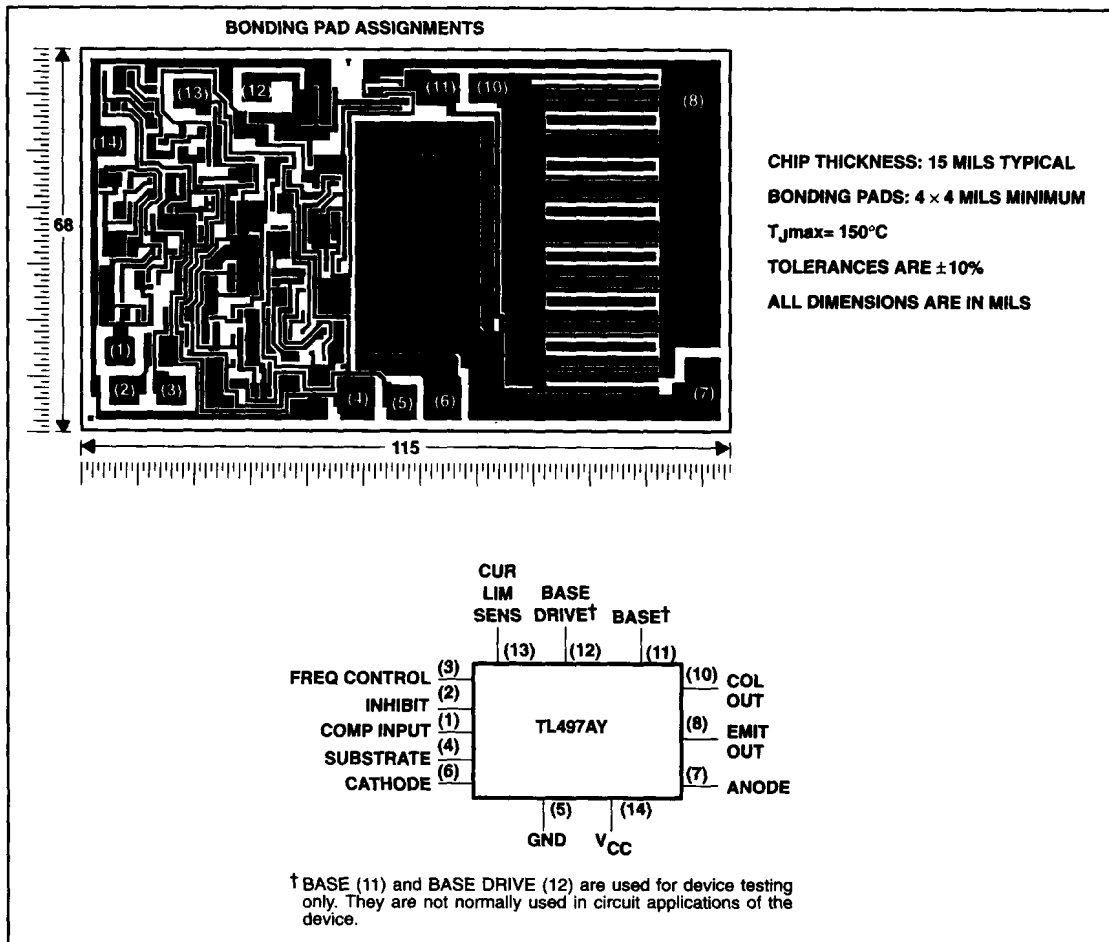

POST OFFICE BOX 655303 • DALLAS, TEXAS 75265

# TL497AC, TL497AI, TL497AY SWITCHING VOLTAGE REGULATORS

SLVS009C – JUNE 1976 – REVISED AUGUST 1995

## absolute maximum ratings over operating free-air temperature range (unless otherwise noted)†

Supply voltage, $V_{CC}$ (see Note 1)	15 V
Output voltage, $V_O$	35 V
Input voltage, $V_I$ (COMP INPUT)	5 V
Input voltage, $V_I$ (INHIBIT)	5 V
Diode reverse voltage	35 V
Power switch current	750 mA
Diode forward current	750 mA
Continuous total power dissipation	See Dissipation Rating Table
Operating free-air temperature range, $T_A$ : TL497AC	0°C to 70°C
TL497AI	-40°C to 85°C
Storage temperature range, $T_{stg}$	-65°C to 150°C
Lead temperature 1,6 mm (1/16 inch) from case for 60 seconds	260°C

† Stresses beyond those listed under "absolute maximum ratings" may cause permanent damage to the device. These are stress ratings only, and functional operation of the device at these or any other conditions beyond those indicated under "recommended operating conditions" is not implied. Exposure to absolute-maximum-rated conditions for extended periods may affect device reliability.

NOTE 1: All voltage values except diode voltages are with respect to network ground terminal.

DISSIPATION RATING TABLE

PACKAGE	$T_A \leq 25^\circ\text{C}$ POWER RATING	DERATING FACTOR	DERATE ABOVE $T_A$	$T_A = 70^\circ\text{C}$ POWER RATING	$T_A = 85^\circ\text{C}$ POWER RATING
D	950 mW	7.6 mW/°C	25°C	608 mW	494 mW
N	1000 mW	9.2 mW/°C	41°C	733 mW	595 mW
PW	700 mW	5.6 mW/°C	25°C	448 mW	—

## recommended operating conditions

		MIN	MAX	UNIT
Supply voltage, $V_{CC}$		4.5	12	V
High-level input voltage, $V_{IH}$ , INHIBIT		2.5		V
Low-level input voltage, $V_{IL}$ , INHIBIT			0.8	V
Output voltage	Step-up configuration (see Figure 1)	$V_I + 2$	30	V
	Step-down configuration (see Figure 2)	$V_{ref}$	$V_I - 1$	
	Inverting regulator (see Figure 3)	$-V_{ref}$	-25	
Power switch current			500	mA
Diode forward current			500	mA
Operating free-air temperature, $T_A$			0	°C
		TL497AC	70	
			-40	
			85	



POST OFFICE BOX 655303 • DALLAS, TEXAS 75285

# TL497AC, TL497AI, TL497AY SWITCHING VOLTAGE REGULATORS

SLVS009C – JUNE 1976 – REVISED AUGUST 1995

**electrical characteristics over recommended operating conditions,  $V_{CC} = 6\text{ V}$  (unless otherwise noted)**

PARAMETER	TEST CONDITIONS	$T_A$ †	TL497AC			TL497AI			UNIT
			MIN	TYP‡	MAX	MIN	TYP‡	MAX	
High-level input current, INHIBIT	$V_I(I) = 5\text{ V}$	Full range		0.8	1.5		0.8	1.5	mA
Low-level input current, INHIBIT	$V_I(I) = 0\text{ V}$	Full range		5	10		5	20	$\mu\text{A}$
Comparator reference voltage	$V_I = 4.5\text{ V to }6\text{ V}$	Full range	1.08	1.2	1.32	1.14	1.2	1.26	V
Comparator input bias current	$V_I = 6\text{ V}$	Full range		40	100		40	100	$\mu\text{A}$
Switch on-state voltage	$V_I = 4.5\text{ V}$	$I_O = 100\text{ mA}$	25°C	0.13	0.2	0.13	0.2		V
		$I_O = 500\text{ mA}$	Full range		0.85		1		
Switch off-state current	$V_I = 4.5\text{ V}, V_O = 30\text{ V}$	25°C		10	50	10	50		$\mu\text{A}$
		Full range			200		500		
Sense voltage, CUR LIM SENS	$V_I = 6\text{ V}$	25°C	0.45		1	0.45		1	V
Diode forward voltage	$I_O = 10\text{ mA}$	Full range		0.75	0.85	0.75	0.95		V
		Full range		0.9	1	0.9	1.1		
		Full range		1.33	1.55	1.33	1.75		
Diode reverse voltage	$I_O = 500\text{ }\mu\text{A}$	Full range				30			V
	$I_O = 200\text{ }\mu\text{A}$	Full range	30						
On-state supply current		25°C		11	14	11	14		mA
		Full range			15		16		
Off-state supply current		25°C		6	9	6	9		mA
		Full range			10		11		

† Full range for the TL497AC is 0°C to 70°C and full range for the TL497AI is -40°C to 85°C.

‡ All typical values are at  $T_A = 25^\circ\text{C}$ .

**electrical characteristics over recommended operating conditions,  $V_{CC} = 6\text{ V}$ ,  $T_A = 25^\circ\text{C}$  (unless otherwise noted)**

PARAMETER	TEST CONDITIONS	TL497AY			UNIT
		MIN	TYP	MAX	
High-level input current, INHIBIT	$V_I(I) = 5\text{ V}$		0.8		mA
Low-level input current, INHIBIT	$V_I(I) = 0\text{ V}$		5		$\mu\text{A}$
Comparator reference voltage	$V_I = 4.5\text{ V to }6\text{ V}$		1.2		V
Comparator input bias current	$V_I = 6\text{ V}$		40		$\mu\text{A}$
Switch on-state voltage	$V_I = 4.5\text{ V}, I_O = 100\text{ mA}$		0.13		V
Switch off-state current	$V_I = 4.5\text{ V}, V_O = 30\text{ V}$		10		$\mu\text{A}$
Diode forward voltage	$I_O = 10\text{ mA}$		0.75		V
	$I_O = 100\text{ mA}$		0.9		
	$I_O = 500\text{ mA}$		1.33		
On-state supply current			11		mA
Off-state supply current			6		mA



POST OFFICE BOX 655303 • DALLAS, TEXAS 75265

# TL497AC, TL497AI, TL497AY SWITCHING VOLTAGE REGULATORS

SLVS009C – JUNE 1976 – REVISED AUGUST 1995

## APPLICATION INFORMATION

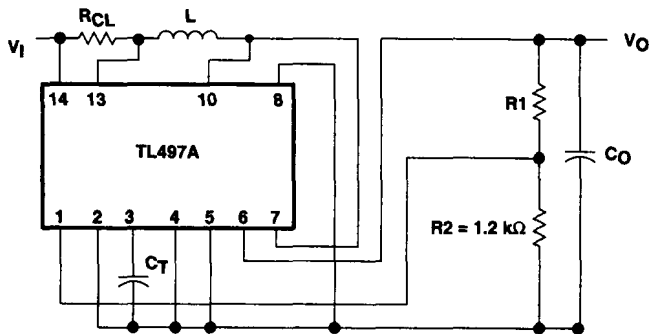

**BASIC CONFIGURATION**  
(Peak Switching Current =  $I_{(PK)} < 500$  mA)

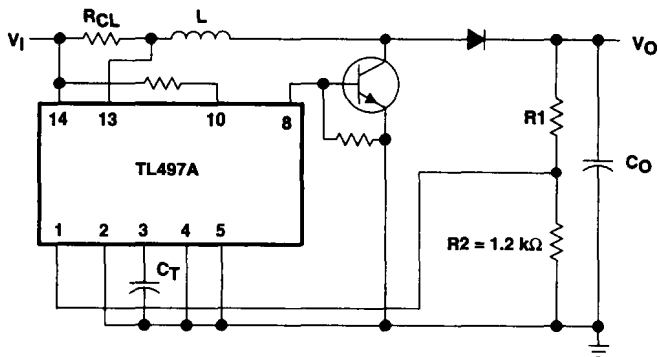

**EXTENDED POWER CONFIGURATION**  
(using external transistor)

### DESIGN EQUATIONS

- $I_{(PK)} = 2 I_O \max \left[ \frac{V_O}{V_I} \right]$

- $L (\mu H) = \frac{V_I}{I_{(PK)}} t_{on} (\mu s)$

Choose L (50 to 500  $\mu H$ ), calculate  $t_{on}$  (25 to 150  $\mu s$ )

- $C_T (pF) \approx 12 t_{on} (\mu s)$

- $R1 = (V_O - 1.2) k\Omega$

- $R_{CL} = \frac{0.5 V}{I_{(PK)}}$

- $C_O (\mu F) \approx t_{on} (\mu s) \frac{\left[ \frac{V_I}{V_O} I_{(PK)} + I_O \right]}{V_{ripple (PK)}}$

**Figure 1. Positive Regulator, Step-Up Configurations**

APPLICATION INFORMATION

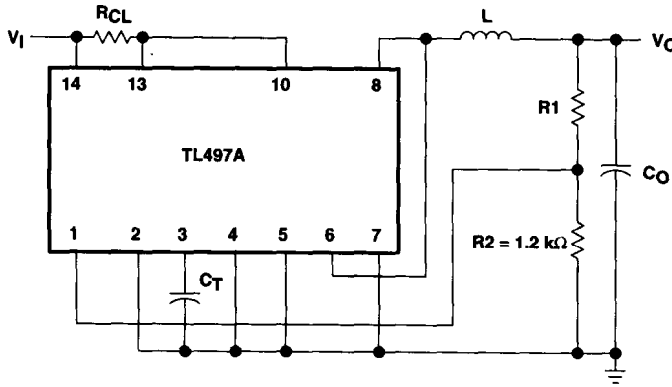

**BASIC CONFIGURATION**  
(Peak Switching Current =  $I_{(PK)} < 500 \text{ mA}$ )

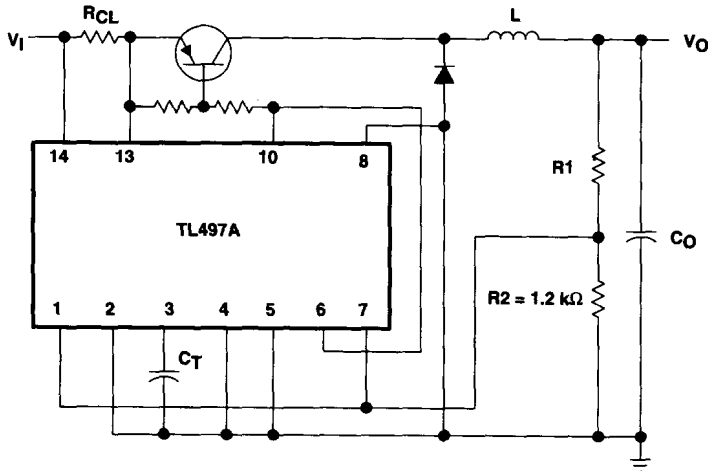

**EXTENDED POWER CONFIGURATION**  
(using external transistor)

DESIGN EQUATIONS

- $I_{(PK)} = 2 I_O \text{ max}$
- $L (\mu\text{H}) = \frac{V_I - V_O}{I_{(PK)}} t_{on}(\mu\text{s})$
- Choose L (50 to 500  $\mu\text{H}$ ), calculate  $t_{on}$  (10 to 150  $\mu\text{s}$ )
- $C_T(\text{pF}) \approx 12 t_{on}(\mu\text{s})$
- $R_1 = (V_O - 1.2) \text{ k}\Omega$
- $R_{CL} = \frac{0.5 \text{ V}}{I_{(PK)}}$
- $C_O (\mu\text{F}) \approx t_{on}(\mu\text{s}) \left[ \frac{V_I - V_O}{V_O} I_{(PK)} + I_O \right] / V_{\text{ripple (PK)}}$

Figure 2. Positive Regulator, Step-Down Configurations

# TL497AC, TL497AI, TL497AY SWITCHING VOLTAGE REGULATORS

SLVS009C - JUNE 1976 - REVISED AUGUST 1995

## APPLICATION INFORMATION

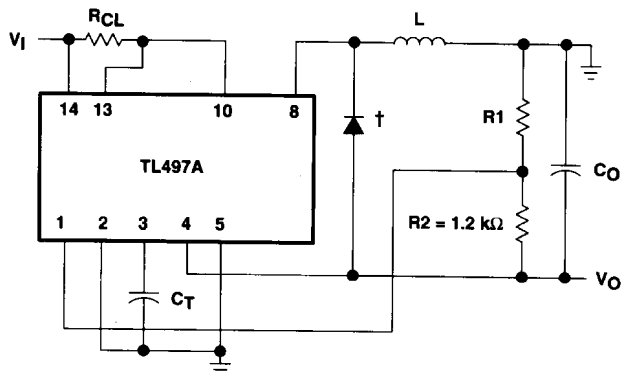

**BASIC CONFIGURATION**  
(Peak Switching Current =  $I_{(PK)} < 500$  mA)

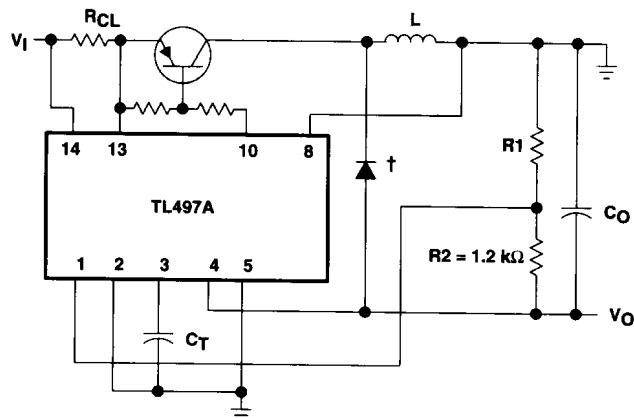

**EXTENDED POWER CONFIGURATION**  
(using external transistor)

† Use external catch-diode, e.g., 1N4001, when building an inverting supply with the TL497A.

**Figure 3. Inverting Applications**

### DESIGN EQUATIONS

$$I_{(PK)} = 2 I_O \max \left[ 1 + \frac{|V_O|}{V_I} \right]$$

$$L (\mu\text{H}) = \frac{V_I}{I_{(PK)}} t_{on}(\mu\text{s})$$

Choose L (50 to 500  $\mu\text{H}$ ), calculate  $t_{on}$  (10 to 150  $\mu\text{s}$ )

$$C_T(\text{pF}) \approx 12 t_{on}(\mu\text{s})$$

$$R_1 = (|V_O| - 1.2) \text{ k}\Omega$$

$$R_{CL} = \frac{0.5 \text{ V}}{I_{(PK)}}$$

$$C_O (\mu\text{F}) \approx t_{on}(\mu\text{s}) \frac{\left[ \frac{V_I}{|V_O|} I_{(PK)} + I_O \right]}{V_{\text{ripple}} (PK)}$$



APPLICATION INFORMATION

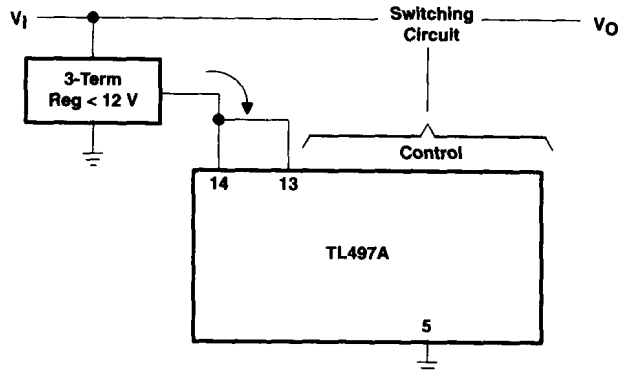

EXTENDED INPUT CONFIGURATION WITHOUT CURRENT LIMIT

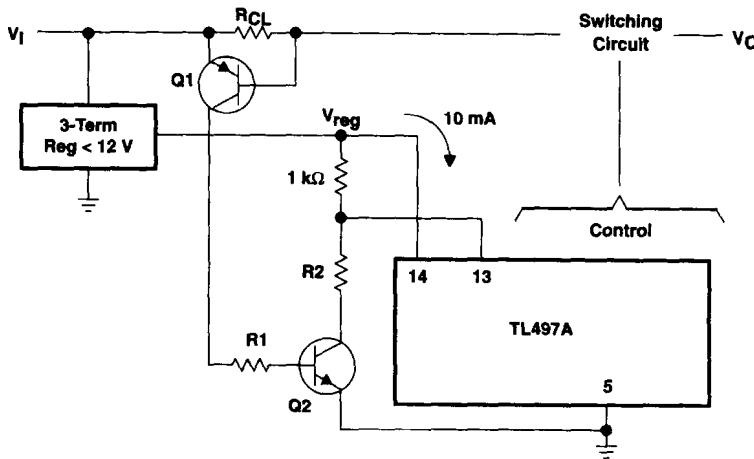

DESIGN EQUATIONS

- $R_{CL} = \frac{V_{BE}(Q1)}{I_{limit} (PK)}$
- $R1 = \frac{V_I}{I_B(Q2)}$
- $R2 = (V_{reg} - 1) 10 \text{ k}\Omega$

CURRENT LIMIT FOR EXTENDED INPUT CONFIGURATION

Figure 4. Extended Input Voltage Range ( $V_I > 12 \text{ V}$ )