

LM1871 RC Encoder/Transmitter

General Description

The LM1871 is a complete six-channel digital proportional encoder and RF transmitter intended for use as a low power, non-voice, unlicensed communication device at carrier frequencies of 27 MHz or 49 MHz with a field strength of 10,000 $\mu\text{V}/\text{meter}$ at 3 meters. In addition to radio controlled hobby, toy and industrial applications, the encoder section can provide a serial input of six words for hard wired, infrared or fiber optic communication links. Channel add logic is provided to control the number of encoded channels from three to six, allowing increased design flexibility. When used with the LM1872 RC receiver/decoder, a low cost RF linked encoder and decoder system provides two analog and two ON/OFF decoded channels.

Features

- Low current 9V battery operation
- On-chip RF oscillator/transmitter
- One timing capacitor for six proportional channels
- Programmable number of channels
- Regulated RF output power
- External modulator bandwidth control
- On-chip 4.6V regulator
- Up to 80 MHz carrier frequency operation

Block and Connection Diagram

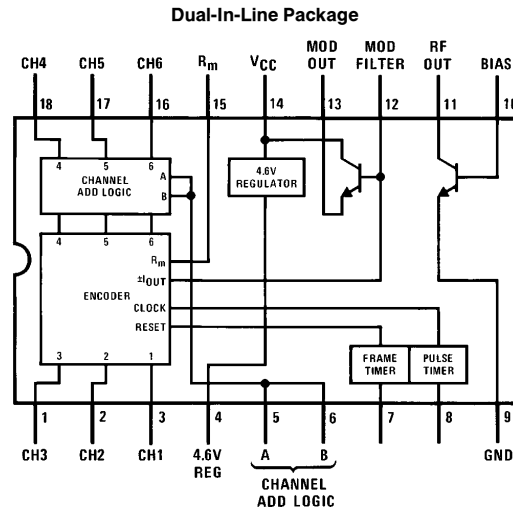

TL/H/7911-1

Order Number LM1871N
See NS Package Number N18A

Absolute Maximum Ratings

If Military/Aerospace specified devices are required, please contact the National Semiconductor Sales Office/Distributors for availability and specifications.

Supply Voltage	16V
DC Current Out of Pin 4	10 mA
DC Current Out of Pin 13	25 mA

Package Dissipation (Note 1)	1600 mW
Pin 4 Externally Forced	6V
Operating Temperature Range	-25°C to +85°C
Storage Temperature Range	-65°C to +150°C
Lead Temperature (Soldering, 10 sec.)	260°C

Electrical Characteristics $T_A = 25^\circ\text{C}$, $V_{CC} = +9\text{V}$, see Test Circuit and Waveforms

Symbol	Parameter	Conditions	Min	Typ	Max	Units
Encoder Section, Close S1, S2, S4 Open S3						
V14	Supply Voltage		4.5	9	15	V
I ₁₄	Supply Current	Encoder Only	10	14	22	mA
V4	Reference Voltage		4.1	4.8	5.4	V
t _f	Frame Time	$t_f = R_F C_F + 0.63 R_{MOD} C_T$	8	9.5	10.5	ms
t _m	Mod Time	$t_m = 0.63 R_{MOD} C_T$	0.4	0.5	0.6	ms
t _{ch}	Channel Time	$t_{ch} = 0.63 R_{CH} C_T$	0.4	0.5	0.6	ms
t _s	Sync Time, T _x Channels 1-6	Close S1, Close S2		3.5		ms
t _s	Sync Time, T _x Channels 1-5	Open S1, Close S2		4.5		ms
t _s	Sync Time, T _x Channels 1-4	Close S1, Open S2		5.5		ms
t _s	Sync Time, T _x Channels 1-3	Open S1, Open S2		6.5		ms
Δt _n	Supply Rejection, t _m + t _{CH}	ΔV _{CC} = 6V to 12V		0.1		%/V
ΔV13	Encoder Output Swing			3.8		V _{p-p}
ΔV12	Mod Filter Output Swing			3.8		V _{p-p}
I ₁₂	Mod Filter Source/Sink Current			0.5		± mA
R _{IN(8)}	Pulse Timer Input Resistance			27		MΩ
I _{TH(7)}	Frame Timer Threshold Current			0.1		μA
I _{LEAK(15)}	Mod Timer Leakage Current	Pin 15 to 0V		0.01	1	μA
V _{SAT(15)}	Mod Timer Saturation Voltage	I ₁₅ = 2 mA, (V4-V15)		120	240	mV
I _{LEAK(CH)}	Channel Timer Leakage Current	Pins 1, 2, 3, 16, 17, 18 to 4.6V		0.06	1	μA
V _{SAT(CH)}	Channel Timer Saturation Voltage	I _{CH} = 2 mA		120	240	mV
RF Oscillator Section, Collector Pin 11, Base Pin 10, Emitter Pin 9 Open S4						
V _{OUT}	RF Output Level	Use RF Voltmeter Close S3		400		mV _{RMS}
I ₁₄	Supply Current	Open S3, S4		30		mA
f _t	Transistor	V _{CE} = +5V, I _C = 10 mA		520		MHz
V _{SAT(11)}	Transistor Saturation Voltage	f _o = 49 MHz		800		mV
H _{FE}	Transistor BC Beta	I _C = 10 mA	75	150	350	
LV _{CEO}		I _C = 10 μA	16	20		V

Note 1: For operation in ambient temperatures above 25°C, the device must be derated based on a 150°C maximum junction temperature and a package thermal resistance of 75°C/W junction to ambient.

Test Circuit and Switching Time Waveforms

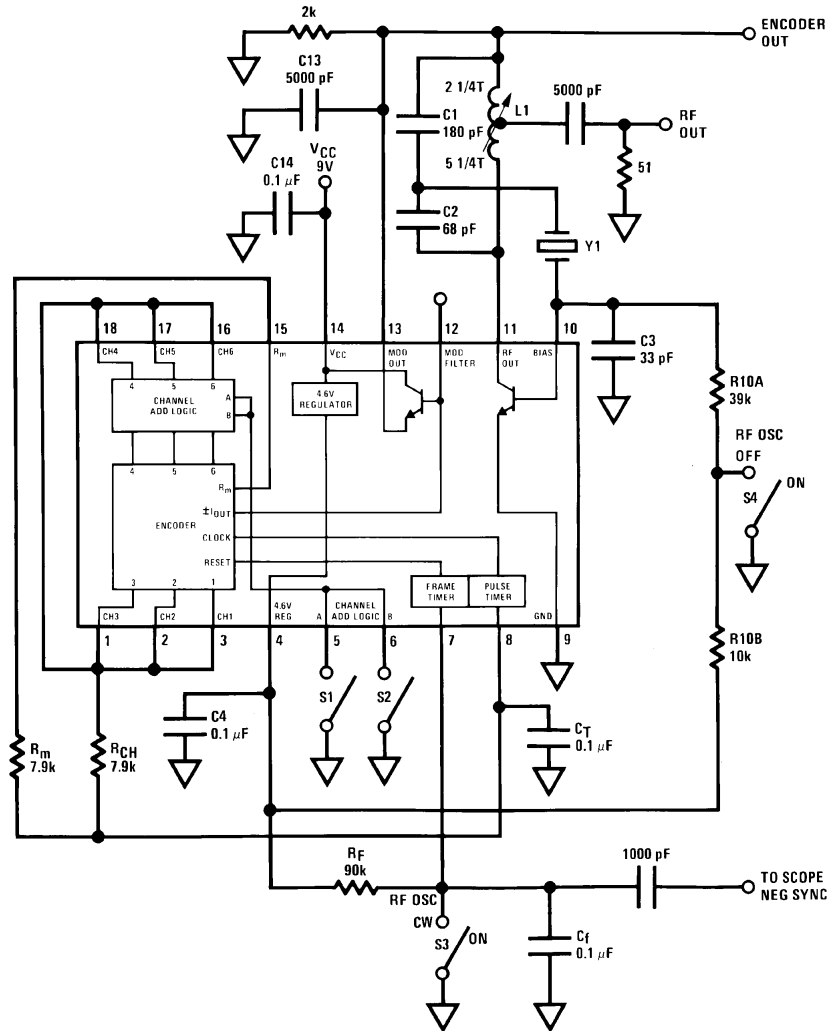

Note: Test circuit has been configured for evaluation by oscilloscope. Use 1% timing components. R_m , R_{CH} , R_F , C_T

TL/H/7911-2

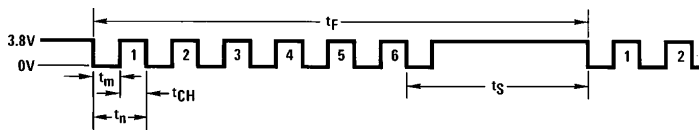

L1: Toko E523LN-7210019 type MC117 7½ turns with tap 2¼ turns from top
 Y1: 49.86 MHz crystal 3rd overtone
 Encoder output (pin 13) close S1, S2, S4, 0.5 ms/div sweep

TL/H/7911-3

Typical Performance Characteristics

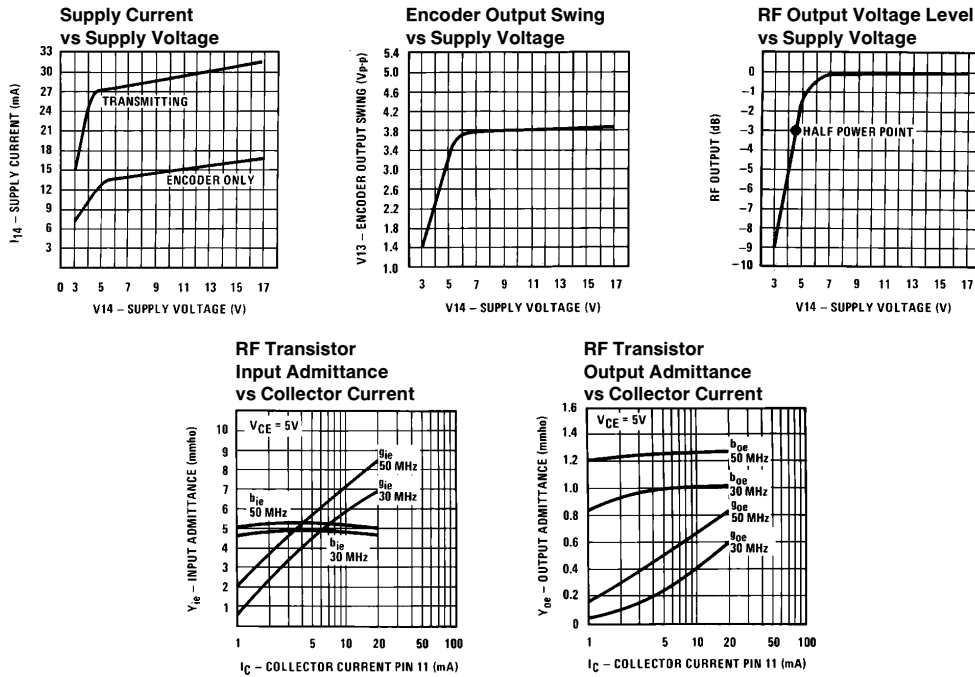

TL/H/7911-4

Applications Information

The LM1871 has been designed to encode and transmit 27 MHz or 49 MHz carriers for remote radio control (RC) of up to six independent analog functions. The encoder section converts a variable potentiometer setting to a variable pulse width. The variable pulse widths, each preceded by a fixed modulation pulse, are added together sequentially and then followed by a synchronization pulse. Figure 1 shows the digital proportional control format and how the channel pulse widths, sync time and frame time are defined.

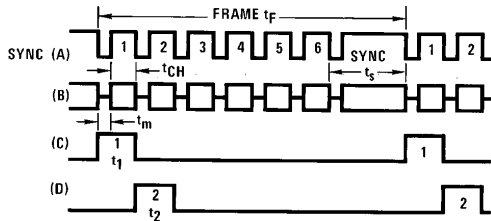

TL/H/7911-5

FIGURE 1. (A) Encoder Output (Pin 13)
(B) Transmitted RF Carrier Envelope
(C) Typical Receiver Channel 1 Output
(D) Typical Receiver Channel 2 Output

Figure 1 (A) shows the encoder output waveform. The modulation time (t_m) is fixed while the channel time (t_{ch}) is the variable pulse width. In Figure 1 (C, D) the recovered channel pulse (t_n) is the sum of t_m and t_{ch} at a rep rate set by the frame time (t_f). Because the frame time is fixed, the sync time (t_s) will vary inversely to the variable channel times.

After detection by the RC receiver, the channel pulse widths must now be converted back to the required analog functions, which might be a mechanical arm movement, motor speed control or simply an ON/OFF transistor switch. In the case of the mechanical arm movement, commercially available closed loop servo modules can be found in most hobby shops. The input requirements of these servos will determine the transmitted frame time and channel pulse width range. Usually the pulse width for arm at center will be 1.5 ms; for full left, 1.0 ms; and for full right, 2.0 ms, at a rep rate of 20 ms. A motor speed control open loop servo can be designed for the same input pulse widths: 1.0 ms for maximum forward speed, 1.5 ms with some dead band for motor OFF and 2.0 ms for maximum reverse speed. In both servo systems the input pulse width being continuously variable allows full control of arm position, motor speed and direction. The ON/OFF function could also use the same input pulse width range (1 ms ON, 2 ms OFF).

The 1.0 ms to 2.0 ms pulse width range required by most servo modules is a result of transmitted RF spectrum limitations required by the FCC. If the modulation time (t_m) and the channel time were made very short ($\approx 10 \mu s$ each)

Applications Information (Continued)

many sidebands 5 kHz apart would be generated on each side of the center frequency. The amplitude and number of sidebands are determined by the depth and duration of the modulation pulse. FCC regulations require that all sidebands greater than 10 kHz from center frequency be less than $500 \mu\text{V}/\text{meter}$ at three meters. In the example cited above, the 100% modulated carrier spectrum would not be acceptable if the field strength of the carrier was $10,000 \mu\text{V}/\text{meter}$ at three meters. If the modulation and channel times were made much longer ($\approx 10 \text{ ms}$ each) the transmitted spectrum would be acceptable but now the frame time would be longer than desirable for optimum servo designs. When the received channel pulse widths are

between 1.0 ms and 2.0 ms at a frame rate of 20 ms the modulation time should be between $400 \mu\text{s}$ and $600 \mu\text{s}$ to insure an acceptable transmitted RF spectrum.

Figure 2 shows the block diagram and a typical application of the LM1871 utilizing two fully proportional (analog) channels and two uniquely encoded ON/OFF (digital) channels. The LM1872 Receiver/Decoder, a companion IC to the LM1871, has been designed to receive and decode two analog channels and two digital channels. The two digital channel output states are determined by the number of transmitted channels rather than by the width of a channel pulse. Table I shows the digital output format as a function of the number of transmitted channels.

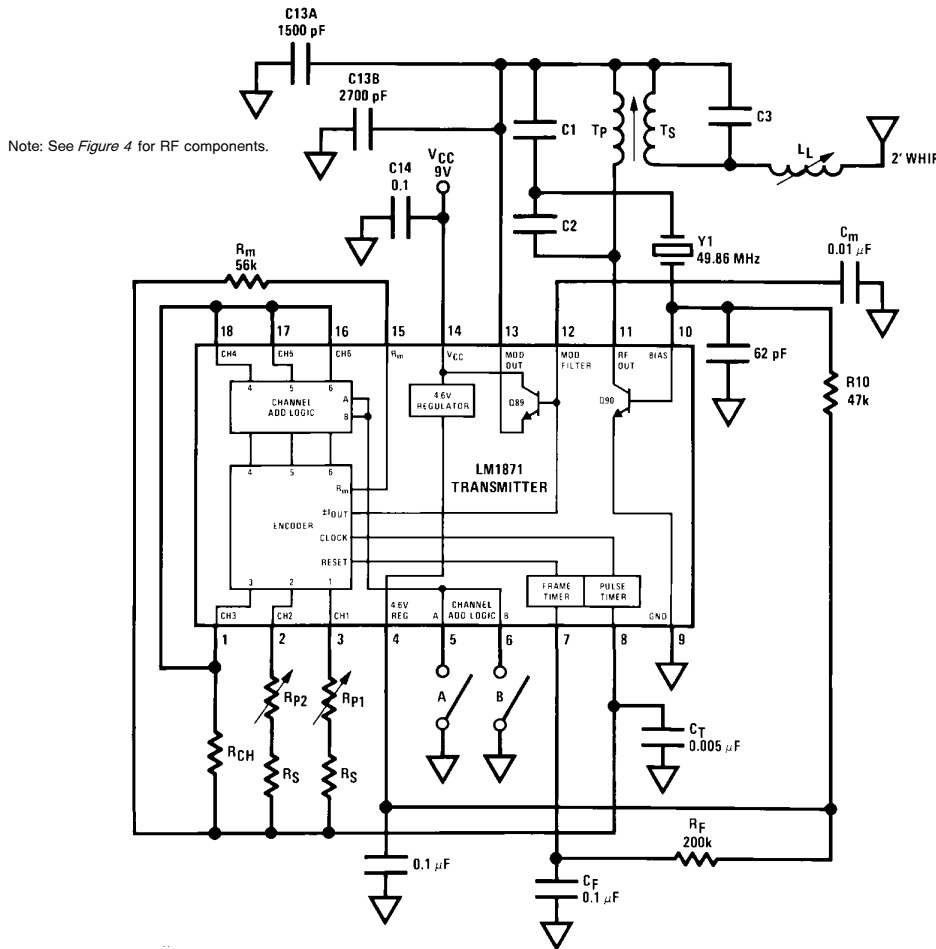

TL/H/7911-6

Applications Information (Continued)

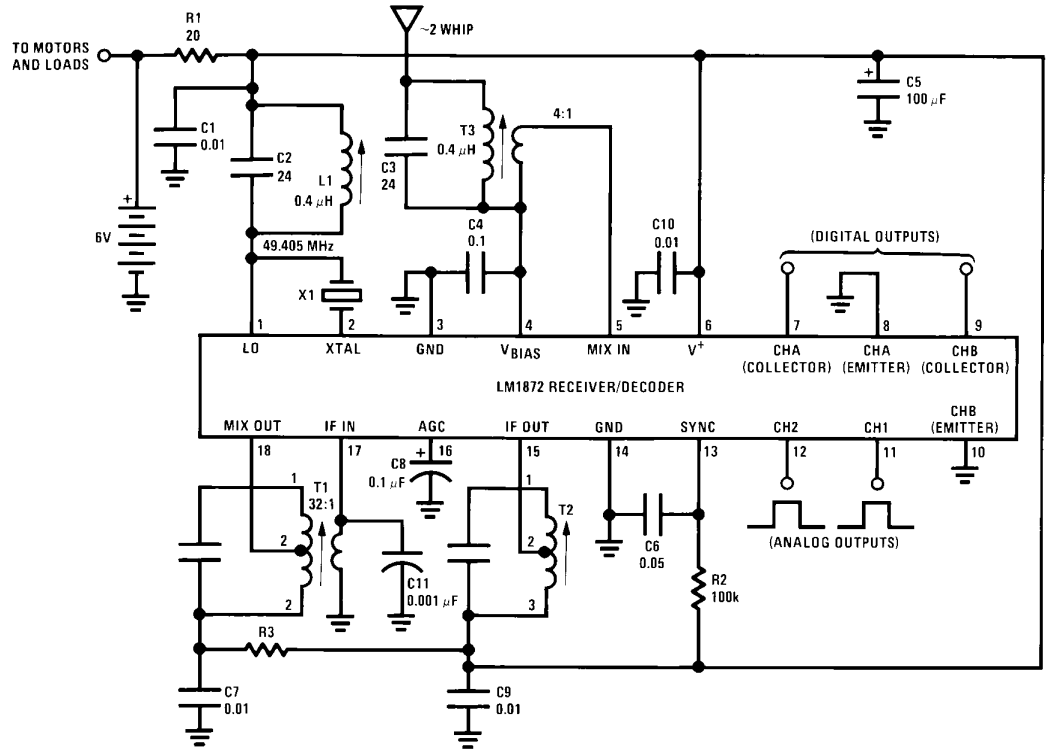

TL/H/7911-7
 T1 = Toko RMC 202313 } Q_O = 110
 T2 = Toko RMC 402503 }
 T3, L1 = Toko KEN 4028DZ

FIGURE 2. Two Channel Analog/Two Channel Digital Transmitter/Receiver Application

Applications Information (Continued)

LM1871 ENCODER TIMING

Figure 3 shows the two timing circuits and waveforms used by the LM1871. The frame timer oscillator consists of a high gain comparator and a saturating NPN transistor switch. When the NPN transistor is turned OFF the timing capacitor (C_F) will charge up to $\frac{2}{3}$ of the V_{REG} voltage. The comparator will then turn ON the NPN transistor, discharging the capacitor back to ground ending the timing cycle. The pulse timing circuit is similar in operation except that the timing capacitor (C_T) is charged and discharged between $\frac{1}{3}$ and $\frac{2}{3}$ of the V_{REG} voltage. The saturating PNP transistor switch pulls up the modulation timing resistor (R_M) which charges C_T to $\frac{2}{3}$ V_{REG} and six independently switched NPN transistors provide the discharge path through the channel timing resistors (R_{CH}). The time constant for both circuits can be found as follows:

$$\frac{-t}{RC} = \ln \frac{V_1}{V_2}$$

when V_1 = Voltage across timing resistor at end of timing cycle.

V_2 = Voltage across timing resistor at beginning of timing cycle.

In the frame timer circuit the NPN transistor is held on for a period determined by the modulation pulse (t_m). This was done to insure that the timing capacitor was fully discharged. The frame (t_f), modulation (t_m) and channel time (t_{ch}) can be calculated as follows:

$$t_f = -\ln \frac{1.534}{4.6V} (R_F C_F) + t_m = 1.1 R_F C_F + t_m$$

$$t_m \text{ or } t_{ch} = -\ln \frac{1.534}{3.06V} (R_M \text{ or } R_{CH}) C_T \\ = 0.69 (R_M \text{ or } R_{CH}) C_T$$

The above calculated time constants will be modified by transistor saturation resistances and comparator switching voltages that are slightly different than the $\frac{1}{3}$ and $\frac{2}{3}$ V_{REG} reference. One time constant should be used for the frame time (t_f) and 0.63 time constant should be used for the modulation (t_m) and channel (t_{ch}) times. Because the switching voltages are a percentage of the V_{REG} voltage the timer accuracy will not be affected by a low battery condition ($V_{CC} < 5.6V$). High and low temperature ($-25^\circ C$ to $+85^\circ C$) operation also has little effect on timer accuracy.

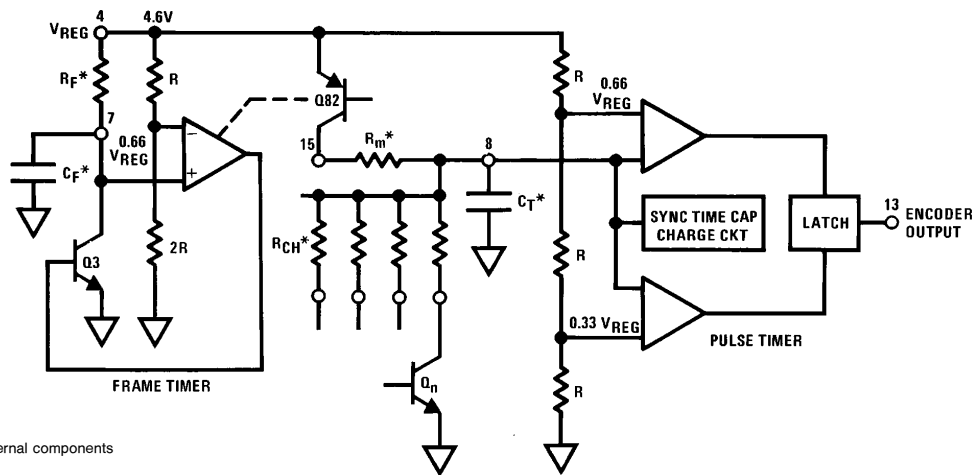

*External components

TL/H/7911-8

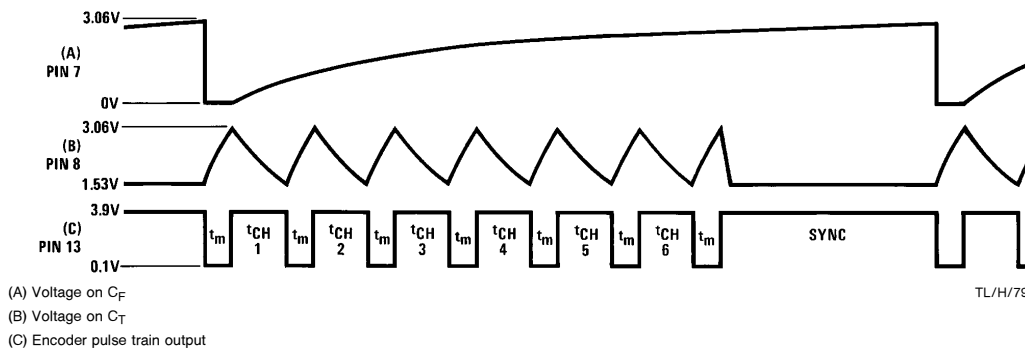

TL/H/7911-9

FIGURE 3. Simplified Encoder Timing Circuits and Waveforms

Applications Information (Continued)

The accuracy and temperature characteristics of the external components will determine the total accuracy of the system. The capacitors should be NPO ceramics or other low-drift types.

As an example the following procedure can be used to determine the external timing components required for Figure 2.

- Given: Frame time (t_f) = 20 ms
 Modulation time (t_m) = 500 μ s
 Recovered pulse width (t_n) range = 1.0 ms to 2.0 ms with trim capability
 Non variable channel pulse width (t_n) = 1.0 ms

1. Frame Timer Components

Choose $C_F = 0.1 \mu\text{F} \pm 10\%$

$$R_F = \frac{t_f - t_m}{C_T} = \frac{20 \text{ ms} - 0.50 \text{ ms}}{0.1 \mu\text{F}} = 195 \text{ k}\Omega \text{ (200 k}\Omega\text{)}$$

2. Modulation Time Components

Choose $C_T = 0.01 \mu\text{F} \pm 10\%$

$$R_M = \frac{t_m}{0.63C_T} = \frac{500 \times 10^{-6}}{(0.63)(1 \times 10^{-8})} = 79.36 \text{ k}\Omega \text{ (82 k}\Omega\text{)}$$

3. Non-Variable Channel (3 through 6) Component

$t_{ch} = t_n - t_m = 1.0 \text{ ms} - 0.50 \text{ ms} = 500 \mu\text{s}$

$$R_{CH} = \frac{t_{ch}}{0.63C_T} = \frac{500 \times 10^{-6}}{(0.63)(1 \times 10^{-8})} = 79.36 \text{ k}\Omega \text{ (82k)}$$

4. Variable Channel 1(t_1) and Channel 2 (t_2) Components

When the R_P wiper arm varies across the full potentiometer range, ($\Delta R = 0\Omega$ to R_P value) R_S is found for 0Ω and minimum t_n pulse width.

$$R_S = \frac{t_n - t_m}{0.63C_T} = \frac{1 \text{ ms} - 0.50 \text{ ms}}{(0.63)(1 \times 10^{-8})} = 79.36 \text{ k}\Omega \text{ (82k)}$$

$R_P(\Delta R)$ is found for maximum t_n pulse width.

$$\begin{aligned} R_P &= \frac{t_n - t_m}{0.63C_T} - R_S \\ &= \frac{2 \text{ ms} - 0.50 \text{ ms}}{(0.63)(1 \times 10^{-8})} - 82 \text{ k}\Omega \\ &= 156 \text{ k}\Omega \end{aligned}$$

The R_P value could have been chosen first and a C_T calculated. Usually the 270° to 320° angle of potentiometer rotation is inconvenient especially if it is desired to spring return the control to center, or if lever type knobs are required. A

500 k Ω potentiometer that has 300° of end to end wiper arm rotation could be used if mechanical stops limit this range.

$$\text{Required angle of rotation} = \frac{(300^\circ)(156 \text{ k}\Omega)}{500 \text{ k}\Omega} = 93.6^\circ$$

In most applications the resistor and capacitor tolerances prevent sufficient system accuracy without mechanical or electrical trimming of the analog channel pulse widths. If a 500k potentiometer is used, two trim methods can be utilized. R_S can also be included as part of the potentiometer resistance.

Potentiometer Body for Mechanical Trim

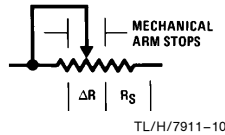

for Electrical Trim

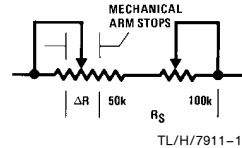

$$\Delta R = 156 \text{ k}\Omega, R_S = 82 \text{ k}\Omega$$

If $t_n = 1.5 \text{ ms} \pm 30\%$ is required:

$$\pm R_{TRIM} = 0.3 \frac{\Delta R}{2} + R_S = 48 \text{ k}\Omega$$

$$\text{Required Body Rotation} = \frac{(300^\circ)(48\text{k})}{500\text{k}} = \pm 28.8^\circ$$

Channel Add Logic

Table I shows the number of transmitted channels as a function of pin 5 and pin 6 conditions. The threshold voltage for both pins is $\approx 0.7\text{V}$. When grounded, the pins are sourcing $\approx 300 \mu\text{A}$ from the internal pull up resistors. External voltages may be applied to these pins but should be below the V_{REG} voltage by at least one volt and not less than the pin 9 ground.

Modulator and Crystal Oscillator/Transmitter Circuit (FIGURE 4)

The modulator and oscillator consist of but two NPN transistors whose operation is quite straightforward. The base of the modulator transistor is driven by a bidirectional current source with the voltage range for the high condition limited by a saturating PNP collector to the pin 4 V_{REG} voltage and

TABLE I. Digital Channel Output Format as a Function of Transmitted Channels

LM1871 Channel Add Logic Pin Conditions		Number of Channels Transmitted	LM1872 Receiver Digital Outputs	
Pin 5 (A)	Pin 6 (B)		A	B
OPEN	OPEN	3	OFF	OFF
GND	OPEN	4	ON	OFF
OPEN	GND	5	OFF	ON
GND	GND	6	ON	ON

Applications Information (Continued)

low condition limited by a saturating NPN collector in series with a diode to ground. A current source of $\pm 500 \mu\text{A}$ was chosen to provide a means for external modulator bandwidth control. When a capacitor is used at this node the transmitted RF carrier is made to slew ON and OFF at a time determined by:

$$\text{Modulation slew time } (t_{ms}) = \frac{(\Delta V_{12})(C_M)}{I_{12}} = \frac{(3.8V)(0.01 \mu\text{F})}{500 \mu\text{A}} = 76 \mu\text{s}$$

when ΔV_{12} = peak to peak voltage swing of pin 12 = 3.8V
 $\pm I_{12}$ = source/sink current from pin 12 = 500 μA
 C_M = capacitance at pin 12 = 0.01 μF

Figure 5 shows the advantage gained by this capacitor especially if adjacent channels are 10 kHz to 15 kHz away from the desired channel.

The crystal oscillator/transmitter is configured to oscillate in a class C mode with the conduction angle being approximately 140° to 160° . Resistor R10 provides the base bias current from the pin 4 V_{REG} voltage. This resistor value has been optimized for most RC applications. When the emitter of the modulation transistor is high ($\approx 3.8V$) the collector and tank coil are pulled up into the active range of the oscillator transistor. RF feedback to the base is via the series mode crystal which determines the oscillator frequency. Because third overtone crystals are used for 27 MHz or 49 MHz applications a tuned collector load must be used to guarantee operation at the correct frequency. Tuning the

LC tank, while having little effect on oscillator frequency, will control the conduction angle and oscillator efficiency. Tuning the LC tank for minimum V_{CC} supply current while observing the carrier envelope on an oscilloscope would be the best alignment method.

For most RC applications the carrier ON to OFF ratio must be as high as possible to ensure precise pulse width detection at the receiver. If we were to look at the base of the oscillator transistor we would see that the crystal is still oscillating during the time that the carrier is OFF (t_m). This is because of the high Q characteristic (10k to 30k) of crystals in this application. We can roughly calculate the number of cycles required for a decay or rise in amplitude for one time constant (63% of final value) by:

$$\text{Number of cycles} = \frac{4Q}{\pi}$$

At 49 MHz this will be 15k cycles or 300 μs for a crystal Q of 30k. At 27 MHz this time will be 560 μs for the same crystal Q. If long carrier OFF times were required the oscillator start up time would as a result also be quite long. The shorter carrier OFF times overcome one problem but do suggest that the crystal be isolated from the antenna circuit. During the carrier OFF time the base of the modulator transistor is held approximately 0.9V above ground such that the emitter still supplies current to the now saturated collector of the oscillator transistor. Both ends of the LC tank circuit now "see" a low impedance to ground. Further isolation is provided by the split tuning capacitor.

Component	27 MHz	49 MHz
T _P	2 Turns	6 Turns
T _S	3 Turns	1 Turn
L ₁	TOKO KXN K4636 B JF	TOKO KEN K4635 BJE
L _L	MILLER # 4611	MILLER # 9330-10
C _A	5.4 pF	6.2 pF
R _A	1.15 Ω	3.78 Ω
C ₁	1000 pF	220 pF
C ₂	680 pF	47 pF
C ₃	20 pF	33 pF
R ₁₀	24k	47k

Toko America
 1250 Feehanville Drive
 Mount Prospect, IL 60056
 (312) 297-0070

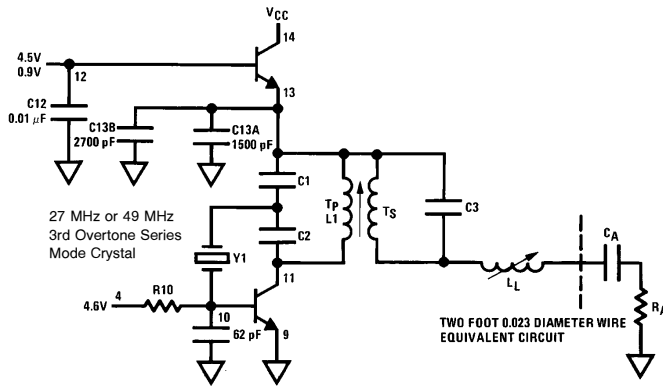

FIGURE 4. 27 MHz and 49 MHz RF Oscillator/Transmitter

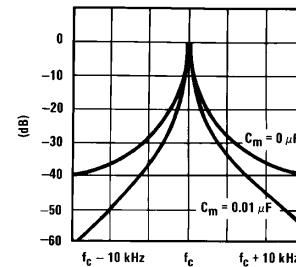

FIGURE 5. Envelope of Transmitted Spectrum for Circuit in Figure 2

Applications Information (Continued)

If the printed circuit board shown in *Figure 6* is to be reproduced, it is recommended that the layout be followed as closely as possible. The positions of pin 13 decoupling capacitors and coil components tend to be critical in regard to undesired harmonic emissions. Short lead ceramic disc capacitors and short decoupled traces are recommended. A number of boards with this configuration have successfully met all requirements of the FCC as perceived only by National Semiconductor. Final approval of any unlicensed transmitter is granted only by the FCC via certified test measurements.

Field Strength Measurements

As noted above the maximum radiated RF energy of an unlicensed transmitter operating in the 27 MHz or 49 MHz frequency band must not be greater than 10k μV per meter at a distance of 3 meters from the transmitting antenna. In addition to the carrier amplitude requirement, all sidebands greater than 10 kHz from the carrier and all other emissions (harmonic or spurious) must be less than 500 μV per meter at a distance of 3 meters.

The term used for electrical field intensity (V/meter at 3 meters) refers to the open circuit voltage induced at the output of a resonant half-wave dipole antenna in a single dimensional one meter field, 3 meters distant from the transmitter under test. When making field intensity measurements, the antenna length must be adjusted for resonance at each frequency of interest and the induced voltage made proportional to the one meter reference length. The induced voltage value must not include losses caused by the inser-

tion of a 1:1 balun transformer (-6 dB) or loading (-6 dB) and mismatch (72Ω to 50Ω , -1.7 dB) of the voltage measuring instrument. We can now relate the induced voltage (V_{IN}) to a measured voltage (V_{MEA}) by:

$$V_{MEA} = \frac{V_{IN} L}{\text{Losses}} \text{ or } V_{IN} = \frac{(V_{MEA}) (\text{Losses})}{L}$$

where: V_{MEA} = Voltage measured by a spectrum analyzer or calibrated receiver.

V_{IN} = Field intensity (volts/meter).

L = Half-wave length of antenna in meters.

Losses = All mismatch, loading and insertion losses. (In this case = 13.7 dB = 4.87)

The length of a half-wave dipole antenna is found by:

$$L = \frac{Ck}{2f} \text{ meters}$$

where: C = Speed of light in a vacuum.

k = A constant related to antenna length to width ratios, end effects and surface effects. Use $k = 0.96$ for practical antenna rods $\frac{5}{16}$ " in diameter.

f = Frequency of interest.

$$\text{Simplified: } L = \frac{144}{f \text{ MHz}} \text{ meters}$$

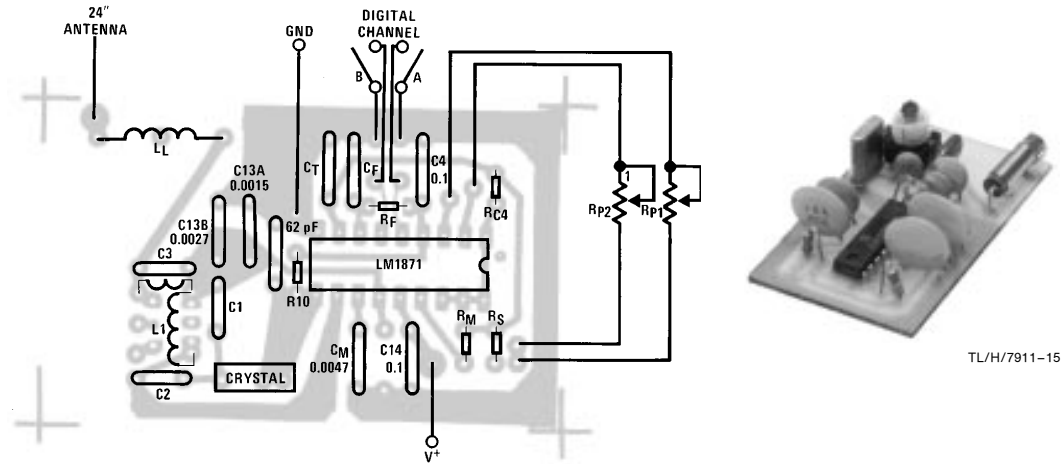

FIGURE 6

TL/H/7911-14

TL/H/7911-15

Applications Information (Continued)

Now that we have a way in interpreting the field strength measurements we must deal with the technique used in making these measurements. Usually all measurements are done outside on a flat area away from trees, buildings, buried pipes or whatever. The test transmitter is placed on a wooden stool or table approximately 3 feet high such that the vertical antenna is in a vertical position. The receiving dipole is adjusted for the frequency of interest and oriented to the same plane as the transmitter and placed 3 meters from the transmitter. The dipole may be mounted on a wooden pole or ladder such that the height of the antenna can easily be changed. The antenna length must always be symmetrical about the center tapped balun transformer. The operator and his test equipment must be "behind" the dipole by some 3 or more feet. If it is desired to have the operator at a much more distant location the transmission line must be characterized for additional losses. A number of measurements should be made at each frequency for different heights and orientations of both the transmitting and receiving antennas. The highest reading should be considered the correct reading. In addition to fundamental, sidebands and harmonic emissions, the frequency spectrum from 25 MHz to 1000 MHz should also be scanned for spurious emissions greater than 50 $\mu\text{V}/\text{meter}$ at 3 meters.

Additional Applications

Figure 2 shows a typical application of the LM1872 Receiver/Decoder. The LM1872 consists of a crystal controlled local oscillator, IF amplifier, AGC, detector, decoder logic and digital channel output drivers. The supply voltage range of 2.5V min to 7V max was chosen to allow battery operation by four "C" or "D" cells.

Figure 7 shows how the LM1871 encoder can be used to frequency shift a 200 kHz carrier that is transmitted over the 110V AC line in a home or office. Figure 8 shows how ON/OFF carrier modulation is also possible. An LM1872 could be used as a receiver/decoder for the Figure 8 transmitter circuit. When using an LM1872 the carrier frequencies should be 50 kHz or greater to insure proper detector operation.

Figure 9 shows the LM1871 configured for six analog channels with a TTL compatible output. The V_{REG} voltage at pin 4 has been shorted to V_{CC} . This allows a $V_{\text{CC(MIN)}}$ of 3V and $V_{\text{CC(MAX)}}$ of 6V. The encoder output could be used for

a fiber optic transmitter/receiver link, infra-red, tone keying or transducer carrier modulation. If the encoder output is hard wired to the Figure 10 serial input we can recover the six analog channels. From Figure 11 we see that the data input will appear during the sync time which is always longer than any channel time (t_n). Inverter X1 will discharge C1 each time the input goes high. During the longer sync time C1 will charge up to the $\frac{1}{2} V_{\text{CC}}$ threshold of X2 and via X3 provide the data input. The R and C components are calculated by:

$$t_{\text{data delay}} = 0.565 R_1 C_1$$

If large values of C1 ($>0.01 \mu\text{F}$) are required the diode D1 should be replaced by a PNP transistor with the base on X1 output, emitter to X2 input and collector to ground.

In applications requiring ON/OFF decoding of a channel pulse width the circuit shown below could be used.

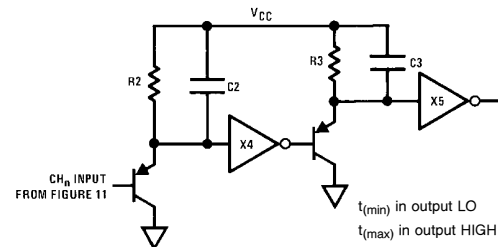

TL/H/7911-16

If the recovered channel pulse width is short ($t_{(\text{min})}$) R2 and C2 are selected such that the input to inverter X4 does not rise to the $\frac{1}{2} V_{\text{CC}}$ threshold. The output of X4 will be high and the output of X5 will be low. A longer input pulse ($t_{(\text{max})}$) will allow the output of X4 to go low pulling the input of X5 low. R3 and C3 are selected such that the input to X5 will not rise past the $\frac{1}{2} V_{\text{CC}}$ threshold during the remainder of the frame time. The R and C values are found by:

$$\text{Given: } t_{(\text{min})} = 1.0 \text{ ms, } C_2 = 0.01 \mu\text{F}$$

$$t_{(\text{max})} = 2.0 \text{ ms, } C_3 = 0.1 \mu\text{F}$$

$$t_{\text{frame}} = 20 \text{ ms}$$

$$0.565 R_2 C_2 = t_{(\text{min})} + \frac{t_{(\text{max})} - t_{(\text{min})}}{2} = 1.5 \text{ ms}$$

$$R_2 = \frac{1.5 \text{ ms}}{0.565 C_2} = 270 \text{ k}\Omega$$

$$R_3 = \frac{t_{\text{frame}}}{0.565 C_3} = 360 \text{ k}\Omega$$

Additional Applications (Continued)

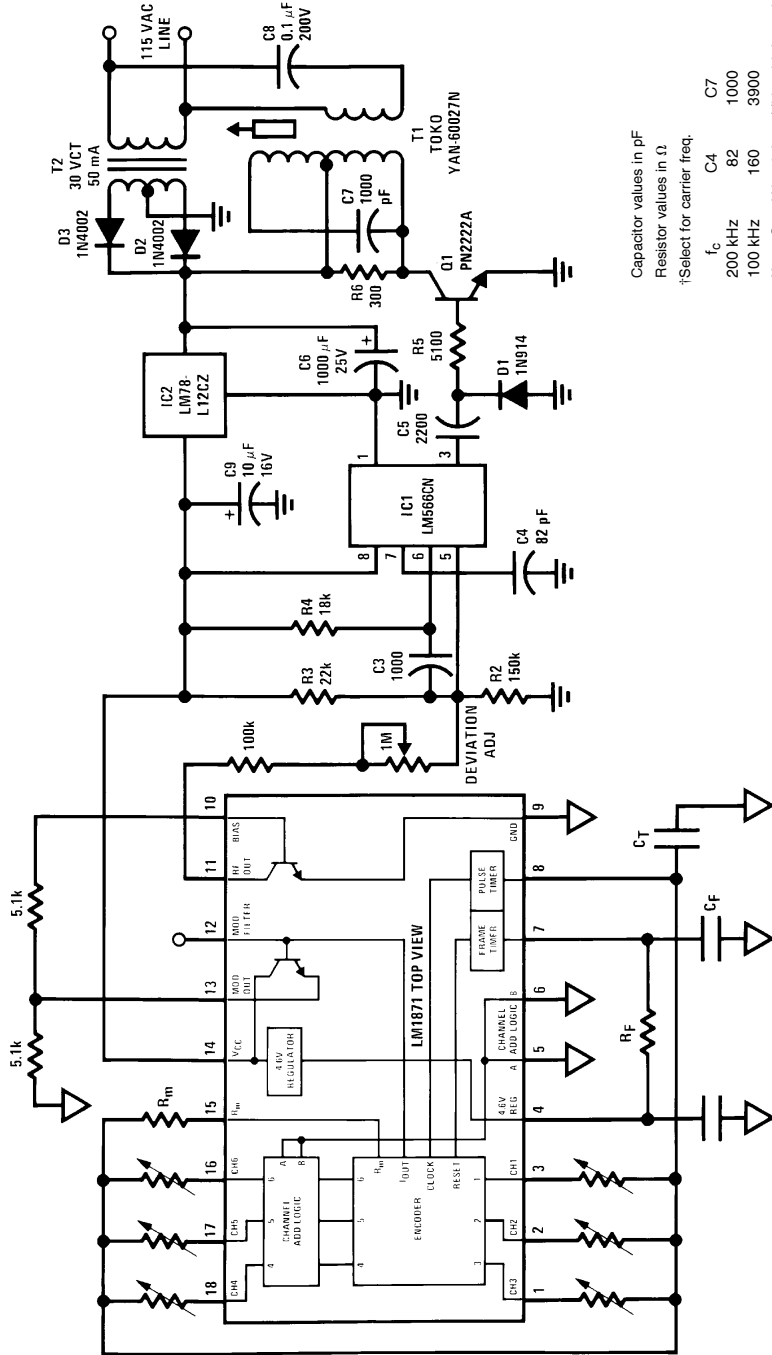

Capacitor values in pF
 Resistor values in Ω
 †Select for carrier freq.

f_c	C4	C7
200 kHz	82	1000
100 kHz	160	3900

Note: See AN-146 for additional information.
 TL/H/7911-17

FIGURE 7. LM1871, LM566 200 kHz Line Carrier Transmitter with FSK Carrier Modulation

Additional Applications (Continued)

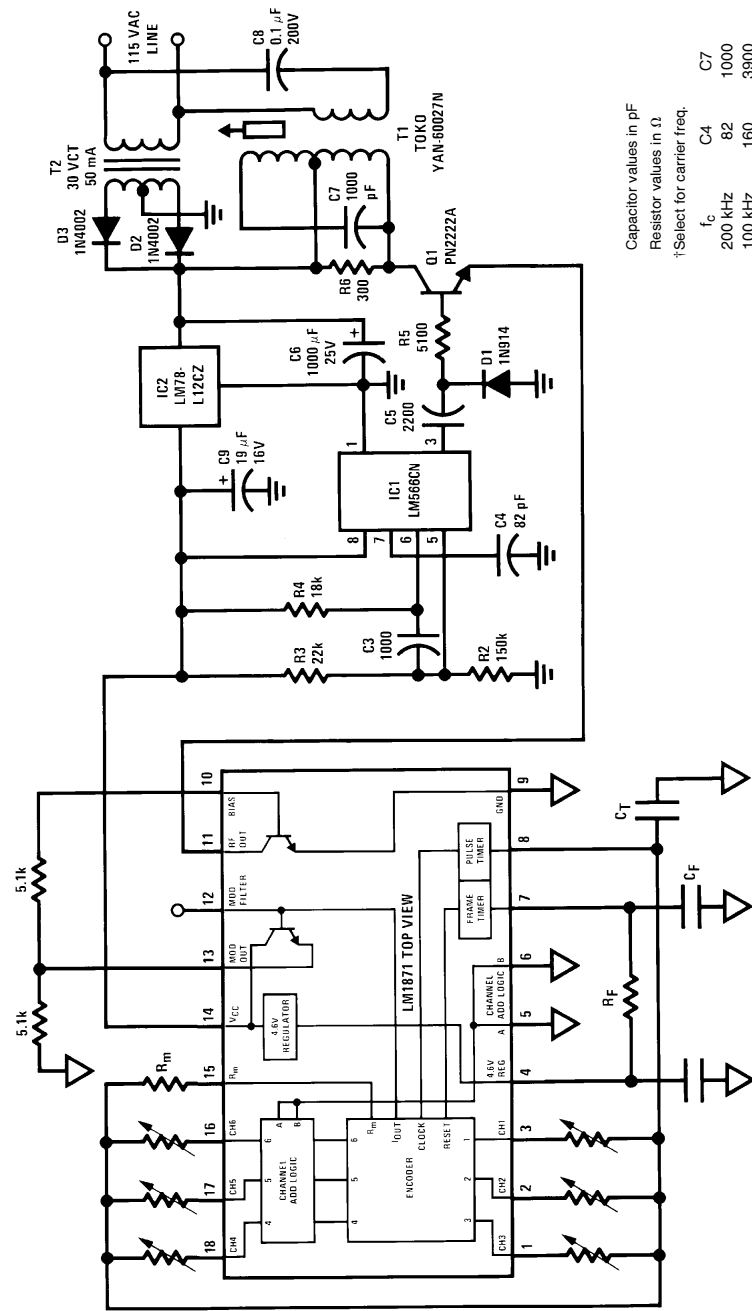

Capacitor values in pF
 Resistor values in Ω
 †Select for carrier freq.

f _c	C4	C7
200 kHz	82	1000
100 kHz	160	3900

TL/H/7911-18

FIGURE 8. LM1871, LM566 200 kHz Line Carrier Transmitter with ON/OFF Carrier Modulation

Additional Applications (Continued)

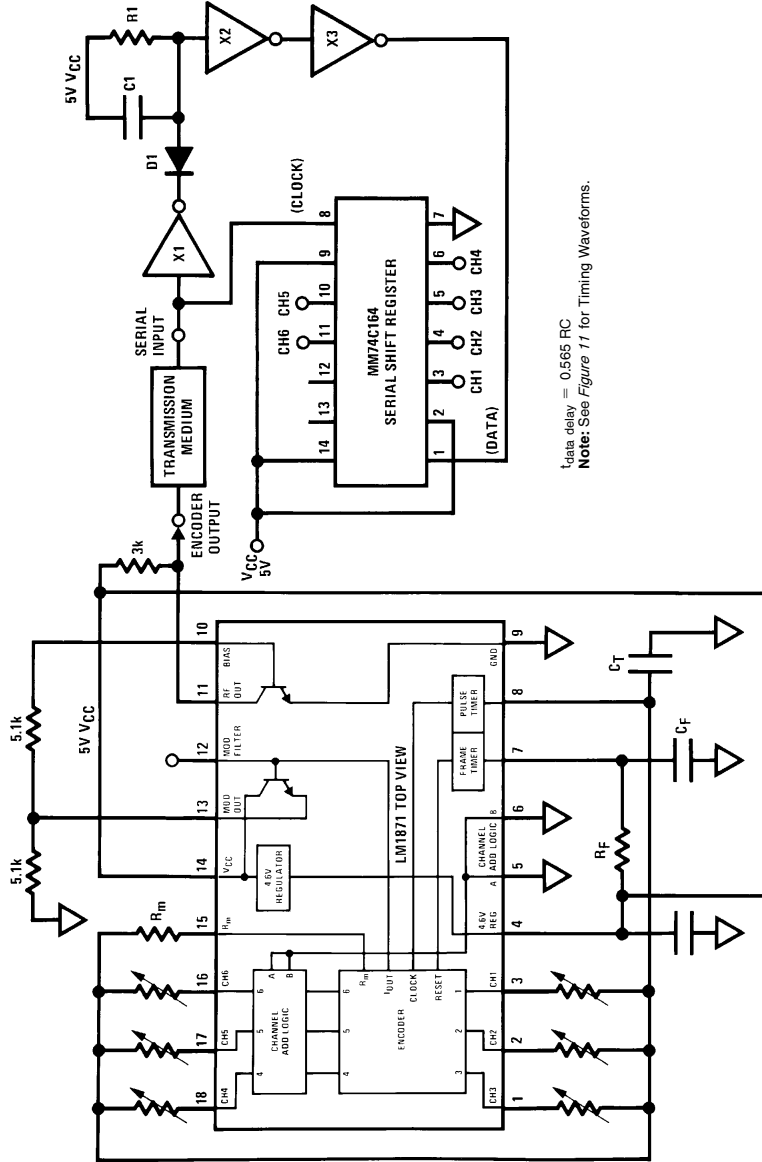

t_{data delay} = 0.5665 RC
 Note: See Figure 71 for Timing Waveforms.

TL/H7911-19

FIGURE 9. LM1871 Six Analog Channel Encoder with TTL Compatible Output **FIGURE 10. Six Analog Channel Detector**

Additional Applications (Continued)

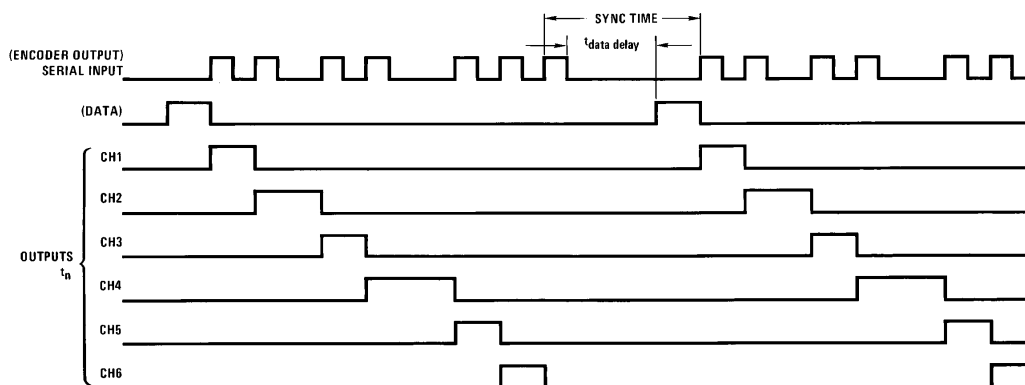

TL/H/7911-20

FIGURE 11. Six Analog Channel Detector Waveforms

LM1871 Component Selection Guide

Component	Min	Typ	Max	Comments
R _F	2 kΩ	180 kΩ	1M	Pin 7. Frame timer resistor used with C _F to set frame time (t _f). $t_f = R_F C_F + t_m$.
C _F	500 pF	0.1 μF	0.5 μF	Pin 7. Frame timer capacitor used with R _F .
R _M	2 kΩ	150 kΩ	1M	Pin 15. Modulation timing resistor used with C _T to set mod time (t _m). $t_m = 0.63 R_M C_T$.
R _{CH}	2 kΩ	150 kΩ	1M	Channel pins 1, 2, 3, 16, 17, 18. Variable or fixed resistor used with C _T to set channel pulse widths (t _{ch}). $t_{ch} = 0.63 R_{CH} C_T$.
C _T	500 pF	0.1 μF	0.5 μF	Pin 8. Pulse timer capacitor used with R _M and R _{CH} .
C _M		0.01 μF		Pin 12. Modulation slew time (t _{ms}) capacitor used to decrease modulator bandwidth. Reduces sideband emissions. $t_{ms} = \frac{(\Delta V_{12})(C_M)}{I_{12}} = 7600 C_M$
C4		0.1 μF		Pin 4. 4.6V regulator decoupling capacitor.
C13A		1500 pF		Pin 13. Modulator output RF decoupling capacitor. Improves carrier ON to OFF ratio.
C13B		2700 PF		
C14		0.1 μF		Pin 14. V _{CC} decoupling capacitor.
R10		24 kΩ/51 kΩ		Pin 10. RF oscillator/transmitter bias resistor.

Note: See Figure 4 for RF components. All timing capacitors should be low-drift (NPO) types.

Schematic Diagram

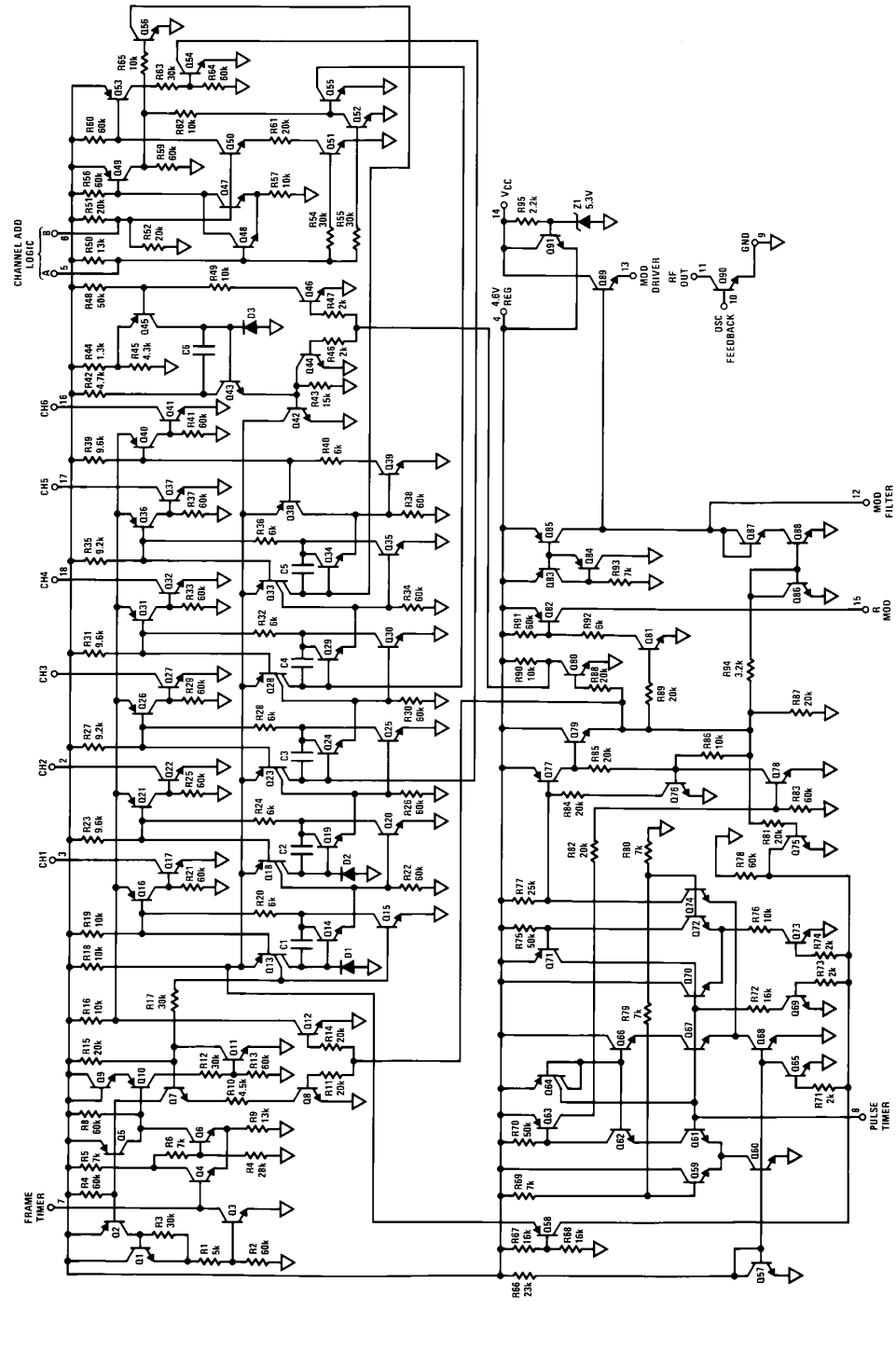

TL/H/7911-21

FIGURE 12



Physical Dimensions inches (millimeters)

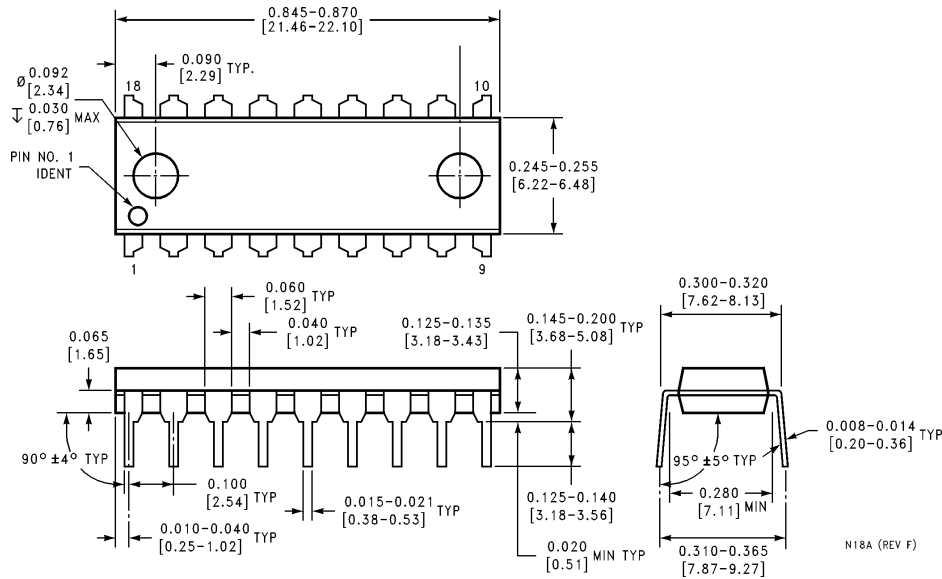

Molded Dual-In-Line Package (N)
Order Number LM1871N
NS Package Number N18A

LIFE SUPPORT POLICY

NATIONAL'S PRODUCTS ARE NOT AUTHORIZED FOR USE AS CRITICAL COMPONENTS IN LIFE SUPPORT DEVICES OR SYSTEMS WITHOUT THE EXPRESS WRITTEN APPROVAL OF THE PRESIDENT OF NATIONAL SEMICONDUCTOR CORPORATION. As used herein:

1. Life support devices or systems are devices or systems which, (a) are intended for surgical implant into the body, or (b) support or sustain life, and whose failure to perform, when properly used in accordance with instructions for use provided in the labeling, can be reasonably expected to result in a significant injury to the user.
2. A critical component is any component of a life support device or system whose failure to perform can be reasonably expected to cause the failure of the life support device or system, or to affect its safety or effectiveness.



National Semiconductor Corporation
 1111 West Bardin Road
 Arlington, TX 76017
 Tel: 1(800) 272-9959
 Fax: 1(800) 737-7018

National Semiconductor Europe
 Fax: (+49) 0-180-530 85 86
 Email: cnjwge@tevm2.nsc.com
 Deutsch Tel: (+49) 0-180-530 85 85
 English Tel: (+49) 0-180-532 78 32
 Français Tel: (+49) 0-180-532 93 58
 Italiano Tel: (+49) 0-180-534 16 80

National Semiconductor Hong Kong Ltd.
 19th Floor, Straight Block,
 Ocean Centre, 5 Canton Rd.
 Tsimshatsui, Kowloon
 Hong Kong
 Tel: (852) 2737-1600
 Fax: (852) 2736-9960

National Semiconductor Japan Ltd.
 Tel: 81-043-299-2309
 Fax: 81-043-299-2408

National does not assume any responsibility for use of any circuitry described, no circuit patent licenses are implied and National reserves the right at any time without notice to change said circuitry and specifications.