

1dB LSB GaAs MMIC 5-BIT DIGITAL ATTENUATOR, DC - 4 GHz

Typical Applications

The HMC307QS16G is ideal for:

- Cellular
- PCS, ISM, MMDS
- Wireless Local Loop

Features

- 1 dB LSB Steps to 31 dB
- Single Control Line Per Bit
- +/- 0.5 dB Typical Bit Error
- Miniature QSOP-16 Package: 29.4 mm²

Functional Diagram

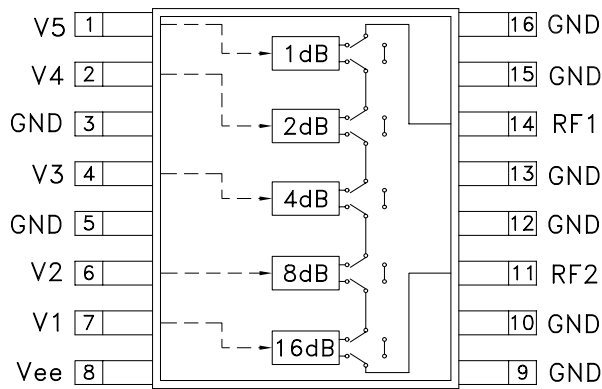

General Description

The HMC307QS16G is a broadband 5-bit GaAs IC digital attenuator in a 16 lead QSOP grounded base surface mount plastic package. Covering DC to 4 GHz, the insertion loss is less than 2 dB typical. The attenuator bit values are 1 (LSB), 2, 4, 8, and 16 dB for a total attenuation of 31 dB. Attenuation accuracy is excellent at ± 0.5 dB typical with an IIP3 of up to +44 dBm. Five bit control voltage inputs, toggled between 0 and -5V, are used to select each attenuation state at less than 50 uA each. A single Vee bias of -5V allows operation down to DC. This product is an excellent alternative to the HMC235QS16G.

Electrical Specifications, $T_A = +25^\circ C$, $V_{ee} = -5V$ & $V_{CTL} = 0/V_{ee}$

| Parameter | Frequency | Min. | Typical | Max. | Units |
|--|---------------|--|---------|------|-------|
| Insertion Loss | DC - 1.4 GHz | | 1.8 | 2.2 | dB |
| | 1.4 - 2.3 GHz | | 1.9 | 2.4 | dB |
| | 2.3 - 2.7 GHz | | 2.0 | 2.5 | dB |
| | 2.7 - 4.0 GHz | | 2.1 | 2.7 | dB |
| Attenuation Range | DC - 4.0 GHz | | 31 | | dB |
| Return Loss (RF1 & RF2, All Atten. States) | DC - 1.4 GHz | 11 | 15 | | dB |
| | 1.4 - 2.3 GHz | 11 | 17 | | dB |
| | 2.3 - 2.7 GHz | 10 | 18 | | dB |
| | 2.7 - 4.0 GHz | 8 | 15 | | dB |
| Attenuation Accuracy: (Referenced to Insertion Loss) | DC - 2.7 GHz | $\pm 0.2 + 3\%$ of Atten. Setting Max | | | dB |
| | DC - 2.7 GHz | $\pm 0.3 + 5\%$ of Atten. Setting Max | | | dB |
| | 2.7 - 4.0 GHz | $\pm 0.3 + 5\%$ of Atten. Setting Max | | | dB |
| | 2.7 - 4.0 GHz | $\pm 0.6 + 10\%$ of Atten. Setting Max | | | dB |
| Input Power for 0.1 dB Compression | 0.5 - 4.0 GHz | | 24 | | dBm |
| Input Third Order Intercept Point (Two-tone Input Power = 0 dBm Each Tone) | 0.5 - 4.0 GHz | | 44 | | dBm |
| Switching Characteristics | DC - 4.0 GHz | | | | |
| | | tRISE, tFALL (10/90% RF) | | 140 | ns |
| | | tON, tOFF (50% CTL to 10/90% RF) | | 160 | ns |

1 dB LSB GaAs MMIC 5-BIT DIGITAL ATTENUATOR, DC - 4 GHz

Insertion Loss

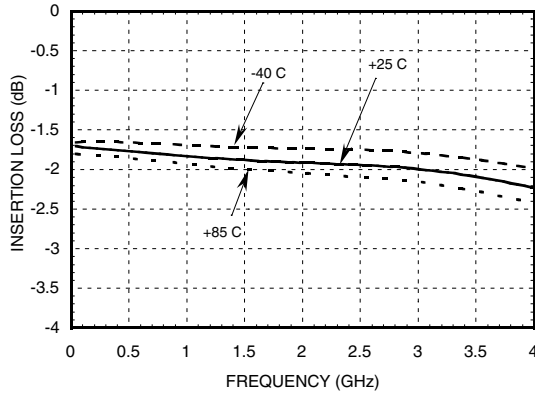

Return Loss RF1, RF2
(Only Major States are Shown)

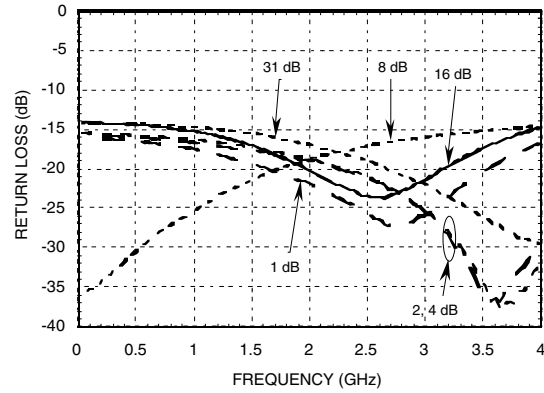

Normalized Attenuation
(Only Major States are Shown)

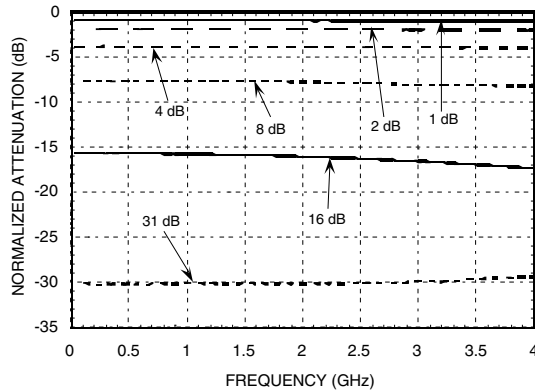

Absolute Bit Error vs. Attenuation State

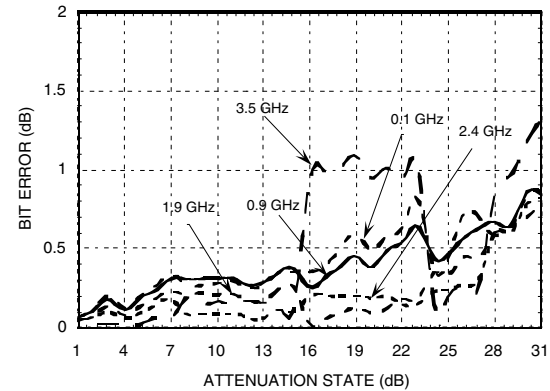

Absolute Bit Error vs. Frequency
(Only Major States are Shown)

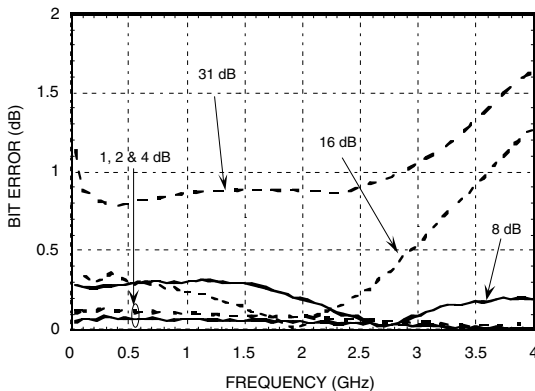

Relative Phase vs. Frequency
(Only Major States are Shown)

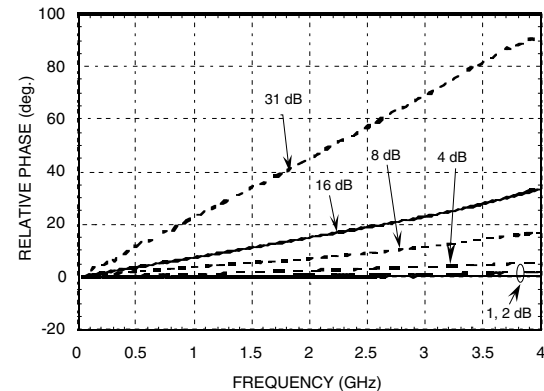

1 dB LSB GaAs MMIC 5-BIT DIGITAL ATTENUATOR, DC - 4 GHz

Application Circuit

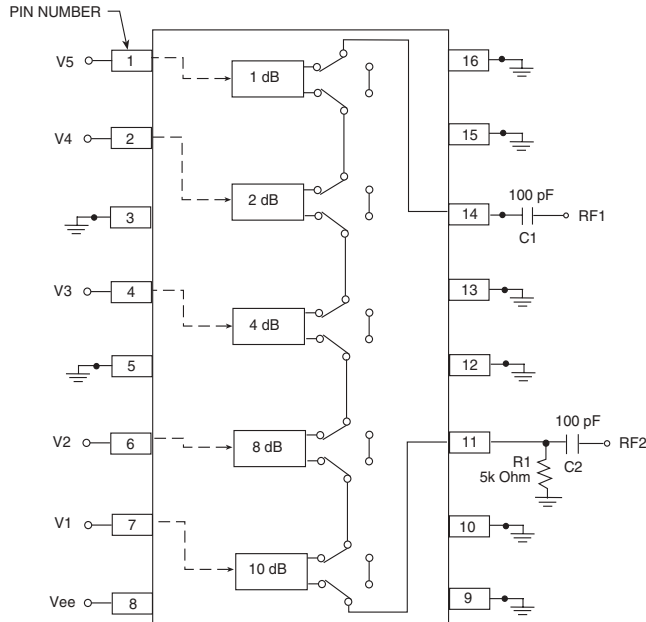

DC Blocking Capacitors C1 & C2 are required on RF1 & RF2. Choose C1 = C2 = 100 pF ~ 0.1 uF to allow lowest customer specific frequency to pass with minimal loss. R1= 5K Ohm is required to supply voltage to the circuit through either Pin 11 or Pin 14.

Truth Table

| Control Voltage Input | | | | | Attenuation State RF1 - RF2 |
|-----------------------|------------|------------|------------|------------|--------------------------------|
| V1 16 dB | V2 8 dB | V3 4 dB | V4 2 dB | V5 1 dB | |
| Low | Low | Low | Low | Low | Reference I.L. |
| Low | Low | Low | Low | High | 1 dB |
| Low | Low | Low | High | Low | 2 dB |
| Low | Low | High | Low | Low | 4 dB |
| Low | High | Low | Low | Low | 8 dB |
| High | Low | Low | Low | Low | 16 dB |
| High | High | High | High | High | 31 dB Max. Atten. |

Any combination of the above states will provide an attenuation approximately equal to the sum of the bits selected.

Control Voltage

| State | Bias Condition |
|-------|------------------------|
| Low | 0 to -3V @ 70 uA Typ. |
| High | Vee + 0.8V @ 5 uA Typ. |

Note: Vee = -5V ± 10%

Bias Voltage & Current

| Vee Range = -5.0 Vdc ± 10% | | |
|----------------------------|-----------------------------|-----------------------------|
| Vee (VDC) | I _{ee} (Typ.) (mA) | I _{ee} (Max.) (mA) |
| -5.0 | 3 | 6 |

1 dB LSB GaAs MMIC 5-BIT DIGITAL ATTENUATOR, DC - 4 GHz

Suggested Driver Circuit (One Circuit Required Per Bit Control Input)

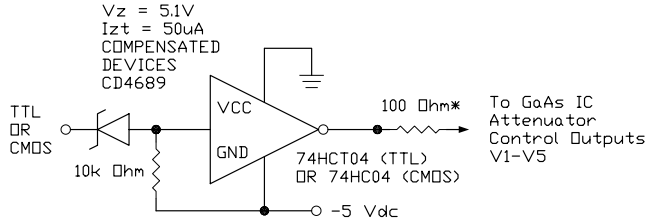

Simple driver using inexpensive standard logic ICs provides fast switching using minimum DC current. * Recommended value to suppress unwanted RF signals at V1 - V5 control lines.

Absolute Maximum Ratings

| | |
|------------------------------|----------------|
| Control Voltage (V1 - V5) | Vee - 0.5 Vdc |
| Bias Voltage (Vee) | -7.0 Vdc |
| Storage Temperature | -65 to +150 °C |
| Operating Temperature | -40 to +85 °C |
| RF Input Power (0.5 - 4 GHz) | +26 dBm |

Outline Drawing

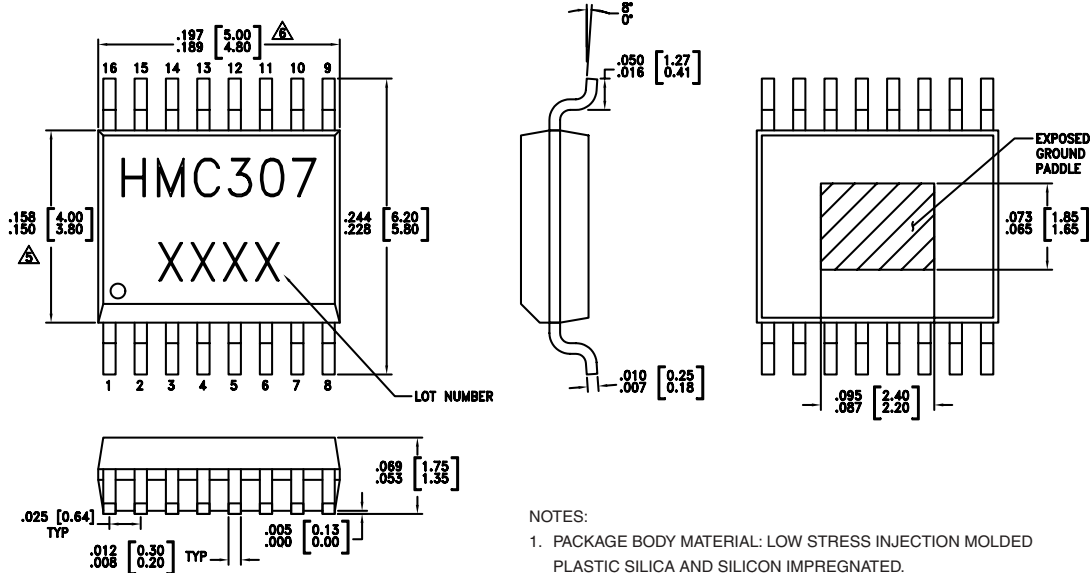

- NOTES:
1. PACKAGE BODY MATERIAL: LOW STRESS INJECTION MOLDED PLASTIC SILICA AND SILICON IMPREGNATED.
 2. LEADFRAME MATERIAL: COPPER ALLOY
 3. LEADFRAME PLATING: Sn/Pb SOLDER
 4. DIMENSIONS ARE IN INCHES [MILLIMETERS].
 5. DIMENSION DOES NOT INCLUDE MOLDFLASH OF 0.15mm PER SIDE.
 6. DIMENSION DOES NOT INCLUDE MOLDFLASH OF 0.25mm PER SIDE.
 7. ALL GROUND LEADS AND GROUND PADDLE MUST BE SOLDERED TO PCB RF GROUND.

1 dB LSB GaAs MMIC 5-BIT DIGITAL ATTENUATOR, DC - 4 GHz

Evaluation Circuit Board

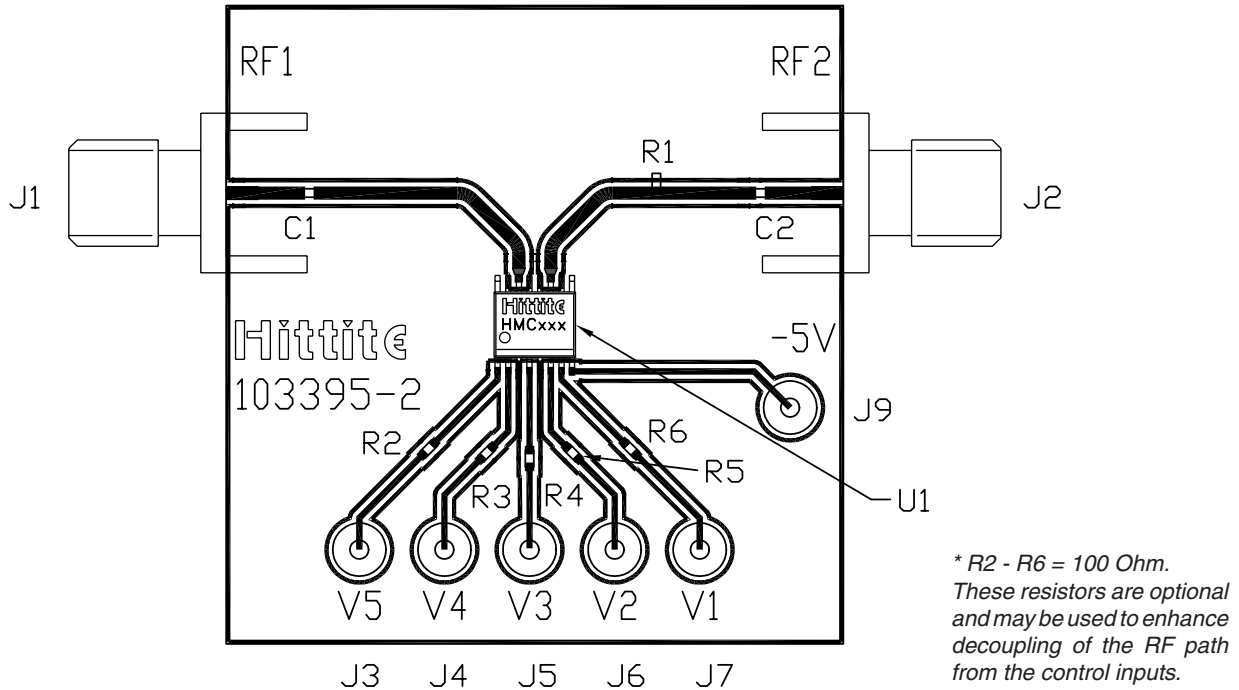

The circuit board used in the final application should use RF circuit design techniques. Signal lines should have 50 ohm impedance while the package ground leads and exposed paddle should be connected directly to the ground plane similar to that shown. A sufficient number of via holes should be used to connect the top and bottom ground planes. The evaluation circuit board shown is available from Hittite upon request.

List of Material

| Item | Description |
|---------|---|
| J1 - J2 | PC Mount SMA Connector |
| J3 - J9 | DC Pin |
| R1 | 5k Ohm Resistor, 0402 Pkg. |
| R2 - R6 | 100 Ohm Resistor, 0402 Pkg. |
| C1, C2 | 0402 Chip Capacitor, Select Value for Lowest Frequency of Operation |
| U1 | HMC307QS16G Digital Attenuator |
| PCB* | 103395 Evaluation PCB 1.5" x 1.5" |

*Circuit Board Material: Rogers 4350

1 dB LSB GaAs MMIC 5-BIT DIGITAL ATTENUATOR, DC - 4 GHz

Notes: