

ALC Module

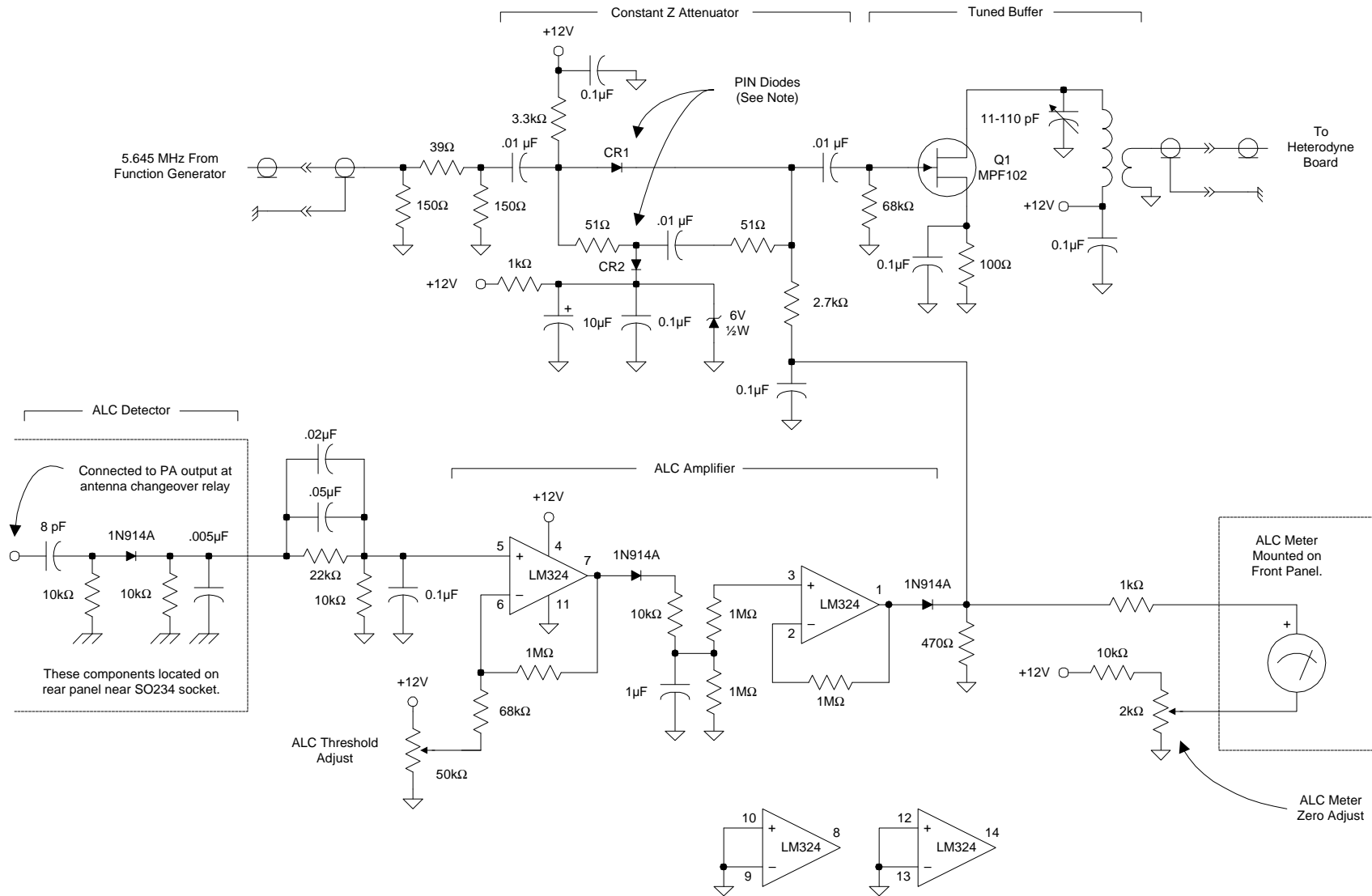

K9GDT 40m Multimode Transmitter

Notes:
CR1, CR2 - Unidentified "Hamfest" PIN Diode (MFR Unknown)

by George!
9/11/95

Chassis Wiring

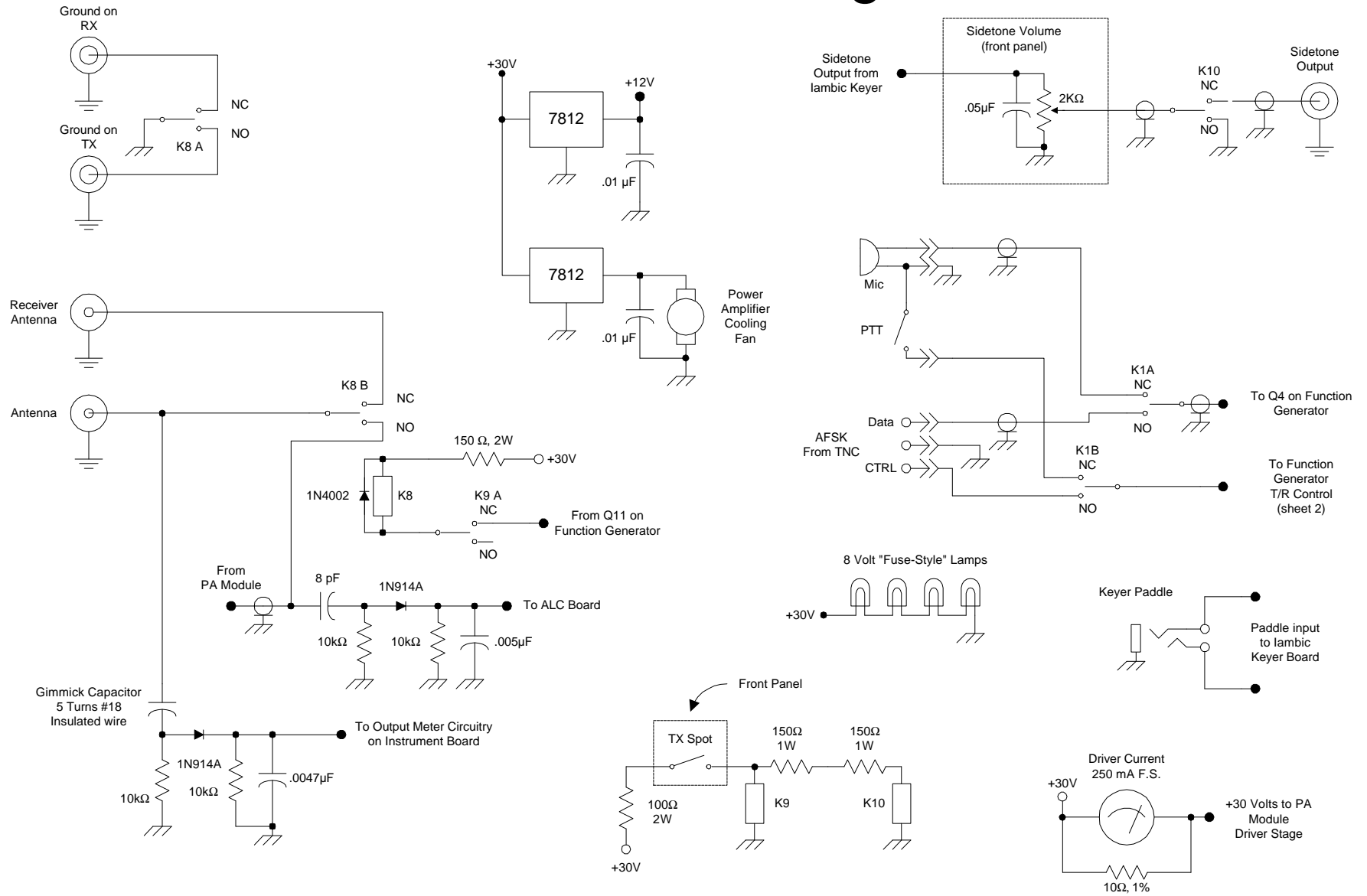

Function Generator

Sheet 2 of 2
Control Circuitry

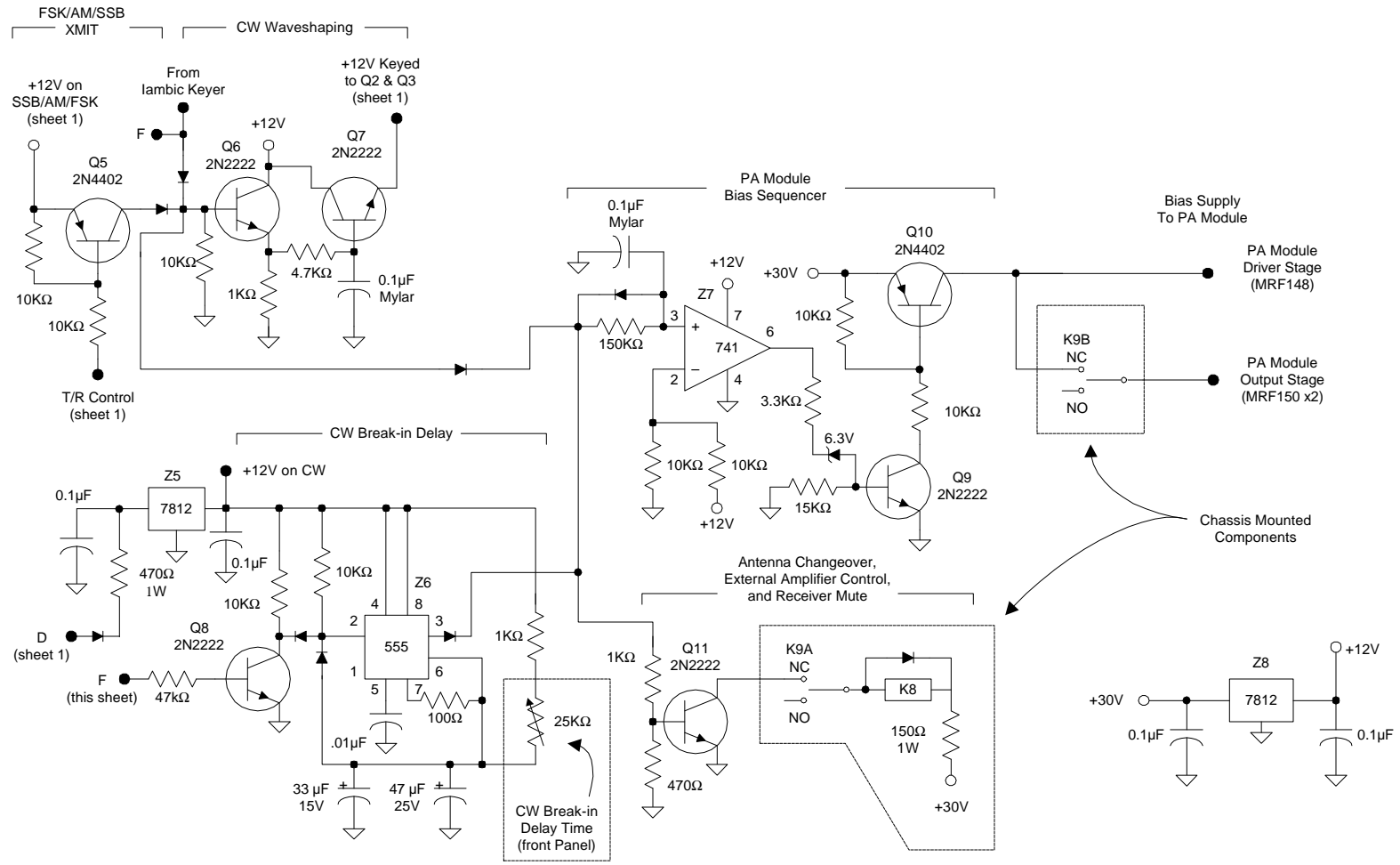

Iambic Keyer

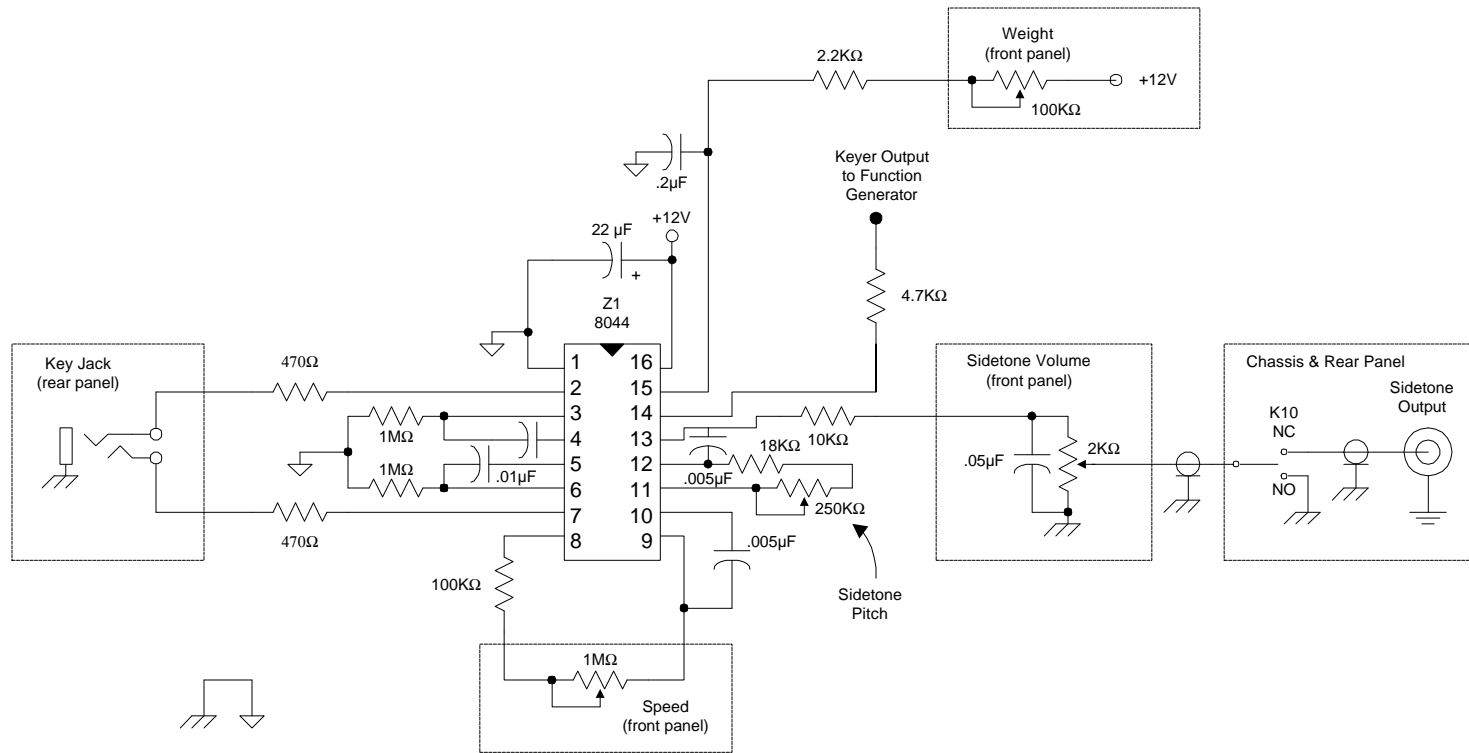

Instrument Board

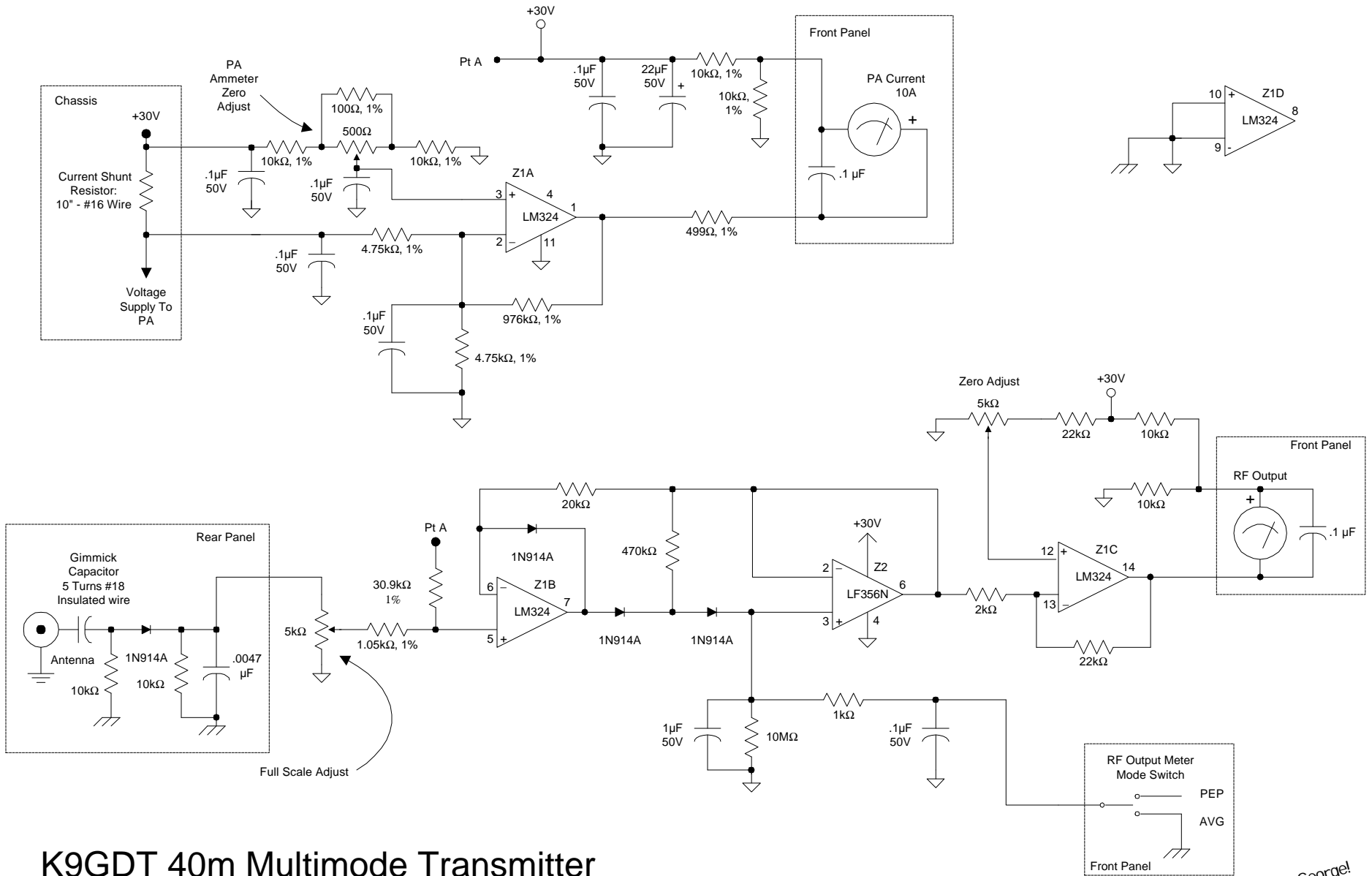

K9GDT 40m Multimode Transmitter

by George!
7/24/95

Tuning Assembly

4.955 - 5.455 MHz to Heterodyne Board

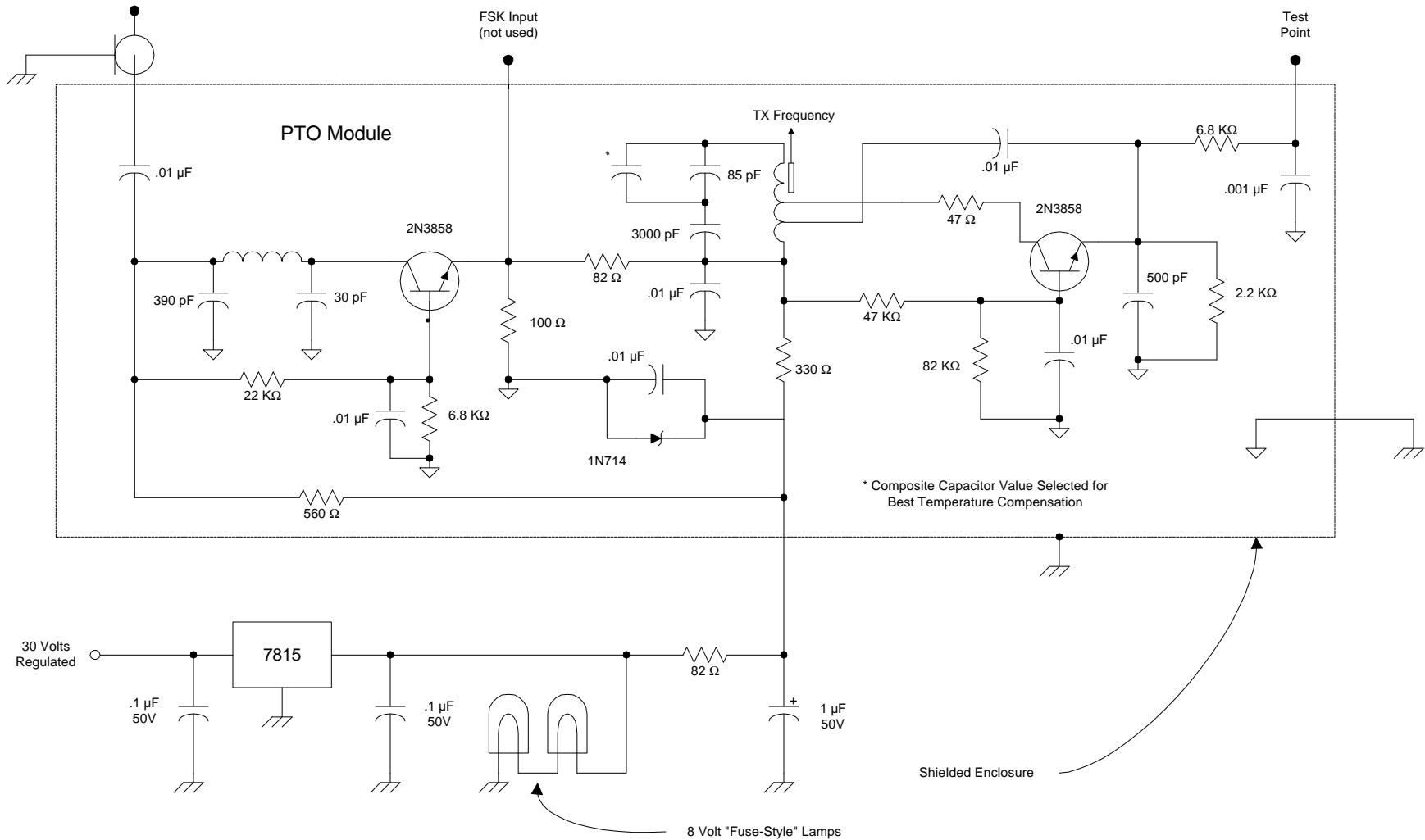

K9GDT 40m Multimode Transmitter

by George!
7/21/95