

LUDLUM MODEL 2220
PORTABLE SCALER RATEMETER
JANUARY 1987



LUDLUM MEASUREMENTS, INC.

501 OAK ST., P.O. BOX 810
SWEETWATER, TX 79556
325/235-5494 FAX: 325/235-4672

LUDLUM MODEL 2220 PORTABLE SCALER RATEMETER

TABLE OF CONTENTS

	Page No.
1. GENERAL	2
2. SPECIFICATIONS	2
3. DESCRIPTION OF CONTROLS AND FUNCTIONS	3
4. OPERATING PROCEDURES	4
5. DETERMINING INSTRUMENT PLATEAU AND SELECTING OPERATING POINT	5
6. WINDOW OPERATION AND ENERGY CALIBRATION PROCEDURES	6
7. BILLS OF MATERIALS AND SCHEMATICS	8

LUDLUM MODEL 2220 PORTABLE SCALER RATEMETER

1. GENERAL

The Ludlum Model 2220 Portable Scaler Ratemeter is a self-contained counting instrument designed for operation with scintillation, proportional or G-M detectors. Power is derived from four flashlight batteries. The unit is complete with a voltage-sensitive preamplifier, linear amplifier, electronic timer and detector high-voltage power supply. A single channel analyzer is also featured in this unit for use in gamma spectrum analysis. The analyzer may be switched on or off, allowing gross window counting. Potentiometers are supplied for threshold, window and high-voltage controls.

2. SPECIFICATIONS

HIGH VOLTAGE: 0 to 2500 volts with digital readout

BATTERY COMPLEMENT: four each "D" cell flashlight batteries

BATTERY LIFE: approximately 20 hours with Duracell batteries (MN1300, size D, alkaline batteries)

CALIBRATION STABILITY: less than 15% variance to battery endpoint

SENSITIVITY: voltage-sensitive and adjustable from 1.3 mV to 400 mV; factory calibrated at 10 mV

INPUT IMPEDANCE: 22K

READOUT: liquid crystal display with pushbutton light

METER: 2 1/2-inch scale, 50 micro-amp, taut-band suspension

SCALE: four-decade logarithmic scale to 500K Counts per Minute (CPM); 0-500 Counts per Minute with multipliers of X1K, X100, X10, X1

RANGE: 0 to 500,000 Counts per Minute

LINEARITY: plus or minus 5% of full scale

RESPONSE: 2 positions, fast 3 seconds, slow 15 seconds, for 67% of full deflection

CALIBRATION CONTROLS: recessed screwdriver adjustments

AUDIO: built-in unimorph speaker with automatic pitch change in relation to meter reading

LUDLUM MODEL 2220 PORTABLE SCALER RATEMETER

CONNECTOR: Series "C"

SIZE: 9 1/2 inches long, 3 3/4 inches wide, 5 inches high (exclusive of handle)

WEIGHT: 5 1/2 pounds, including 4 each "D" cell batteries

FINISH: computer beige polyurethane enamel with silk-screened nomenclature

3. DESCRIPTION OF CONTROLS AND FUNCTIONS

COUNT Button resets and starts the scaler counting. The scaler turns off at the end of the preset time.

ZERO Button, when depressed, causes the meter to reset.

HOLD Button stops the count cycle without resetting the scaler display.

LIGHT Button, when depressed, lights up the meter and the LCD readout.

F/S RESP is a 2-position toggle switch indicating fast or slow meter response. In "F" position, the meter will deflect 67% of full scale in 3 seconds. In "S" position, the meter will deflect 67% of full scale in 15 seconds.

ON/OFF AUDIO Toggle Switch in the ON position operates the unimorph speaker, located on the left side of the instrument. The frequency is relative to the meter deflection. The higher the deflection is, the higher the audio frequency. The audio should be turned OFF when not required to reduce battery drain.

BAT, when depressed, causes the battery voltage to be displayed on the display in 1/100 volts (0500 is 5.00 volts).

RANGE Multiplier Selector Switch is a 6-position switch marked OFF, LOG, X1K, X100, X10, X1. Turning the range selector switch from OFF to LOG position provides the operator with a logarithmic scale that corresponds to the top scale of the meter. Moving the RANGE selector switch to one of the range multiplier positions (X1K, X100, X10, X1) provides the operator with an overall range of 0-500,000 Counts per Minute. Multiply the scale reading by the multiplier for determining the actual reading.

NOTE: Reading the CPM scale when the range multiplier switch is in the LOG position will give wrong information.

LUDLUM MODEL 2220 PORTABLE SCALER RATEMETER

COUNT TIME MINUTES is a 4-position switch used for presetting count time. Time base is in minutes with time settings of 0.1, 0.5, and 1.0. A CONT (continuous) position is also provided for manual timing.

WINDOW, when depressed, indicates the window width. This width is displayed on the readout from 0000 to 1000. NOTE: The WINDOW IN/OUT Toggle Switch must be in the IN position for proper reading.

IN/OUT Toggle Switch allows insertion (IN) or removal (OUT) of the window.

THRESH indicates the base line (or discrimination point) and displays on the readout from 0000 to 1000. NOTE: Operation below 0100 is not recommended.

HV, when depressed, indicates the setting of the HV on the readout from 0000 to 2500 volts.

CALIBRATE Adjustments are potentiometers on line with WINDOW, THRESH and HV. These potentiometers adjust their respective functions.

4. OPERATING PROCEDURES

4.1 Installing Batteries

- a. Unsnap Corbin latches and remove the can.
- b. Install four "D" size batteries in the battery holder. The correct position of the batteries is indicated on the bottom of the battery holder.
- c. Place instrument back into the can.

4.2 Operating the Instrument

- a. Turn RANGE switch to LOG position. The meter should peg and then return to approximately 50 on the top scale of the meter. The LCD readout should turn on.
- b. Press COUNT button. The display should zero. Two colons should appear on the display.
- c. Press HOLD button. The colons should disappear.

LUDLUM MODEL 2220 PORTABLE SCALER RATEMETER

4.3 Operating Point

Instrument and detector operating point is established by setting the probe voltage (HV) and instrument sensitivity (THRESH). For a given detector system, efficiency, background and noise are fixed by the physical makeup of the detector and rarely vary from unit to unit. However, the selection of the operating point makes a marked difference in the apparent contribution of these three sources of count.

In the singular case of the G-M detector, a minimum operating voltage is required to establish the G-M operating region. (At lower voltages, the detector operates as a very insensitive proportional counter.) This detector is not capable of energy discrimination (pulse-height discrimination).

For gain sensitive detectors (proportional or scintillation), the most straightforward method of selecting the operating point is to develop a graph, relating count rate to system gain. This relationship is commonly referred to as a plateau or instrument plateau curve. System gain may be changed by adjusting detector high voltage or THRESH control.

4.4 Limitation of Controls

HV Control provides a linear adjustment of the detector voltage supply. The range is approximately 0 to 2500 volts through the full potentiometer. Changing the detector voltage will cause the detector gain to change. It should be remembered that a linear change in voltage will cause an exponential change in detector gain.

THRESH Control sets the basic pulse discrimination point of the scaler.

WINDOW Control is calibrated with the THRESH control so that the reading of the WINDOW control is equivalent to the reading of the THRESH control. As an example, 0100 on the THRESH is equal to 0100 on the WINDOW.

5. DETERMINING INSTRUMENT PLATEAU AND SELECTING OPERATING POINT

- 5.1 Set WINDOW ON/OFF to OFF.
- 5.2 Set COUNT TIME switch to 0.1 minutes.
- 5.3 Set THRESH control at 100.

LUDDLUM MODEL 2220 PORTABLE SCALER RATEMETER

- 5.4 With detector shielded from source, turn up high voltage control 100 volts at a time and take a plot of HV versus background count rate until the detector voltage rating is reached. Return HV control to 0.0.
NOTE: If detector voltage rating is reached before any background counts are detected, the internal gain control needs to be adjusted to increase sensitivity.
- 5.5 Expose the detector to a source and again make a plot of voltage versus count, using 50-volt increments.
- 5.6 Plot both sets of data and select the operating point to correspond with maximum source count and minimum background count. Avoid areas of very fast count rate changes with small changes in detector voltage. The optimum operating point for low background detectors is just above the inflection point (or break-over point) of the plateau curve. If background count is irrelevant, shift operating point to the plateau center for greater stability.

6. WINDOW OPERATION AND ENERGY CALIBRATION PROCEDURES

The following procedure calibrates threshold directly in KEV.

- 6.1 Place RANGE multiplier switch to LOG position.
 - a. Unsrew and remove CAL cover.
 - b. Press HV Button. The HV should read out on the display directly in volts. While depressing the HV button, turn HV potentiometer maximum counterclockwise. The HV should be less than 50 volts.
 - c. Depress the THRESH button. Turn the THRESH potentiometer clockwise until 0652 displays.
 - d. With WINDOW IN/OUT switch IN, depress the WINDOW button. Turn the WINDOW potentiometer until 0020 appears on the display.
 - e. Switch WINDOW IN/OUT to OUT.
 - f. Connect the probe and expose to Cs137 source.
 - g. Increase HV (if HV potentiometer is at minimum, it will take approximately 3 turns before any change is indicated). While increasing the HV, observe the log scale of the ratemeter. Increase HV until ratemeter indication occurs.

LUDLUM MODEL 2220 PORTABLE SCALER RATEMETER

- h. Switch WINDOW IN/OUT switch to IN.
 - i. Turn the HV control until maximum reading occurs on the log scale. Increase HV until reading starts to drop off, then decrease the HV for maximum reading.
- 6.2 Turn RANGE selector switch to the X1K position.
- a. Press ZERO button. If meter does not read, switch to a lower range until a reading occurs.
 - b. Carefully adjust HV potentiometer until maximum reading is achieved on the range scale. The instrument is now peaked for Cs137 on both the LOG and RANGE scales.

NOTE: When the THRESH control is adjusted, the effective window width remains constant. As an example, if the THRESH is set at 0612, the WINDOW at 0100, a 662 KEV peak $0612 + (0100 \text{ divided by } 2)$ will be centered in the window. Then the threshold point is equivalent to 612 KEV with a 100 KEV window and calibrated for 100 KEV per turn. Now if the threshold is reduced to 0250, the threshold is equivalent to 250 KEV, but the window (0100) is still equal to 100 KEV. Proportionally, this represents a broader window.

LUDLUM MODEL 2220 PORTABLE SCALER RATEMETER

BILL OF MATERIALS

COUNTER BOARD, DRAWING NO. 261 X 06

CAPACITORS

C1	22MF, 15V, OST	04-5579
C2	.01MF, 100V, C	04-5523
C3	.001MF, 100V, C	04-5519
C4	22MF, 15V, OST	04-5579
C5	220PF, 100V, C	04-5530
C6	1MF, 35V, OST	04-5575
C7-C8	.47MF, 35V, DT	04-5591

INTEGRATED CIRCUITS

U1-U6	CD4056	06-6095
U7	CD4071	06-6035
U8	CD4019	06-6028
U9-U10	CD4071	06-6035
U11	CD4072	06-6039
U12	CD4071	06-6035
U13	ADC3711	06-6133
U14	CD4093	06-6030
U15	CD4001	06-6064
U16	LS7031	06-6114
U17	CA3290	06-6140
U18	CD4077	06-6119

RESISTORS

R1-R3	100K	10-7023
R4	243K 1%	12-7549
R5	100K 1%	12-7557
R6	100K	10-7023
R7	2.2 MEG	10-7023
R8	560K	10-7027
R9	220K	10-7066
R10	6.8K	10-7047
R11	10K TRIMMER POTENTIOMETER	09-6794
R12	33K	10-7019
R13	100K	10-7023
R14	50K TRIMMER POTENTIOMETER	09-6790
R15	200 OHM	10-7006
R16	100K	10-7023
R17	47K	10-7020
R18	22K	10-7070
R19	22 MEG	10-7034

LUDLUM MODEL 2220 PORTABLE SCALER RATEMETER

BILL OF MATERIALS

POWER SUPPLY/CLOCK BOARD, DRAWING NO. 261 X 16

CRYSTAL

Y1	1.000 MHZ	01-5149
----	-----------	---------

CAPACITORS

C1	.022MF, 100V, C	04-5568
C2	1MF, 35V, OST	04-5575
C3	100MF, 10V, OST	04-5576
C4	10MF, 20V, DT	04-5592
C5	100MF, 10V, OST	04-5576
C6	4.7MF, 10V, OST	04-5578
C7	.1MF, 100V, C	04-5521
C8	100MF, 10V, OST	04-5576
C9	.01MF, 100V, C	04-5523
C10	.1MF, 100V, C	04-5521
C11	1MF, 35V, OST	04-5575
C12-C13	.0015MF, 3KV, C	04-5518
C14-C16	.0056MF, 3KV, C	04-5522
C17	.002MF, 1KV, C	04-5571
C18	100PF, 3KV, C	04-5532
C19	.01MF, 100V, C	04-5523
C20	.1MF, 100V, C	04-5521
C21	100MF, 10V, OST	04-5576

TRANSISTORS

Q1	2N2714	05-5755
Q2	MPS6534	05-5763
Q3	MJE2801	05-5766
Q4	MPSU51	05-5765
Q5	2N2714	05-5755
Q6	MPS6534	05-5763
Q7	2N2714	05-5755

INTEGRATED CIRCUITS

U1	ICM7555	06-6136
U2-U3	LM358	06-6024
U4	CD4052	06-6141
U5	LM358	06-6024
U6	CA3290	06-6140
U7	CD4011	06-6014

LUDLUM MODEL 2220 PORTABLE SCALER RATEMETER

U8	RDD104	
U9	CD4093	06-6060
U10	RED360/300	06-6030
U11	CD40102	06-6018
		06-6062

VOLTAGE REGULATORS

VRI	78L05A	05-5815
-----	--------	---------

DIODES

CR1	1N4001	
CR2	LM385Z-1.2	07-6268
CR3-CR10	1N4148	05-5808
CR11-CR14	MR250-2	07-6272
CR15	1N5231	07-6266
CR16	1N4148	07-6261
		07-6272

RESISTORS

R1	10K	
R2	22K	10-7016
R3	100K	10-7070
R4	10K	10-7023
R5	100K	10-7016
R6	10K	10-7023
R7	33K	10-7016
R8	1K	10-7019
R9	10K	10-7009
R10	100K	10-7016
R11	1 MEG	10-7023
R12	100K	10-7028
R13-R14	100K TRIMMER POTENTIOMETER	10-7023
R15	56K	09-6797
R16	100K 1%	10-7021
R17-R18	374K 1%	12-7557
R19	10K 1%	12-7575
R20-R21	2.26K 1%	12-7540
R22-R23	22K	12-7548
R24	100K TRIMMER POTENTIOMETER	10-7070
R25	220K	09-6797
R26	270 OHM	10-7066
R27	10K	10-7007
R28	1.8K	10-7016
R29-R30	1 MEG	10-7010
R31-R33	22K	10-7028
R34	75K	10-7070
R35	100K	10-7074
R36	500K TRIMMER POTENTIOMETER	10-7023
		09-6792

LUDLUM MODEL 2220 PORTABLE SCALER RATEMETER

R37-R38	10K	10-7016
R39	470 OHM	10-7008
R40	22K	10-7070
R41	56K	10-7021
R42	10K	10-7016
R43	22 MEG	10-7034
R44	1 MEG TRIMMER POTENTIOMETER	09-6901
R45-R48	22K	10-7070
R49	47K	10-7020
R50-R51	10K TRIMMER POTENTIOMETER	09-6794
R52-R53	1G	12-7686

TRANSFORMERS

T1	LM0945	40-0945
T2	L8050	40-0902

LUDLUM MODEL 2220 PORTABLE SCALER RATEMETER

BILL OF MATERIALS

AMP/RATEMETER BOARD, DRAWING NO. 261 X 17

CAPACITORS

C1-C2	1MF, 35V, OST	04-5575
C3-C4	10MF, 20V, OST	04-5592
C5	.001MF, 100V, C	04-5519
C6	10MF, 20V, OST	04-5592
C7	.01MF, 100V, C	04-5523
C8	10PF, 1KV, NPO	04-5573
C9	47PF, 100V, C	04-5533
C10-C11	.001MF, 100V, C	04-5519
C12	1MF, 35V, OST	04-5575
C13	22PF, 100V, C	04-5552
C14-C15	100PF, 100V, C	04-5527
C16	22PF, 100V, C	04-5552
C17	220PF, 100V, C	04-5530
C18	1MF, 35V, OST	04-5575
C19	100MF, 10V, OST	04-5576
C20	.1MF, 100V, C	04-5521
C21	1MF, 35V, OST	04-5575
C22	22MF, 15V, OST	04-5579
C23	10MF, 20V, OST	04-5592
C24-C25	.1MF, 100V, C	04-5521
C26	1MF, 35V, OST	04-5575
C27	.1MF, 100V, C	04-5521
C28	.0047MF, 100V, P	04-5513

TRANSISTORS

Q1	2N2714	05-5755
----	--------	---------

INTEGRATED CIRCUITS

U1-U3	CA3096	06-6023
U4	CA3290	06-6140
U5	LM358	06-6024
U6-U7	CA3096	06-6023
U8-U9	CD4098	06-6066
U10	LM358	06-6024
U11	CA3290	06-6140

LUIDLUM MODEL 2220 PORTABLE SCALER RATEMETER

VOLTAGE REGULATOR

VRL	78L05	05-5815
-----	-------	---------

DIODES

CR1-CR2	1N4148	07-6272
CR3-CR4	LM385Z-2.5	05-5791
CR5	1N4148	07-6272

RESISTORS

R1	22K	
R2	10K	10-7070
R3	220K	10-7016
R4	10K	10-7066
R5-R6	33K	10-7016
R7	1K	10-7019
R8	10K TRIMMER POTENTIOMETER	10-7009
R9	47K	09-6794
R10	22K	10-7020
R11	10K	10-7070
R12	220K	10-7016
R13	10K	10-7066
R14	1K	10-7016
R15	5.6K	10-7009
R16	33 OHM	10-7042
R17	10K	10-7001
R18	470K	10-7016
R19	10K	10-7026
R20	1K	10-7016
R21	10K	10-7009
R22	500K TRIMMER POTENTIOMETER	10-7016
R23	1K	09-6792
R24	10K	10-7009
R25	1K	10-7016
R26	220K	10-7009
R27	4.7K	10-7066
R28	50K TRIMMER POTENTIOMETER	10-7014
R29	4.7K	09-6790
R30	100K	10-7014
R31	220K	10-7023
R32	500K TRIMMER POTENTIOMETER	10-7066
R33	10K	09-6792
R34-R35	1K	10-7016
R36	4.7K	10-7009
R37	50K TRIMMER POTENTIOMETER	10-7014
R38	4.7K	09-6790
R39	560 OHM	10-7014
R40	33K	10-7054
		10-7019

LUDLUM MODEL 2220 PORTABLE SCALER RATEMETER

R41-R42	50K TRIMMER POTENTIOMETER	09-6790
R43	33K	10-7019
R44	22K	10-7070
R45	10K	10-7016
R46	82K	10-7022
R47-R48	10K	10-7016
R49	22K	10-7070
R50	820 OHM	10-7060
R51	10K	10-7016
R52	220 OHM	10-7041
R53	100K TRIMMER POTENTIOMETER	09-7041
R54	47 MEG	10-7035
R55	10K	10-7016
R56	3.3K	10-7013
R57	22K	10-7070
R58	3.3K	10-7013
R59	22K	10-7070
R60	10K TRIMMER POTENTIOMETER	09-6794
R61	10K	10-7016
R62	22K	10-7070
R63	10K	10-7016
R64	4.7K	10-7014

LUDLUM MODEL 2220 PORTABLE SCALER RATEMETER

BILL OF MATERIALS

WIRING DIAGRAM, DRAWING NO. 261 X 31

CAPACITORS

C1	100PF, 3KV, C	04-5532
----	---------------	---------

SWITCHES

S1	ZERO	08-6517
S2	RESPONSE	08-6511
S3	AUDIO	08-6511
S4	LIGHT	08-6517
S5	RANGE	08-6501
S6	COUNT TIME	08-6502
S7	BATT.	08-6517
S8	HV TEST	08-6517
S9	WINDOW TEST	08-6517
S10	HOLD	08-6517
S11	COUNT	08-6517
S12	THRESHOLD TEST	08-6517
S13	WINDOW	08-6511

RESISTORS

R1-R3	100K POTENTIOMETER	09-6769
R4	50K POTENTIOMETER	09-6773
R5	500K POTENTIOMETER	09-6782
R6-R7	5 MEG POTENTIOMETER	09-6783
R8	22K	10-7070
R9	1 MEG	10-7028

CONNECTORS

P1-P2	50-PIN	13-7832
P3-P5	34-PIN	13-7831
P6	14-PIN SOCKET	06-6007
P7	UG706/U	13-7751

LUDLUM MODEL 2220 PORTABLE SCALER RATEMETER

MISCELLANEOUS

BI BATT. 6V. 4 EA. "D" TYPE 1.5V
6261-024-01 HV SPLITTER BOARD "BLANK"
DS1 UNIMORPH

21-9251

NO.	DEVICE	CONNECTIONS
U1	CD4071	1, 2, 3, 4, 5, 6, 7, 8, 9, 10, 11, 12, 13, 14, 15, 16, 17, 18, 19, 20
U2	CD4071	1, 2, 3, 4, 5, 6, 7, 8, 9, 10, 11, 12, 13, 14, 15, 16, 17, 18, 19, 20
U3	CD4071	1, 2, 3, 4, 5, 6, 7, 8, 9, 10, 11, 12, 13, 14, 15, 16, 17, 18, 19, 20
U4	CD4071	1, 2, 3, 4, 5, 6, 7, 8, 9, 10, 11, 12, 13, 14, 15, 16, 17, 18, 19, 20
U5	CD4071	1, 2, 3, 4, 5, 6, 7, 8, 9, 10, 11, 12, 13, 14, 15, 16, 17, 18, 19, 20
U6	CD4071	1, 2, 3, 4, 5, 6, 7, 8, 9, 10, 11, 12, 13, 14, 15, 16, 17, 18, 19, 20
U7	CD4071	1, 2, 3, 4, 5, 6, 7, 8, 9, 10, 11, 12, 13, 14, 15, 16, 17, 18, 19, 20
U8	CD4071	1, 2, 3, 4, 5, 6, 7, 8, 9, 10, 11, 12, 13, 14, 15, 16, 17, 18, 19, 20
U9	CD4071	1, 2, 3, 4, 5, 6, 7, 8, 9, 10, 11, 12, 13, 14, 15, 16, 17, 18, 19, 20
U10	CD4071	1, 2, 3, 4, 5, 6, 7, 8, 9, 10, 11, 12, 13, 14, 15, 16, 17, 18, 19, 20
U11	CD4071	1, 2, 3, 4, 5, 6, 7, 8, 9, 10, 11, 12, 13, 14, 15, 16, 17, 18, 19, 20
U12	CD4071	1, 2, 3, 4, 5, 6, 7, 8, 9, 10, 11, 12, 13, 14, 15, 16, 17, 18, 19, 20
U13	CD4071	1, 2, 3, 4, 5, 6, 7, 8, 9, 10, 11, 12, 13, 14, 15, 16, 17, 18, 19, 20
U14	CD4071	1, 2, 3, 4, 5, 6, 7, 8, 9, 10, 11, 12, 13, 14, 15, 16, 17, 18, 19, 20
U15	CD4071	1, 2, 3, 4, 5, 6, 7, 8, 9, 10, 11, 12, 13, 14, 15, 16, 17, 18, 19, 20
U16	CD4071	1, 2, 3, 4, 5, 6, 7, 8, 9, 10, 11, 12, 13, 14, 15, 16, 17, 18, 19, 20
U17	CD4071	1, 2, 3, 4, 5, 6, 7, 8, 9, 10, 11, 12, 13, 14, 15, 16, 17, 18, 19, 20
U18	CD4071	1, 2, 3, 4, 5, 6, 7, 8, 9, 10, 11, 12, 13, 14, 15, 16, 17, 18, 19, 20
U19	CD4071	1, 2, 3, 4, 5, 6, 7, 8, 9, 10, 11, 12, 13, 14, 15, 16, 17, 18, 19, 20
U20	CD4071	1, 2, 3, 4, 5, 6, 7, 8, 9, 10, 11, 12, 13, 14, 15, 16, 17, 18, 19, 20

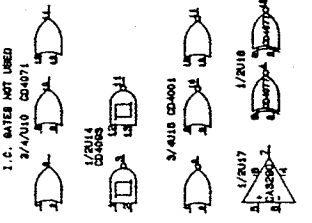
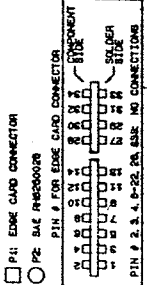

DESIGN CHANGES	00449
WORK ORDER	200
PART #	5501-000
DATE	3/26/84
DATE	11/81

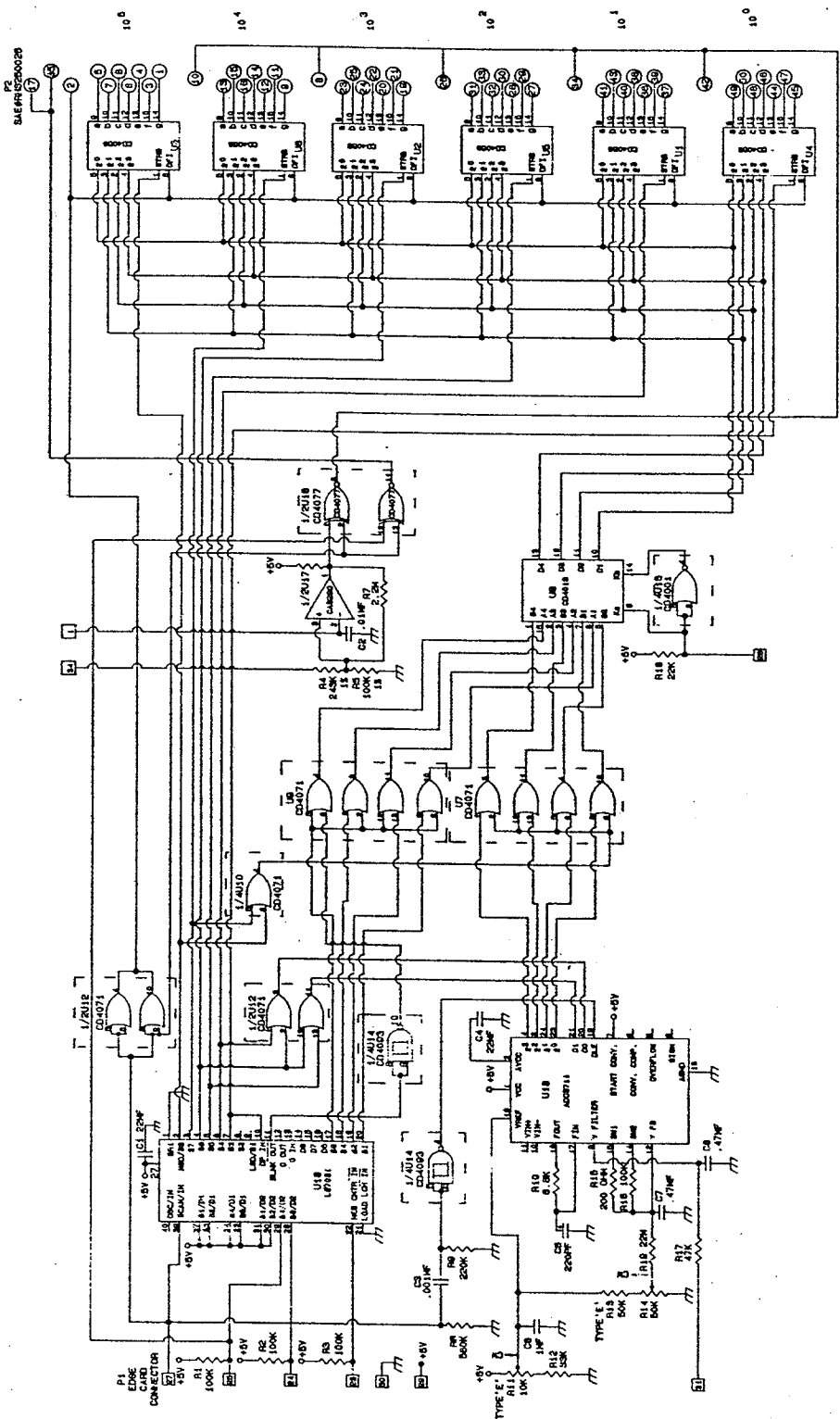

CHK NO.		DNN	CHK	APP
DNN DATE	1/12/87	CHK	DATE	
BSS		APP	DATE	
TOL:	SHOP 970	SCALE:	PULSE	
	OTHER		OTHER	
TITLE	M2220			
LUDLUM MEASUREMENTS, INC. SERIES SHEET				
SHEET 261				
RC				

MODEL 2220 COUNTER BOARD 261x06

SCHEMATIC 261x06

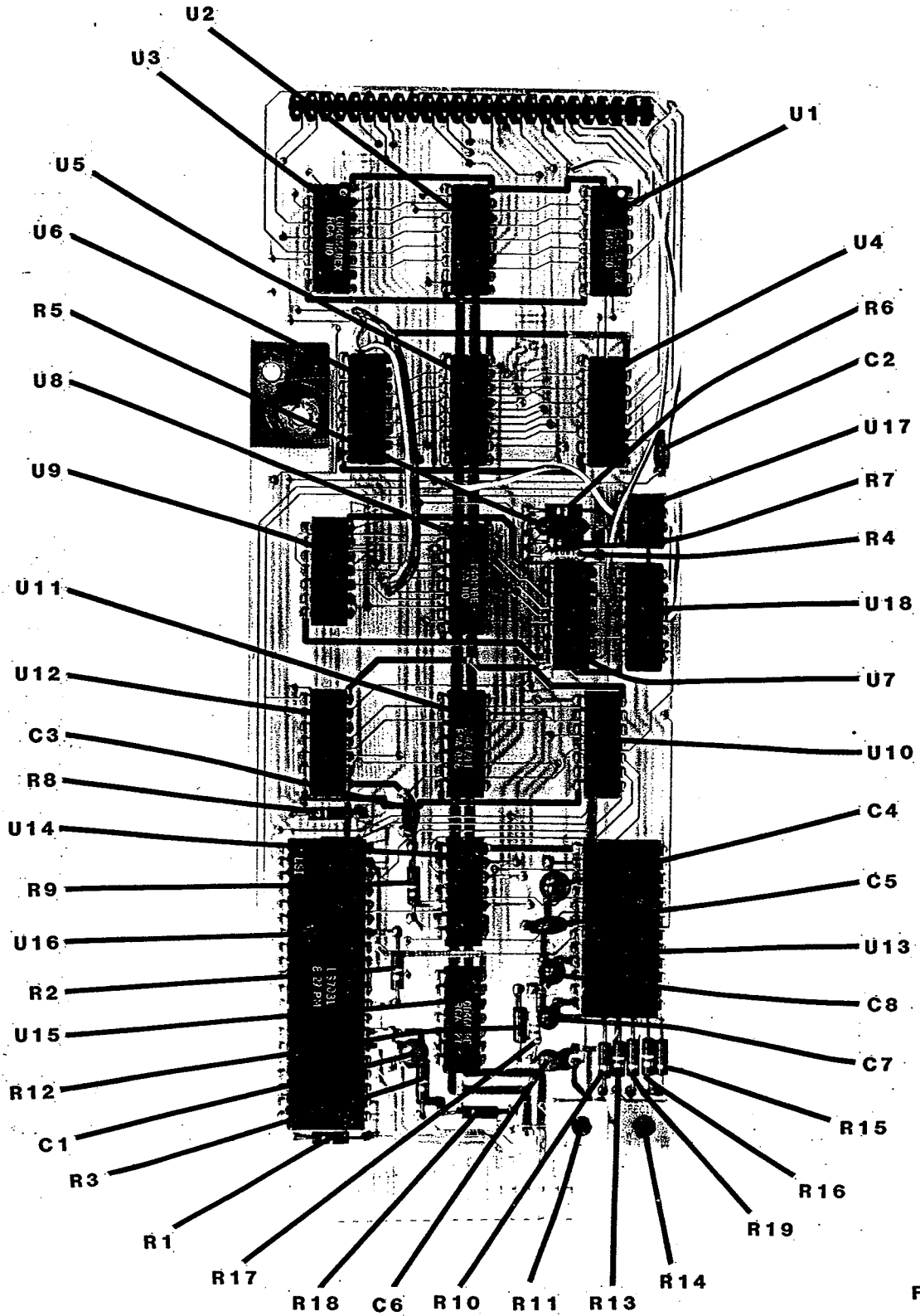
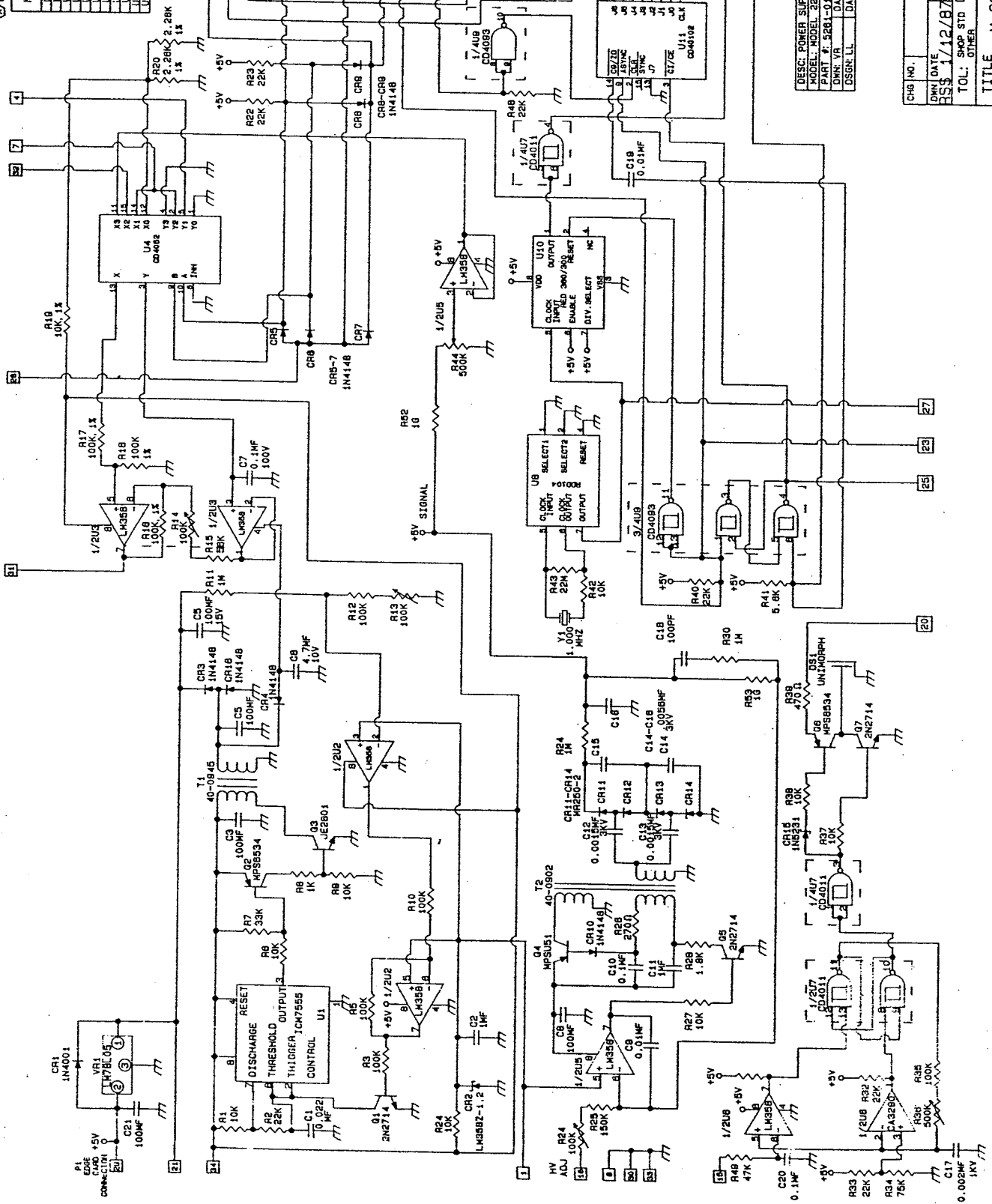

FIG.A

P1: EDGE CAPD CONNECTOR
 P2: DIP CONNECTOR

NO.	DEVICE	POWER CONNECTIONS
U1	LM355	1 5V GND
U2	LM355	1 5V GND
U3	LM355	1 5V GND
U4	CD4082	1 5V GND
U5	LM355	1 5V GND
U6	LM355	1 5V GND
U7	LM355	1 5V GND
U8	LM355	1 5V GND
U9	CD4082	1 5V GND
U10	REC380/300	1 5V GND
U11	CD40102	1 5V GND



DESC: POWER SUPPLY/CLOCK/AUDIO
 MODEL: MODEL 2220 (ARGONNET)
 PART # 3281-018
 DWA: VL DATE: 1/8/84
 DSGR: LL DATE: 11/81

CHG NO.	DWN	CHK	APP
DWG DATE	CHK DATE	APP DATE	
REV	7/12/87		
TOL:	SHOP STD	SCALE:	FULL
	OTHER		OTHER
TITLE M. 2220			
LUOLUM MEASUREMENTS, INC. SERIES 261			
SHEET 16C			

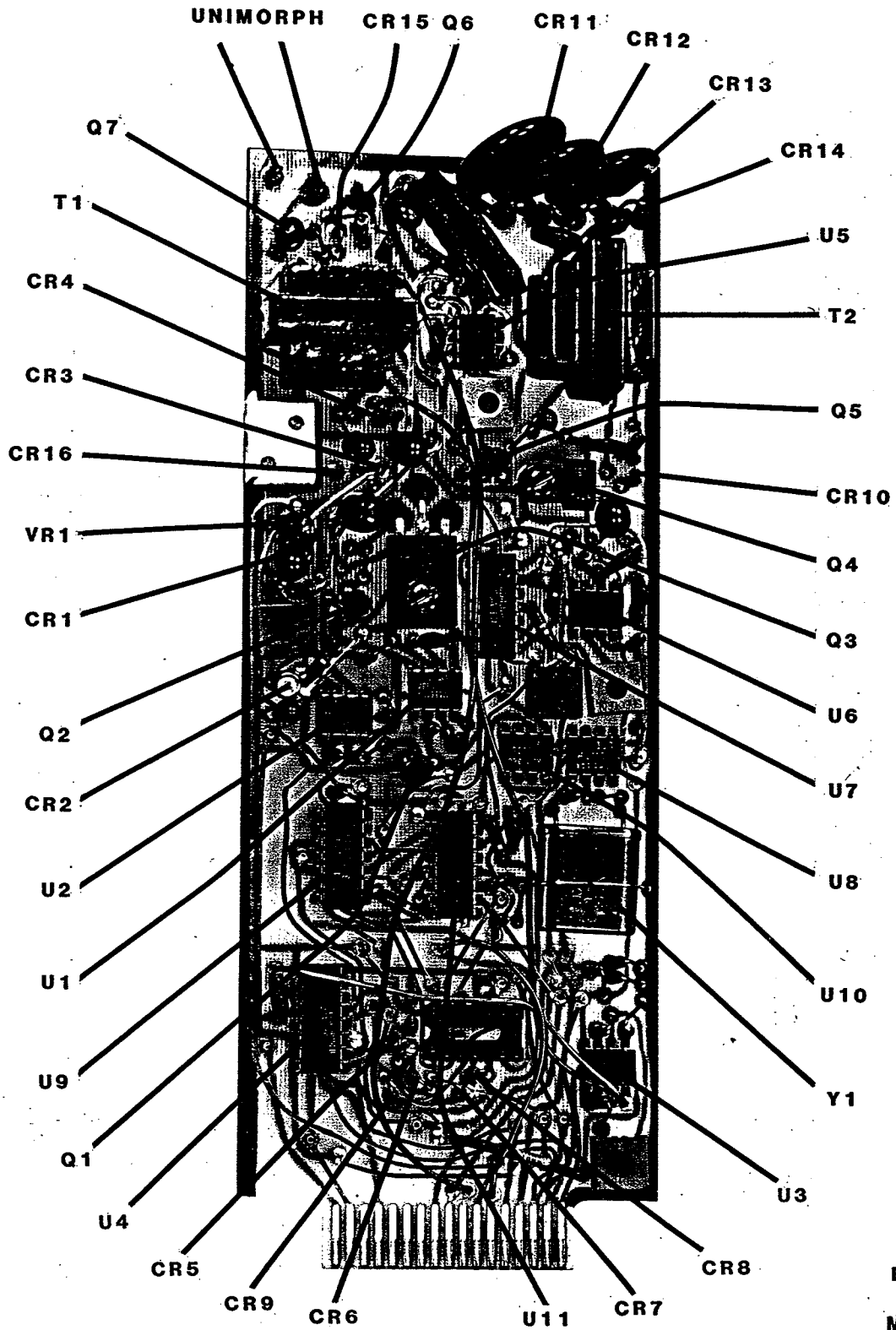

FIG.E

MISC.

COMPONENTS

MODEL 2220 POWER SUPPLY/CLOCK BOARD 261x16

SCHEMATIC 261x16

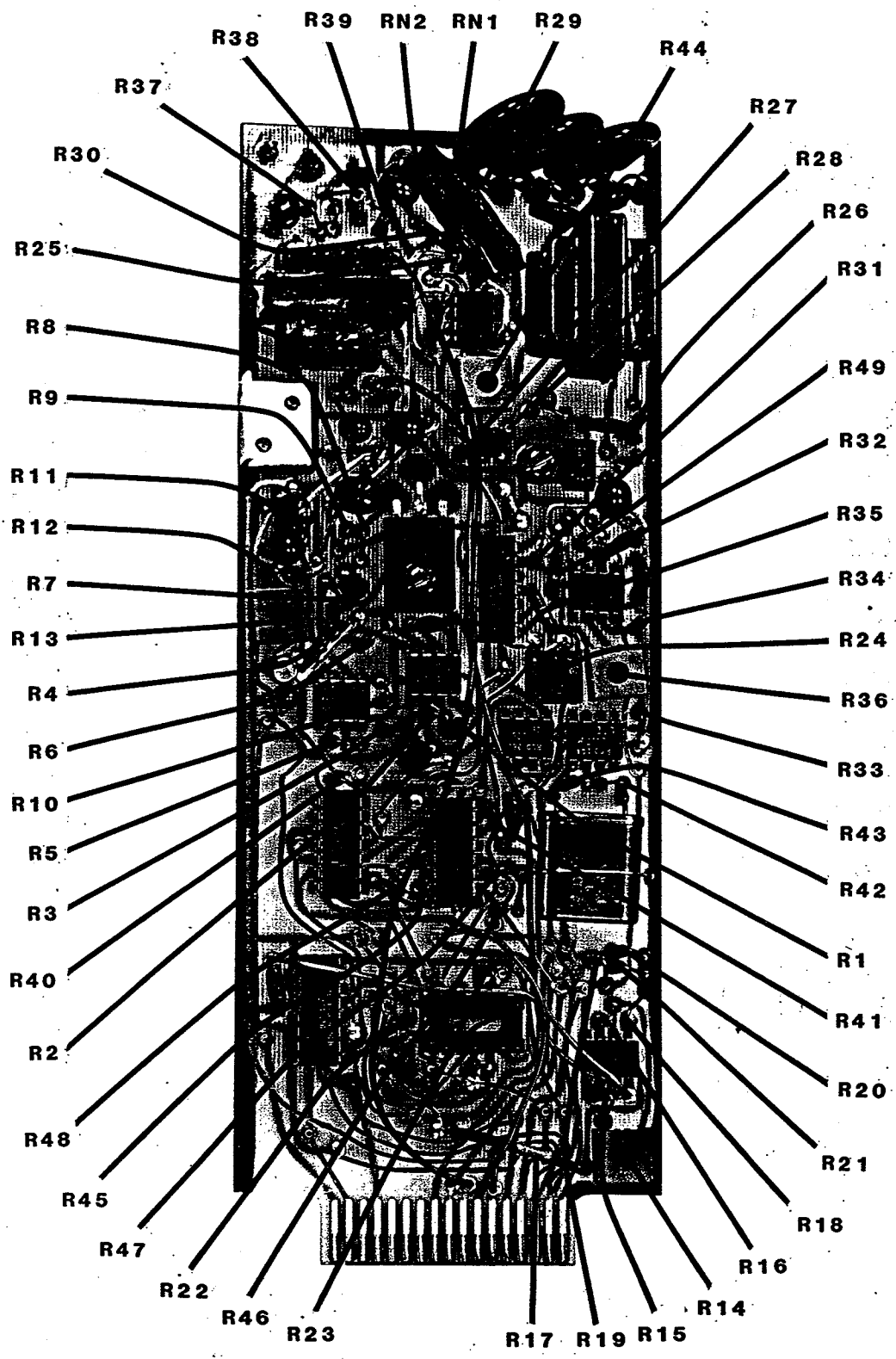

FIG.F

MODEL 2220 POWER SUPPLY/CLOCK BOARD 261x16 RESISTORS
 SCHEMATIC 261x16

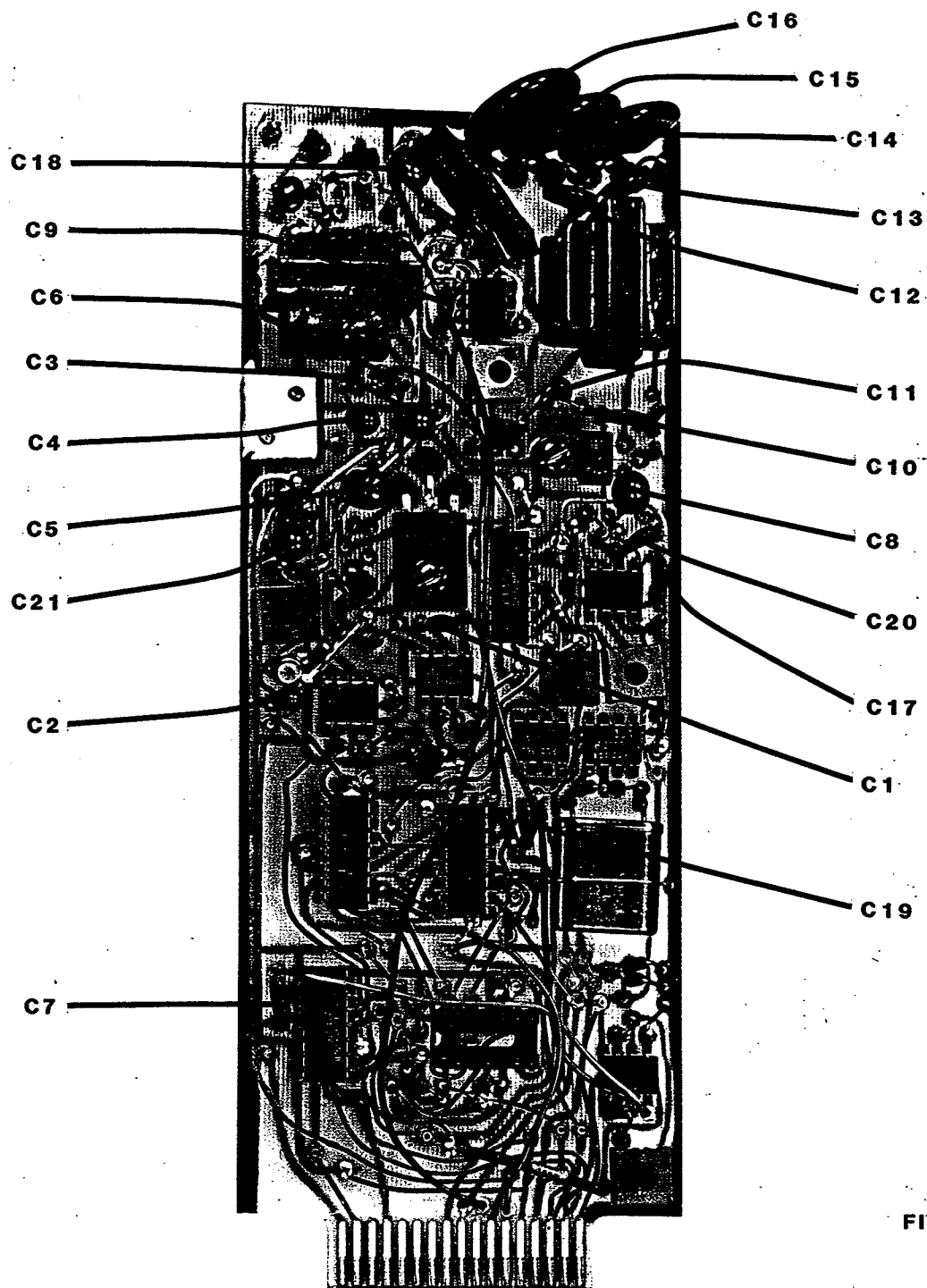
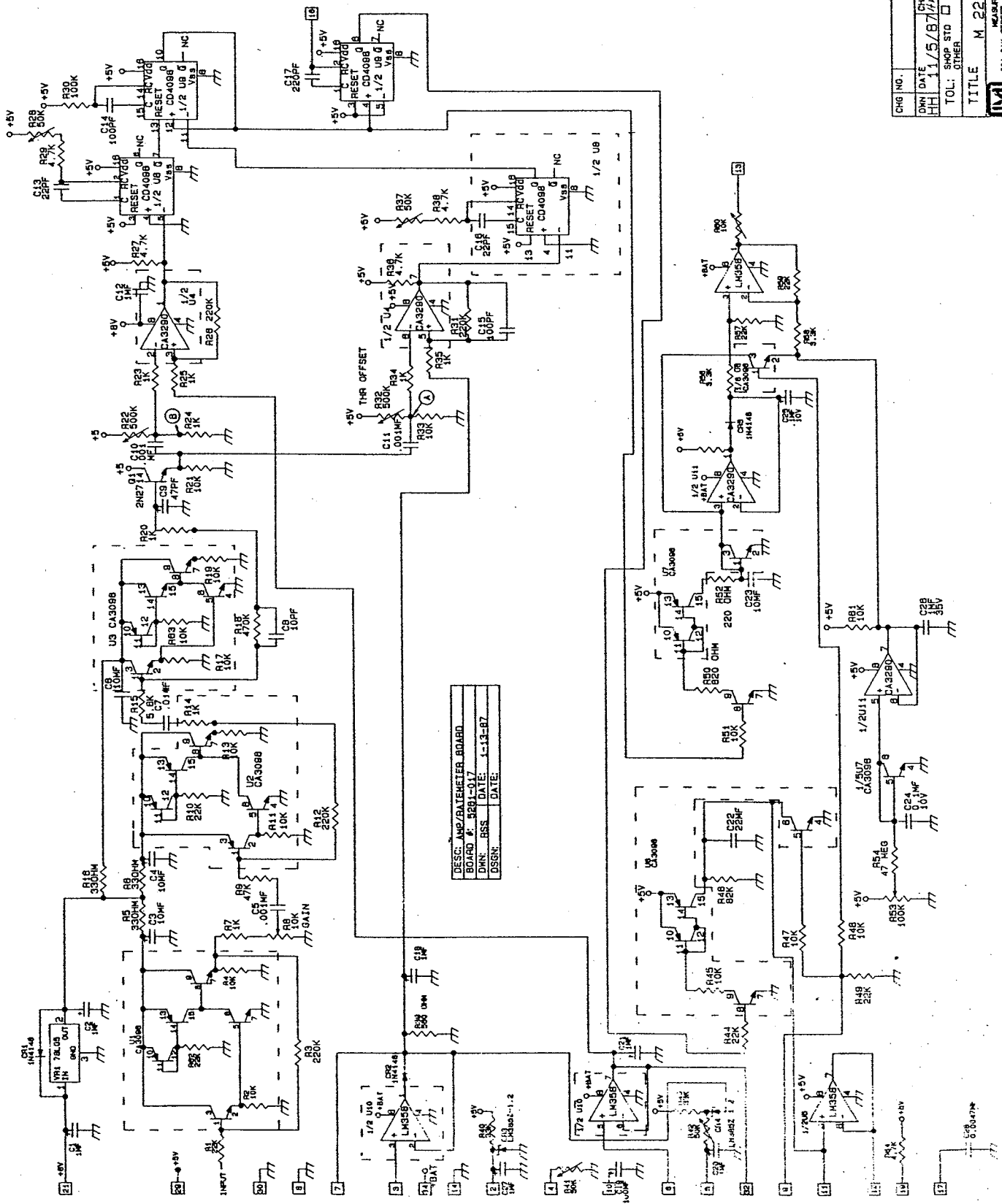

FIG.G

CAPACITORS

MODEL 2220 POWER SUPPLY/CLOCK BOARD 261x16

SCHEMATIC 261x16



DESC: ANAL/DIGITIZER BOARD
 BOARD #: 5281-017
 DWN: ISS DATE: 1-12-87
 DSSN: DATE:

CHG NO.	DWN	CHK	APP
DWN DATE	CHK DATE	APP DATE	
11/5/87	11/7/87		
TOL: SHOP STD	SCALE: FULL	OTHER	
TITLE: M 2220			
			SHEET 17C
501 DAK STREET SHERMANTON, TEXAS 75688			261

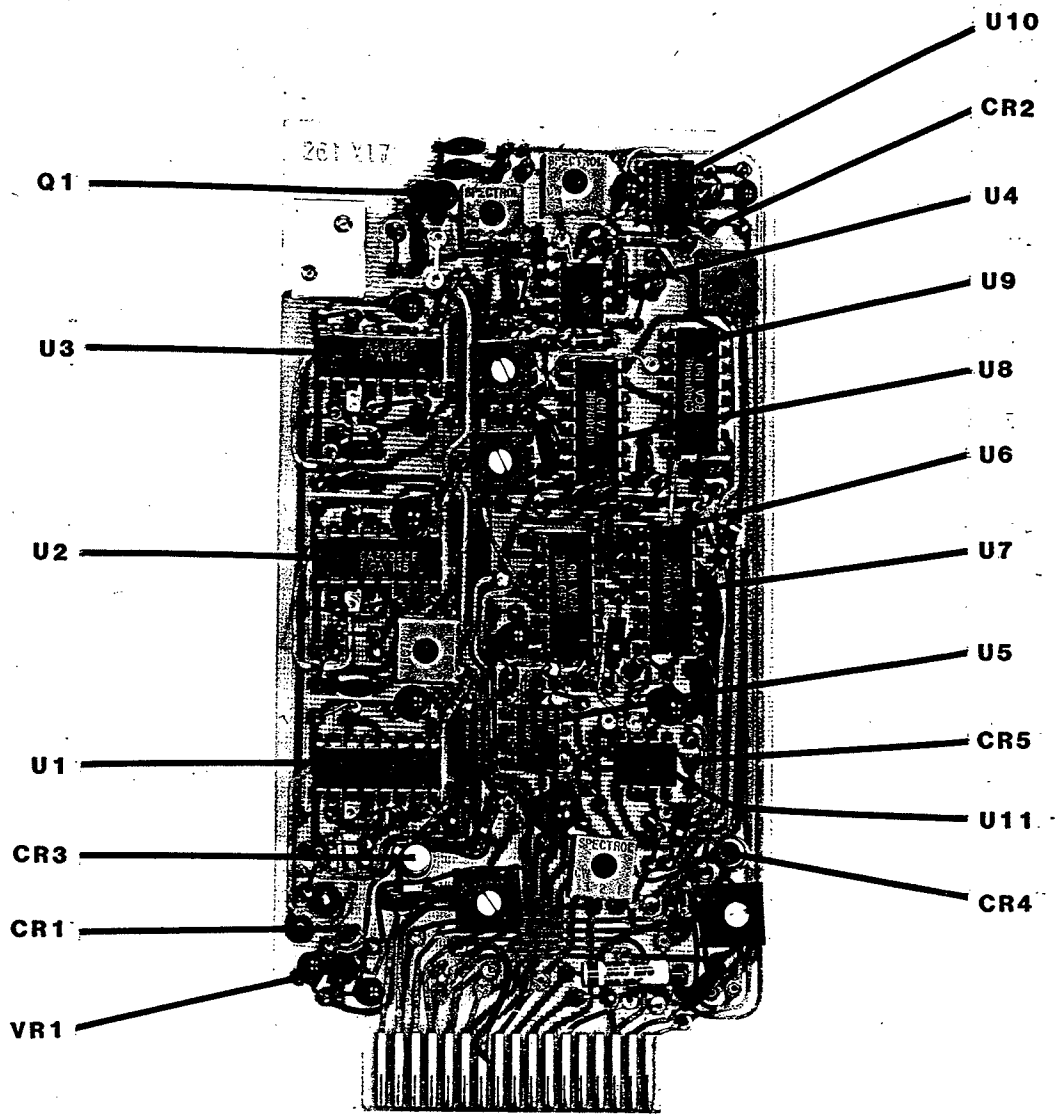

MODEL 2220 AMP/RATEMETER BOARD 261x17

SCHEMATIC 261x17

FIG.B

MISC. COMPONENTS

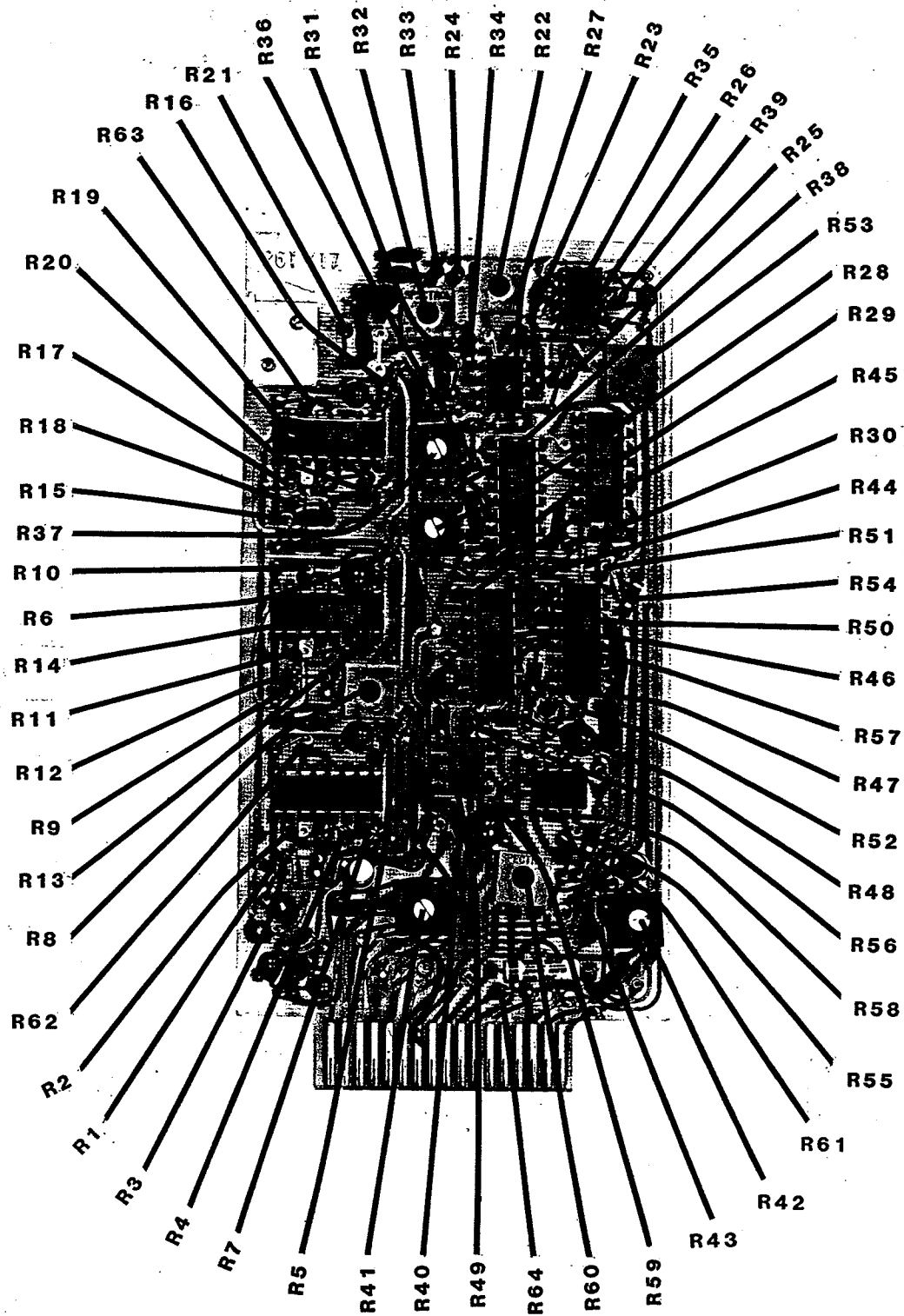

FIG.C

RESISTORS

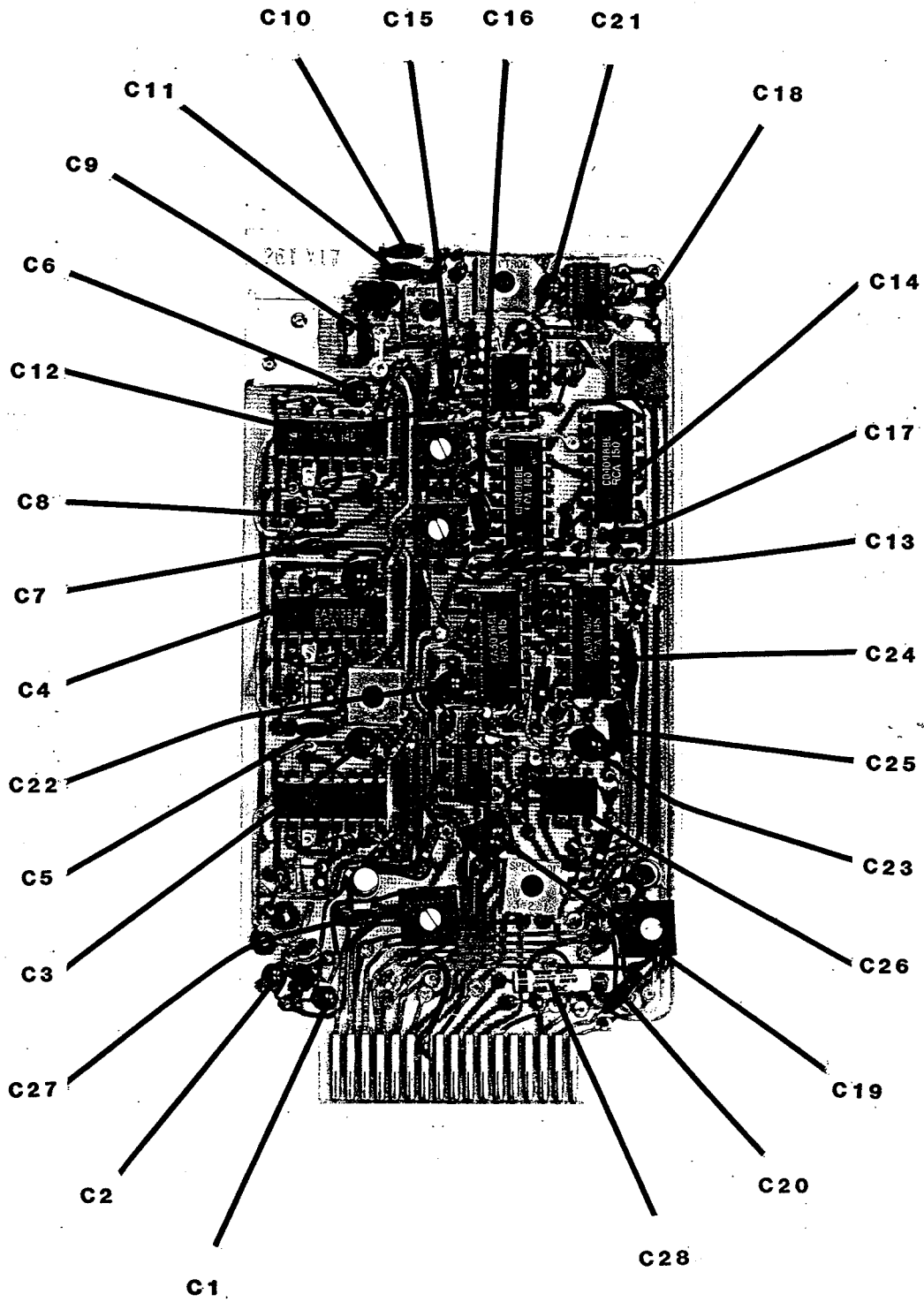

FIG.D

CAPACITORS

MODEL 2220 AMP/RATEMETER BOARD 261x17
 SCHEMATIC 261x17

COUNTER DISPLAY BOARD
5281-008 5281-014

POWER AMP/ COUNTER SUPPLY RATEMETER BOARD
5281-018 5281-017 5281-008

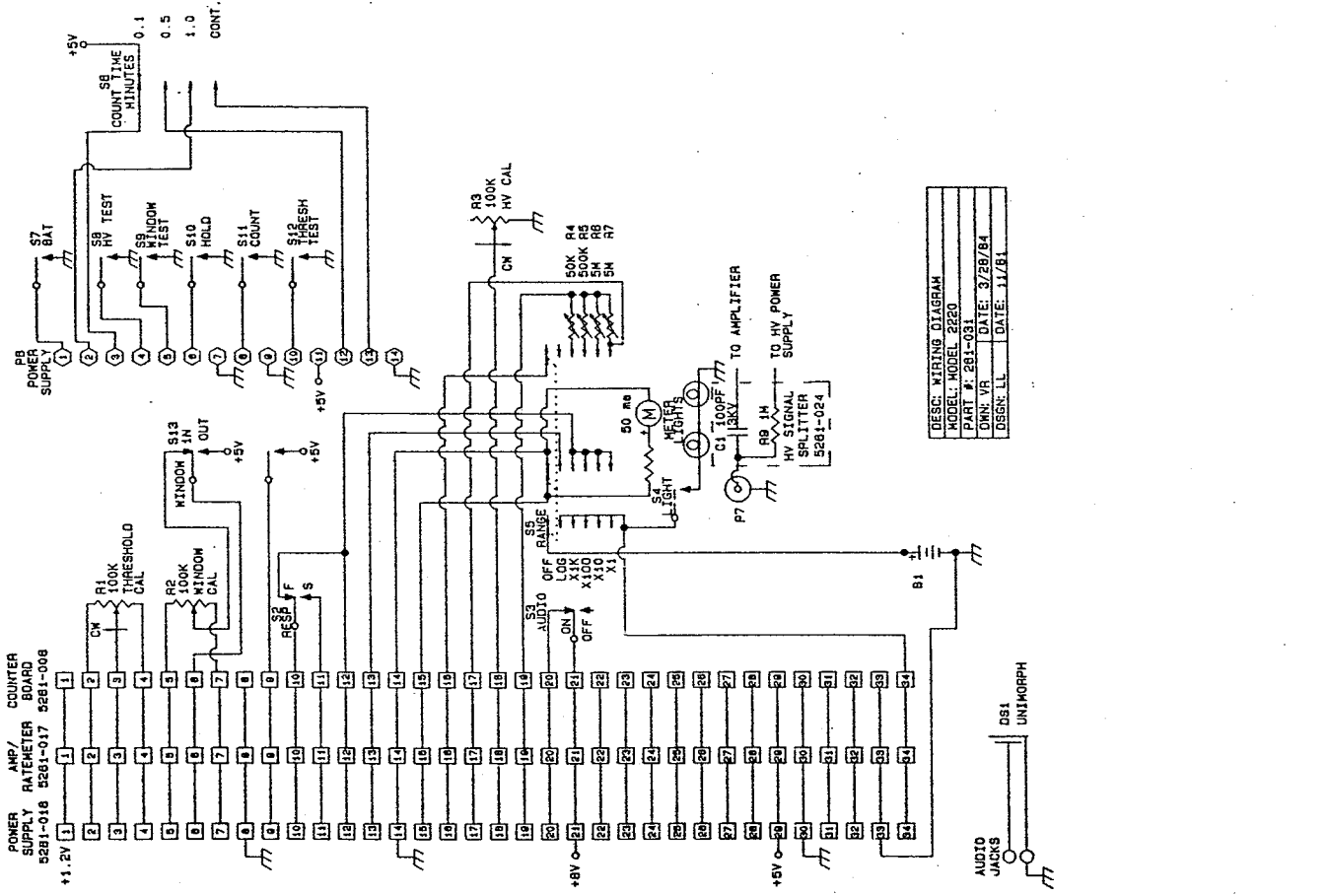

DESC: WIRING DIAGRAM
MODEL: MODEL 2220
PART #: 281-031
DMR: VR DATE: 3/28/84
DSGN: LL DATE: 11/81

CHK NO.	OWN	CHK	APP
DATE: 1/9/87	DATE: 1/9/87	DATE: 1/9/87	DATE: 1/9/87
TOL: STOP STD	SCALE: FULL	OTHER: <input type="checkbox"/>	
TITLE: M2220			
LUDLUM MEASUREMENTS, INC., SERIES 281			SHEET 310

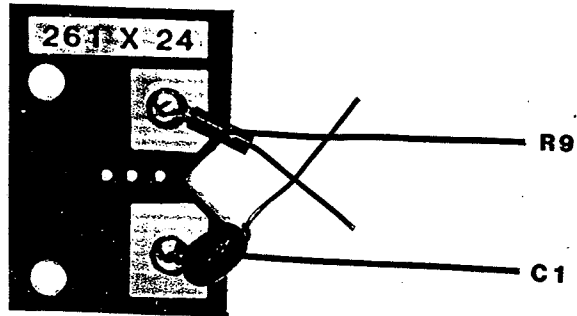

MODEL 2220 HV/SIG SPLITTER BOARD 261x24

SCHEMATIC 261x31

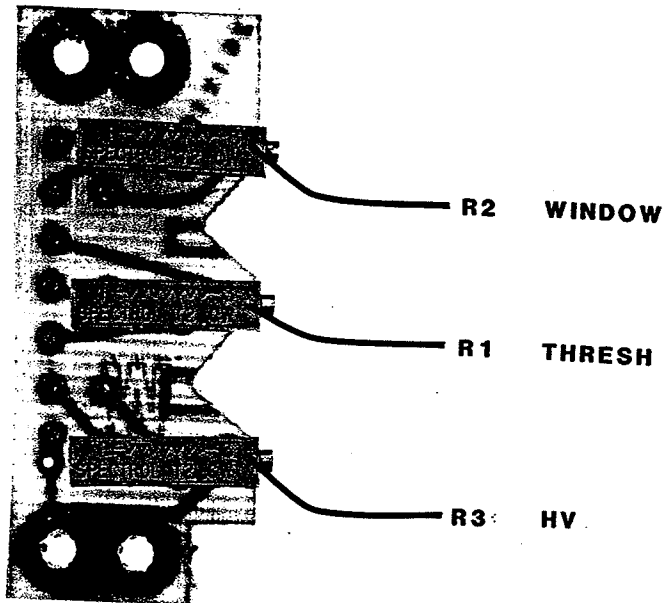

MODEL 2220 POT BOARD 261x19

SCHEMATIC 261x31

FIG.H

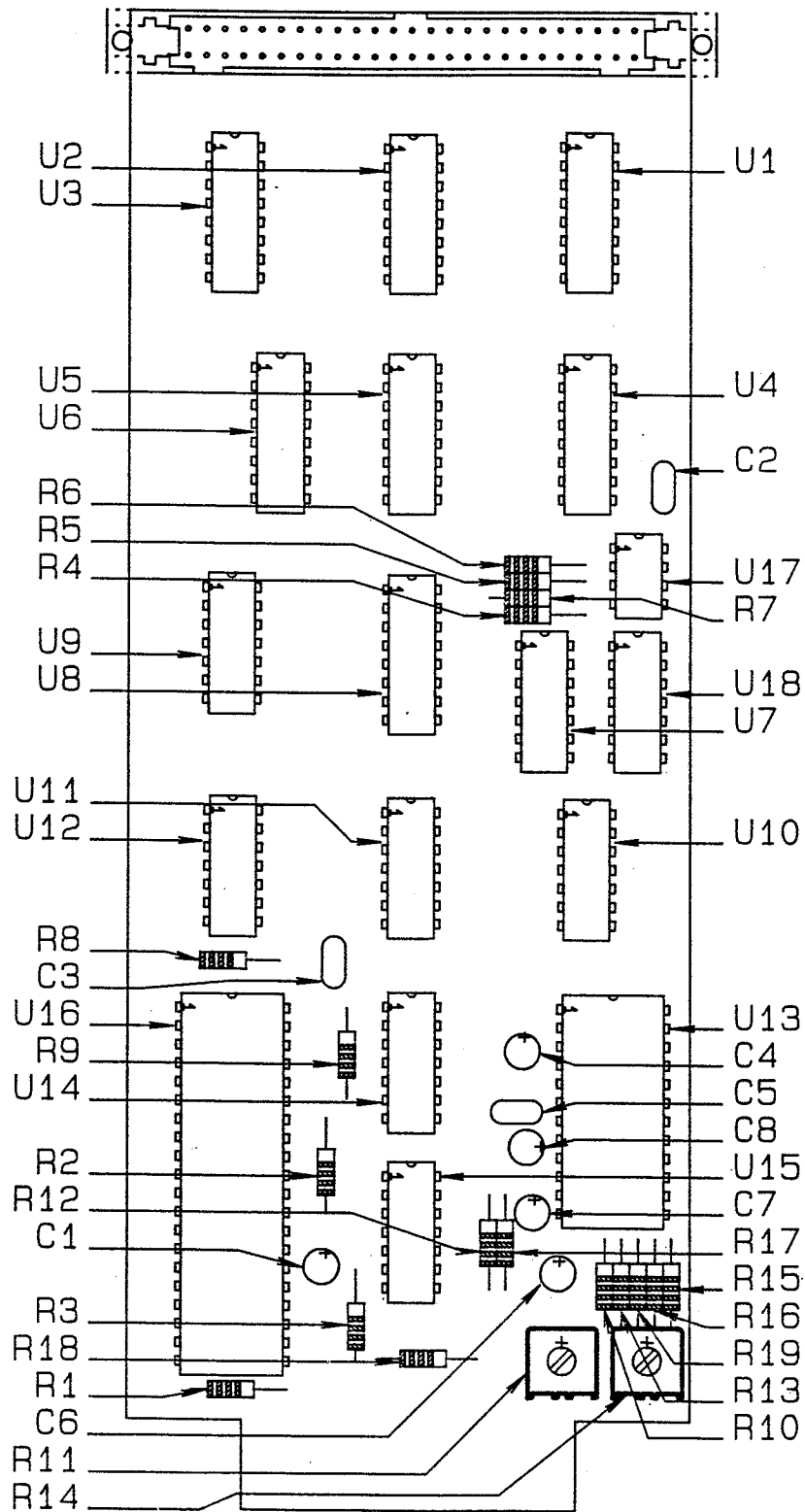

DESC: MODEL 2220 COUNTER BOARD	
BOARD #: 5261-006	
DWN: HH	DATE: 2/18/87
DSGN:	DATE:

CHG NO.		DWN	CHK	APP
DWN DATE	HH 2/18/87	CHK DATE		APP DATE
TOL: SHOP STD	<input type="checkbox"/>	SCALE: FULL	<input type="checkbox"/>	
OTHER		OTHER		
TITLE MODEL 2220 COUNTER BOARD				
M LUQUON MEASUREMENTS, INC.	SERIES	SHEET		
504 OAK STREET SWEETWATER, TEXAS 75086	261	46		

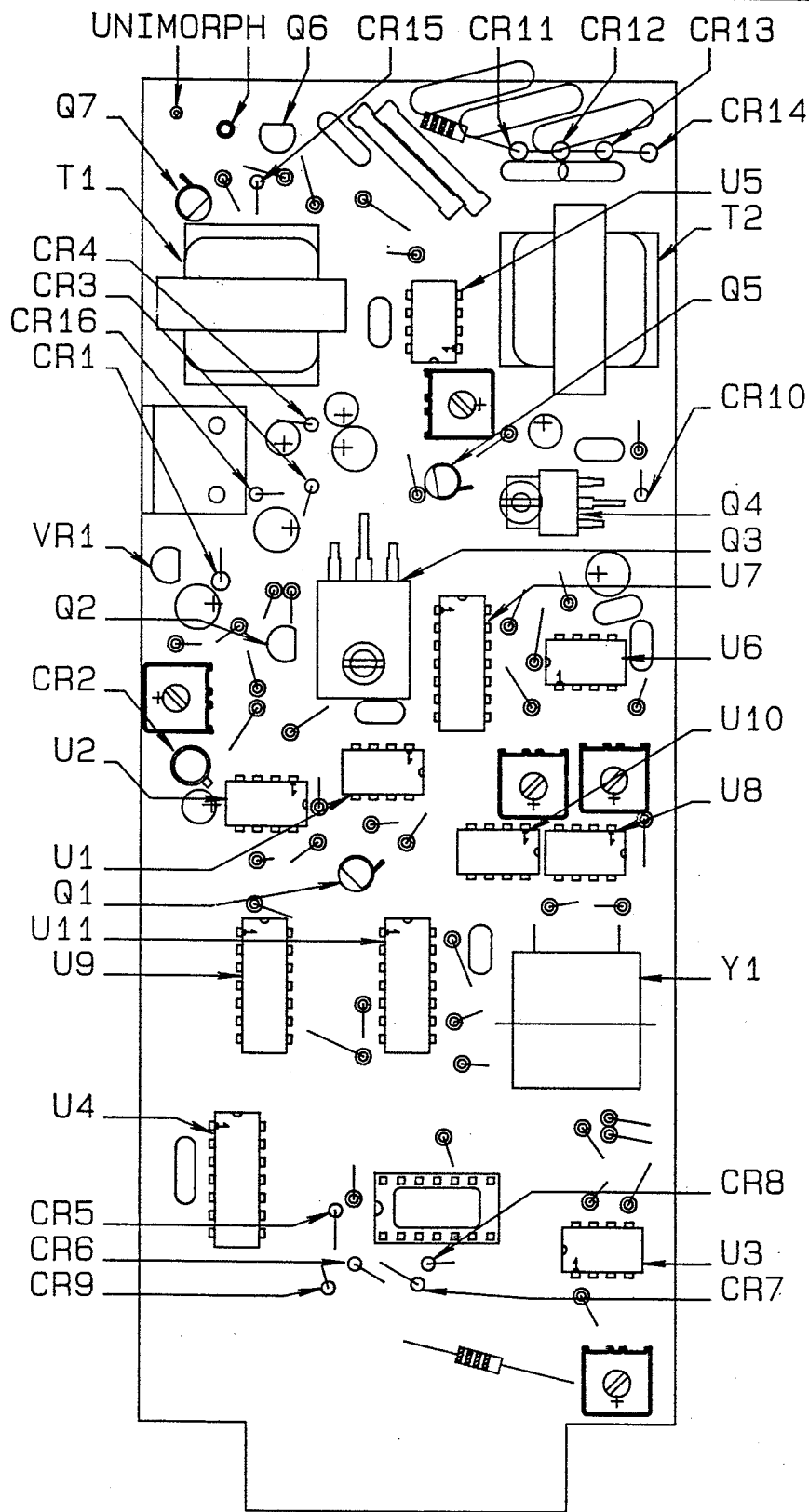

DESC: MODEL 2220 P.S./CLOCK BRD	
BOARD #: 5261-016	
DWN: HH	DATE: 2/20/87
DSGN:	DATE:

CHG NO.	DWN	CHK	APP
DWN DATE HH 2/20/87	CHK DATE HH	APP DATE HH	
TOL: SHOP STD <input type="checkbox"/>	SCALE: FULL <input type="checkbox"/>		
OTHER	OTHER		
TITLE MODEL 2220 P.S./CLOCK BOARD			
M LUCIUM MEASUREMENTS, INC. 501 OAK STREET SWEETWATER, TEXAS 75086	SERIES 261	SHEET 47A	

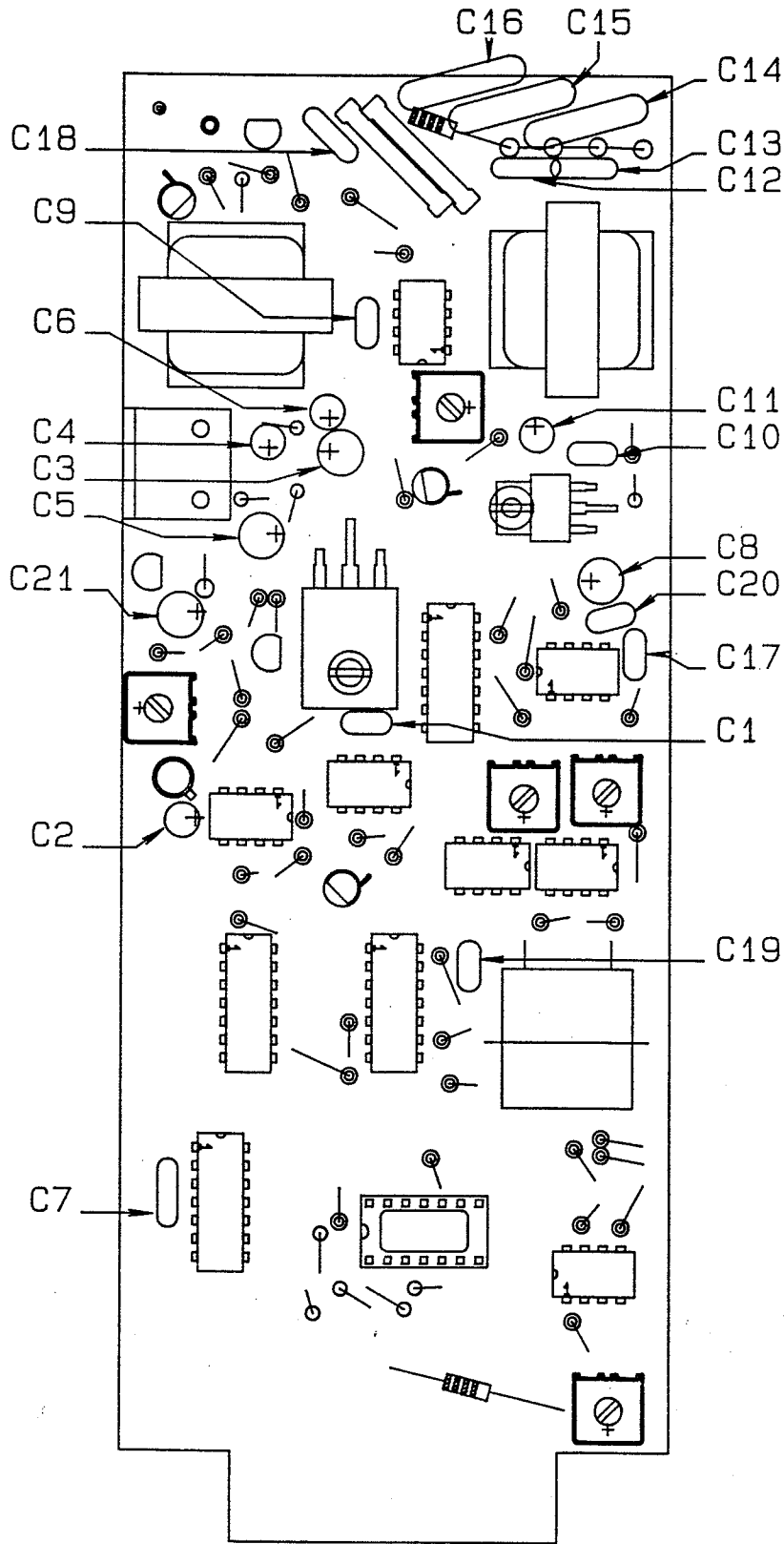

DESC: MODEL 2220 P.S./CLOCK BRD	
BOARD #: 5261-016	
DWN: HH	DATE: 2/20/87
DSGN:	DATE:

CHG NO.		DWN	CHK	APP	
DWN	DATE	CHK	DATE	APP	DATE
HH	2/20/87				
TOL: SHOP STD <input type="checkbox"/>			SCALE: FULL <input type="checkbox"/>		
OTHER			OTHER		
TITLE MODEL 2220 P.S./CLOCK BOARD					
LUDLUM MEASUREMENTS, INC. 304 OAK STREET SWEETWATER, TEXAS 75066		SERIES	SHEET		
		261	47B		

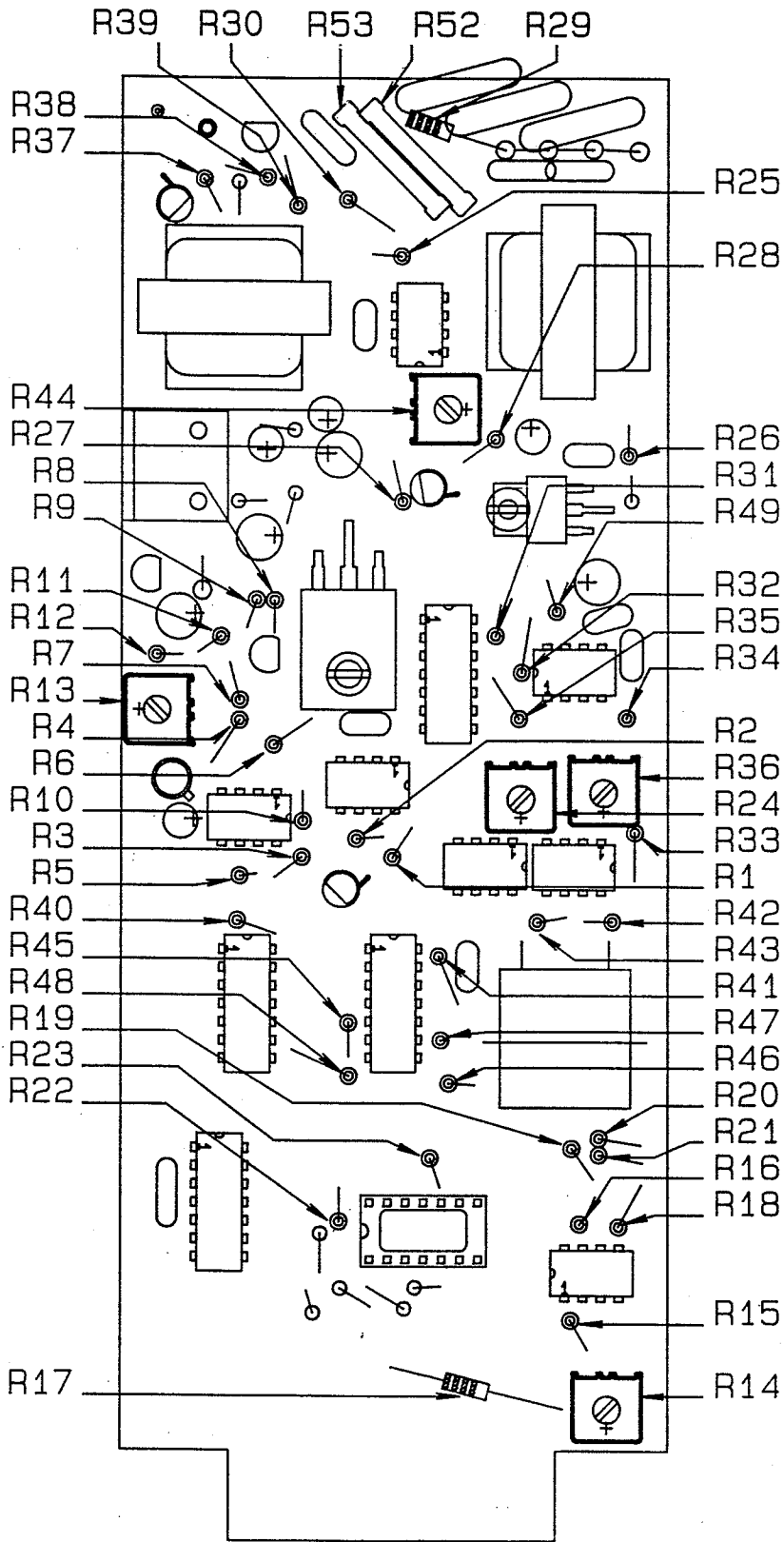

DESC: MODEL 2220 P.S./CLOCK BRD	
BOARD #: 5261-016	
DWN: HH	DATE: 2/20/87
DSGN:	DATE:

CHG NO.		DWN	CHK	APP
DWN DATE	HH 2/20/87	CHK DATE		APP DATE
TOL: SHOP STD	<input type="checkbox"/>	SCALE: FULL	<input type="checkbox"/>	OTHER
TITLE MODEL 2220 P.S./CLOCK BOARD				
	LUDLUM MEASUREMENTS, INC.	SERIES	SHEET	
	504 DAK STREET SWEETWATER, TEXAS 76086	261	470	

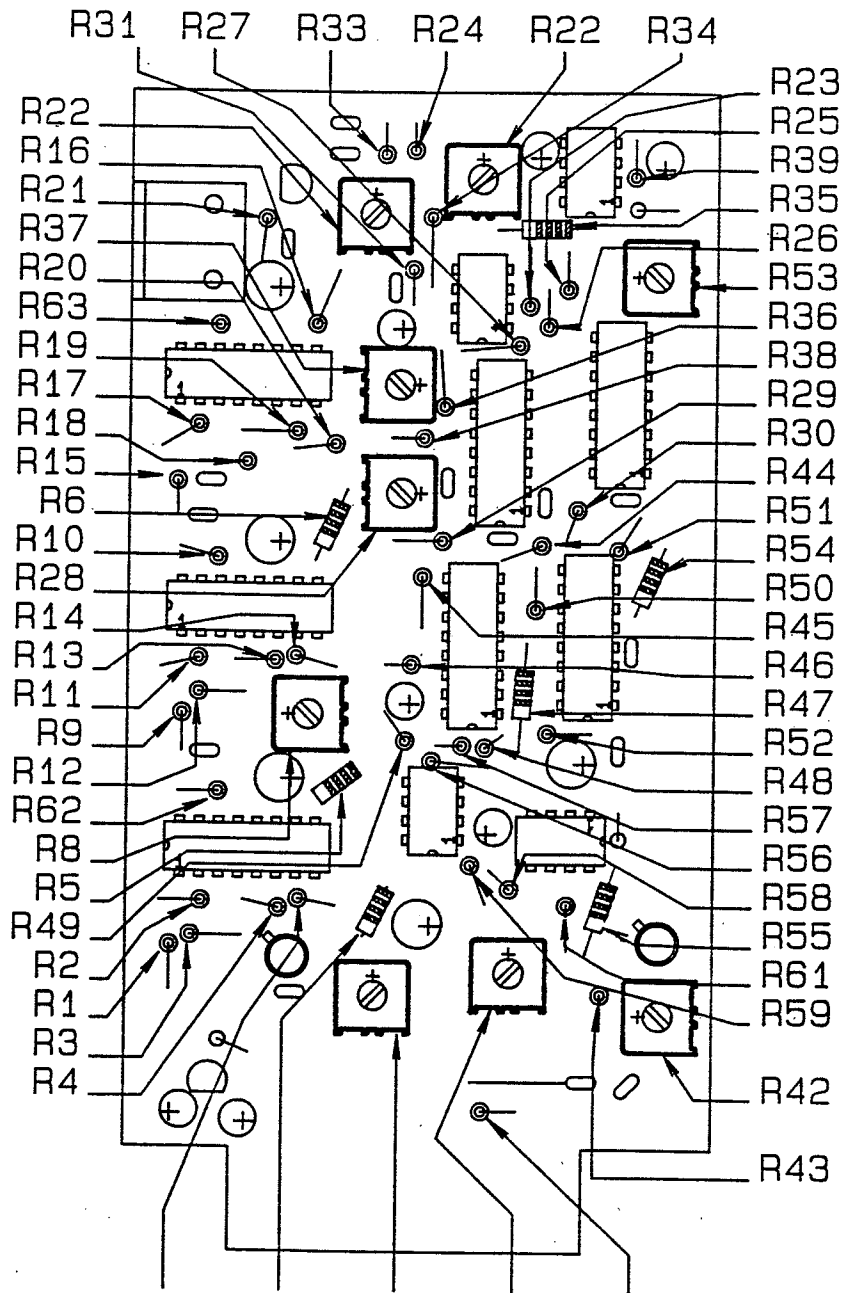

DESC: M 2220 AMP/RATEMTR BOARD	
BOARD #: 5261-017	
DWN: HH	DATE: 2/21/87
DSGN:	DATE:

CHK NO.	DWN CHK APP	
DRN DATE HH/2/25/87	CHK DATE	APP DATE
TOL: SHOP STD <input type="checkbox"/>	SCALE: FULL <input type="checkbox"/>	
OTHER	OTHER	
TITLE MODEL 2220 AMP/RATEMTR BRD		
LUDLUM MEASUREMENTS, INC.	SERIES	SHEET
308 GAK STREET SPECTRATOR, TEXAS 76088	261	48A

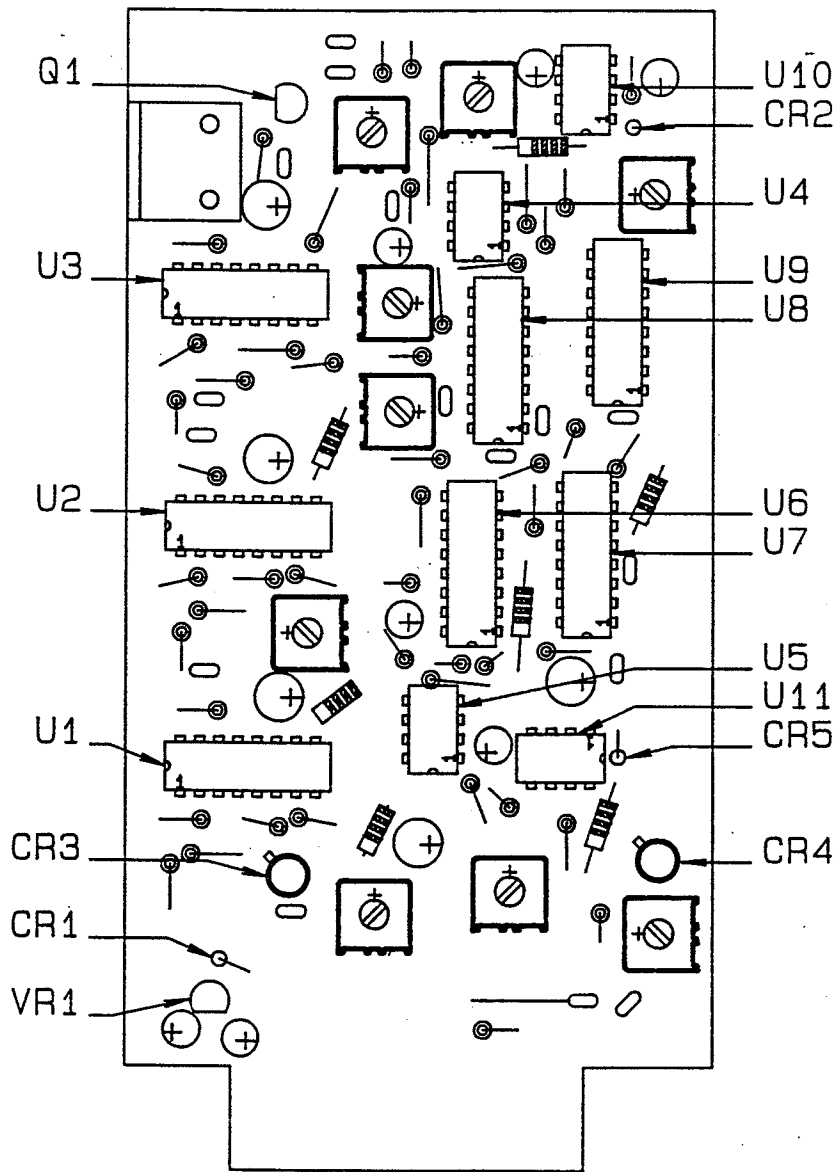

DESC: M 2220 AMP/RATEMTR BOARD	
BOARD #: 5261-017	
DWN: HH	DATE: 2/21/87
DSGN:	DATE:

CHG NO.		DWN	CHK	APP
DWN DATE	CHK DATE	APP DATE		
HH/2/25/87				
TOL: SHIP STD <input type="checkbox"/>	SCALE: FULL <input type="checkbox"/>			
OTHER	OTHER			
TITLE MODEL 2220 AMP/RATEMTR BRD				
LUDLUM MEASUREMENTS, INC. SERIES				SHEET
704 CAK STREET				281
WEEHSTER, TEXAS 75086				488

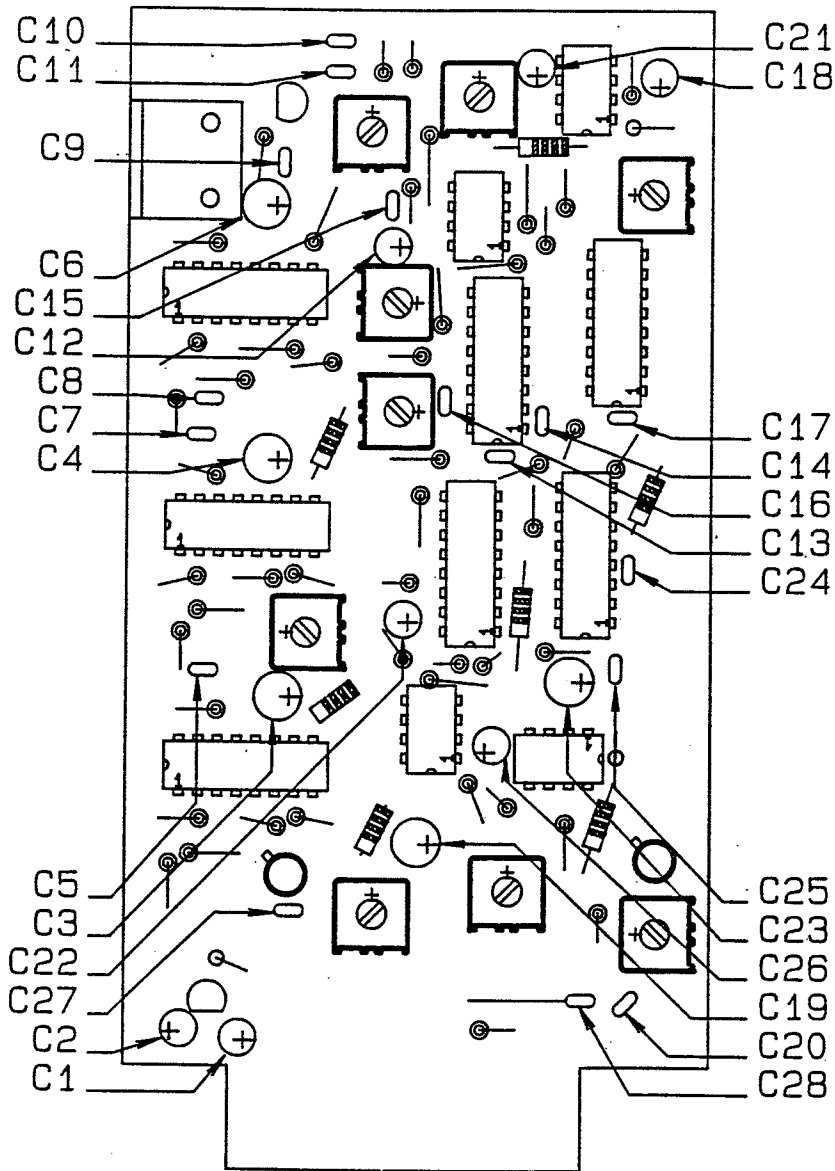

DESC: M 2220 AMP/RATEMTR BOARD	
BOARD #: 5261-017	
DWN: HH	DATE: 2/21/87
DSGN:	DATE:

CHG NO.		DRN	CHK	APP
DRN DATE	CHK DATE	APP DATE		
HH/2/25/87				
TOL: SHOP STD <input type="checkbox"/>	SCALE: FULL <input type="checkbox"/>			
OTHER	OTHER			
TITLE MODEL 2220 AMP/RATEMTR BRD				
LUDLUM MEASUREMENTS, INC.		SERIES	SHEET	
301 PAK STREET		261	48C	
DALLAS, TEXAS 75208				

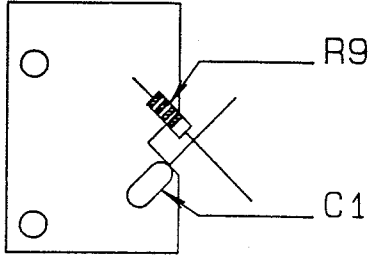

DESC: M2220 HV/SIG SPLITTER BRD	
BOARD #: 261-024	
DWN: HH	DATE: 2/25/87
DSGN:	DATE:

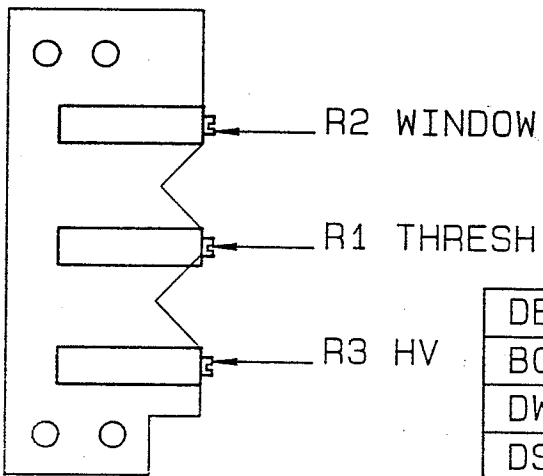

DESC: MODEL 2220 POT BOARD	
BOARD #: 261-019	
DWN: HH	DATE: 2/25/87
DSGN:	DATE:

CHG NO.		DWN	CHK	APP	
DWN	DATE	CHK	DATE	APP	DATE
HH	2/25/87				
TOL: SHOP STD <input type="checkbox"/>		SCALE: FULL <input type="checkbox"/>			
OTHER		OTHER			
TITLE M2220 HV/SIG SPLTR & POT BRD					
LUDLUM MEASUREMENTS, INC.		SERIES		SHEET	
504 OAK STREET		261		49	
SWEETWATER, TEXAS 75060					