

HSMM Radio Equipment

Readily available computer oriented Wi-Fi equipment can be used to form the basis for high speed data transport at 2.4 GHz and above. This article shows you how it's done and how it works.

By John Champa, K8OCL; and John B. Stephensen, KD6OZH;
With input from Dave Stubb, VA3BHF

Introduction

This is the first article to discuss what is known in Amateur Radio as High-Speed Multimedia (HSMM) radio in technical detail. HSMM Radio is a form of Amateur Packet Radio that starts at speeds of 56 kbps and goes up from there up to 5000 times faster than conventional packet radio. This capability enables multimedia, or simultaneous digital video, digital voice, data, and text. Initial HSMM Amateur Radio research has been based on readily available, inexpensive commercial gear designed for WiFi or wireless local area networking (WLAN). HSMM is not a specific mode—it is, instead, a direction or a driving force within Amateur Radio to develop high-speed digital networking capability under Part 97 regulations.

Military surplus radio equipment fueled Amateur Radio in the 1950s. Commercial FM radios and repeaters snowballed the popularity of VHF/UHF amateur repeaters in the 1960s and 70s. In the same way, current availability of commercial wireless

LAN (WLAN) equipment is driving the direction and popularity of Amateur Radio use of spread spectrum in the early 2000s.

The Institute of Electrical and Electronics Engineers (IEEE) has provided the standards under which manufacturers have developed WLAN equipment for sale commercially and hams have adapted this equipment to outdoor use. The IEEE 802.11 series of standards defines a series of RF modems similarly to the way that the International Telecommunications Union (ITU) defined a series of telephone modems in the past. The term “WiFi” is short for wireless fidelity and indicates that the subject equipment has been tested to ensure that it fully complies with the applicable IEEE 802.11 standard.

Accordingly, the first part of this article describes existing 802.11 equipment for the 13-cm and 5-cm amateur bands. The second part of this article describes a proposed communication protocol for HSMM operation that will fit into the existing ARRL

band plans from 219 to 2400 MHz. The initial implementation will make use of the DCP-1 hardware module described in an article by John Stephensen, KD6OZH.

Existing Products— High Speed Multimedia Radio

In early 2002 the ARRL Technology Task Force (TTF) established the High Speed Multimedia (HSMM) Working Group with John Champa, K8OCL, as its chairman. John moved quickly to identify two initial goals for the new working group to immediately begin the development of such high-speed digital Amateur Radio networks:

- Encourage the amateur adoption and modification of COTS IEEE 802.11 spread spectrum hardware and software for Part 97 uses.
- Encourage or develop other high-speed digital radio networking techniques, hardware, and applications.

These efforts were rapidly dubbed HSMM Radio. Although initially dependent on adaptation of COTS 802.11 gear to Part 97, the emphasis is on simultaneous voice, video, data, and text modes.

Applications

HSMM radio has some unique ham

2491 Itsell Rd
Howell, MI 48843-6458
k8ocl@arrl.net

3064 E Brown Ave
Fresno, CA 93703-1229
kd6ozh@verizon.net

radio networking applications and operational practices that differentiate it from normal WiFi hotspots at coffeehouses and airports as described in the popular press. HSMM radio techniques are often used for system RC (remote control) of Amateur Radio stations.

In this day of environmentally sensitive neighborhoods, one of the greatest challenges, particularly in high-density residential areas, is constructing ham radio antennas; particularly high tower-mounted HF beam antennas. Such amateur installations also represent a significant investment in time and resources. This burden could be easily shared among a small group of friendly hams, a radio club or a repeater group.

Implementing a link to a remote HF station via HSMM radio is easy to do. Most computers now come with built-in multimedia support. Most Amateur Radio transceivers are capable of PC control. Adding the radio networking is relatively simple. Most HSMM radio links use small 2.4 GHz antennas mounted outdoors or pointed through a window. These UHF antennas are relatively small and inconspicuous when compared to a full-size 3-element HF Yagi on a tall steel tower.

A ham does not have to have an antenna-unfriendly homeowners association or a specific deed restriction problem to put RC via HSMM radio to good use. This system RC concept could be extended to other types of Amateur Radio stations. For example, it could be used to link a ham's home to a shared high performance Amateur Radio DX station, EME station, or OSCAR satellite ground station for a special event or even on a regular basis.

Shared Internet Access

Sharing high-speed Internet access (Cable, DSL, etc.) with another ham is a popular application for HSMM radio. As long as it is not done for profit, it is entirely legal in the US under Part 97

rules. However be careful to read the terms of service supplied by your service provider. Many have restrictions against sharing your service with another party. If you violate the terms and conditions of your service agreement, the provider can (and will) disconnect your service. Pop-up ads, although a nuisance, are not illegal and can readily be controlled by the proper browser configuration. Just as on the Internet, it is possible to do such things as playing interactive games, complete with sound effects and full motion animation, with HSMM radio. This can be lots of fun for new and old hams alike, plus it can attract others in the "Internet Generation" to get interested in Amateur

Radio and perhaps become new radio club members. In the commercial world these activities are called "WLAN Parties". Such e-games are also an excellent method for testing HSMM radio link speed.

Emergency Communications

There are a number of significant reasons why HSMM radio is the wave of the future for many Emergency Communications Support (RACES, ARES, etc.) situations.

- The amount of digital radio traffic on 2.4 GHz is increasing and operating under low powered, unlicensed Part 15 limitations cannot overcome this noise.

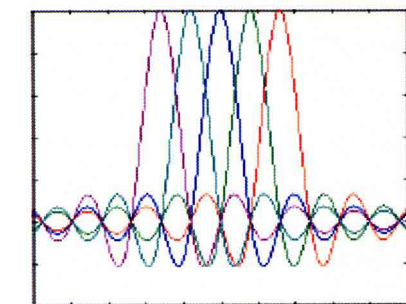
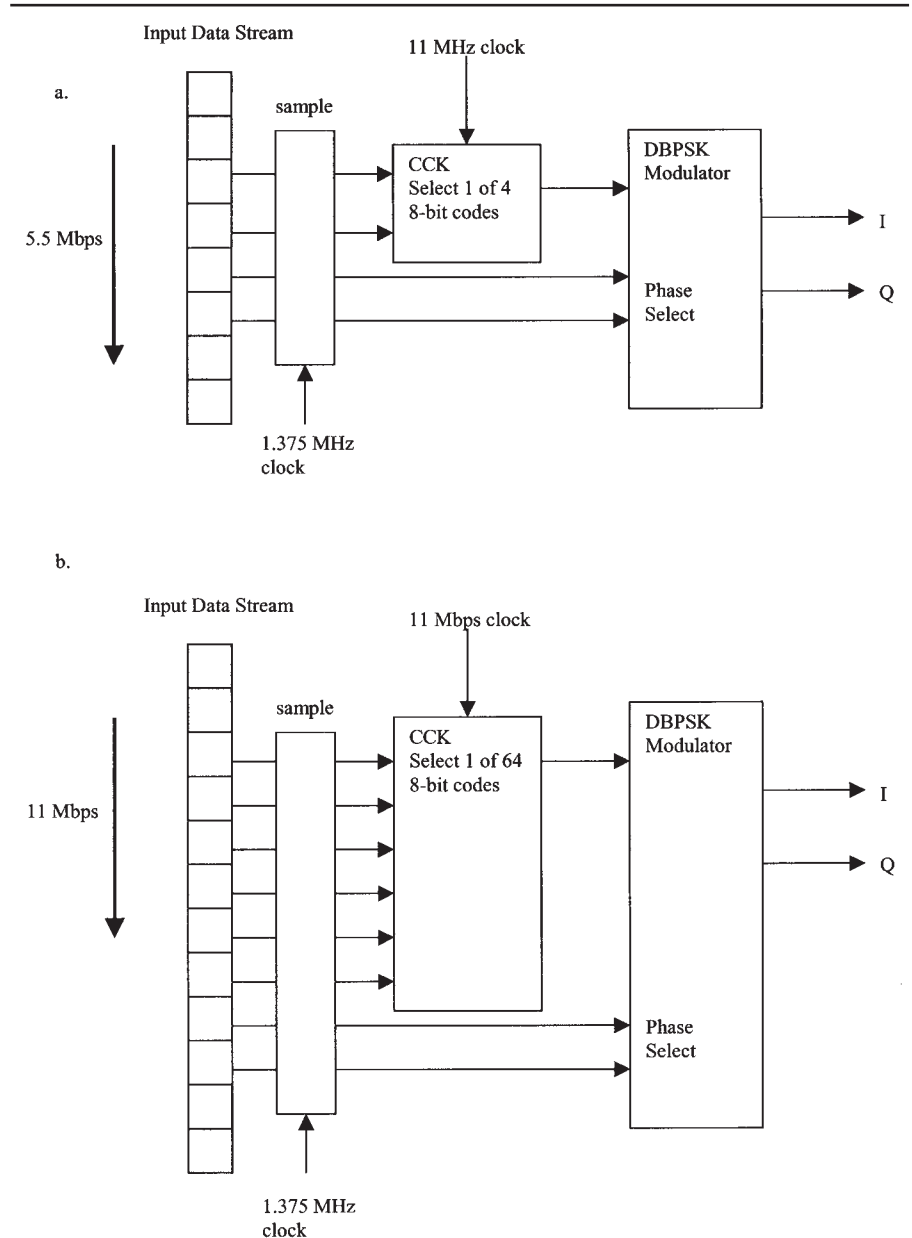

Fig 1—OFDM carrier interleaving.

Fig 2—Encoding complementary code frequency sequence.

- EmComm organizations increasingly need high-speed radio networks that can get out of the disaster area and into an area where ADSL, cable modem, satellite or other broadband Internet access is available.

With HSMM radio often all that would be needed to accomplish this in the field is a laptop computer with a headset, and perhaps an attached digital camera. The laptop must be equipped with a special wireless local area network card (PCMCIA) with an external antenna jack. In HSMM radio jargon such a card is simply called a RIC (radio interface card). Then connect the RIC to a short Yagi antenna (typically 18 inches of antenna boom length), or perhaps a small dish antenna mounted on a tripod weighted with a sandbag. Connection is established by pointing the antenna toward the HSMM repeater back at the EOC. More details are provided further into this paper.

Radio Relay for the 21st Century

There are a number of ways to extend the HSMM link. The most obvious means would appear to be to run higher power and place the antennas as high as possible, as is the case with VHF/UHF FM repeaters. In some densely populated urban areas of the country this approach with 802.11, at least in the 2.4 GHz band, may cause some interference with other users. Other means of getting greater distances using 802.11 on 2.4 GHz or other amateur bands should be considered. One approach is to use highly directive, high-gain antennas, or what is called the directive link approach. Another method used by some HSMM radio networks is what is called a low-profile radio network design. It depends on several low power sources and radio relays of various types. For example, two HSMM radio repeaters (known commercially as access points, or APs, about \$100 devices) may be placed back-to-back in what is known as bridge mode. In this configuration they will simply act as an automatic radio relay for the high-speed data. It is possible to cover greater distances with relatively low power and yet still move lots of multimedia data.

A Basic HSMM Radio Station

How does one set up an HSMM radio base station? It is really very easy. HSMM radio amateurs will just need to go to any electronics outlet or office supply store and buy commercial off-the-shelf (COTS) Wireless LAN gear, either IEEE 802.11b or IEEE 802.11g. They then connect external outdoor

antennas. That is all there is to it.

There are some purchasing guidelines to follow. First, decide what interfaces you are going to need to connect to your computer. Equipment is available for all standard computer interfaces: Ethernet, USB, and PCMCIA. If you use a laptop in your station, get the PCMCIA card. Make certain it is the type with an external antenna connection. If you have a PC, get the Wireless LAN adapter type that plugs into either the USB port or the RJ45 Ethernet port. Make certain it is the type that has a removable rubber duck antenna or external antenna port! Finally, compare the RF performance of the devices you are contemplating. Unfortunately, there is little performance consistency across brands. Better cards can be purchased with up to 200-mW power output and -97 dBm receive sensitivity. Poor performers (while useful for covering a room in a home or office) have power outputs of less than 30 mW and receive sensitivities in the mid-80s dBm range. Buying the best performing card you can afford will assure the best performance. Also make sure the hardware selected for both ends of the link have equivalent performance. The overall link will be limited by the worst performing device. The included directions will explain how to accomplish the installation of these devices in your computer or network. These devices have two operating modes: *ad-hoc* and *Infrastructure*. Infrastructure mode is used to communicate with an access point (AP—more on this later). Ad-hoc mode allows these client cards to communicate together, associate and form an “ad-hoc” network (thus the name). Setting two or more cards into ad-hoc mode is the easiest way to get started experimenting with HSMM.

These client devices are the core of any HSMM radio station. They become a computer-operated HSMM 2.4 GHz radio transceiver and will probably cost about \$20 to \$80, depending on the performance of the hardware (better cards cost more). Start off your experimentation by teaming up with a nearby ham radio operator and setting each device in the ad-hoc mode and on a common channel. Channels 1 through 6 fall inside the Part 97 frequency allocation. However, channel 1 has output that falls within the AO-40 channel assignment, and channel 6 is commonly used by part 15 devices as the default channel. Using channels 2 through 5 limits the interference you may cause to other operators or have caused to you. Do your initial testing in the same room together. Then as you increase

distances going toward your separate station locations, you can coordinate using a suitable local FM simplex frequency. Frequently hams will use 146.52 MHz or 446.00 MHz, the National FM Simplex Calling Frequencies for the 2-m and 70-cm bands, respectively, for voice coordination. More recently, HSMM radio operators have tended to use 1.2 GHz FM transceivers and handheld transceivers. The 1.2 GHz amateur band more closely mimics the propagation characteristics of the 2.4 GHz amateur band. The rule of thumb being, if you can not hear the other station on the 1.2 GHz FM radio, you probably will not be able to link up the HSMM radios.

HSMM Repeaters

What hams would call a repeater, and in the wired LAN world, computer buffs would call a hub, the WiFi industry refers to as a radio access point, or simply AP. This is a device that allows several Amateur Radio stations to share the radio network and all the devices and circuits connected to it.

An 802.11b AP will sell for about \$80 and an 802.11g AP for about \$100. The AP acts as a central collection point for digital radio traffic, and can be connected to a single computer or to another radio or wired network. Remember to select an AP with performance similar to the performance of the other 802.11 hardware you're using.

The AP identifies itself to its users by means of a station ID or *SSID*. Each AP is provided with an SSID, which is the station identification it constantly broadcasts. For ham purposes, the SSID can be set to your call sign, thus providing automatic, and constant station identification. To use an AP in a radio network the wireless computer users have to exit ad-hoc mode and enter what is called the infrastructure mode, in their operating software.

Infrastructure mode requires that you specify the radio network your computer station is intended to connect to, so set your computer station to recognize the SSID you assigned to the AP (yours or another ham's AP) to which you wish to connect.

Point-To-Point Links: The AP can also be used as one end of a radio point-to-point network. If you wanted to extend a radio network connection from one location to another, for example in order to remotely operate an HF station, you could use an AP at the network end and use it to communicate to a computer at the remote station location.

An AP allows for more network fea-

tures and improved information security than provided by ad-hoc mode. Most APs provide DHCP service, which is another way of saying they will automatically assign an Internet (IP) address to the wireless computers connected to the radio network. In addition, they can provide MAC address filtering which allows only known users to access the network.

Mobile Operating

When hams use the term mobile HSMM station what they are normally talking about is a wireless computer set-up in their vehicle to operate in a stationary portable fashion. Nobody is suggesting that you try to drive a vehicle and look at a computer screen at the same time. That could be very dangerous, and is illegal in some states. So unless you have somebody else to drive the vehicle keep your eyes on the road and not on the computer screen. Additionally, 802.11 was not designed for mobile use and is intolerant of the Doppler shift and signal fades associated with mobile operations.

- What sort of equipment is needed to operate an HSMM mobile station? Some type of portable computer, such as a laptop. Some hams use a PDA, notebook, or other small computing device. The operating system can be Microsoft Windows, Linux, or Mac OS, although Microsoft XP offers some new and innovative WLAN functionality. Some type of radio software hams would call an automatic monitor, and computer buffs would call a sniffer utility. The most common type being used by hams is Marius Milner's Network Stumbler for Windows, or "NetStumbler." All operating systems have monitoring programs available. Linux has Kismet; MAC OS has MacStumbler. Marius Milner has a version for the pocket PC called "MiniStumbler."

- A RIC (Radio Interface Card or PCMCIA WiFi computer adapter card with external antenna port) supported by the monitoring utility you are using. The most widely supported RIC is the Orinoco line. The Orinoco line is inexpensive and fairly sensitive.

- An external antenna attached to your RIC. This is often a magnetically mounted omnidirectional vertical antenna on the vehicle roof, but a small directional antenna pointed out a window or mounted on a small tripod are also frequently used. Be aware of the length and type of cable used to connect the antenna. The small diameter flexible coax often used can exhibit 6 dB of loss per 10 feet! If the antenna needs to be mounted more than 5 feet from the receiver, use LMR 400 or bet-

ter coax so as to minimize line losses. A pigtail or short strain relief cable will be needed to connect from the RIC antenna port to the N-series, RP/TNC or other type connector on the external antenna.

- A GPS receiver that provides NMEA 183 formatted data and computer interface cable will allow the monitoring utility to record where HSMM stations are located on a map just as in APRS. GPS capability is optional, but just as with APRS, it makes the monitored information much more useful since the station's location is provided.

While operating your HSMM mobile station, if you monitor an unlicensed Part 15 station (non-ham), some types of WiFi equipment will automatically associate or link to such stations, if they are not encrypted, and many are not (i.e., WEP is not enabled). Although Part 15 stations share the 2.4 GHz band on a non-interfering basis with hams, they are operating in another service. In another part of this section we will provide various steps you can take to prevent Part 15 stations from automatically linking with HSMM stations. So in like manner, except in the case of a communications emergency, we recommend that you do not use a Part 15 station's Internet connection for any ham purpose.

Area Surveys

Both licensed amateurs and unlicensed (Part 15) stations share the 2.4 GHz band. To be a good neighbor, find out what others are doing in your area before designing your community HSMM radio network. This is easy to do using IEEE 802.11 modulation. Unless it has been disabled, an active repeater (AP) is constantly sending out an identification beacon known as the SSID. In HSMM practice this is simply the ham station call sign (and perhaps the local radio club name) entered into the software configuration supplied with the CD that comes with the repeater. So every HSMM repeater is also a continuous beacon.

A local area survey using appropriate monitoring software, for example free NetStumbler software downloaded and running on your PC (www.netstumbler.com/index.php) is recommended prior to starting up any HSMM operations. Slew your station's directional antenna through 360°, or drive your HSMM mobile station (as described earlier) around your local area.

This HSMM area survey will identify and automatically log most other 802.11 station activity in your area.

There are many different ways to avoid interference with other users of the band when planning your HSMM operating. For example, moving your operating frequency 2-3 channels away from the other stations is often sufficient. Why several channels and not just one? Because the channels as named (1 through 11) are only 5 MHz wide each. The 802.11 carrier is 22 MHz wide, so a single 802.11 carrier occupies multiple numeric channels. Because of this, there is considerable overlap of occupied spectrum if you move only by a single 5 MHz channel. Why this situation exists is because the channel spacing was determined and allocated before the 802.11 standard was promulgated. Since other devices like video transponders, cordless phones, baby monitors, etc. also coexist in the band; it was not necessary or reasonable to change the channel allocations to support the unique behavior of 802.11. So, while there are 11 numeric channels in the Part 15 band, there are only three: 1, 6, and 11 that can support a non overlapped 802.11 carrier. Commercial users often recommend moving 5 channels away from the nearest AP to completely avoid interference. There are six channels within the amateur 2.4 GHz band, but there are problems for hams with two of them. Channel 1 centered on 2412 MHz overlaps into OSCAR satellite downlink frequencies. Channel 6 centered on 2437 MHz is by far the most common out-of-the-box default channel for the majority of WLAN equipment sold in the US, so that often is not the best choice. Subsequently, most HSMM radio groups end up using either channel 3 or channel 4, depending on their local situation. Again, an area survey is recommended before putting anything on the air.

Because of the wide sidebands generated by these inexpensive broad banded 802.11 devices, even moving 2 or 3 channels away from such activity may not be enough to totally avoid interference, especially if you are running what in HSMM is considered high power (typically 1800 mW RF output—more on that subject later). You may have to take other steps. For example, you may use a different polarization with your antenna system. Many HSMM stations use horizontal polarization because much of the non-ham 802.11 activity in their area is primarily vertically polarized.

Special Antenna Systems

There are a number of factors that determine the best antenna design for a specific HSMM radio application.

Most commonly, HSMM stations use horizontal instead of vertical polarization. Furthermore, most HSMM stations use highly directional antennas, instead of omnidirectional antennas. Directional antennas provide significantly more gain and thus better signal-to-noise ratios, which in the case of 802.11 modulation, means higher rate data throughput. Higher data throughput, in turn, translates into more multimedia radio capability.

Highly directional antennas also have many other advantages. Such antennas can allow two hams to "shoot over" or "shoot around" or even "shoot between" other wireless stations on the band. However, the nature of 802.11 modulation coupled with the various configurations of many COTS devices allows hams to economically experiment with many other fascinating antenna designs. Such unique antenna system designs can be used to simply help avoid interference, or to extend the range of HSMM links, or both.

Some APs and some RICs have space diversity capability built-into their design. However, it is not always operated in the same fashion, so check the literature or the Web site of your particular devices to be certain how the dual antenna ports are used. For example, many APs come equipped with two rubber ducky antennas and two antenna ports. One antenna port may be the primary and the other port the secondary input to the transceiver. Which signal input is used may depend on which antenna is providing the best S/N ratio at that specific instant. Experimentation using two outside high-gain antennas spaced 10 or more wavelengths apart (that is only about one meter on the 2.4 GHz band) may be very worthwhile in improving data throughput on long links. Such extended radio paths tend to experience more multi-path signal distortion. This multi-path effect is caused by multiple signal reflections off various objects in the path of the linking signal. The use of space diversity techniques may help reduce this effect and thus improve the data rate throughput on the link. Again, the higher the data rates the more multimedia radio techniques that can be used on that network.

Circular polarization can be considered as linear polarization with the angle of polarization rotating at the same frequency as the transmitted signal. The phase reversal in the electric field when the wave is reflected by a conductive surface causes the rotation sense to reverse. This is an improvement over linear polarization because, for example, right-hand circular polar-

ization (RHCP) changes to left-hand circular polarization (LHCP) on the first reflection, which is usually the strongest reflection. An RHCP antenna at the receiver will then reject the strongest multi-path component with the reversed sense causing the unwanted multi-path component to be down around 20 dB. With linear polarization, although the electric field rotates 180° when the wave is reflected by a conductive surface, the resulting polarization is the same as the incident wave. This does nothing to help reject multi-path distortion at the receiver.

Circular polarization may be created by using helical antennas, patch feed-points on dish antennas, or other means and warrants further study by radio amateurs. Remember this is high-speed digital radio. To avoid symbol errors, circularly polarized antennas should be used at both ends of the link. Also, be certain that the antennas are of the same handedness, for example right hand circular polarization (RHCP). The ability of circular polarization to enhance propagation of long-path HSMM radio signals should not be overlooked.

A combination or hybrid antenna design combining both circularly polarized antennas and space diversity could yield some extraordinary signal propagation results. For example, it has been suggested that perhaps using RHCP for one antenna and LHCP for the other antenna, especially using spacing greater than 10 wavelengths, in such a system could provide a nearly "bullet-proof" design. Only actual field testing of such designs under different terrain features would reveal such potential.

High Power Operation

Hams often ask why operate 802.11 modes under licensed Part 97 regulations when we may also operate such modes under unlicensed Part 15 regulations, and without the content restrictions imposed on the Amateur Radio service? A major advantage of operating under Amateur Radio regulations is the feasibility of legally operating with more RF power output and larger, high-gain directive antennas. These added capabilities enable hams to increase the range of their operations. The enhanced signal-to-noise ratio provided by running high power would also allow better data packet throughput. This enhanced throughput, in turn, enables more multimedia experimentation and communication capability over such increased distances.

Increasing the effective radiated power (ERP) of an HSMM radio link

also provides for more robust signal margins and consequently a more reliable link. These are important considerations in providing effective emergency communications services and accomplishing other important public service objectives in a band increasingly occupied by unlicensed stations and other noise sources.

It should be noted that the existing FCC Amateur Radio regulations covering *spread spectrum* (SS) at the time this is being written were implemented prior to 802.11 being available. The provision in the existing regulations calling for automatic power control (APC) for RF power outputs in excess of 1 W is not considered technologically feasible in the case of 802.11 modulation for various reasons. As a result the FCC has communicated to the ARRL that the APC provision of the existing SS regulations are therefore not applicable to 802.11 emissions under Part 97.

Using higher than normal output power in HSMM radio, in the shared 2.4 GHz band, is also something that should be done with considerable care, and only after careful analysis of link path conditions and the existing 802.11 activity in your area. Using the minimum power necessary for the communications has always been a good operating practice for hams as well as a regulatory requirement.

There are also other excellent and far less expensive alternatives to running higher power when using 802.11 modes. For examples, amateurs are also allowed to use higher gain directional antennas. Such antennas increase both the transmit and the receive effectiveness of the transceiver. Also, by placing equipment as close to the station antenna as possible, a common amateur OSCAR satellite and VHF/UHF DXing technique, the feed line loss is significantly reduced. This makes the HSMM station transceiver more sensitive to received signals, while also getting more of its "barefoot" transmitter power to the antenna. Only after an HSMM radio link analysis (see the link calculations portion of www.arrl.org/hmmm/ or go to logidac.com/gfk/80211link/pathAnalysis.html) clearly indicates that additional RF output power is required to achieve the desired path distance, should more power output be considered.

At that point in the situation analysis, if higher power is required, what is needed is called a bi-directional amplifier (BDA). This is a super fast switching pre-amplifier / amplifier combination that is usually mounted at the end of the antenna pigtail near

the top of the tower or mast. As mentioned before, this is a two-way system, and the link will communicate only as far as the weakest link direction. A BDA needs to be used on both ends of the link in order to achieve greater communication distances. A system with a BDA on only one end may be heard by the far end station, but the BDA equipped station will probably not hear the weaker signal of the "barefoot" far end station. A reasonably priced 2.4 GHz 1800 mW output BDA is available from the FAB Corporation (www.fab-corp.com). It is specifically designed for amateur HSMM radio experimenters. Be certain to specify "HSMM" when placing your order. Also, to help prevent unauthorized use by unlicensed Part 15 stations, the FAB Corp may request a copy of your amateur license to accompany the order, and they will only ship the BDA to your licensee address as recorded in the FCC database.

This additional power output of 1800 mW should be sufficient for nearly all amateur operations. Even those supporting EmComm, which may require more robust signal margins than normally needed by amateurs, seldom will require more power output than this level. If still greater range is needed, there are other less expensive ways to achieve such ranges (see the section HSMM Radio Relays).

When using a BDA and operating at higher than normal power levels on the channels 2 through 5 recommended for Amateur Radio use (these channels are arbitrary channels intended for Part 15 operation and are not required for Amateur Radio use, but they are hard-wired into the gear so we are stuck with them). You should also be aware of the sidebands produced by 802.11 modulation. These sidebands are in addition to the normal 22 MHz wide spread spectrum signal. Accordingly, if your HSMM radio station is next door to an OSCAR ground station or other licensed user of the band, you may need to take extra steps in order to avoid interfering with them. The use of a tuned output filter may be appropriate in order to avoid causing QRM. Even when operating on the recommended channels in the 2-5 range, whenever you use higher than normal power, some of your now amplified sidebands may go outside the amateur band, which stops at 2450 MHz. So from a practical point of view, whenever the use of a BDA is required to achieve a specific link objective, it is a good operating practice to install a tuned filter on the BDA output. Such filters are not expensive and they are readily available from several commer-

cial sources. It should also be noted that most BDAs currently being marketed, while suitable for 802.11b modulation, are often not suitable for the newer, higher speed 802.11g modulation.

There is one further point to consider. Depending on what other 802.11 operating may be taking place in your area, it may be a good practice to only run higher power when using directional or sectional antennas. Such antennas allow hams to operate "over and around" other licensed amateur stations and unlicensed Part 15 activity in your area which you may not wish to disrupt (a local school WLAN, WISP, etc). Again, before running high power, it is recommended that an area survey be conducted using a mobile HSMM rig as described earlier to determine what other 802.11 activity is in your area and what channels are in use.

Information Security

An HSMM radio station could be considered a form of software defined radio. Your computer running the appropriate software combined with the RIC makes a single unit which is now your station HSMM transceiver. However, unlike other radios, your HSMM radio is now a networked radio device. It could be connected directly to other computers and to other radio networks, and even to the Internet. So each HSMM radio (PC + RIC + software) needs to be protected. There are at least two basic steps that should be taken for secure use of all HSMM radios:

The PC should be provided with an anti-virus program. This anti-virus must be regularly updated to remain effective. Such programs may have come with the PC when it was purchased. If that is not the case, reasonably priced anti-virus programs are readily available from a number of sources.

Secondly, it is important to use a firewall software program on your HSMM radio. It is recommended that the firewall be configured to allow no outgoing traffic unless it is coming from a known program, and to restrict all incoming traffic without specific authorization. Commercial personal computer firewall products are available from Symantec, Zone Labs and MCA Network Associates. Check this URL for a list of freeware firewalls for your personal computer: www.webattack.com/freeware/security/fwfirewall.shtml and this one for a list of shareware firewalls for your personal computer: www.webattack.com/Shareware/security/swfirewall.shtml.

Once a group of HSMM stations has

set up and configured a repeater (AP) into a radio local area network (RLAN) then addition steps may need to be taken to restrict access to the repeater. Only Part 97 stations should be allowed to associate with the HSMM repeater. Remember, in the case of 802.11 modulation, the 2.4 GHz band is shared with Part 15 unlicensed 802.11 stations. How do you keep these unlicensed stations from automatically associating (auto-associate) with your licensed ham radio HSMM network?

Many times the steps taken to avoid interference with other stations also limit those other stations' capability to auto-associate with the HSMM repeater, and improve the security of the HSMM station. For example, operating with a directional antenna oriented toward the desired coverage area rather than using an omnidirectional antenna, etc.

The most effective method to keep unlicensed Part 15 stations off the HSMM repeater is to simply enable the Wired Equivalent Protection (WEP) already built into the 802.11 equipment. The WEP encrypts or scrambles the digital code on the HSMM repeater based on the instruction or "key" given to the software. Such encryption makes it impossible for unlicensed stations not using the specified code to accidentally auto-associate with the HSMM repeater.

The primary purpose of this WEP implementation in the specific case of HSMM operating is to restrict access to the ham network by requiring all stations to authenticate themselves. Ham stations do this by using the WEP implementation with the appropriate ham key. Hams are permitted by FCC regulations to encrypt their transmission in specific instances; however, ironically at the time of this writing, this is not one of them. Accordingly, for hams to use WEP for authentication and not for encryption, the key used to implement the WEP must be published. The key must be published in a manner accessible by most of the Amateur Radio community. This fulfills the traditional ham radio role as a self-policing service. The current published ham radio WEP key is available at the home page of the ARRL Technology Task Force High Speed Multimedia Working Group: www.arrl.org/hsmm/.

Before implementing WEP on your HSMM repeater be certain that you have checked the Web site (www.arrl.org/hsmm/) to ensure that you are using the current published WEP key. The key may need to be changed occasionally.

The HSMM Working Group is cur-

rently investigating the feasibility of obtaining a waiver or station temporary authorization (STA) for selected Amateur Radio HSMM experimental stations. The purpose of the waiver would be to allow us to experiment with various wireless content security measures such as *virtual private networking* (VPN). Our research would be restricted to frequencies above 50 MHz and apply only to domestic amateur digital computer-to-computer networking experiments.

Commercial Part 15 Equipment

The IEEE standards for WLAN equipment have evolved from low speeds to high speeds, increasing the spectrum efficiency with each new version. IEEE 802.11 standardized *frequency-hopping spread spectrum* (FHSS) and *direct-sequence spread spectrum* (DSSS) for the 2.4 GHz ISM band to operate at data rates of 1 and 2 Mbps. Next came the release of 802.11b which provided the additional data rates of 5.5 and 11 Mbps but only for DSSS. The purpose of using FHSS and DSSS modulation techniques is to avoid inter-symbol interference (ISI) due to multipath propagation. In FHSS the receiver is on the next frequency when the delayed version of the last symbol arrives on the previous frequency. In DSSS the delayed version no longer matches the spreading code.

This was followed by 802.11g which provided standardization using *Orthogonal Frequency Division Multiplexing* (OFDM) for data rates of 6, 9, 12, 18, 24, 36, 48 and 54 Mbps as well as backward compatibility with 802.11b. As of this writing the most recent release of the standard is 802.11a. This release addresses the use of OFDM in the 5 GHz ISM and UNII bands. It provides the same data rates as 802.11g. The currently unreleased 802.11n standard promises data rates in excess of 108 Mbps.

Of course, none of these increases in capacity come for free. With each increase in capacity comes the need for more complex modulation to support it. As Claude Shannon theorized in 1948, increasing the bandwidth of a fixed size channel leads to the need for more power in order to discern the intelligence from the channel noise. In other words, increasing modulation complexity reduces receiver sensitivity. For example, an 802.11b link operating at 1 MBPS uses BPSK and has a receive sensitivity of around -94 dBm. For an 802.11g link operating at 54 Mbps the modulation is 64QAM, and the receive sensitivity drops to -68 dBm because of the addi-

tional signal to noise ratio required to retrieve the information from 64 possible modulation points rather than the 2 points associated with BPSK.

Note that the power increase is non-linear as doubling the number of states per transmitted symbol increases the number of bits transmitted by an ever-decreasing amount.

Frequency Hopping Spread Spectrum

FHSS radios, as specified in 802.11, hop among 75 of 79 possible non-overlapping frequencies in the 2.4 GHz band. A complete hop sequence occurs approximately every 400 ms with a hop time of 224 μ s. Since these are Part 15 devices the radios are limited to a maximum peak output power of 1 W and a maximum bandwidth of 1 MHz (at -20 dB) at any given hop frequency. The rules allow using a smaller number of hop frequencies at wider bandwidths (and lower power: 125 mW) but most manufacturers have opted not to develop equipment using these options. Consequently, off-the-shelf equipment with this wider bandwidth capability is not readily available to the amateur.

The hopping sequences are well defined by 802.11. There are three sets of 26 such sequences (known as channels) consisting of 75 frequencies each. The ordering of the frequencies is designed as a pseudo-random sequence hopping at least 6 MHz higher or lower than the current carrier frequency such that no two channels are on the same frequency at the same time. Channel assignment can be coordinated among multiple collocated networks so that there is minimal interference among radios operating in the same band.

The FHSS radio can operate at data rates of 1 and 2 Mbps. The binary data stream modulates the carrier frequency using frequency shift keying. At 1 Mbps the carrier frequency is modulated using 2-Level Gaussian Frequency Shift Keying (2GFSK) with a shift of +/-100 kHz. The data rate can be doubled to 2 Mbps by using 4GFSK modulation with shifts of +/-75 kHz and +/-225 kHz.

Direct Sequence Spread Spectrum

DSSS uses digital modulation to accomplish signal spreading. That is, a well-known pseudo-random digital pattern of ones and zeros is used to modulate the data at a very high rate. In the simplest case of DSSS, defined in 802.11, an 11-bit pattern known as a Barker sequence (or Barker code) is used to modulate every bit in the input data stream. The Barker sequence is 10110111000. Specifically, a "zero" data bit is modulated with the Barker sequence resulting in an output sequence of 10110111000. Likewise, a "one" data bit becomes 01001000111 after modulation (the inverted Barker code). These output patterns are known as "chipping" streams; each bit of the stream is known as a "chip". It can be seen that a 1 Mbps input data stream becomes an 11 Mbps output data stream.

The DSSS radio, like the FHSS radio, can operate at data rates of 1 and 2 Mbps. The chipping stream is used to phase modulate the carrier via phase shift keying. Differential Binary Phase Shift Keying (DBPSK) is used to achieve 1 Mbps and Differential Quadrature Phase Shift Keying (DQPSK) is used to achieve 2 Mbps.

Table 1
Bit encoding as a function of data rate

Data Rate, Mbps	CCK encoded bits	DQPSK encoded bits
5.5	2	2
11	6	2

Table 2
Modulation methods and coding rates

Data Rate, Mbps	Modulation	Coding Rate, (R)
6	BPSK	1/2
9	BPSK	3/4
12	QPSK	1/2
18	QPSK	3/4
16	QAM	1/2
36	16QAM	3/4
48	64QAM	2/3
54	64QAM	3/4

The higher data rates specified in 802.11b are achieved by using a different pseudo-random code known as a Complimentary Sequence. Recall the 11 bit Barker code can encode one data bit. The 8 bit Complimentary Sequence can encode 2 bits of data for the 5.5 Mbps data rate or 6 bits of data for the 11 Mbps data rate. This is known as Complimentary Code Keying (CCK). Both of these higher data rates use DQPSK for carrier modulation. DQPSK can encode 2 data bits per transition. Table 1 shows how 4 bits of the data stream are encoded to produce a 5.5 Mbps data rate and 8 bits are encoded to produce an 11 Mbps data rate. There are 64 different combinations of the 8 bit Complimentary Sequence that have the mathematical properties that allow easy demodulation and interference rejection. At 5.5 Mbps only four of the combinations are used. At 11 Mbps all 64 combinations are used. See Fig 2.

As an example, for an input data rate of 5.5 Mbps, four bits of data are sampled at the rate of 1.375 million samples per second. Two input bits are used to select 1 of 4 eight-bit CCK sequences. These 8 bits are clocked out at a rate of 11 Mbps. The two remaining input bits are used to select the phase at which the 8 bits are transmitted.

Orthogonal Frequency Division Modulation

OFDM transmits data simultaneously on multiple carriers. 802.11g and 802.11a specify 20 MHz wide channels with 52 carriers spaced every 312.5 kHz. Of the 52 carriers, four are non-data pilot carriers that carry a known bit pattern to synchronize demodulation. The remaining 48 carriers are modulated at 250 kbaud. The state of all 48 data carriers is known as a symbol. Thus, at any given instant in time 48 bits, or more, of data are being transmitted.

The term "orthogonal" is derived from the fact that these carriers are positioned such that they do not interfere with one another. The center frequency of one carrier's signal falls within the nulls of the signals on either side of it. Figure 1 illustrates how the carriers are interleaved to prevent intercarrier interference. OFDM avoids ISI by making the symbol period much longer than the multi-path delay. A gap is then placed between each symbol to occupy the time consumed by multi-path reflections. The gap is 0.8 microseconds in 802.11a & g.

OFDM radios can be used to transmit data rates of 6, 9, 12, 18, 24, 36, 48 and 54 Mbps as specified by both

802.11a and 802.11g. In order to transmit at faster and faster data rates in the same 20 MHz channel different modulation techniques are employed: BPSK, QPSK, 16QAM and 64QAM. In addition, some of the bits transmitted are used for error correction so the raw data rates could be reduced by up to half of what they would be without error correction. For instance, assuming BPSK (1 bit per carrier) and assuming $\frac{1}{2}$ the bits are used for error correction (known as the coding rate, R); the resulting data rate would be 6 Mbps.

$48 \text{ carriers} \times 1 \text{ bit per carrier} \times \frac{1}{2} R = 24 \text{ bits (effective)}$

$24 \text{ bits} \times 250 \text{ kilo transitions per second} = 6 \text{ Mbps}$

Table 2 shows a complete list of the modulation methods and coding rates employed by 802.11 OFDM. The higher data rates will require better signal strength to maintain error free reception due to using few error correction bits and more complex modulation methods.

Frequencies for HSMM

Up to this point all the discussion has been regarding HSMM radio operations on the 2.4 GHz amateur band. However, 802.11 modulation can be used on any amateur band above 902 MHz, so we can research each of these options.

AM ATV on the 902-928 and 1240-1300 MHz bands is very susceptible to interference (-50 dBc can be seen) so it is would probably be difficult to find a good spot for 802.11 operation in major cities on either of these bands. The 902 MHz band is just 26 MHz wide so 802.11 modulation would occupy almost the entire band. The 1240 MHz band has ATV channels every 12 MHz so it is impossible to avoid interference. Luckily, ATV at 2400 MHz and above is 16 MHz wide FM and is much more immune to interference.

The 3.3-3.5 GHz band offers some real possibilities for 802.11, or the newer 802.16 standard. Activity is centered in three bands at 3.37-3.39 (FM ATV), 3.4-3.41 GHz (European weak-signal modes and U.S. satellite sub-band), 3.456-3.458 (U.S. weak-signal modes) and 3.47-3.49 GHz (FM ATV). There is lots of unused spectrum and frequency transverters could be used to get to this band from 2.4 GHz. Development in Europe of 802.16 with 108 Mbps data throughput may make 3.5 GHz gear available for amateur experimentation in the U.S. In the U.S. the 802.16 development is above the amateur 3.5 GHz band, while the European frequencies used are within the US amateur band. Hams are investi-

gating the feasibility of using such gear when it becomes available in the US for providing a RMAN or radio metropolitan area networks. The RMAN would be used to link the individual HSMM repeaters (AP) or RLANs together in order to provide countywide or regional HSMM coverage, depending on the ham radio population density.

The 5.65-5.925 GHz band is also being investigated. The COTS 802.11a modulation gear has OFDM channels that operate in this Amateur Radio band. The 802.11a modulation could be used in a ham RLAN operating much as 802.11g is in the 2.4 GHz band. It is also being considered by some HSMM groups as a means of providing RMAN links. This band is also being considered by AMSAT for what is known as a C-N-C transponder. This would be an HSMM transponder onboard a Phase 3 high-altitude OSCAR with uplink and downlink pass-band in the satellite sub-bands at 5.65-5.67 and 5.83-5.85 GHz. Some other form of modulation other than 802.11 would likely have to be used because of timing issues and other factors, but the concept is at least being seriously discussed.

The 10 GHz band could also host HSMM activity via transverters. Activity is currently limited to the 10.22-10.28 (WBFM), 10.368-10.37 (weak-signal) and 10.39-10.41 (FM ATV) GHz segments and 10.45-10.5 GHz is reserved for amateur satellites. The bottom 200 MHz of the band would be ideal for HSMM, perhaps in conjunction with ICOM DSTAR systems.

Other RMAN link alternatives are also being tested by hams. One of these is the use of wired networks for linking and the technique known as virtual private networks (VPN). This is similar to the method currently used to provide worldwide FM voice repeater links via the Internet, except that it would be broadband and multimedia. Mark Williams, AB8LN, of the HSMM Working Group is leading a team to test the use of various VPN technologies for linking HSMM repeaters. Mark recently made a presentation on this research at the 2004 Dayton Hamvention during the Technology Task Force (TTF) Forum. This forum is an annual event conducted by the ARRL TTF Chairman, Howard "Howie" Huntington, K9KM. The forum also involves our brothers in the two other TTF working groups: The Software Defined Radio (SDR) Working Group and the Digital Voice (DV) Working Group.

There are also commercial products being developed such as the ICOM DSTAR system which could readily be integrated into a RMAN infrastruc-

Table 3. OFDM Broadcasting Standards

Standard	Digital Radio Mondiale (DRM)	IBOC AM	Digital Audio Broadcasting (DAB)	IBOC FM
Frequency	150 kHz-30 MHz	0.5-1.7MHz	47-230MHz	88-108MHz
Signaling Rate	37.5 Baud	172.3 Baud	47 - 1492 MHz	47-3000MHz
Carrier Spacing	42/47 Hz	181.7 Hz	1605 Baud	6422 Baud
Inter-Symbol Gap	2.7/5.3 ms	300 μ s	2 kHz	8 kHz
Path Differential	250/500 mi.	28 mi.	123 μ s	31 μ s
FFT Sample Rate	6 kSPS	\approx 24 kSPS	2.05 MSPS	2.05 MSPS
Carriers	113/103	105	768	192
Bandwidth	4.9 kHz	18.9 kHz	1.54 MHz	1.54 MHz
Modulation	DQPSK	64QAM	DQPSK	DQPSK

ture, especially with their ATM approach on 10 GHz.

HF frequencies are not being ignored. Neil Sablatzky, K8IT, is leading a team of ham investigators on the HF bands. Digital voice at 2400 BPS has been used on HF so it is possible that fast data rates will become available to efficiently handle e-mail type traffic on the HF bands while still occupying appropriate bandwidth. This would be helpful in an emergency by providing an e-mail outlet for HSMM RMAN e-mail traffic.

John Stephensen, KD6OZH, is leading the HSMM Working Group RMAN-UHF team. John has been investigating HSMM on the UHF amateur bands. 802.11 provides effective communication over short distances with omnidirectional antennas and can be extended to longer distances with highly directional antennas. However, it does not fit within most of the UHF bands and is not efficient at covering wide areas with omnidirectional antennas and may be limited in its HSMM applications to the 2.4 GHz bands and above.

The 802.11 OFDM standards do suggest a solution. OFDM with a slower symbol rate, narrower bandwidth and larger inter-symbol guard band would allow the use of omnidirectional antennas over long paths. In addition, the reduced path loss at lower frequencies will allow coverage of wide areas.

OFDM in Broadcasting

The latest additions to the 802.11 series standardize RF modems using orthogonal frequency division multiplexing or OFDM. This technology provides a bandwidth-efficient method of transmitting digital signals over long distances. OFDM is not only being applied to wireless computer networking but also to broadcasting on frequencies from 150 kHz to 3 GHz. The basic technology is the same, but certain parameters are modified to fit the characteristics of the radio channel. Table 3 shows several OFDM broadcasting standards.

Digital Radio Mondiale (DRM) is a standard for the long wave, medium wave and short wave broadcasting bands¹. It is designed to tolerate the long multi-path delays caused by ionospheric propagation and therefore uses very low symbol rates. The inter-symbol guard band is 2.7-7.3 ms long and can therefore tolerate multi-path delays due to path length differences of up to 700 miles.

The Digital Audio Broadcasting (DAB) standard is a European stan-

dard for terrestrial broadcasting on VHF and UHF bands². Multi-path delays are 1/10th to 1/100th of those in short wave radio and 4 modes of operation are specified. 1 kHz carrier spacing is used for VHF broadcasting and 2 or 4 kHz spacing is used for broadcasting up to 1500 MHz. 8 kHz spacing may be used up to 3 GHz. This system is designed for bands that have no existing analog broadcast stations.

IBOC (in-band on channel) AM and IBOC FM are systems marketed by Ibiqity that have been accepted by the FCC for use in the U.S. medium wave and VHF broadcast bands. Multi-path tolerance is similar to DAB but the bandwidth is narrower. This system is optimized to fit in bands with existing analog broadcasting.

OFDM in Amateur Radio

In the amateur bands, OFDM is being used in the HF bands for digital voice transmission. A 36-carrier OFDM modem was developed by G4GUO and is being marketed by AOR. It has characteristics similar to DRM but uses less than half the bandwidth. When used with an AMBE vocoder with rate 2/3 convolutional coding it has a throughput of 2400 BPS.

For high-speed data transmission, amateurs have been using IEEE 802.11 compliant products in the 13-cm band.^{3,4} Most activity has been with DSSS equipment at a data rate of 11 MBPS. However OFDM modems are now available which operate in the 13-cm and 9-cm amateur bands with data rates up to 54 MBPS. This series of standards were designed for short-range (a few thousand feet) use and therefore tolerate a multi-path differential of only 400 feet. However, they can and are being used over longer distances by using directional antennas to suppress multi-path propagation. Transverters can be constructed to convert 13 cm 802.11 equipment to the 9, 3 and 1.2-cm bands.

There is a gap between the capabilities of the 802.11 and G4GUO modems that needs to be filled. The VHF and UHF amateur bands are ideal for multi-point local communication, as path losses are low with omnidirectional antennas. An OFDM RF modem with high data rates and longer multi-path delay tolerance would allow operation in urban areas over both line-of-sight (LOS) and non-line-of-sight (NLOS) paths.

In the effort to research various alternatives to linking Amateur Radio 802.11-based repeaters together, the HSMM Working Group has established several Radio Metropolitan Area Network (RMAN) project teams

¹Notes appear on page 17.

Table 4. OFDM Modems for the Amateur Radio Service

Standard	RMAN-UHF Draft Standard							IEEE 802.11
Signaling Rate	50 baud	937.5 baud		7500 baud			250 kbaud	
Carrier Spacing	62.5 Hz	1171.875 Hz		9375 Hz			312.5 kHz	
IS Gap	4 ms	213.3 μ s		26.7 μ s			0.8 μ s	
Multi-path	750 miles	40 miles		5 miles			800 feet	
Frequency (MHz)	1.8-30	219-450 (50-450*)	420-450 (222-450*)	420-450 (222-450*)	902-2400 (222-2400*)	902-2400 (222-2400*)	902-2400 (222-2400*)	2,400-10,500
FFT Sample Rate	4 ksps	150	300	1200	1200	2400	9600	20,000
Pilot Carriers	0	1	1	1	1	1	1	4
Data Carriers	36	64	128	512	64	160	512	48
Chan. Spacing	4	100	200	750	750	2000	6000	25,000
Bandwidth (kHz)	2.3	78	153	603	620	1520	4820	17,000
Low Rate (ksps)	2.4	120	240	960	960	2400	7680	6000
Modulation	DQPSK	D8PSK	D8PSK	D8PSK	D8PSK	D8PSK	D8PSK	BPSK
FEC Rate	2/3	2/3	2/3	2/3	2/3	2/3	2/3	1/2
High Rate (ksps)	-	240	480	1920	1920	4800	15,360	54,000
Modulation	-	64QAM	64QAM	64QAM	64QAM	64QAM	64QAM	64QAM
FEC Code Rate	-	2/3	2/3	2/3	2/3	2/3	2/3	3/4

*Under ARRL proposed regulations based on signal bandwidth.

lead by experts in their respective fields. These teams currently consist of the RMAN-VPN Project lead by Mark Williams, AB8LN; the RMAN-DSTAR and AMSAT C&C Project lead by John Champa, K8OCL; the RMAN-802.16 and Mesh Networking Project lead by Gerry Creager, N5JXS; the RMAN-UHF Project lead by John Stephensen, KD6OZH and the HSMM-HF Project (for e-mail) lead by Neil Sablatzky, K8IT.

John Stephensen, KD6OZH, as RMAN-UHF Project Leader, has been researching various alternatives for digital metropolitan area networks in the UHF amateur bands. The IEEE has developed the 802.16 WMAN standard, but this is for operation above 2 GHz and the bandwidth required is more than can be made available in the UHF amateur bands. Consequently, we need to develop an amateur standard for data transmission in the UHF bands. The HSMM group is tasked with developing links at data rates above 56 kbps and operation at 384 kbps or above is desirable as this supports full-motion compressed video.

OFDM Modem Physical Layer

The UHF amateur bands fall into 2 categories. The FCC limits the bandwidth available for data transmission in the 219-220 MHz and 420-450 MHz bands to 100 kHz, but there is no limit for the bands at 902 MHz and above. There is a practical limit of 6 MHz in the 902-928 MHz, 1240-1300 MHz, 2300-2305 MHz and 2390-2450 MHz bands because they are shared with existing users of analog modes. The goal is to develop a series of modems that operate above 56 KBPS and span the range of bandwidths available within the ARRL band plans. Table 4 shows the characteristics of OFDM modems being used in the amateur bands today

and the proposed standard described in this document. The bandwidths for the modems were chosen to fit off-the-shelf SAW filters used in GSM, CDMA and cable TV equipment.

The modem design was strongly influenced by the DAB standard as it operates in the same frequency range and supports both mobile and fixed users. Radio propagation in an urban area is characterized by strong multi-path propagation. Propagation measurements indicate that multi-path delay ranges from 0.4 to 10 μ s typically and up to 90 μ s worst case for LOS and NLOS paths in an urban environment. The modems defined in the middle seven columns of Table 4 use either 7500-Baud symbol rates with 9.375 kHz carrier spacing or 937.5-baud symbol rates with 1172-Hz carrier spacing. This results in an active symbol time of $T_s = 106.7$ or 853.3μ s with a guard band of $T_g = 26.7$ or 213.3μ s between adjacent symbols. The guard band is filled with a copy of the last $\frac{1}{4}$ of the OFDM symbol as shown in Figure 3.

The lowest speed modem is designed to fit in a 100-kHz channel and uses 64 data carriers plus a pilot carrier as shown in Figure 4. The pilot carrier is transmitted at 3 dB above the level of the data carriers and is placed in the center of the channel. Half of the data carriers are placed on each side of the pilot carrier and enumerated 1 through 64 from the lowest frequency to the highest frequency. The major lobes of the data carriers occupy 78 kHz. Extending beyond that limit on either side are the minor lobes of these carriers. Since the first minor lobe is at -13 dBc and the amplitude decreases at only 6 dBc/octave, additional filtering is required. A FIR filter with flat group delay must be used to attenuate minor lobes to -34 dBc at ± 50 kHz.

Eight-phase differential phase shift keying (8DPSK) is used for the low data rate to allow mobile operation. As the station moves, the absolute phase varies as the strength and delay of multi-path rays vary so a fixed phase reference cannot be used. In-

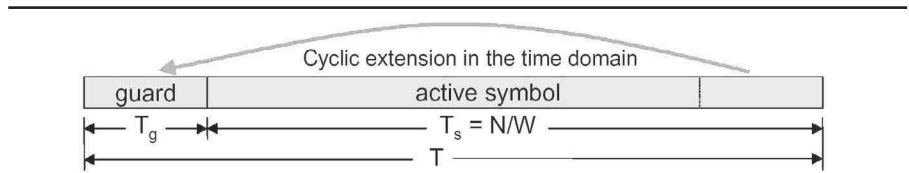

Fig 3—Guard Band

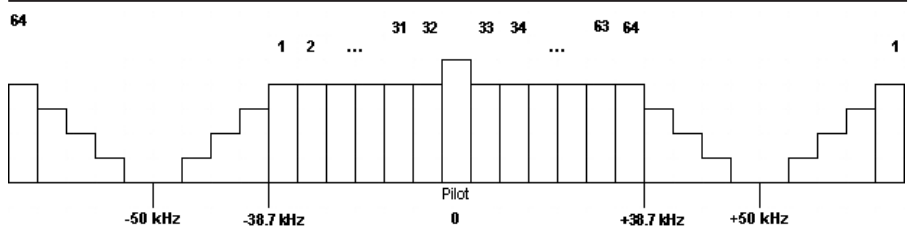

Fig 4—Format for 125 kHz Channel Spacing

stead the difference between the phase of the current symbol and the previous symbol is used to determine the value transmitted. Three coded bits are transmitted per symbol per carrier as shown in Table 5.

Trellis-Coded Modulation

Since the transmission channel will corrupt the transmitted data due to noise and fading, a forward error correcting (FEC) code must be used to provide adequate performance at reasonable signal to noise ratios (SNR). A plain block convolutional code could be used for FEC but it is much more efficient to use an error correcting code that is integrated with the modulation method. This is called trellis-coded modulation or TCM⁵ and we will use a rate 2/3 trellis-code where 2 data bits (x^1 and x^2) are converted into a 3-bit code word (y^0 , y^1 and y^2).

In TCM the signal constellation is partitioned into subsets as shown in Figure 5. Each partitioning increases the distance between constellation points. A convolutional coding of $xn1$, as shown in Figure 6, generates $y0$ and $y1$, which are used to select between the subsets C0, C1, C2, and C3 at the receiver. The data bit $x2 = y2$ then selects the final value.

The coding decreases the error rate because it increases the sequential distance between codes. The coded bits, y_{0-2} , may assume only certain sequences of values that are dependent on the state of the convolutional encoder, S_{0-1} , and the input, x_1 , as shown in Figure 6.

Viterbi Decoding

The receiver can use this information to find the allowed sequence of symbols that is closest in Euclidean distance to the received sequence of symbols and determine the state of the convolutional coder in the transmitter. This is usually done using the Viterbi algorithm⁶ with a soft-decision input.

The input is not a 3-bit vector, but a set of eight probabilities that the transmitted signal matches each of the eight signal constellation points shown in Fig 7. The algorithm associates a distance metric with each possible sequence of received signals and selects the maximum-likelihood path. The selection is made by tracing back the possible signal sequences and detecting segments that are common, as shown in Figure 8 (ML segment).

After determining the transmitter's state, the uncoded bit, x_2/y_2 , is decoded by selecting the closest point in the remaining subset of the signal constellation. This is equivalent to decoding a BPSK data stream so the ultimate error rate for trellis-coded 8PSK is the same as for BPSK data. This results in a considerable coding gain, as the number of data bits actually received is double what BPSK would deliver. Figure 9 shows the gain provided by trellis-coded 8PSK compared to QPSK.

Since the outer Reed-Solomon code works on symbols, the event error rate curve is the one that is relevant.

Higher Data Rate

When the SNR is high, and the transmission path characteristics are stable, transmitting 4-bits per carrier results in a rate twice the basic data rate. This can be done in fixed stations where the phase of the received signal does not change rapidly. 64QAM modulation is used with a rectangular constellation as shown in Figure 10. The in-phase (I) and quadrature (Q) components of the signal are orthogonal and are treated separately in the encoding and decoding process. Two data bits are converted to three coded bits as was done for 8DPSK. One set of bits modulates the I carrier and another modulates the Q carrier as shown in Table 6. The maximum I and Q amplitude is limited to 0.7 so that the vector sum will not exceed 1.0.

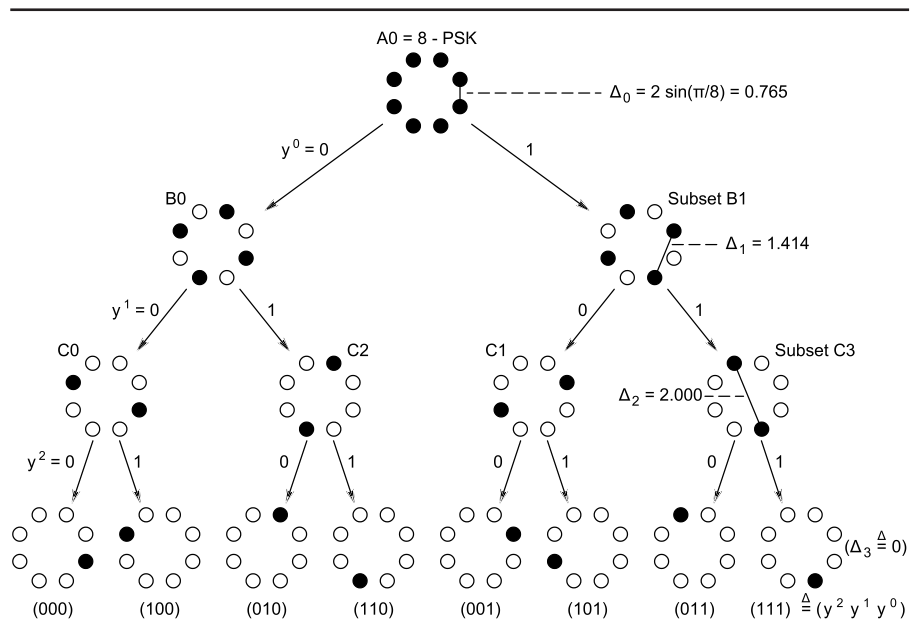

Fig 5—Signal Constellation Partitioning

Table 5
D8PSK Encoding

Tribit $y_2 y_1 y_0$	Carrier Phase Shift
0 0 0	0°
0 0 1	45°
0 1 0	90°
0 1 1	135°
1 0 0	180°
1 0 1	225°
1 1 0	270°
1 1 1	315°

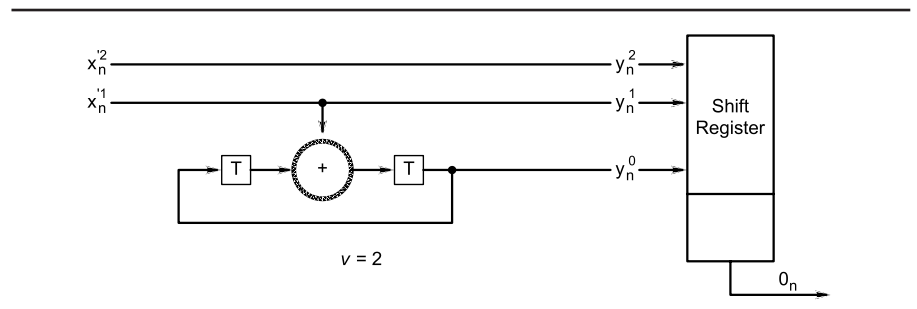

Fig 6—Convolutional Coding

Symbol Synchronization

To properly demodulate the 8DPSK or 64QAM encoded information, the receiver must maintain proper symbol synchronization as shown in Figure 11. This causes the inter-symbol interference (ISI) to be ignored when the fast Fourier transform (FFT) is calculated to demodulate the individual carriers.

Two special symbols are used for synchronization. Since the phase of the incoming carriers is in flux during the first part of the OFDM symbol period, the total amplitude of all carriers is used to delimit the symbol period. A special maximum amplitude symbol, called the reference (REF) symbol is defined, where the absolute phase of each carrier is set according to the formula:

$$q = 3.6315 k^2$$

where k is the carrier index by frequency⁷. This pattern minimizes amplitude distortion due to selective fading. In addition, the crest factor of the REF symbol waveform is less than 5 dB so that the reference symbol can be transmitted at 3 dB above normal power levels to improve amplitude and phase estimation.

The second special symbol is the null (NUL) symbol, which consists of the pilot carrier and no data carriers. The sequence REF-NUL-REF is present at the beginning of each data frame. The receiver normally uses a moving average filter with a time constant of one symbol period to detect end of the NUL symbol, as shown in Figures 12 and 13.

The REF-NUL-REF sequence is inserted into the transmitted data stream every 125 symbols. This reduces the required symbol clock accuracy to ± 100 PPM. The REF symbol after the NUL is then used as an amplitude and phase reference for demodulating the following symbols. The format of a complete physical layer protocol data unit (PHY-PDU) is shown in Figure 14.

Protocol Control Information

The PHY-PDU begins with 8 PIL symbols. The PIL symbol is a full amplitude pilot carrier with no data carriers.

The high amplitude single carrier (PIL symbols) allows the receiver to acquire carrier frequency lock more easily. This is followed by the REF-NUL-REF sequence and a 1 to 125-symbol data block. If more than 125 symbols are to be transmitted, all blocks but the last have 125 data symbols. The PHY-PDU ends with a PIL symbol.

MAC Sublayer Error Correction

The physical layer provides forward error correction to compensate for errors due to Gaussian noise. However, the radio communications channel is also subject to fading and/or impulse noise that may introduce errors in bursts. The error correction provided in the physical layer may be overwhelmed and bytes containing errors may be delivered to the MAC sublayer. Reed-Solomon codes are particularly good at correcting bursts of errors and one is used in the MAC sublayer to alleviate this problem. This type of code operates on symbols m -bits wide, taking a block of k symbols and adding parity bits to form a block of n symbols where $n = 2m - 1$. The encoded block consists of the k original symbols plus $n - k$ parity symbols, as shown

in Figure 15, and is capable of correcting $t = (n - k) / 2$ symbol errors.

The code used is an RS (255,223) code that operates on 8-bit symbols and will correct errors in up to 16 symbols per block with an overhead of 12.6%. When 223 data bytes are available for transmission, an encoded block of 255 bytes is generated. The parity symbols are created by dividing a polynomial represented by the k data symbols by the RS generator polynomial. The symbols in the remainder are the parity symbols. If the end of the PHY-SDU is reached and the number of data bytes to be transmitted is less than 223, a shortened code block is generated.

At the receiver, the process of detecting an error is fairly simple, but correcting errors requires a lot of computation, as shown in Figure 16. As

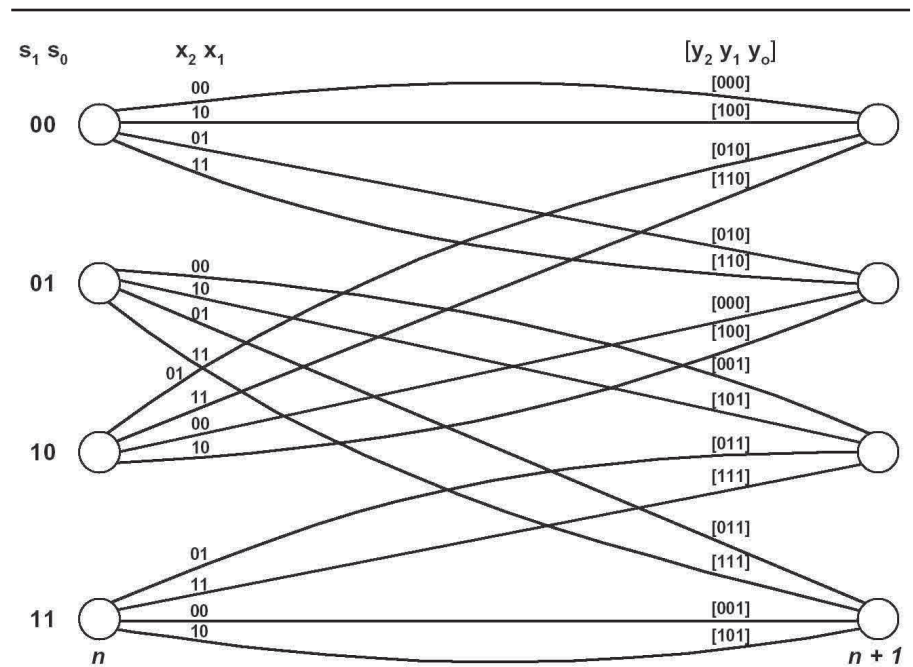

Fig 7—Allowed State Transitions

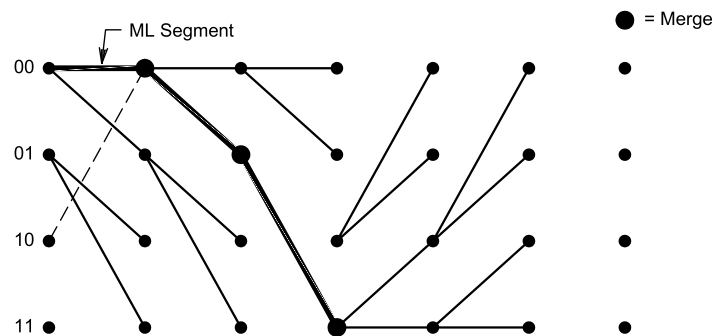

Fig 8—Viterbi Decoding

the data and parity symbols are received, they are divided by the generator polynomial and the remainder, called the syndrome, is zero if there are no errors. If the syndrome is not zero, the syndrome is processed to locate the errors. There are $2t$ simultaneous equations to be solved with the unknowns being the t locations of errors. The solution can be found in two steps. First the equations are solved using an iterative algorithm, such as Euclid's algorithm or the Berlekamp-Massey algorithm. This generates an error polynomial whose roots are the locations of the corrupted symbols. The error polynomial is then evaluated to find its roots using an exhaustive search, such as the Chien search. The error values are then calculated us-

ing the syndromes and the error polynomial roots. This is usually done using the Forney algorithm, which performs a matrix inversion. The error values are then exclusive-ORed with the received data to correct the errors.

MAC Service

This MAC entity is designed to provide a standard IEEE 802.3-style MAC service to the user. The user sends and receives service data units up to 1,536 bytes in length. The sender is identified by the source MAC address and the receiver is identified by the destination MAC address. Addresses are 48 bits in length and may be either individual or group addresses. Individual addresses consist

of a six-character amateur-radio-service call sign plus a one-character extension. Group addresses are arbitrary 7-character strings. Characters are encoded in 6-bit ASCII.

Since the physical layer transmits up to 128 bytes per OFDM symbol, each station will accumulate multiple MAC protocol data units (MPDUs) for transmission in one PHY-SDU whenever possible. Each MPDU consists of MAC protocol control information (MPCI) and, optionally, a MAC service data unit (MSDU). Figure 17 shows an example with five MPDUs with three containing MSDUs. The maximum PHY-SDU length is 5,184 bytes.

MPDU Formats

There are three types of MPDUs defined. A Data MPDU transports a complete MSDU. It consists of 21-bytes of MPCI containing the address and type fields followed by a variable-length user-data field as shown in Figure 18. The MPCI fields are the intermediate address (IA), destination address (DA), source address (SA) and length (L). DA, SA and L are obtained from the MAC service user while IA is generated by the MAC entity. IA is the next destination address while DA is

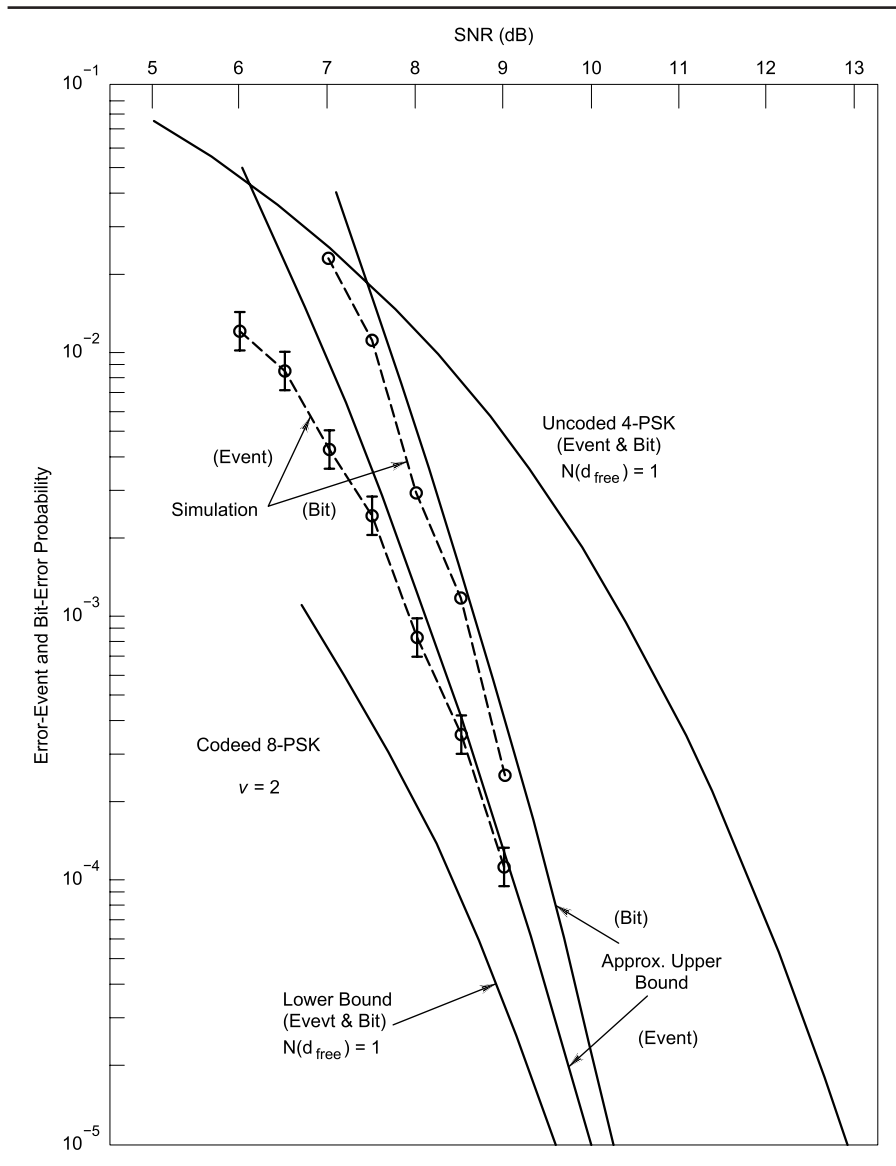

Fig 9—TC8PSK vs. QPSK

0,7	1,7	2,7	3,7	4,7	5,7	6,7	7,7
0,6	1,6	2,6	3,6	4,6	5,6	6,6	7,6
0,5	1,5	2,5	3,5	4,5	5,5	6,5	7,5
0,4	1,4	2,4	3,4	4,4	5,4	6,4	7,4
0,3	1,3	2,3	3,3	4,3	5,3	6,3	7,3
0,2	1,2	2,2	3,2	4,2	5,2	6,2	7,2
0,1	1,1	2,1	3,1	4,1	5,1	6,1	7,1
0,0	1,0	2,0	3,0	4,0	5,0	6,0	7,0

Fig 10—64QAM Signal Constellation with Coded I and Q Tribits shown in Octal

Table 6
64QAM Encoding

Tribit	I & Q Amplitude
$y_2 y_1 y_0$	
0 0 0	-0.7
0 0 1	-0.5
0 1 0	-0.3
0 1 1	-0.1
1 0 0	+0.1
1 0 1	+0.3
1 1 0	+0.5
1 1 1	+0.7

the ultimate destination address. A secondary station may be set IA to the primary station address to cause it to forward data to another secondary station that it cannot reach directly.

Access is controlled by a primary station that polls multiple secondary stations for traffic. It transmits a token that confers the right to transmit to the addressed secondary station. The secondary station then transmits any accumulated traffic and gives the token back to the primary station. The Token MPDU contains the address of the primary station (PA) and the next secondary station (SA) to transmit as shown in Figure 19.

Stations exchange received signal strength indication (RSSI) reports to determine what other stations are reachable in a network. The primary station periodically transmits an RSSI MPDU to each secondary station and the secondary stations respond by broadcasting RSSI MPDUs. Each station builds up a database of neighbor stations with the strength of its signal at each neighbor and the transmission capabilities of each neighbor. This can be used to select the modulation method and number of carriers to use when transmitting to adjacent stations.

The RSSI MPDU reports the received signal strength (SNR) for one or more transmitting stations (TA) at a particular receiving station (RA) as shown in Figure 20. The TA and RSSI fields are repeated N times. The C and M fields indicate the transmitter capabilities at the reporting station. C is the maximum number of data carriers supported divided by 4. M is the maximum number of bits transmitted per data carrier.

OFDM Modem Hardware

The OFDM modem described here is being implemented on the DCP-1 digital signal processing board. The DCP-1 uses an Xilinx Spartan-3 FPGA to implement the physical layer of the modem and an Oki Semiconductor ML67Q5000 MCU to implement the MAC sublayer. The received signal is digitized at the IF frequency by a 14-bit ADC at 19.2 Msps and transmitter I and Q baseband signals are generated by a dual 14-bit DAC at 9.6 Msps. The DCP-1 connects to its host via RS-232 or RS-485 up to 230.4 kbps or via USB at 12 Mbps or 480 Mbps. This hardware will be made available to amateurs by one of the authors, KD6OZH.

To allow the widest possible software compatibility, the modem will emulate an IEEE 802.11 LAN controller. For point-to-point operation, individual

LAN addresses would be Amateur Radio service call signs. The net control stations call sign or an alphanumeric multicast address could be used for multi-point operation. Station identification is automatic, as the transmitting station's call sign is always the source address. Since the DCP-1 has an RS-232 interface, an interface that would emulate either a dial-up modem

or a TNC in KISS mode is also being considered. This may be useful at low data rates for compatibility with older computers or legacy software is also being considered.

Conclusion

We expect to have OFDM modems using 8DPSK modulation operational and being tested in the field this year.

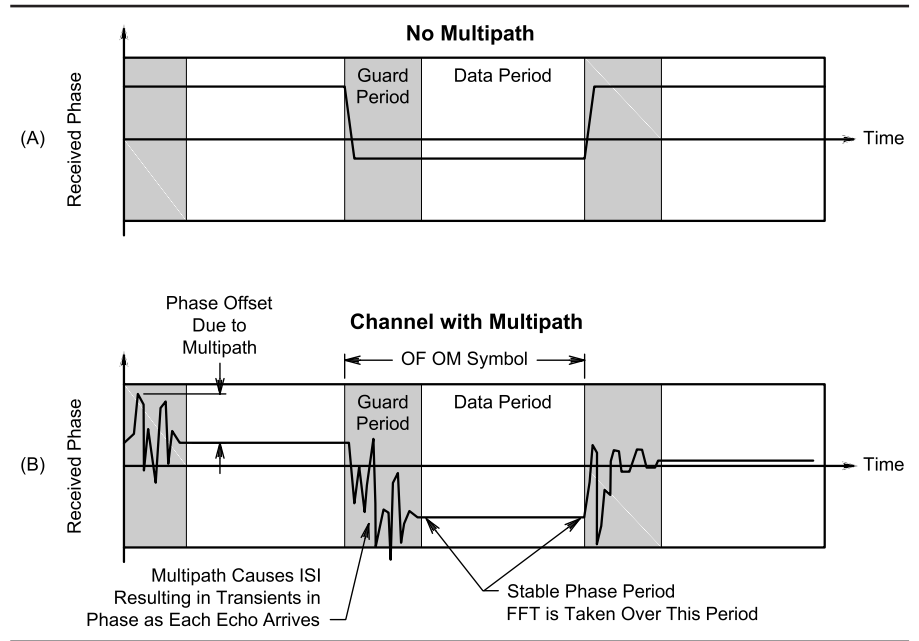

Fig 11—ISI Rejection using Guard Band

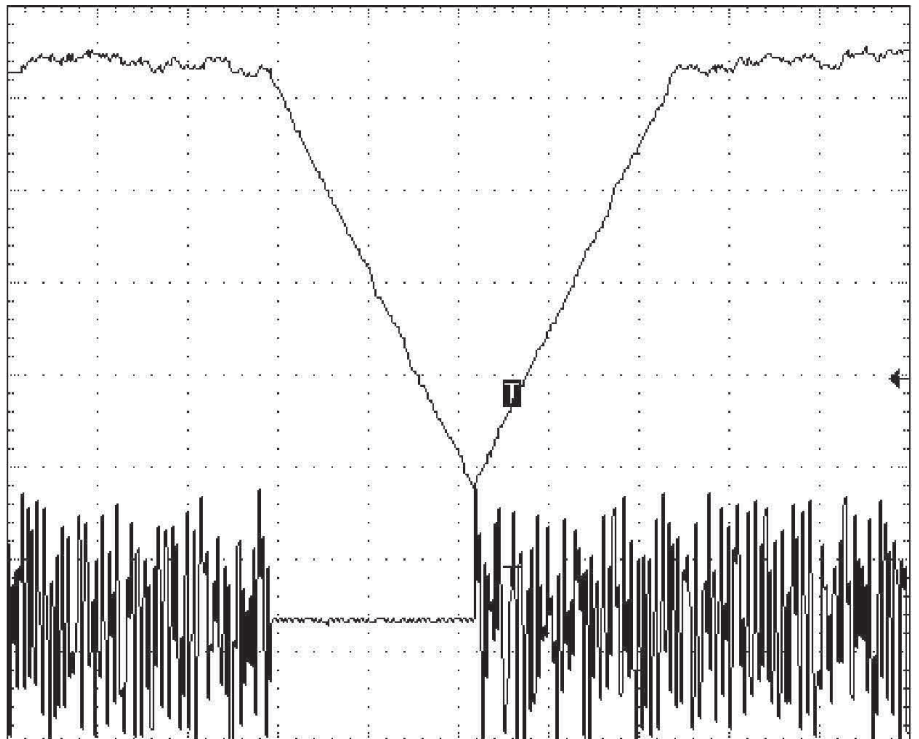

Fig 12—Synchronization with Normal REF Symbol

The source code will be made public and interested amateurs can modify or improve it as desired. The full specification is available from the HSMM working group. OFDM will allow a number of new applications in the UHF amateur bands and should provide much higher reliability than older technologies such as AFSK and FSK without FEC.

A 937.5-Baud OFDM modem can support data rates up to 240 Kbps in the 219-220 MHz band and up to 1.92 Mbps in the 420-450 MHz band. Operation in the 219 and 420 MHz bands is interesting because 100-W and higher-power amplifiers are available and the

path loss is low. This allows the exploitation of paths with high losses. The low baud rate allows a wide (213.3-ms) guard band to suppress ISI for operation over NLOS paths that would be impossible with other types of equipment. The transmission characteristics should be ideal for mobile operation. Pure data transmission would be limited to 240 kbps by the current FCC regulations, but compressed video could be transmitted at the higher data rates as it would be classified as digital ATV. Since the modems will be implemented in software, the occupied bandwidth and data rate can be changed to accommodate FCC regulations and the cur-

rent propagation conditions.

OFDM could enable mobile ATV, which is impossible with analogue techniques. You could turn on a video camera and the operator on the "talk-in" frequency at a hamfest could see where you are and provide better directions. This capability could prove invaluable in emergency situations. At the home station, applications such as NetMeeting could be used to allow radio club meetings to take place over the air. Presentations could be relayed over the video link. This would be very useful for members with physical disabilities. These data rates are also useful for linking clusters of computers where the main source of traffic is email or facsimile or where the Internet connection is a temporary dial-up link. The 120 or 240 kbps data rates should be adequate for forwarding health and welfare traffic at Red Cross shelters. This type of link also provides some level of security, as the general public won't have compatible equipment.

The 7500-baud modems can provide higher data rates and may be used on the 33, 23 and 13-cm bands. They are ideal for 802.11 AP linking as they can accommodate T1 data rates for applications that require database access or video. The ability to operate in the 23-cm band eliminates the interference present on 13-cm and allows longer paths to be accommodated when compared to 802.11 modems. This is ideal for linking 802.11 APs serving clusters of computers at remote sites.

There are probably many other applications that haven't been thought of yet—Amateur Radio operators will always find new uses for state-of-the-art technology.

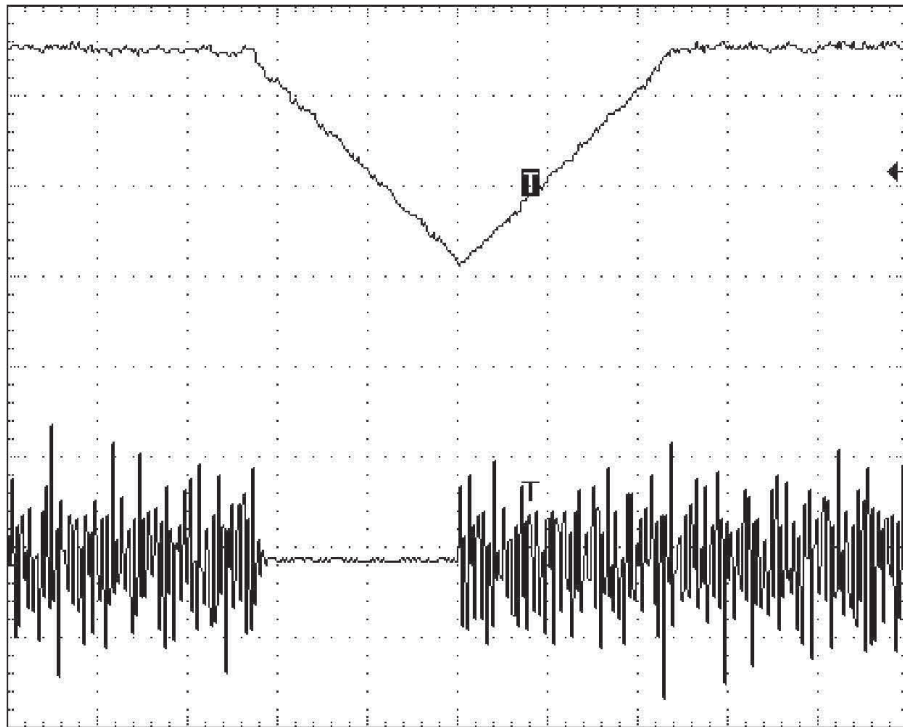

Fig 13—Synchronization with Selective Fading

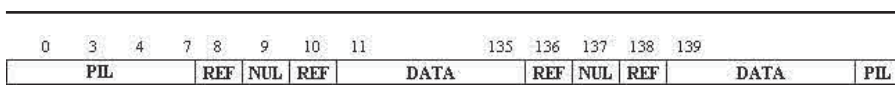

Fig 14—PHY-PDU Format (2 data blocks)

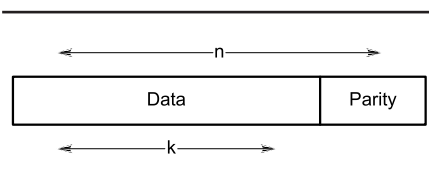

Fig 15—RS(n,k) Encoded Block

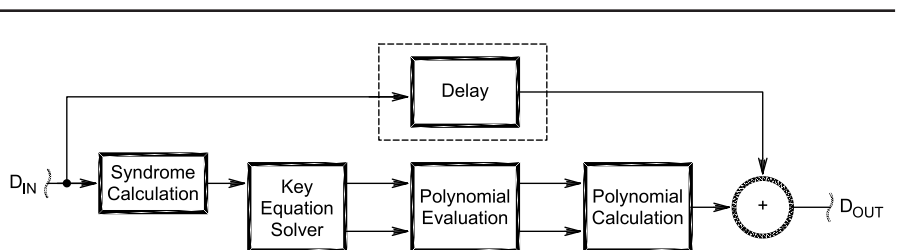

Fig 16—RS Error Correction Process

Notes

- ¹"Digital Radio Mondiale (DRM); System Specification," ETSI TS 101 980 v1.1.1 (2001-09).
- ²"Radio Broadcasting Systems; Digital Audio Broadcasting (DAB) to mobile, portable and fixed receivers," ETS 300 401, second edition, May 1997.
- ³"Supplement to IEEE Standard for informa-

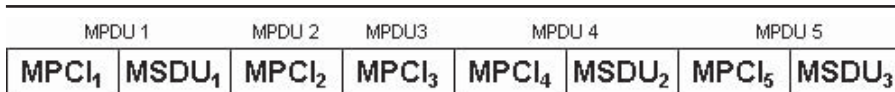

Fig 17—PHY-SDU with Multiple MPDUs

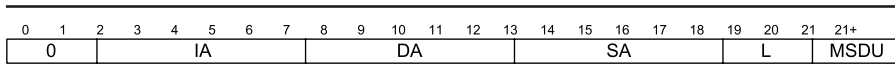

Fig 18—Data MPDU

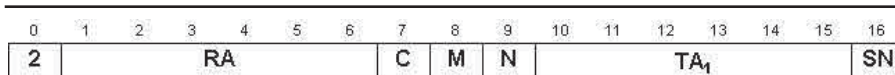

Fig 20—RSSI MPDU with one signal report

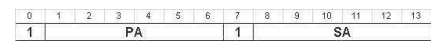

Fig 19—Token MPDU

J. Geier, *Wireless LANs, Implementing High Performance IEEE 802.11 Networks*, Second Edition, SAMS, 2002.

G. Held, *Building a Wireless Office*, Auerbach, 2003.

C. Holmes, *Coherent Spread Spectrum Systems*, New York, NY. Wiley Interscience, 1982

K. Husain, and T. Parker, Ph.D., et al. *Linux Unleashed*, SAMS, 1995.

A. Kesteloot, N4ICK, "Practical Spread Spectrum: An Experimental Transmitted-Reference Data Modem," *QEX*, July 1989, pp. 8-13.

T. McDermott, "Wireless Digital Communications: Design and Theory", *TAPR*, 1996.

K. Mraz, N5KM, "High Speed Multimedia Radio," *QST*, April 2003, pp. 28-34.

R. Olexa, KA3JJI, "Wi-Fi for Hams Part 1: Part 97 or Part 15," *CQ*, June 2003, pp. 32-36.

R. Olexa, KA3JJI, "Wi-Fi for Hams Part 2: Building a Wi-Fi Network," *CQ*, July 2003, pp. 34-38.

R. Olexa, KA3JJI, *Implementing 802.11, 802.16, and 802.20 Wireless Networks Planning, Troubleshooting, and Operations*, Elsevier, 2004

B. Patil, et. al. *IP in Wireless Networks*, Prentice Hall, 2003.

B. Potter, and B. Fleck, *802.11 Security*, O'Reilly, 2003.

H. Price, NK6K, "Spread Spectrum: It's Not Just for Breakfast Any More!" (*Digital Communications*), *QEX*, June 1995, pp. 22-27.

T. Rappaport, N9NB, "Spread Spectrum and Digital Communication Techniques: A Primer," *Ham Radio*, December 1985, pp. 13-16, 19-22, 24-26, 28.

J. Reinhardt, AA6JR, "Digital Hamming: A Need for Standards," *CQ*, January 2003, pp. 50-51.

P. Rinaldo, W4RI, and J. Champa, K8OCL, "On The Amateur Radio Use of IEEE 802.11b Radio Local Area Networks," *CQ VHF*, Spring 2003, pp. 40-42.

D. Rotolo, N2IRZ, "A Cheap and Easy High-Speed Data Connection," *CQ*, February 2003, pp. 61-64.

N. Sablatzky, K8IT, "Is (sic) All Data Acceptable Data," *CQ VHF*, Fall 2003, pp. 48-49.

M. Simon, J. Omura, R. Scholtz, and K. Levitt, *Spread Spectrum Communications Vol I, II, III*, Rockville, MD. Computer Science Press, 1985

D. Torrieri, "Principles of Secure Communication Systems," Boston, Artech House, 1985.

B. Wyatt, K6WRF, "Remote-Control HF Operation over the Internet," *QST*, November 2001, pp. 47-48.

R. Ziemer, and R. Peterson, "Digital Communications and Spread Spectrum Systems," New York, Macmillan, 1985.

John Champa, K8OCL, is Chairman of the ARRL HSMW Working Group. John B. Stephensen, KD6OZH, is the RMAN-UHF Project Leader of the ARRL HSMW Working Group □□

tion technology—Telecommunications and information exchange between systems—Local and metropolitan area networks—Specific requirements—Part 11: Wireless LAN Medium Access Control (MAC) and Physical Layer (PHY) Specifications—High-Speed Physical Layer in the 5 GHz Band," ISO/IEC 8802-11:1999/Amd 1:2000 (E).

⁴⁴IEEE Standard for information technology – Telecommunications and information exchange between systems – Local and metropolitan area networks – Specific requirements—Part 11: Wireless LAN Medium Access Control (MAC) and Physical Layer (PHY) Specifications: Amendment 4 - Further Higher Rate Data Extension in the 2.4 GHz Band," IEEE Std 802.11g-2003.

⁵⁴Trellis Coded Modulation with Redundant Signal Sets," Gottfried Ungerboeck, *IEEE Communications Magazine*, February 1987 – Vol. 25, No. 2.

⁶⁴Self-Correcting Codes Conquer Noise, Part 1: Viterbi CODECS," Syed Sabzad Shah, *EDN*, February 15, 2001.

⁷⁴Adaptive Techniques for Multi-user OFDM," Eric Phillip Lawrey, James Cook University, December 2001.

Bibliography

M. Burger, AH7R, and J. Champa, K8OCL, "HSMW in a Briefcase," *CQ VHF*, Fall 2003, p. 32.

J. Champa, K8OCL, and R. Olexa, KA3JJI, "How To Get Into HSMW," *CQ VHF*, Fall 2003, pp. 30-36.

T. Clark, W3IWI, "C-C RIDER, A New Concept for Amateur Satellites", *Proceedings of the AMSAT-NA 21st Space Symposium*, November 2003, Toronto, Ontario, Canada (this book is available from the ARRL Book Store).

G. Cooper and C. McGillem, *Modern Communications and Spread Spectrum*, New York, McGraw-Hill, 1986.

J. Duntemann, K7JPD, *Jeff Duntemann's Wi-Fi Guide*, Paraglyph Press, 2003.

H. Feinstein, WB3KDU, "Spread Spectrum: Frequency Hopping, Direct Sequence and You," *QST*, June 1986, pp. 42-43.

R. Flickenger, *Building Wireless Community Networks – 2nd Edition*, O'Reilly, 2003. (This book is available from the ARRL Book Store).

R. Flickenger, *Wireless Hacks*, O'Reilly, 2003.

S. Ford, WB8IMY, "VoIP and Amateur Radio," *QST*, February 2003, pp. 44-47.

S. Ford, WB8IMY, *ARRL's HF Digital Handbook*, American Radio Relay League, 2001.

M. Gast, *802.11 Wireless Networks, The Definitive Guide*, O'Reilly, 2002. (This book is available from the ARRL Book Store).

Maximize Microwave Performance

Model 1152
PLL for DEMI Transverters

Model 5112
PLL for DB6NT Transverters

Model M10K
5 to 10GHz Multiplier-LO/Beacon Use

Model SEQ-1
Micro-Controlled Sequencer

Model 10224
PL Dielectric Resonate Oscillator



jwm
ENGINEERING GROUP

949-713-6367 / <http://www.jwmeng.com/qex.html>