

NXDN[®]

NXDN Technical Specifications

Part 2:

Conformance Test

Sub-part E:

Trunking Operation Test (Type-D)

NXDN TS 2-E Version 1.0

November 2012

NXDN Forum

Contents

- 1.Introduction 1
- 2.References 1
- 3.Abbreviations 1
- 4.Outline 2
- 5.Test Procedures..... 3
 - 5.1.SU Testing 4
 - 5.1.1.Link Tests 4
 - 5.1.1.1.Link Accept Test..... 4
 - 5.1.1.2.Link Refuse..... 5
 - 5.1.1.3.Link of Traffic Repeater 6
 - 5.1.2.Group Voice Call Tests 10
 - 5.1.2.1.Conference Group Call Test..... 10
 - 5.1.2.2.Broadcast Group Call Test 12
 - 5.1.3.Individual Voice Call Tests 13
 - 5.1.3.1.Individual Call Test 13
 - 5.1.4.All Call Tests..... 14
 - 5.1.4.1.Testing the Calling SU 14
 - 5.1.4.2.Testing the Called SU 14
 - 5.1.5.Short Data Call Tests 15
 - 5.1.5.1.Broadcast Short Data Call Test..... 16
 - 5.1.5.2.Unit to Unit Short Data Call Test 18
 - 5.1.6.Data Call Tests 20
 - 5.1.6.1.Broadcast Data Call Test..... 20
 - 5.1.6.2.Unit to Unit Data Call Test 21
 - 5.1.7.Status Call Tests 24
 - 5.1.7.1.Broadcast Status Call Test..... 24
 - 5.1.7.2.Status Call Test 25
 - 5.1.8.Status Inquiry Tests..... 27
 - 5.1.8.1.Testing the Calling SU 27
 - 5.1.8.2.Testing the Called SU 28
 - 5.1.9.Remote Control Tests 29
 - 5.1.9.1.Testing the Calling SU 29
 - 5.1.9.2.Testing the Called SU 29
 - 5.1.10.Paging Tests 31
 - 5.1.10.1.Testing the Calling SU..... 31
 - 5.1.10.2.Testing the Called SU..... 31
 - 5.1.11.Emergency Tests 32
 - 5.1.11.1.Emergency Call..... 32
 - 5.1.11.2.Emergency Alert..... 32
 - 5.1.12.Late Entry Test 33
 - 5.1.12.1.Conference Group Call 33
 - 5.1.13.Priority Monitor Test 34
 - 5.1.14.Transmission Trunking Test..... 35
 - 5.1.15.Message Trunking Test..... 36
 - 5.1.16.Encryption Tests..... 37
 - 5.1.16.1.Encrypted Voice Call Tests..... 37

5.1.16.2.Encrypted Short Data Call Tests	37
5.1.16.3.Encrypted Data Call Tests	38
5.1.17.Registration Test	41
5.1.17.1.Registration Accept.....	41
5.1.17.2.Registration Fail.....	42
5.1.17.3.Registration Refuse.....	42
5.1.18.Registration Command Test	45
5.1.19.Registration Clear Test	45
5.1.19.1.Registration Clear Accept.....	46
5.1.19.2.Registration Clear Fail.....	46
5.1.19.3.Registration Clear Refuse	46
5.1.20.Group Registration Test	48
5.1.20.1.Group Registration Accept.....	48
5.1.20.2.Group Registration Fail.....	49
5.1.20.3.Group Registration Refuse	49
5.1.21.Authentication Tests.....	50
5.1.21.1.Authentication during Registration Process.....	50
5.1.21.2.Authentication Inquiry by Trunking Repeater	51
5.1.22.System Data Write Tests	52
5.1.22.1.System Data Write during Registration Process	52
5.1.22.2.System Data Write by Trunking Repeater.....	52
5.1.23.Site Roaming Test.....	54
5.1.24.Halt Repeater Test	55
5.1.25.ID Validation Test	55
5.2.TR Testing	56
5.2.1.Idle Message Test	56
5.2.1.1.Idle Repeater Message Test.....	56
5.2.1.2.Site ID Message Test.....	57
5.2.2.Link Tests	59
5.2.2.1.Link Accept Test.....	59
5.2.2.2.Link Refuse.....	60
5.2.2.3.Link of Traffic Repeater	60
5.2.3.Group Voice Call Tests	65
5.2.3.1.Conference Group Call Test.....	65
5.2.3.2.Broadcast Group Call Test	66
5.2.4.Individual Voice Call Tests	68
5.2.4.1.Individual Call Test	68
5.2.5.All Call Test	68
5.2.6.Short Data Call Tests	69
5.2.6.1.Broadcast Short Data Call Test.....	69
5.2.6.2.Unit to Unit Short Data Call Test	69
5.2.7.Data Call Tests	71
5.2.7.1.Broadcast Data Call Test.....	71
5.2.7.2.Unit to Unit Data Call Test	71
5.2.8.Status Call Tests	73
5.2.8.1.Broadcast Status Call Test.....	73
5.2.8.2.Individual Status Call Test	74
5.2.9.Status Inquiry Test	76
5.2.9.1.Status Inquiry Success	76

- 5.2.10.Remote Control Test78
 - 5.2.10.1.Remote Control Success 78
- 5.2.11.Emergency Test80
 - 5.2.11.1.Emergency Call.....80
 - 5.2.11.2.Emergency Alert.....80
- 5.2.12.Transmission Trunking Test.....81
- 5.2.13.Message Trunking Test.....81
- 5.2.14.Encryption Test82
- 5.2.15.Registration Test83
 - 5.2.15.1.Registration Accept.....83
- 5.2.16.Registration Command Test86
- 5.2.17.Registration Clear Test86
 - 5.2.17.1.Registration Clear Accept.....86
- 5.2.18.Group Registration Test88
 - 5.2.18.1.Group Registration Accept.....88
- 5.2.19.Authentication Tests.....89
 - 5.2.19.1.Authentication during Registration Process.....89
 - 5.2.19.2.Authentication Inquiry by Trunking Repeater90
- 5.2.20.System Data Write Tests91
 - 5.2.20.1.System Data Write during Registration Process91
 - 5.2.20.2.System Data Write by Trunking Repeater.....91
- 5.2.21.Site Roaming Test.....93
- 5.2.22.Halt Repeater Test.....94
- 5.2.23.ID Validation Test.....94
- 6.Appendix.....95
 - 6.1.Samples of Test Frame95
 - 6.1.1.Frame Data for Single Trunked System.....96
 - 6.1.1.1.Frame Data for Link.....96
 - 6.1.1.2.Frame Data for Voice Call.....98
 - 6.1.1.3.Frame Data for Short Data Call.....102
 - 6.1.1.4.Frame Data for Data Call.....106
 - 6.1.1.5.Frame Data for Status Call110
 - 6.1.1.6.Frame Data for Scramble Encrypted Voice Call.....114
 - 6.1.1.7.Frame Data for Scramble Encrypted Short Data Call.....116
 - 6.1.1.8.Frame Data for Scramble Encrypted Data Call118
 - 6.1.2.Frame Data for Multi Trunked System120
 - 6.1.2.1.Frame Data for Link.....120
 - 6.1.2.2.Frame Data for Voice Call.....122
 - 6.1.2.3.Frame Data for Short Data Call.....126
 - 6.1.2.4.Frame Data for Data Call.....130
 - 6.1.2.5.Frame Data for Status Call134
 - 6.1.2.6.Frame Data for Scramble Encrypted Voice Call.....138
 - 6.1.2.7.Frame Data for Scramble Encrypted Short Data Call.....140
 - 6.1.2.8.Frame Data for Scramble Encrypted Data Call142
- 7.Revision History.....144

Figures

Figure 5.1-1 Link Tests Setup	4
Figure 5.1-2 Short Data Call Tests Setup	15
Figure 5.1-3 Priority Monitor Test.....	34
Figure 5.1-4 Set up for SU Test.....	41
Figure 5.1-5 Site Roaming Test Setup	54
Figure 5.2-1 Idle Message Tests Setup	56
Figure 5.2-2 Link Tests Setup	59
Figure 5.2-3 Site Roaming Test Setup	93
Figure 6.1-1 Frame Structure for Link (Inbound).....	96
Figure 6.1-2 Frame Structure for Link (Outbound).....	97
Figure 6.1-3 Frame Structure for Link (Outbound).....	97
Figure 6.1-4 Frame Structure for Voice Call (Inbound).....	98
Figure 6.1-5 Frame Structure for Voice Call (Outbound).....	100
Figure 6.1-6 Frame Structure for Short Data Call (Inbound).....	102
Figure 6.1-7 Frame Structure for Short Data Call (Outbound).....	104
Figure 6.1-8 Frame Structure for Data Call (Inbound).....	106
Figure 6.1-9 Frame Structure for Data Call (Outbound).....	108
Figure 6.1-10 Frame Structure for Data Call using FACCH1 (Inbound).....	110
Figure 6.1-11 Frame Structure for Data Call using FACCH3 (Inbound).....	110
Figure 6.1-12 Frame Structure for Data Call using FACCH1 (Outbound).....	112
Figure 6.1-13 Frame Structure for Data Call using FACCH3 (Outbound).....	112
Figure 6.1-14 Frame Structure for Link (Inbound).....	120
Figure 6.1-15 Frame Structure for Link (Outbound).....	121
Figure 6.1-16 Frame Structure for Link (Outbound).....	121
Figure 6.1-17 Frame Structure for Voice Call (Inbound).....	122
Figure 6.1-18 Frame Structure for Voice Call (Outbound).....	124
Figure 6.1-19 Frame Structure for Short Data Call (Inbound).....	126
Figure 6.1-20 Frame Structure for Short Data Call (Inbound).....	128
Figure 6.1-21 Frame Structure for Data Call (Inbound).....	130
Figure 6.1-22 Frame Structure for Data Call (Outbound).....	132
Figure 6.1-23 Frame Structure for Status Call using FACCH1 (Inbound).....	134
Figure 6.1-24 Frame Structure for Status Call using FACCH3 (Inbound).....	134
Figure 6.1-25 Frame Structure for Status Call using FACCH1 (Outbound).....	136
Figure 6.1-26 Frame Structure for Status Call using FACCH3 (Outbound).....	136

Tables

Table 5.1-1 ISM INFO4 / INFO2 message.....	6
Table 5.1-2 OSM INFO4 / INFO2 (Busy Repeater Message) message	6
Table 5.1-3 OSM INFO4 / INFO2 (Free Repeater Message) message.....	7
Table 5.1-4 OSM INFO4 / INFO2 (Site ID Message Message) message.....	7

Table 5.1-5	ISM / OSM INFO4 (EOT) message.....	7
Table 5.1-6	CALL_REQ message.....	7
Table 5.1-7	CALL_CONN_RESP message.....	8
Table 5.1-8	“CALL_RESP” message.....	8
Table 5.1-9	TX_REL(Inbound) message.....	8
Table 5.1-10	TX_REL (Outbound) message.....	9
Table 5.1-11	ISM INFO3 message.....	11
Table 5.1-12	ISM INFO1 message.....	11
Table 5.1-13	OSM INFO3 message.....	11
Table 5.1-14	OSM INFO1 message.....	12
Table 5.1-15	VCALL message.....	12
Table 5.1-16	SDCALL_REQ(Header) message.....	17
Table 5.1-17	SDCALL_RESP message.....	17
Table 5.1-18	DCALL (Header) message.....	23
Table 5.1-19	DCALL_ACK message.....	23
Table 5.1-20	STAT_REQ message.....	26
Table 5.1-21	STAT_RESP message.....	26
Table 5.1-22	STAT_INQ_REQ message.....	28
Table 5.1-23	STAT_INQ_RESP message.....	28
Table 5.1-24	REM_CON_REQ message.....	30
Table 5.1-25	REM_CON_RESP message.....	30
Table 5.1-26	VCALL message (Encryption).....	39
Table 5.1-27	Encryption Tests Condition for Voice Call.....	39
Table 5.1-28	SDCALL_REQ(Header) message (Encryption).....	39
Table 5.1-29	Encryption Tests Condition for Short Data Call / Data Call.....	39
Table 5.1-30	DCALL(Header) message (Encryption).....	40
Table 5.1-31	ISM INFO4 message.....	43
Table 5.1-32	OSM INFO4 (Busy Repeater Message) message.....	43
Table 5.1-33	OSM INFO4 (Free Repeater Message) message.....	43
Table 5.1-34	OSM INFO4 / INFO2 (Site ID Message) message.....	43
Table 5.1-35	ISM / OSM INFO4 (EOT) message.....	43
Table 5.1-36	CALL_REQ message.....	43
Table 5.1-37	CALL_RESP message.....	44
Table 5.1-38	REG_REQ message.....	44
Table 5.1-39	REG_RESP message.....	44
Table 5.1-40	TX_REL (Inbound) message.....	44
Table 5.1-41	OSM INFO4 (REG_COM) message.....	45
Table 5.1-42	REG_C_REQ message.....	47
Table 5.1-43	REG_C_RESP message.....	47
Table 5.1-44	GRP_REG_REQ message.....	49
Table 5.1-45	GRP_REG_RESP message.....	49
Table 5.1-46	AUTH_INQ_REQ message.....	51
Table 5.1-47	AUTH_INQ_RESP message.....	51
Table 5.1-48	DWR (Header) message.....	53
Table 5.1-49	DWR_ACK message.....	53
Table 5.1-50	Site Parameter.....	54
Table 5.1-51	OSM INFO4 (Halt Repeater Message) message.....	55

Table 5.2-1	OSM INFO4 (Idle Repeater Message) message.....	57
Table 5.2-2	IDLE message	57
Table 5.2-3	TX_REL(Outbound) message	57
Table 5.2-4	OSM INFO4 (Site ID Message) message	58
Table 5.2-5	SRV_INFO message.....	58
Table 5.2-6	ADJ_SITE_INFO message	58
Table 5.2-7	ISM INFO4 / INFO2 message.....	61
Table 5.2-8	OSM INFO4 / INFO2 (Busy Repeater Message) message	61
Table 5.2-9	OSM INFO4 / INFO2 (Free Repeater Message) message	61
Table 5.2-10	OSM INFO4 / INFO2 (Site ID Message) message	61
Table 5.2-11	ISM / OSM INFO4 (EOT) message	62
Table 5.2-12	CALL_REQ message	62
Table 5.2-13	CALL_CONN_RESP message.....	62
Table 5.2-14	CALL_RESP message.....	63
Table 5.2-15	TX_REL(Inbound) message.....	63
Table 5.2-16	TX_REL(Outbound) message.....	64
Table 5.2-17	ISM INFO3 message.....	66
Table 5.2-18	ISM INFO1 message.....	66
Table 5.2-19	OSM INFO3 message.....	66
Table 5.2-20	OSM INFO1 message.....	66
Table 5.2-21	VCALL message.....	67
Table 5.2-22	SDCALL_REQ(Header) message	70
Table 5.2-23	SDCALL_RESP message.....	70
Table 5.2-24	DCALL(Header) message.....	72
Table 5.2-25	DCALL_ACK message	72
Table 5.2-26	STAT_REQ message.....	75
Table 5.2-27	STAT_RESP message	75
Table 5.2-28	STAT_INQ_REQ message.....	77
Table 5.2-29	STAT_INQ_RESP message.....	77
Table 5.2-30	REM_CON_REQ message	79
Table 5.2-31	REM_CON_RESP message.....	79
Table 5.2-32	VCALL message (Encryption).....	82
Table 5.2-33	ISM INFO4 message.....	83
Table 5.2-34	OSM INFO4 (Busy Repeater Message) message	83
Table 5.2-35	OSM INFO4 (Free Repeater Message) message	84
Table 5.2-36	OSM INFO4 / INFO2 (Site ID Message) message	84
Table 5.2-37	ISM / OSM INFO4 (EOT) message.....	84
Table 5.2-38	CALL_REQ message	84
Table 5.2-39	CALL_RESP message.....	84
Table 5.2-40	REG_REQ message.....	84
Table 5.2-41	REG_RESP message	85
Table 5.2-42	TX_REL (Inbound) message	85
Table 5.2-43	TX_REL (Outbound) message.....	85
Table 5.2-44	REG_C_REQ message.....	87
Table 5.2-45	REG_C_RESP message	87
Table 5.2-46	GRP_REG_REQ message.....	88
Table 5.2-47	GRP_REG_RESP message	88

Table 5.2-48 AUTH_INQ_REQ message.....90
Table 5.2-49 AUTH_INQ_RESP message90
Table 5.2-50 DWR (Header) message.....92
Table 5.2-51 DWR_ACK message.....92
Table 5.2-52 Site Parameter93
Table 6.1-1 IDs Setup for Sample Frame Data.....95
Table 6.1-2 Encryption Setup for Sample Frame Data95
Table 6.1-3 Packet Information for Short Data Call..... 102
Table 6.1-4 Packet Information for Data Call..... 106
Table 6.1-5 Packet Information for Short Data Call..... 126
Table 6.1-6 Packet Information for Data Call..... 130

Disclaimer

The information presented here is intended to be for clarification and/or information purpose only, and care has been taken to keep the contents as neutral and accurate as possible.

The use or practice of contents of the information may involve the use of intellectual property rights ("IPR"), including pending or issued patents, or copyrights, owned by one or more parties. The NXDN Forum makes no search or investigation for IPR, nor the NXDN Forum makes no arrangement of licensing negotiation for IPR between the user and the owner of IPR.

All warranties, express or implied, are disclaimed, including without limitation, any and all warranties concerning the accuracy of the contents, its fitness or appropriateness for a particular purpose or use, its merchantability and its non-infringement of any third party's IPR.

The NXDN Forum expressly disclaims any and all responsibilities for the accuracy of the contents and makes no representations or warranties regarding the content's compliance with any applicable statute, rule or regulation.

The NXDN Forum shall not be liable for any and all damages, direct or indirect, arising from or relating to any use of the contents contained herein, including without limitation any and all indirect, special, incidental or consequential damages (including damages for loss of business, loss of profits, litigation, or the like), whether based upon breach of contract, breach of warranty, tort (including negligence), product liability or otherwise, even if advised of the possibility of such damages.

The foregoing negation of damages is a fundamental element of the use of the contents hereof, and these contents would not be published by the NXDN Forum without such limitations.

Document Copyrights

This document is copyrighted by JVC KENWOOD Corporation and Icom Incorporated ("copyright holder"). No duplication, alteration or distribution of this document or any portion thereof shall take place without the express permission of the copyright holder except downloading from the NXDN Forum worldwide web. Reproduction, distribution, or transmission for any purpose in any form or by any means, electronic or mechanical, shall only be allowed with the express permission of the copyright holder.

Trademarks

NXDN[®] is a registered trademark of Icom Incorporated and JVC KENWOOD Corporation. AMBE+2[™] is a trademark of Digital Voice Systems, Inc.

1. Introduction

This test specification provides a test procedure and determination criteria for trunking operations interoperability for radio equipment designed in accordance with Air Interface specifications of NXDN Type-D (Distributed Logic Trunked System).

This interoperability testing enables verification of interoperability among radio equipment manufactured by different manufacturers, or among different radio equipment manufactured by the same manufacturer, or of radio equipment of which the firmware is updated.

Defining test items for all of functions and conditions defined in the Air Interface specifications results in an enormous amount of documents and is unrealistic. Additionally defining the test procedures and related determination criteria for the system dependent functions is difficult. Hence, test items presented in this document do not contain all of functions and conditions and are limited to the scope that enables guarantee of a minimum interoperability. As well as conducting test items described in this document, it is recommended that every radio manufacturer verifies that radio equipment including items undefined by this document are in conformity with the NXDN specifications by conducting more detailed testing by referring to the Air Interface specifications.

The Common Air Interface Test as presented in REF [3] shall take place prior to this testing.

2. References

Reference documents are listed below.

REF [1]	Part 1-E Common Air Interface (Type-D)
REF [2]	Part 1-F Trunking Procedures
REF [3]	Part 2-B Common Air Interface Test
REF [4]	Part 2-C Basic Operation Test

3. Abbreviations

To help understand this document, abbreviations are listed below.

CAI	Common Air Interface
FACCH1	Fast Associated Control Channel 1
FACCH3	Fast Associated Control Channel 3
FSW	Frame Sync Word
ISM	Inbound Signaling Message
LICH	Link Information Channel
OSM	Outbound Signaling Message
RTCH2	RF Traffic Channel 2
RU	Repeater Unit
SCCH	Signaling Control Channel
SU	Subscriber Unit
TC	Trunking Controller
TR	Trunking Repeater
TRS	Trunking Repeater Site
UDCH2	User Data Channel 2
USC	User Specific Channel
VCH	Voice Channel

4. Outline

There are two types of test methods available for interoperability testing of trunking operation as below:

Method 1: A method where an SU (or a TR) to be tested is tested by an interoperability tester

Method 2: A method where a testing takes place between an SU and TR

Method 1 is a test method using an interoperability tester. By verifying that the unit under test conforms to the specifications specified in Common Air Interface of the REF [1] and in Trunking Procedures of the REF [2], method 1 indirectly verifies that the unit under test has interoperability with other radio equipment which also conforms to the specifications. Method 2 is a test method under the actual operation condition. This method allows testing without using an interoperability tester required by Method 1. If neither SU nor TR that has been verified in accordance with this document is available, both SU and TR shall be treated as units under test. Therefore, in the event that any test item fails, it is essential to specify which has nonconformity, either SU or TR. Also, even if a test item passes, it is necessary to fully verify that both SU and TR are in conformity with the specifications specified in REF [1] and REF [2].

A configuration diagram for testing is described in the configuration for Method 1; however, unless otherwise specified, either of two test methods can be employed. Configuration of an interoperability tester is not specified in this document; hence, the configuration shall be prepared using an appropriate method by the respective manufacturer that performs the test.

5. Test Procedures

In this section, test methods and judging criteria are presented.

Test methods for all functions are not described in this document. Functions not specified in this document shall be tested by the respective manufacturer using an appropriate test method.

Each test method shall verify that the contents of messages exchanged between an SU and TR are correct and the SU and TR behave according to proper procedure upon transmit or receipt of these messages.

A way of checking the data string of the layer 3 message is not specified in this document. For example, it can be verified by outputting the received log data from a unit under test or interoperability tester, or by preparing a monitoring receiver which can receive both inbound signals from the unit under test and outbound signals from the interoperability tester.

Unless otherwise specified, the receive signal input level of the unit under test shall be -47 dBm or shall be equal to a significantly high level.

The data string is, in principle, described in the hexadecimal format; however, the letter "b" shall be suffixed in the case that the data string is described in the binary format.

In the transmit sequence of a data string, transmission begins with the leftmost value, and the rightmost value is sent at the end.

The setting values of Source ID and Destination ID used by tests are not defined in particular, so they can be selected in the range specified in REF [1].

A Tone Test Pattern or actual audio signals can be applied to the voice signals to be used for voice call testing. Contents of User Data to be used for data call testing are arbitrary.

5.1. SU Testing

5.1.1. Link Tests

In this test, we evaluate the validity of the description of the messages used in Link establishment operation prior to other operations including Call, and verify whether or not SU operates as intended in response to those messages.

The connection configuration of this test is shown in Figure 5.1-1. Suppose a calling SU as SU No.1, a called SU as SU No.2.

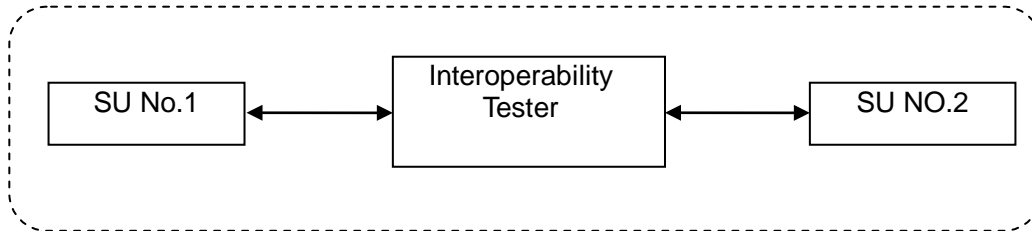

Figure 5.1-1 Link Tests Setup

Following 10 varieties of messages will be used.

Table 5.1-1 : ISM INFO4 / INFO2 messages

Table 5.1-2 : OSM INFO4 / INFO2 (Busy Repeater Message) message

Table 5.1-3 : OSM INFO4 / INFO2 (Free Repeater Message) message

Table 5.1-4 : OSM INFO4 / INFO2 (Site ID Message Message) message

Table 5.1-5 : ISM / OSM INFO4 (EOT) message

Table 5.1-6 : CALL_REQ message from SU

Table 5.1-7 : CALL_CONN_RESP message from Interoperability Tester

Table 5.1-8 : CALL_RESP message from Interoperability Tester

Table 5.1-9 : TX_REL(Inbound) message from SU

Table 5.1-10 : TX_REL(Outbound) message from an Interoperability Tester

5.1.1.1. Link Accept Test

This Section shows the case in which a link is established successfully.

5.1.1.1.1. Calling SU

- (1) Turn the power of SU No.1 ON, and make this SU be in an idle (transmitting) mode.
- (2) Transmit a message "OSM INFO4 / INFO2" (Free Repeater Message) shown in Table 5.1-3 from Interoperability Tester, whereby informs the SU that the Home repeater for the SU is Free Repeater.
- (3) When a PTT switch of SU No.1 is turned ON, verify that TR on Home Repeater transmits "CALL_REQ" message shown in Table 5.1-6 that includes "INFO4" message shown in Table 5.1-1 in SCCH.
- (4) When a message "CALL_CONN_RESP" shown in Table 5.1-7 indicating "a queue not specifying any other cause" that includes any of "INFO4" messages shown in Table 5.1-2 to Table 5.1-4 in SCCH has been transmitted from an Interoperability Tester, verify that the SU becomes an idle mode.
- (5) When a "CALL_RESP" message shown in Table 5.1-8 that includes "INFO4" message shown in Table 5.1-2 has been transmitted from Interoperability Tester to SCCH, verify that SU No.1 starts operations such as Call.

5.1.1.1.2. Called SU

- (1) Turn the power of SU No.2 ON, and make this SU be in an idle (receiving) mode.

- (2) When a message "CALL_CONN_RESP" shown in Table 5.1-7 indicating "a queue not specifying any other cause" that includes any of "INFO4" messages shown in Table 5.1-2 to Table 5.1-4 in SCCH has been transmitted from an Interoperability Tester, verify that the SU, verify that the SU remains to be an idle mode.
- (3) When a "CALL_RESP" message shown in Table 5.1-8 that includes "INFO4" message shown in Table 5.1-2 has been transmitted from Interoperability Tester to SCCH, verify that SU No.2 becomes standby mode for receiving any Messages including "Call" which will be transmitted subsequently.

5.1.1.2. Link Refuse

This Section shows the case in which link establishment is rejected.

5.1.1.2.1. Calling SU

- (1) Turn the SU No. 1 ON and keep it in the idle state.
- (2) Transmit a message "OSM INFO4 / INFO2" (Free Repeater Message) shown in Table 5.1-3 from Interoperability Tester, whereby informs the SU that the Home repeater for the SU is Free Repeater.
- (3) When a PTT switch of SU No.1 is turned ON, verify that TR on Home Repeater transmits "CALL_REQ" message shown in Table 5.1-6 that includes "INFO4" message shown in Table 5.1-1 to SCCH.
- (4) When a message "TX_REL(Outbound)" indicating that the communication permission request is "refused" shown in Table 5.1-7 that includes any one of "INFO4 (EOT)" messages shown in Table 5.1-2 to Table 5.1-4 in SCCH has been transmitted from an Interoperability Tester, verify that SU No.1 transmits "TX_REL (Inbound)" message shown in Table 5.1-9 that includes "INFO4 (EOT)" message shown in Table 5.1-5, and shifts its channel frequency to the channel frequency of the Home repeater.

5.1.1.2.2. Called SU

- (1) Turn the SU No. 2 ON and keep it in the idle state.
- (2) When a message "CALL_CONN_RESP" shown in Table 5.1-7 indicating "refused" that includes any of "INFO4" messages shown in Table 5.1-2 to Table 5.1-4 in SCCH has been transmitted from an Interoperability Tester, verify that the SU, verify that the SU remains to be an idle mode.
- (3) When a message "TX_REL(Outbound)" shown in
- (4) Table 5.1-10 that includes "INFO4 (EOT)" message shown in Table 5.1-5 has been transmitted from an Interoperability Tester, verify that SU No.2 remains to be in the idle mode.

5.1.1.3. Link of Traffic Repeater

This Section shows a test method in which Link operation is performed via any of repeaters other than the Home repeater.

5.1.1.3.1. Calling SU

- (1) Turn the SU No. 1 ON and keep it in the idle state.
- (2) Transmit a message "OSM INFO4 / INFO2" (Free Repeater Message) shown in Table 5.1-3 from Interoperability Tester, whereby informs the SU that the non-Home repeater for the SU is Free Repeater.
- (3) When a PTT switch of SU No.1 is turned ON, verify that the SU transmits a "CALL_REQ" message shown in Table 5.1-6 that includes a "INFO4" message shown in Table 5.1-1 to SCCH, and changes its channel frequency to that of Free Repeater instructed at step (1) that is not the Home Repeater of the SU.
- (4) When a message "CALL_CONN_RESP" shown in Table 5.1-7 indicating "a queue not specifying any other cause" that includes any of "INFO4" messages shown in Table 5.1-2 to Table 5.1-4 in SCCH has been transmitted from an Interoperability Tester, verify that the SU becomes an idle mode.
- (5) When a "CALL_RESP" message shown in Table 5.1-8 which includes "INFO4" message shown in Table 5.1-2 in SCCH from Interoperability Tester, verify that the SU No.1 shifts its channel frequency to that of the communication channel.

5.1.1.3.2. Called SU

- (1) Turn the SU No. 1 ON and keep it in the idle state.
- (2) When "OSM INFO4 / INFO2" (Busy Repeater Message) shown in Table 5.1-2 has been transmitted from an Interoperability Tester, verify that the SU No.2 shifts its channel frequency to the channel frequency of the non-Home repeater, and then, becomes standby mode for receiving any Messages including "Call" which will be transmitted subsequently.

Table 5.1-1 ISM INFO4 / INFO2 message

	Single Trunked System	Multi Trunked System
Structure	00b (INFO4) 10b (INFO2)	
Area	Value of Area	
Repeater in Use	Value of Use Repeater number	
Destination	Home Repeater Value of Home Repeater number	Destination Prefix Value of Destination Prefix
	Group ID (Group Call) Unit ID of SU No.2 (Individual Call) ID=7FF (All Call)	
G/U	Group=0b/Unit=1b (Destination ID)	

Table 5.1-2 OSM INFO4 / INFO2 (Busy Repeater Message) message

	Single Trunked System	Multi Trunked System
Structure	00b (INFO4) 10b (INFO2)	
Area	Value of Area	
Go to Repeater	Value of Go to Repeater number	
Destination	Home Repeater Value of Home Repeater number	Destination Prefix Value of Destination Prefix
	Group ID (Group Call) Unit ID of SU No.2 (Individual Call) ID=7FF (All Call)	
G/U	Group=0b/Unit=1b (Destination ID)	

Table 5.1-3 OSM INFO4 / INFO2 (Free Repeater Message) message

	Single Trunked System	Multi Trunked System
Structure	00b (INFO4) 10b (INFO2)	
Area	Value of Area	
Free Repeater1	Value of Free Repeater number (NOTE: use a channel frequency which is idle for communication)	
Free Repeater2	Value of Free Repeater number (NOTE: use a channel frequency which is idle for communication)	
ID	7FC	

Table 5.1-4 OSM INFO4 / INFO2 (Site ID Message Message) message

	Single Trunked System	Multi Trunked System
Structure	-	00b (INFO4) 10b (INFO2)
Area	-	Value of Area
Site Type	-	Value of Site Type
Site Code	-	Value of Site Code
ID	-	7F9

Table 5.1-5 ISM / OSM INFO4 (EOT) message

	Single Trunked System	Multi Trunked System
Structure	00b (INFO4) 10b (INFO2)	
Area	Value of Area	
Repeater in Use / Go to Repeater	11111b	
Destination	Home Repeater Value of Home Repeater number Group ID (Group Call) Unit ID of SU No.2 (Individual Call) ID=7FF (All Call)	Destination Prefix Value of Destination Prefix
G/U	Group=0b/Unit=1b (Destination ID)	

Table 5.1-6 CALL_REQ message

	Single Trunked System	Multi Trunked System
CC Option	00 (Individual Call, Group Call, All Call) 80 (Emergency Call)	10 (Individual Call, Group Call, All Call) 90 (Emergency Call)
Call Type	100b (Individual Call) 001b (Conference Group Call / All Call) 000b (Broadcast Call)	
Source	Home Repeater Value of Home Repeater number Unit ID of SU No.1	Source Prefix Value of Source Prefix
Destination	Home Repeater Value of Home Repeater number Group ID (Group Call) Unit ID of SU No.2 (Individual Call) ID=7FF (All Call)	Destination Prefix Value of Destination Prefix
System ID Option	-	10000b / 01000b
System ID	-	Value of System ID

Table 5.1-7 CALL_CONN_RESP message

	Single Trunked System	Multi Trunked System
CC Option	00 (Individual Call, Group Call, All Call) 80 (Emergency Call)	10 (Individual Call, Group Call, All Call) 90 (Emergency Call)
Call Type	100b (Individual Call) 001b (Conference Group Call / All Call) 000b (Broadcast Call)	
Source	Home Repeater Value of Home Repeater number	Source Prefix Prefix of SU No.1
	Unit ID of SU No.1	
Destination	Home Repeater Value of Home Repeater number	Destination Prefix Value of Destination Prefix
	Group ID (Group Call) Unit ID of SU No.2 (Individual Call) ID=7FF (All Call)	
Cause (VD)	0111111b (a queue not specifying any other cause) 0010010b (a service of a calling SU is not allowed.)	
System ID Option	-	10000b / 01000b
System ID	-	Value of System ID

Table 5.1-8 "CALL_RESP" message

	Single Trunked System	Multi Trunked System
CC Option	00 (Individual Call, Group Call, All Call) 80 (Emergency Call)	10 (Individual Call, Group Call, All Call) 90 (Emergency Call)
Call Type	100b (Individual Call) 001b (Conference Group Call / All Call) 000b (Broadcast Call)	
Free Repeater	Any value in the range of 00001b-11110b	
Source	Home Repeater Value of Home Repeater number	Source Prefix Prefix of SU No.1
	Unit ID of SU No.1	
Destination	Home Repeater Value of Home Repeater number	Destination Prefix Value of Destination Prefix
	Group ID (Group Call) Unit ID of SU No.2 (Individual Call) ID=7FF (All Call)	
System ID Option	-	10000b / 01000b
System ID	-	Value of System ID

Table 5.1-9 TX_REL(Inbound) message

	Single Trunked System	Multi Trunked System
CC Option	00 (Individual Call, Group Call, All Call) 80 (Emergency Call)	10 (Individual Call, Group Call, All Call) 90 (Emergency Call)
Call Type	100b (Individual Call) 001b (Conference Group Call / All Call) 000b (Broadcast Call)	
Source	Home Repeater Value of Home Repeater number	Source Prefix Prefix of SU No.1
	Unit ID of SU No.1	
Destination	Home Repeater Value of Home Repeater number	Destination Prefix Value of Destination Prefix
	Group ID (Group Call) Unit ID of SU No.2 (Individual Call) ID=7FF (All Call)	

Table 5.1-10 TX_REL (Outbound) message

	Single Trunked System	Multi Trunked System
CC Option	00 (Individual Call, Group Call, All Call) 80 (Emergency Call)	10 (Individual Call, Group Call, All Call) 90 (Emergency Call)
Call Type	100b (Individual Call) 001b (Conference Group Call / All Call) 000b (Broadcast Call)	
Free Repeater	Any value in the range of 00001b-11110b	
Source	Home Repeater Value of Home Repeater number	Source Prefix Prefix of SU No.1
	Unit ID of SU No.1	
Destination	Home Repeater Value of Home Repeater number	Destination Prefix Value of Destination Prefix
	Group ID (Group Call) Unit ID of SU No.2 (Individual Call) ID=7FF (All Call)	

5.1.2. Group Voice Call Tests

This test shall verify that contents of messages used for Group Voice Call are correct, that the unit under test correctly responds to these messages, and that a receiving unit outputs normal received audio signal.

This test includes the test methods for the following two modes:

- (1) Conference Group Call
- (2) Broadcast Group Call

Figure 5.1-1 shows the configuration diagram for testing. SU No. 1 and SU No. 2 shall be tested as the calling unit and the called unit respectively.

The following 15 types of messages shall be applied.

- Table 5.1-1 : ISM INFO4 / INFO2 messages
- Table 5.1-2 : OSM INFO4 / INFO2 (Busy Repeater Message) message
- Table 5.1-3 : OSM INFO4 / INFO2 (Free Repeater Message) message
- Table 5.1-4 : OSM INFO4 / INFO2 (Site ID Message Message) message
- Table 5.1-5 : ISM / OSM INFO4 (EOT) message
- Table 5.1-6 : CALL_REQ message from SU
- Table 5.1-7 : CALL_CONN_RESP message from Interoperability Tester
- Table 5.1-8 : CALL_RESP message from Interoperability Tester
- Table 5.1-9 : TX_REL(Inbound) message from SU
- Table 5.1-10 : TX_REL(Outbound) message from an Interoperability Tester
- Table 5.1-11 : ISM INFO3 message
- Table 5.1-12 : ISM INFO1 message
- Table 5.1-13 : OSM INFO3 message
- Table 5.1-14 : OSM INFO1 message
- Table 5.1-15 : VCALL message from SU

5.1.2.1. Conference Group Call Test

In this test, parameters for messages to be used shall apply the values for Conference Group Call.

5.1.2.1.1. Testing the Calling SU

5.1.2.1.1.1. Group Call Success

- (1) Link connection will be shown in Section 5.1.1.
- (2) When "CALL_RESP" message shown in Table 5.1-8 has been transmitted from an Interoperability Tester, verify that the called SU sends a "VCALL" message shown in Table 5.1-815 which includes "INFO4" message shown in Table 5.1-1 to SCCH.
- (3) Verify that the called SU sends a vocal data(VCH) after transmitting a VCALL message. Be sure that SCCH sequentially includes INFO1 to INFO4 messages shown in Table 5.1-1, Table 5.1-11 and Table 5.1-12, respectively.
- (4) After a PTT switch has been released, verify that the called SU transmits a "TX_REL(Inbound)" message shown in Table 5.1-9 that includes "INFO4 (EOT)" message shown in Table 5.1-5.
- (5) After a final frame that includes "TX_REL" message has been transmitted at step (4), verify that the SU ends the transmission, and returns its channel frequency to the channel frequency of the Home repeater.

5.1.2.1.2. Testing the Called SU

- (1) Turn the SU No. 2 ON and keep it in the idle state.

- (2) When a "VCALL" message shown in Table 5.1-15 that includes any of "INFO4" messages shown in Table 5.1-2 to Table 5.1-4 in SCCH, and vocal data(VCH) that sequentially includes any of "INFO4 / INFO2" messages shown in Table 5.1-2 to Table 5.1-4, "INFO3" shown in Table 5.1-13, and "INFO1" shown in Table 5.1-14, verify that SU No.2 remains to be in the channel frequency of the Home Repeater, and becomes a receiving mode.

The procedural steps to follow when including Busy Repeater Message shown in Table 5.1-2, Free Repeater Message shown in Table 5.1-3 and Site ID Message shown in Table 5.1-4 on "INFO2" and "INFO4" messages will not be stipulated.

- (3) Verify that SU No. 2 outputs normal received audio signal when an interoperability tester makes a voice call transmission.
- (4) When a "TX_REL(Outbound)" message shown in
- (5) Table 5.1-10 that includes "INFO4 (EOT)" message shown in Table 5.1-5 has been transmitted from an Interoperability Tester, verify that the SU removes vocals timely and shifts its channel frequency to the channel frequency of the Home repeater.

Table 5.1-11 ISM INFO3 message

	Single Trunked System	Multi Trunked System
Structure	01b	
Area	Value of Area	
Repeater in Use	Value of Use Repeater number	
Source	Home Repeater	Source Prefix
	Value of Home Repeater number Unit ID of SU No.1	Prefix of SU No.1

Table 5.1-12 ISM INFO1 message

	Single Trunked System	Multi Trunked System
Structure	11b	
Area	Value of Area	
Repeater in Use	Value of Use Repeater number	
Pass Character	11111b	
Call Option	000b (Individual Call, Group Call, All Call) 100b (Emergency Call)	010b (Individual Call, Group Call, All Call) 110b (Emergency Call)
Cipher Type	00b	
Key ID	000000b	

Table 5.1-13 OSM INFO3 message

	Single Trunked System	Multi Trunked System
Structure	01b	
Area	Value of Area	
Free Repeater1	Value of Free Repeater number	
Source	Home Repeater	Source Prefix
	Value of Home Repeater number Unit ID of SU No.1	Prefix of SU No.1

Table 5.1-14 OSM INFO1 message

	Single Trunked System	Multi Trunked System
Structure	11b	
Area	Value of Area	
Free Repeater1	Value of Free Repeater number	
Free Repeater2	Value of Free Repeater number	
Call Option	000b (Individual Call, Group Call, All Call) 100b (Emergency Call)	010b (Individual Call, Group Call, All Call) 110b (Emergency Call)
Cipher Type	00b	
Key ID	000000b	

Table 5.1-15 VCALL message

	Single Trunked System	Multi Trunked System
CC Option	00 (Individual Call, Group Call, All Call) 80 (Emergency Call)	10 (Individual Call, Group Call, All Call) 90 (Emergency Call)
Call Type	100b (Individual Call) 001b (Conference Group Call / All Call) 000b (Broadcast Call)	
Source	Home Repeater Value of Home Repeater number Unit ID of SU No.1	Source Prefix Prefix of SU No.1
Destination	Home Repeater Value of Home Repeater number Group ID (Group Call) Unit ID of SU No.2 (Individual Call) ID=7FF (All Call)	Destination Prefix Value of Destination Prefix
Cipher Type	00b	
Key ID	000000b	

5.1.2.2. Broadcast Group Call Test

In this test, parameters for messages to be used shall apply the values for Broadcast Group Call.

Tests for the calling SU shall be identical to those specified in Section 5.1.2.1.1 and tests for the called SU shall be identical to those specified in Section 5.1.2.1.2.

5.1.3. Individual Voice Call Tests

This test shall verify that contents of messages used for Individual Voice Call are correct that the unit under test correctly responds to these messages, and that a receiving unit outputs normal received audio signal.

Figure 5.1-1 shows the configuration diagram for testing. SU No. 1 and SU No. 2 shall be tested as the calling unit and the called unit respectively.

The following 15 types of messages shall be applied.

- Table 5.1-1 : ISM INFO4 / INFO2 message
- Table 5.1-2 : OSM INFO4 / INFO2 (Busy Repeater Message) message
- Table 5.1-3 : OSM INFO4 / INFO2 (Free Repeater Message) message
- Table 5.1-4 : OSM INFO4 / INFO2 (Site ID Message Message) message
- Table 5.1-5 : ISM / OSM INFO4 (EOT) message
- Table 5.1-6 : ALL_REQ message from SU
- Table 5.1-7 : CALL_CONN_RESP message from Interoperability Tester
- Table 5.1-8 : CALL_RESP message from Interoperability Tester
- Table 5.1-9 : TX_REL(Inbound) SU from SU
- Table 5.1-10 : TX_REL(Outbound) message from Interoperability
- Table 5.1-11 : ISM INFO3 message
- Table 5.1-12 : ISM INFO1 message
- Table 5.1-13 : OSM INFO3 message
- Table 5.1-14 : OSM INFO1 message
- Table 5.1-15 : VCALL message from SU

Values for Individual Call shall be applied to parameters for each Table.

5.1.3.1. Individual Call Test

5.1.3.1.1. Testing the Calling SU

5.1.3.1.1.1. Individual Call Success

Testing Procedures for these five cases shall be identical to those tests for Conference Group Call as described in Section 5.1.2.1.1.

5.1.3.1.1.2. Testing the Called SU

Testing Procedures shall be identical to those tests for Conference Group Call as described in Section 5.1.2.1.2.

5.1.4. All Call Tests

This test shall verify that contents of messages used for All Call are correct, that the unit under test correctly responds to these messages, and that receiving unit outputs normal received audio signal.

Figure 5.1-1 shows the configuration diagram for testing. SU No. 1 and SU No. 2 shall be tested as the calling unit and the called unit respectively.

The following 15 types of messages shall be applied.

- Table 5.1-1 : ISM INFO4 / INFO2 message
- Table 5.1-2 : OSM INFO4 / INFO2 (Busy Repeater Message) message
- Table 5.1-3 : OSM INFO4 / INFO2 (Free Repeater Message) message
- Table 5.1-4 : OSM INFO4 / INFO2 (Site ID Message Message) message
- Table 5.1-5 : ISM / OSM INFO4 (EOT) message
- Table 5.1-6 : CALL_REQ message from SU
- Table 5.1-7 : CALL_CONN_RESP message from Interoperability Tester
- Table 5.1-8 : CALL_RESP from Interoperability Tester
- Table 5.1-9 : TX_REL(Inbound) message from SU
- Table 5.1-10 : TX_REL(Outbound) message from Interoperability Tester
- Table 5.1-11 : ISM INFO3 message
- Table 5.1-12 : ISM INFO1 message
- Table 5.1-13 : OSM INFO3 message
- Table 5.1-14 : OSM INFO1 message
- Table 5.1-15 : VCALL message from SU

Values for All Call shall be applied to parameters for each Table.

5.1.4.1. Testing the Calling SU

5.1.4.1.1. All Call Success

Testing Procedures for this case shall be identical to those tests for Conference Group Call as described in Section 5.1.2.1.1.

5.1.4.2. Testing the Called SU

Testing Procedures shall be identical to those tests for Conference Group Call as described in Section 5.1.2.1.2.

5.1.5. Short Data Call Tests

This test shall verify that contents of messages used for Short Data Call are correct, that the unit under test correctly responds to these messages, and that the called unit outputs normal received data.

This test includes the test methods for the following two modes.

- (1) Broadcast Short Data Call
- (2) Unit to Unit Short Data Call

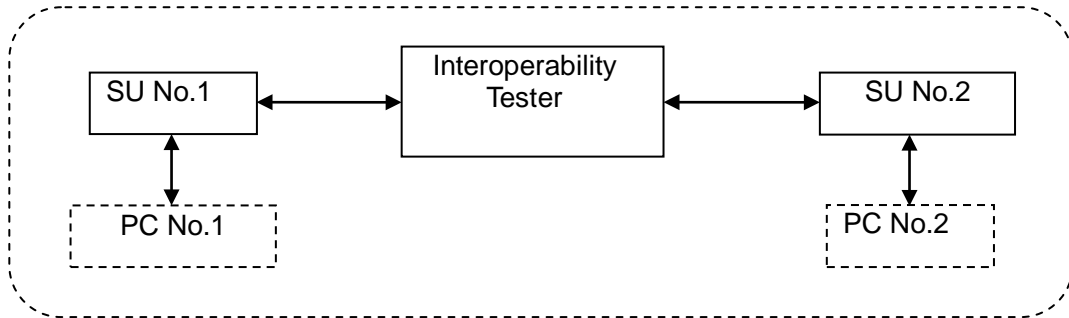

Figure 5.1-2 Short Data Call Tests Setup

Figure 5.1-2 shows the configuration diagram for testing. In the event that an SU by itself cannot realize the Short Data Call functions, testing can be done by connecting peripheral equipment such as a PC to the SU.

The following 12 types of messages shall be applied.

Table 5.1-1 : ISM INFO4 / INFO2 message

Table 5.1-2 : OSM INFO4 / INFO2 (Busy Repeater Message) message

Table 5.1-3 : OSM INFO4 / INFO2 (Free Repeater Message) message

Table 5.1-4 : OSM INFO4 / INFO2 (Site ID Message Message) message

Table 5.1-5 : ISM / OSM INFO4 (EOT) message

Table 5.1-6 : CALL_REQ message from SU

Table 5.1-7 : CALL_CONN_RESP message from Interoperability Tester

Table 5.1-8 : CALL_RESP message from Interoperability Tester

Table 5.1-9 : TX_REL(Inbound) message from SU

Table 5.1-10 : TX_REL(Outbound) message from Interoperability Tester

Table 5.1-16 : SDCALL_REQ(Header) message

Table 5.1-17 : SDCALL_RESP message

SDCALL_REQ (User Data) messages are recommended to be constructed with User Data not exceeding 100 bytes. No contents of User Data are specified in this document.

5.1.5.1. Broadcast Short Data Call Test

In this test, parameters for messages to be used shall apply the values for Group Call.

5.1.5.1.1. Testing the Calling SU

5.1.5.1.1.1. Short Data Success

- (1) Link connection will be shown in Section 5.1.1.
- (2) When SU No.1 has started "Short Data Call", verify that the SU transmits a "SDCALL_REQ(Header)" message shown in Table 5.1-16 that includes "INFO4" message shown in Table 5.1-1 in SCCH, and "SDCALL_REQ(User Data)" message.
- (3) After transmitting (2) abovementioned messages, verify that the SU transmits a "TX_REL(Inbound)" message shown in Table 5.1-9 that includes "INFO4 (EOT)" message shown in Table 5.1-5, and shifts its channel frequency to the channel frequency of the Home repeater.

5.1.5.1.2. Testing the Called SU

- (1) SU No.2 shifts its frequency channel based on the procedure shown in Section 5.1.1.
- (2) When a "SDCALL_REQ(Header)" message shown in Table 5.1-16 that includes any of "INFO4" message shown in Table 5.1-2 to Table 5.1-4 in SCCH, "SDCALL_REQ(User Data)" message, and "TX_REL(Outbound)" message shown in
- (3) Table 5.1-10 that includes "INFO4 (EOT)" message shown in Table 5.1-5 have been transmitted from an Interoperability Tester, verify that SU No.2 receives User Data properly and shifts its channel frequency to the channel frequency of the Home repeater.

Table 5.1-16 SDCALL_REQ(Header) message

	Single Trunked System	Multi Trunked System
CC Option	00	10
Call Type	100b (Individual Call) 001b (Group Call)	
Source	Home Repeater Value of Home Repeater number	Source Prefix Prefix of SU No.1
	Unit ID of SU No.1	
Destination	Home Repeater Value of Home Repeater number	Destination Prefix Value of Destination Prefix
	Unit ID of SU No.2 (Individual Call) Group ID (Group Call)	
Cipher Type	00b	
Key ID	000000b	
Packet Information	Except for the following, depends on the format to be used for testing. Delivery Flag = 0 (Group Call, Individual Call) Unconfirmed Delivery Flag = 1 (Individual Call) Confirmed	

Table 5.1-17 SDCALL_RESP message

	Single Trunked System	Multi Trunked System
CC Option	00	10
Call Type	100b	
Source	Home Repeater Value of Home Repeater number	Source Prefix Prefix of SU No.2
	Unit ID of SU No.2	
Destination	Home Repeater Value of Home Repeater number	Destination Prefix Value of Destination Prefix
	Unit ID of SU No.1	
Cause (SS)	01 (Receive Success) / 08 (Full Retry)	
Error Block Flag	Depends on the format to be used for testing.	

5.1.5.2. Unit to Unit Short Data Call Test

In this test, parameters for messages to be used shall apply the values for Individual Call. The procedure for Unit to Unit Short Data Call is different between Confirmed format and Unconfirmed format.

To verify the interoperability, a unit under test shall pass the test item for at least either of the Confirmed format or the Unconfirmed format.

In the case of the Confirmed format, a unit under test shall pass the test items specified in Section 5.1.5.2.1.1 and Section 5.1.5.2.2.1.

In the case of the Unconfirmed format, a unit under test shall pass the test items specified in Section 5.1.5.2.1.2 and Section 5.1.5.2.2.2.

5.1.5.2.1. Testing the Calling SU

5.1.5.2.1.1. Short Data Success - (Confirmed)

- (1) Link connection will be shown in Section 5.1.1.
- (2) When SU No.1 has started "Short Data Call", verify that the SU transmits a "SDCALL_REQ(Header)" message shown in Table 5.1-16 that includes "INFO4" message shown in Table 5.1-1 in SCCH, and "SDCALL_REQ(User Data)" message.
- (3) When a "SDCALL_RESP" message shown in Table 5.1-17 indicating Receive Success that include any of INFO4 messages shown in Table 5.1-2 to Table 5.1-4 (the instructed Destination is SU No.1) in SCCH has been transmitted from an Interoperability Tester, verify that SU No.1 transmits "TX_REL(Inbound)" shown in Table 5.1-9 that includes "INFO4(EOT)" message shown in Table 5.1-5, and shifts its channel frequency to the channel frequency of the Home repeater.

5.1.5.2.1.2. Short Data Success - (Unconfirmed)

- (1) Link connection will be shown in Section 5.1.1.
- (2) When SU No.1 has started "Short Data Call", verify that the SU transmits a "SDCALL_REQ(Header)" message shown in Table 5.1-16 that includes "INFO4" message shown in Table 5.1-1 in SCCH, "SDCALL_REQ(User Data)" message, and "TX_REL(Inbound)" shown in Table 5.1-9 that includes "INFO4(EOT)" message shown in Table 5.1-5, and shifts its channel frequency to the channel frequency of the Home repeater.

5.1.5.2.1.3. Full Retry

Testing procedures for this case shall be common to the Confirmed format and Unconfirmed format, as follow:

- (1) Link connection will be shown in Section 5.1.1.
- (2) When SU No.1 has started "Short Data Call", verify that the SU transmits a "SDCALL_REQ(Header)" message shown in Table 5.1-16 that includes "INFO4" message shown in Table 5.1-1 in SCCH, and "SDCALL_REQ(User Data)" message.
- (3) When a "SDCALL_RESP" message shown in Table 5.1-17 indicating re-transmission of all the messages that include any of "INFO4" messages shown in Table 5.1-2 to Table 5.1-4 (the instructed Destination is SU No.1) in SCCH has been transmitted by using an Interoperability Tester, verify that the SU No.1 transmits a "SDCALL_REQ(Header)" message shown in Table 5.1-16 that includes "INFO4" message shown in Table 5.1-1, and "SDCALL_REQ(User Data)" message to SCCH.

5.1.5.2.2. Testing the Called SU

5.1.5.2.2.1. Receive Success - (Confirmed)

- (1) SU No.2 shifts its frequency channel based on the procedure shown in Section 5.1.1.
- (2) When a "SDCALL_REQ(Header)" message shown in Table 5.1-16 that includes any of "INFO4" message shown in Table 5.1-2 to Table 5.1-4 in SCCH, and "SDCALL_REQ(User Data)" message have been transmitted from an Interoperability Tester, verify that SU No.2 receives User Data properly, and transmits a "SDCALL_RESP" message shown in Table 5.1-17 indicating "Receive Success" that include any of "INFO4" messages shown in Table 5.1-2 (the instructed Destination is SU No.1) to SCCH.
- (3) When the Interoperability Tester transmits a "TX_REL(Outbound)" message shown in Table 5.1-9 that includes "INFO4 (EOT)" message shown in Table 5.1-5, verify that the SU shifts its channel frequency to the channel frequency of the Home repeater.

5.1.5.2.2.2. Receive Success - (Unconfirmed)

- (1) SU No.2 shifts its frequency channel based on the procedure shown in Section 5.1.1.
- (2) When an Interoperability Tester transmits a SDCALL_REQ (Header) message shown in Table 5.1-16 that includes any of INFO4 message shown in Table 5.1-2 to Table 5.1-4 in SCCH, SDCALL_REQ(User Data) message, verify that SU No.2 receives User Data properly.
- (3) When an Interoperability Tester transmits a "TX_REL(Outbound)" message shown in Table 5.1-9 that includes "INFO4 (EOT)" message shown in Table 5.1-5, verify that the SU shifts its channel frequency to the channel frequency of the Home repeater.

5.1.5.2.2.3. Full Retry - (Confirmed)

- (1) SU No.2 shifts its frequency channel based on the procedure shown in Section 5.1.1.
- (2) When an Interoperability Tester has transmitted "SDCALL_REQ(Header)" message shown in Table 5.1-16 that includes any of "INFO4" messages shown in Table 5.1-2 to Table 5.1-4 in SCCH, and "SDCALL_REQ(User Data)" message that includes an invalid Message CRC from an Interoperability Tester, verify that the SU No.2 transmits a "SDCALL_RESP" message shown in Table 5.1-17 indicating re-transmission of all the messages that include INFO4 message shown in Table 5.1-2 (the instructed Destination is SU No.1) in SCCH.

5.1.6. Data Call Tests

This test shall verify that contents of messages used for Data Call are correct, that the unit under test correctly responds to these messages, and that the called unit outputs normal received data.

This test includes the test methods for the following two modes.

- (1) Broadcast Data Call
- (2) Unit to Unit Data Call

Figure 5.1-2 shows the configuration diagram for testing. In the event that an SU by itself cannot realize the Data Call functions, testing can be done by connecting peripheral equipment such as a PC to the SU.

The following 12 types of messages shall be applied.

- Table 5.1-1 : ISM INFO4 / INFO2 message
- Table 5.1-2 : OSM INFO4 / INFO2 (Busy Repeater Message) message
- Table 5.1-3 : OSM INFO4 / INFO2 (Free Repeater Message) message
- Table 5.1-4 : OSM INFO4 / INFO2 (Site ID Message Message) message
- Table 5.1-5 : ISM / OSM INFO4 (EOT) message
- Table 5.1-6 : CALL_REQ message from SU
- Table 5.1-7 : CALL_CONN_RESP message from Interoperability Tester
- Table 5.1-8 : CALL_RESP message from Interoperability Tester
- Table 5.1-9 : TX_REL(Inbound) message from SU
- Table 5.1-10 : TX_REL(Outbound) message from Interoperability Tester
- Table 5.1-18 : DCALL (Header) message
- Table 5.1-19 : DCALL_ACK message from Interoperability Tester

It is recommended that DCALL (User Data) messages are constructed using User Data having a data length that is divided into multiple packets. No contents of User Data are specified in this document.

5.1.6.1. Broadcast Data Call Test

In this test, parameters for messages to be used shall apply the values for Group Call.

5.1.6.1.1. Testing the Calling SU

5.1.6.1.1.1. Group Call Success

- (1) Link connection will be shown in Section 5.1.1.
- (2) When SU No.1 has started Data Call, verify that the SU transmits DCALL (Header) message shown in Table 5.1-18 that includes INFO4 message shown in Table 5.1-1 in SCCH, and DCALL(User Data) message.
- (3) (2)After transmitting abovementioned messages, verify that the SU transmits a "TX_REL(Inbound)" message shown in Table 5.1-9 that includes "INFO4 (EOT)" message shown in Table 5.1-5, and shifts its channel frequency to the channel frequency of the Home repeater.

5.1.6.1.2. Testing the Called SU

- (1) SU No.2 shifts its frequency channel based on the procedure shown in Section 5.1.1.
- (2) When a DCALL_REQ(Header) message shown in Table 5.1-18 that includes any of "INFO4" message shown in Table 5.1-2 to Table 5.1-4 in SCCH, DCALL_REQ(User Data) message, and "TX_REL(Outbound)" shown in Table 5.1-10 that includes "INFO4 (EOT)" message shown in Table 5.1-5, verify that SU No.2 receives User Data properly and shifts its channel frequency to the

channel frequency of the Home repeater.

5.1.6.2. Unit to Unit Data Call Test

In this test, parameters for messages to be used shall apply the values for Individual Call.

The procedure for a Unit to Unit Data Call is different between Confirmed format and Unconfirmed format.

To verify the interoperability, a unit under test shall pass the test item for at least either of the Confirmed format or the Unconfirmed format.

In the case of the Confirmed format, a unit under test shall pass the test items specified in Section 5.1.6.2.1.1 and Section 5.1.6.2.2.1.

In the case of the Unconfirmed format, a unit under test shall pass the test items specified in Section 5.1.6.2.1.2 and Section 5.1.6.2.2.2.

5.1.6.2.1. Testing the Calling SU

5.1.6.2.1.1. Individual Call Permission - (Confirmed)

- (1) Link connection will be shown in Section 5.1.1.
- (2) When SU No.1 has started Data Call, verify that the SU transmits a DCALL(Header) message shown in Table 5.1-18 that includes "INFO4" message shown in Table 5.1-1 in SCCH, and DCALL(User Data) message.
- (3) When a DCALL_ACK message shown in Table 5.1-19 indicating "Receive Success" that include any of "INFO4" messages shown in Table 5.1-2 to Table 5.1-4 (the instructed Destination is SU No.1) in SCCH has been transmitted from an Interoperability Tester, verify that SU No.1 transmits "TX_REL(Inbound)" shown in Table 5.1-9 that includes INFO4(EOT) message shown in Table 5.1-5, and shifts its channel frequency to the channel frequency of the Home repeater.

5.1.6.2.1.2. Individual Call Permission - (Unconfirmed)

- (1) Link connection will be shown in Section 5.1.1.
- (2) When SU No.1 has started Data Call, verify that the SU transmits DCALL(Header) message shown in Table 5.1-18 that includes INFO4 message shown in Table 5.1-1 in SCCH and DCALL(User Data) message.
- (3) (2)After transmitting abovementioned messages, verify that the SU transmits a "TX_REL(Inbound)" message shown in Table 5.1-9 that includes "INFO4(EOT)" message shown in Table 5.1-5, and shifts its channel frequency to the channel frequency of the Home repeater.

5.1.6.2.1.3. Full Retry - (Confirmed)

- (1) Perform step (1) and (2) in Section 5.1.6.2.1.1.
- (2) When a DCALL_ACK message shown in Table 5.1-19 indicating re-transmission of all the messages that include any of "INFO4" messages shown in Table 5.1-2 to Table 5.1-4 (the instructed Destination is SU No.1) in SCCH has been transmitted by using an Interoperability Tester, verify that the SU No.1 transmits a DCALL(Header) message shown in Table 5.1-16 that includes "INFO4" message shown in Table 5.1-1, and DCALL(User Data) message to SCCH.

5.1.6.2.2. Testing the Called SU

5.1.6.2.2.1. Incoming Call Success - (Confirmed)

- (1) SU No.2 shifts its frequency channel based on the procedure shown in Section 5.1.1.
- (2) When a DCALL(Header) message shown in Table 5.1-16 that includes any of INFO4 message shown in Table 5.1-2 to Table 5.1-4 in SCCH, and DCALL(User Data) message have been transmitted from an Interoperability Tester, verify that SU No.2 receives User Data properly, and transmits a DCALL_ACK message shown in Table 5.1-19 indicating "Receive Success" that include any of "INFO4" messages shown in Table 5.1-2 (the instructed Destination is SU No.1) to SCCH.
- (3) When the Interoperability Tester transmits a "TX_REL(Outbound)" message shown in Table 5.1-9 that includes "INFO4 (EOT)" message shown in Table 5.1-5, verify that the SU shifts its channel frequency to the channel frequency of the Home repeater.

5.1.6.2.2.2. Receive Success - (Unconfirmed)

- (1) SU No.2 shifts its frequency channel based on the procedure shown in Section 5.1.1.
- (2) When a DCALL(Header) message shown in Table 5.1-16 that include any of "INFO4" message shown in Table 5.1-2 to Table 5.1-4 in SCCH and a DCALL(User Data) message are transmitted from an Interoperability Tester, verify that SU No.2 receives User Data properly.
- (3) When an Interoperability Tester transmits a "TX_REL(Outbound)" message shown in Table 5.1-9 that includes "INFO4 (EOT)" message shown in Table 5.1-5, verify that the SU shifts its channel frequency to the channel frequency of the Home repeater.

5.1.6.2.2.3. Full Retry - (Confirmed)

- (1) SU No.2 shifts its frequency channel based on the procedure shown in Section 5.1.1.
- (2) When DCALL(Header) message shown in Table 5.1-18 that includes any of "INFO4" messages shown in Table 5.1-2 to Table 5.1-4 in SCCH, and DCALL(User Data) message that includes an invalid Message CRC are transmitted from an Interoperability Tester, verify that the SU No.2 transmits a DCALL_ACK message shown in Table 5.1-19 indicating re-transmission of all the messages that include INFO4 message shown in Table 5.1-2 (the instructed Destination is SU No.1) to SCCH.

Table 5.1-18 DCALL (Header) message

	Single Trunked System	Multi Trunked System
CC Option	00	10
Call Type	100b (Individual Call) 001b (Group Call)	
Source	Home Repeater Value of Home Repeater number	Source Prefix Prefix of SU No.1
	Unit ID of SU No.1	
Destination	Home Repeater Value of Home Repeater number	Destination Prefix Value of Destination Prefix
	Unit ID of SU No.2 (Individual Call) Group ID (Group Call)	
Cipher Type	00b	
Key ID	000000b	
Packet Information	Except for the following, depends on the format to be used for testing. Delivery Flag = 0 Unconfirmed (Group Call, Individual Call) Delivery Flag = 1 Confirmed (Individual Call)	

Table 5.1-19 DCALL_ACK message

	Single Trunked System	Multi Trunked System
CC Option	00	10
Call Type	100b	
Source	Home Repeater Value of Home Repeater number	Source Prefix Prefix of SU No.2
	Unit ID of SU No.2	
Destination	Home Repeater Value of Home Repeater number	Destination Prefix Prefix of SU No.1
	Unit ID of SU No.1	
Response Information	00 001b (Receive Success) 11 001b (Full Retry)	
Error Block Flag	Depends on the format to be used for testing.	

5.1.7. Status Call Tests

This test shall verify that contents of messages used for a Status Call are correct, and that the unit under test correctly responds to these messages.

This test includes the test methods for the following two modes.

- (1) Broadcast Status Call
- (2) Status Call

Figure 5.1-2 shows the configuration diagram for testing. In the event that an SU by itself cannot realize the Status Call functions, testing can be done by connecting peripheral equipment such as a PC to the SU.

The following 12 types of messages shall be applied.

- Table 5.1-1 : ISM INFO4 / INFO2 message
- Table 5.1-2 : OSM INFO4 / INFO2 (Busy Repeater Message) message
- Table 5.1-3 : OSM INFO4 / INFO2 (Free Repeater Message) message
- Table 5.1-4 : OSM INFO4 / INFO2 (Site ID Message Message) message
- Table 5.1-5 : ISM / OSM INFO4 (EOT) message
- Table 5.1-6 : CALL_REQ message from SU
- Table 5.1-7 : CALL_CONN_RESP message from Interoperability Tester
- Table 5.1-8 : CALL_RESP message from Interoperability Tester
- Table 5.1-9 : TX_REL(Inbound) message from SU
- Table 5.1-10 : TX_REL(Outbound) message from Interoperability Tester
- Table 5.1-20 : STAT_REQ message
- Table 5.1-21 : STAT_RESP message

5.1.7.1. Broadcast Status Call Test

In this test, parameters for messages to be used shall apply the values for Group Call.

5.1.7.1.1. Testing the Calling SU

5.1.7.1.1.1. Status Call Success

- (1) Link connection will be shown in Section 5.1.1.
- (2) When SU No.1 has started Status Call, verify that the SU transmits STAT_REQ message shown in Table 5.1-16 that includes INFO4 message shown in Table 5.1-1 in SCCH.
- (3) (2)After transmitting abovementioned messages, verify that the SU transmits a TX_REL (Inbound) message shown in Table 5.1-9 that includes INFO4 (EOT) message shown in Table 5.1-5, and shifts its channel frequency to the channel frequency of the Home repeater.

5.1.7.1.2. Testing the Called SU

- (1) SU No.2 shifts its frequency channel based on the procedure shown in Section 5.1.1.
- (2) When a STAT_REQ message shown in Table 5.1-16 that includes any of INFO4 message shown in Table 5.1-2 to Table 5.1-4 in SCCH is transmitted from an Interoperability Tester, verify that SU No.2 receives the status properly.
- (3) When the Interoperability Tester transmits a "TX_REL(Outbound)" message shown in Table 5.1-9 that includes "INFO4 (EOT)" message shown in Table 5.1-5, verify that the SU shifts its channel frequency to the channel frequency of the Home repeater.

5.1.7.2. Status Call Test

In this test, parameters for messages to be used shall apply the values for Individual Call. The procedure for Status Call is different between Confirmed format and Unconfirmed format. To verify the interoperability, a unit under test shall pass the test item for at least either of the Confirmed format or the Unconfirmed format.

In the case of the Confirmed format, a unit under test shall pass the test items specified in Section 5.1.7.2.1.1 and Section 5.1.7.2.2.1. In the case of the Unconfirmed format, a unit under test shall pass the test items specified in Section 5.1.7.2.1.2 and Section 5.1.7.2.2.2.

5.1.7.2.1. Testing the Calling SU

5.1.7.2.1.1. Status Call Success – (Confirmed)

- (1) Link connection will be shown in Section 5.1.1.
- (2) When SU No.1 has started Status Call, verify that the SU transmits STAT_REQ message shown in Table 5.1-16 that includes INFO4 message shown in Table 5.1-1 in SCCH.
- (3) When a STAT_RESP message shown in Table 5.1-21 indicating “Receive Success” that include any of “INFO4” messages shown in Table 5.1-2 to Table 5.1-4 (the instructed Destination is SU No.1) in SCCH has been transmitted from an Interoperability Tester, verify that SU No.1 transmits “TX_REL(Inbound)” shown in Table 5.1-9 that includes INFO4(EOT) message shown in Table 5.1-5, and shifts its channel frequency to the channel frequency of the Home repeater.

5.1.7.2.1.2. Status Call Success – (Unconfirmed)

- (1) Link connection will be shown in Section 5.1.1.
- (2) When SU No.1 has started Status Call, verify that the SU transmits STAT_REQ message shown in Table 5.1-16 that includes INFO4 message shown in Table 5.1-1 in SCCH.
- (3) After transmitting abovementioned messages at step (2), verify that the SU transmits a TX_REL (Inbound) message shown in Table 5.1-9 that includes INFO4 (EOT) message shown in Table 5.1-5, and shifts its channel frequency to the channel frequency of the Home repeater.

5.1.7.2.2. Testing the Called SU

5.1.7.2.2.1. Receive Success - (Confirmed)

- (1) SU No.2 shifts its frequency channel based on the procedure shown in Section 5.1.1.
- (2) When a STAT_REQ message shown in Table 5.1-16 that includes any of INFO4 message shown in Table 5.1-2 to Table 5.1-4 in SCCH have been transmitted from an Interoperability Tester, verify that SU No.2 receives the status properly, and transmits a STAT_RESP message shown in Table 5.1-21 indicating Receive Success that include any of “INFO4” messages shown in Table 5.1-2 (the instructed Destination is SU No.1) in SCCH.
- (3) When the Interoperability Tester transmits a “TX_REL(Outbound)” message shown in Table 5.1-9 that includes “INFO4 (EOT)” message shown in Table 5.1-5, verify that the SU shifts its channel frequency to the channel frequency of the Home repeater.

5.1.7.2.2.2. Receive Success - (Unconfirmed)

- (1) SU No.2 shifts its frequency channel based on the procedure shown in Section 5.1.1.
- (2) When a STAT_REQ message shown in Table 5.1-16 that includes any of "INFO4" message shown in Table 5.1-2 to Table 5.1-4 in SCCH is transmitted from an Interoperability Tester, verify that SU No.2 receives User Data properly.
- (3) When a TX_REL (Outbound) message shown in Table 5.1-9 that includes INFO4 (EOT) message shown in Table 5.1-5 has been transmitted from an Interoperability Tester, verify that the SU shifts its channel frequency to the channel frequency of the Home repeater.

Table 5.1-20 STAT_REQ message

	Single Trunked System	Multi Trunked System
CC Option	00 (Individual Call, Group Call) 80 (Emergency Call)	10 (Individual Call, Group Call) 90 (Emergency Call)
Call Type	100b (Individual Call) 001b (Group Call)	
Status Call Option	00000b (Unconfirmed) 01000b (Confirmed)	
Source	Home Repeater Value of Home Repeater number	Source Prefix Prefix of SU No.1
	Unit ID of SU No.1	
Destination	Home Repeater Value of Home Repeater number	Destination Prefix Value of Destination Prefix
	Unit ID of SU No.2 (Individual Call) Group ID (Group Call)	
Status	01~CF (User definable) D0 (Paging) E0 (Emergency)	

Table 5.1-21 STAT_RESP message

	Single Trunked System	Multi Trunked System
CC Option	00	10
Call Type	100b (Individual Call) 001b (Group Call)	
Source	Home Repeater Value of Home Repeater number	Source Prefix Prefix of SU No.2
	Unit ID of SU No.2	
Destination	Home Repeater Value of Home Repeater number	Destination Prefix Prefix of SU No.1
	Unit ID of SU No.1	
Cause(SS)	01 (Receive Success)	

5.1.8. Status Inquiry Tests

This test shall verify that contents of messages used for Status Inquiry processing are correct, and that the unit under test correctly responds to these messages.

Figure 5.1-2 shows the configuration diagram for testing. In the event that an SU by itself cannot realize the Status Inquiry functions, testing can be done by connecting peripheral equipment such as a PC to the SU.

The following 12 types of messages shall be applied.

- Table 5.1-1 : ISM INFO4 / INFO2 message
- Table 5.1-2 : OSM INFO4 / INFO2 (Busy Repeater Message) message
- Table 5.1-3 : OSM INFO4 / INFO2 (Free Repeater Message) message
- Table 5.1-4 : OSM INFO4 / INFO2 (Site ID Message Message) message
- Table 5.1-5 : ISM / OSM INFO4 (EOT) message
- Table 5.1-6 : CALL_REQ message from SU
- Table 5.1-7 : CALL_CONN_RESP message from Interoperability Tester
- Table 5.1-8 : CALL_RESP message from Interoperability Tester
- Table 5.1-9 : TX_REL(Inbound) message from SU
- Table 5.1-10 : TX_REL(Outbound) message from Interoperability Tester
- Table 5.1-22 : STAT_INQ_REQ message
- Table 5.1-23 : STAT_INQ_RESP message

5.1.8.1. Testing the Calling SU

5.1.8.1.1. Status Inquiry Success

- (1) Link connection will be shown in Section 5.1.1.
- (2) When SU No.1 has started Status Inquiry, verify that the SU transmits STAT_INQ_REQ message shown in Table 5.1-16 that includes INFO4 message shown in Table 5.1-1 in SCCH.
- (3) When a STAT_INQ_RESP message shown in Table 5.1-23 indicating Receive Success that include any of "INFO4" messages shown in Table 5.1-2 to Table 5.1-4 (the instructed Destination is SU No.1) in SCCH has been transmitted from an Interoperability Tester, verify that SU No.1 receives the status properly, and transmits TX_REL(Inbound) shown in Table 5.1-9 that includes INFO4(EOT) message shown in Table 5.1-5, and shifts its channel frequency to the channel frequency of the Home repeater.

5.1.8.2. Testing the Called SU

5.1.8.2.1. Receive Success

- (1) SU No.2 shifts its frequency channel based on the procedure shown in Section 5.1.1.
- (2) When a STAT_INQ_REQ message shown in Table 5.1-16 that includes any of INFO4 message shown in Table 5.1-2 to Table 5.1-4 in SCCH have been transmitted from an Interoperability Tester, verify that SU No.2 transmits a STAT_INQ_RESP message shown in Table 5.1-23 indicating Receive Success that include any of "INFO4" messages shown in Table 5.1-2 (the instructed Destination is SU No.1) in SCCH.
- (3) When a TX_REL (Outbound) message shown in Table 5.1-9 that includes INFO4(EOT) message shown in Table 5.1-5 has been transmitted from an Interoperability Tester, verify that the SU shifts its channel frequency to the channel frequency of the Home repeater.

Table 5.1-22 STAT_INQ_REQ message

	Single Trunked System	Multi Trunked System
CC Option	00	10
Call Type	100b	
Status Call Option	01000b (Confirmed)	
Source	Home Repeater Value of Home Repeater number Unit ID of SU No.1	Source Prefix Prefix of SU No.1
Destination	Home Repeater Value of Home Repeater number Unit ID of SU No.2	Destination Prefix Prefix of SU No.2

Table 5.1-23 STAT_INQ_RESP message

	Single Trunked System	Multi Trunked System
CC Option	00	10
Call Type	100b	
Source	Home Repeater Value of Home Repeater number Unit ID of SU No.2	Source Prefix Prefix of SU No.2
Destination	Home Repeater Value of Home Repeater number Unit ID of SU No.1	Destination Prefix Prefix of SU No.1
Cause(SS)	01 (Receive Success)	
Status	01~CF (User definable)	

5.1.9. Remote Control Tests

This test shall verify that contents of messages used for the Remote Control functions are correct, and that the unit under test correctly responds to these messages.

Figure 5.1-2 shows the configuration diagram for testing. In the event that an SU by itself cannot realize the Remote Control functions, testing can be done by connecting peripheral equipment such as a PC to the SU.

The following 12 types of messages shall be applied.

- Table 5.1-1 : ISM INFO4 / INFO2 message
- Table 5.1-2 : OSM INFO4 / INFO2 (Busy Repeater Message) message
- Table 5.1-3 : OSM INFO4 / INFO2 (Free Repeater Message) message
- Table 5.1-4 : OSM INFO4 / INFO2 (Site ID Message Message) message
- Table 5.1-5 : ISM / OSM INFO4 (EOT) message
- Table 5.1-6 : CALL_REQ message from SU
- Table 5.1-7 : CALL_CONN_RESP from Interoperability Tester
- Table 5.1-8 : CALL_RESP message from Interoperability Tester
- Table 5.1-9 : TX_REL(Inbound) message from SU
- Table 5.1-10 : TX_REL(Outbound) message from Interoperability Tester
- Table 5.1-24 : REM_CON_REQ message
- Table 5.1-25 : REM_CON_RESP message

5.1.9.1. Testing the Calling SU

5.1.9.1.1. Remote Control Success

- (1) Link connection will be shown in Section 5.1.1.
- (2) When SU No.1 has started Remote Control, verify that the SU transmits REM_CON_REQ message shown in Table 5.1-16 that includes INFO4 message shown in Table 5.1-1 in SCCH.
- (3) When a REM_CON_RESP message shown in Table 5.1-25 indicating Receive Success that include any of "INFO4" messages shown in Table 5.1-2 to Table 5.1-4 (the instructed Destination is SU No.1) in SCCH has been transmitted from an Interoperability Tester, verify that SU No. 1 becomes the idle state.

5.1.9.2. Testing the Called SU

5.1.9.2.1. Receive Success

- (1) SU No.2 shifts its frequency channel based on the procedure shown in Section 5.1.1.
- (2) When a REM_CON_REQ message shown in Table 5.1-16 that includes any of INFO4 message shown in Table 5.1-2 to Table 5.1-4 in SCCH have been transmitted from an Interoperability Tester, verify that SU No.2 transmits a REM_CON_RESP message shown in Table 5.1-25 indicating Receive Success that include any of "INFO4" messages shown in Table 5.1-2 (the instructed Destination is SU No.1) in SCCH.
- (3) Verify that SU No. 2 behaves in accordance with the contents of the Control Command information elements and Control Parameter information elements.

Table 5.1-24 REM_CON_REQ message

	Single Trunked System	Multi Trunked System
CC Option	00	10
G/U	1b (UNIT ID)	
Delivery	1b (Confirmed)	
Control Command	Depending on the test configuration	
Source	Home Repeater Value of Home Repeater number	Source Prefix Prefix of SU No.1
	Unit ID of SU No.1	
Destination	Home Repeater Value of Home Repeater number	Destination Prefix Prefix of SU No.2
	Unit ID of SU No.2	
Control Parameter	Depending on the test configuration	

Table 5.1-25 REM_CON_RESP message

	Single Trunked System	Multi Trunked System
CC Option	00	10
G/U	1b (UNIT ID)	
Control Command	Depending on the test configuration	
Source	Home Repeater Value of Home Repeater number	Source Prefix Prefix of SU No.2
	Unit ID of SU No.2	
Destination	Home Repeater Value of Home Repeater number	Destination Prefix Prefix of SU No.1
	Unit ID of SU No.1	
Cause(SS)	01 (Receive Success)	

5.1.10. Paging Tests

This test shall verify that contents of messages used for the Paging behaviors are correct, and that the unit under test correctly responds to these messages.

Figure 5.1-1 shows the configuration diagram for testing.

5.1.10.1. Testing the Calling SU

5.1.10.1.1. Paging Success

Testing Procedures shall be identical to those tests for Status Call as described in Section 5.1.7.2.1.1. The value representing Paging in the Status element is used for testing.

5.1.10.2. Testing the Called SU

5.1.10.2.1. Receive Success

Testing Procedures shall be identical to those tests for Status Call as described in Section 5.1.7.2.2.1. Verify that an SU performs the behavior specified by the respective manufacturer, such as an alert tone or an indicator, upon receipt of a status value representing "Paging".

5.1.11. Emergency Tests

This test shall verify that contents of messages used during the Emergency state are correct, that the unit under test correctly responds to these messages.

This test includes the test methods for the following two Emergency states.

- (1) Emergency Call
- (2) Emergency Alert

Figure 5.1-1 shows the configuration diagram for testing.

5.1.11.1. Emergency Call

In this test, we evaluate the validity of the description of a message used in the case in which an emergency Voice Call shall be performed, and verify whether or not the SU operates as intended in response to those messages.

This test includes the following 2 varieties of tests to evaluate the mode of operation.

- (1) Group Voice Call
- (2) Individual Voice Call

The test method of (1) and (2) are the same as shown in Section 5.1.2 and Section 5.1.3, respectively. Provided however that be sure to apply 80(Single Trunked) or 90(Multi Trunked) as a value of CC Option for each message.

Verify that the procedural steps for Emergency operation when a called SU has received vocal communication data in an Emergency status follows the steps stipulated by each manufacturer.

5.1.11.2. Emergency Alert

This test shall verify that contents of messages used for broadcasting the Emergency status are correct, and that the unit under test correctly responds to these messages.

This test includes the test methods for the following two modes.

- (1) Broadcast Status Call
- (2) Status Call

Testing procedure for mode (1) shall be identical to those specified in Section 5.1.7.1 and testing procedure for mode (2) shall be identical to those specified in Section 5.1.7.2.

A status value representing Emergency is used for testing. Verify that a called SU performs the behavior specified by the respective manufacturer, such as an alert tone or an indicator, upon receipt of a status value representing "Emergency".

5.1.12. Late Entry Test

This test shall verify that SU normally receives a call even if the SU participates in a voice call midway through the call.

Figure 5.1-1 shows the configuration diagram for testing.

This test shall be done with the following mode.

- (1) Conference Group Call

This testing shall be done only with the called SU. Testing shall be done using the SU No. 2 as the called SU.

5.1.12.1. Conference Group Call

In this test, parameters for messages to be used shall apply the values for Conference Group Call.

5.1.12.1.1. Testing the Called SU

- (1) Turn the SU No. 2 off.
- (2) Output voice call transmission signal from interoperability tester.
- (3) After turn on the power of SU No.2, verify that appropriate voice output from SU No.2

5.1.13. Priority Monitor Test

This test shall verify that an SU stops receiving a normal Group Call and an SU starts to receive a Group Call with the Priority Group ID, when the Group Call with the Priority Group ID takes place on another RTCH2 while the SU is in a receiving state on an RTCH2.

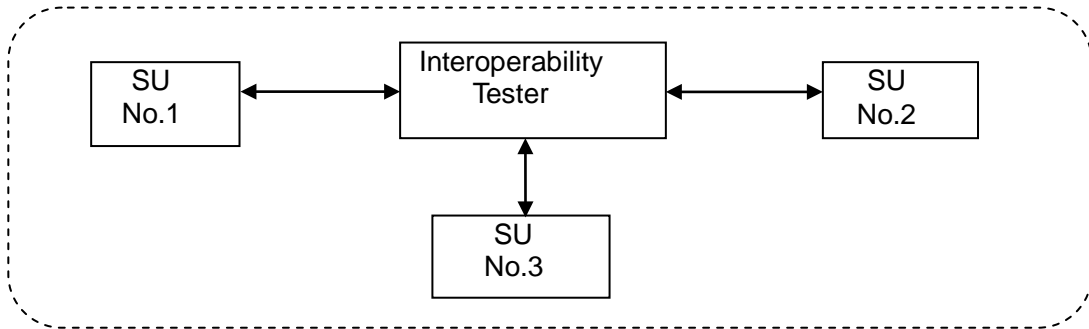

Figure 5.1-3 Priority Monitor Test

Figure 5.1-3 shows the configuration diagram for testing.

This test represents a case that SU No. 3 initiates a Conference Group Call using a Priority Group ID while making a Conference Group Call between the calling SU No. 1 and the called SU No. 2.

For explanation purposes, SU No. 1 is considered to transmit audio signals on an RTCH2-1 and SU No. 3 is considered to transmit audio signals on an RTCH2-2.

- (1) Keep SU No. 2 in the receive state on an RTCH2-1 in accordance with the Conference Group Call procedure specified in Section 5.1.2.
- (2) Start a Conference Group Call by SU No. 3 using a Priority Group ID and keep SU No. 3 in the transmit state on an RTCH2-2.
- (3) Verify that SU No. 2 migrates to the specified RTCH-2 and receives a Group Voice Call using a Priority Group ID.
- (4) Verify that SU No. 2 reverts to an RTCH2-1 upon completion of Group Voice Call on an RTCH2-2 using a Priority Group ID.

5.1.14. Transmission Trunking Test

This test shall verify the SU behaviors while in Transmission Trunking Mode. Trunking Mode in an SU and interoperability tester shall be configured as Transmission Trunking Mode. A configuration method for Trunking Mode shall be appropriately determined by the respective manufacturer.

Figure 5.1-1 shows the configuration diagram for testing. This test is done using Conference Group Voice Call or Individual Voice Call.

Transmission Trunking means an RTCH2 assignment process takes place each time when an SU transmits.

Trunking Mode is affected by the specifications of the manufacturer which manufactures an SU; hence, it is necessary to perform at least one of the following test items.

- (1) Verify that an SU begins to send a CALL_REQ message on an RTCH2 when the PTT control of SU is activated again after the SU ends transmission on an RTCH, under the condition that no Hold Time is configured for an interoperability tester.
- (2) Or, it may be verified that an SU conforms to Transmission Trunking behavior specified by the SU manufacturer.

5.1.15. Message Trunking Test

This test shall verify the SU behaviors while in Message Trunking Mode.

S Trunking Mode in an SU and interoperability tester shall be configured as Message Trunking Mode. A configuration method for Trunking Mode shall be appropriately determined by the respective manufacturer.

Figure 5.1-1 shows the configuration diagram for testing. This test is done using Individual Voice Call. This test is done using Individual Voice Call.

Message Trunking means a behavior that an SU can repeatedly transmit on the same RTCH2 during a period of Hold Time.

Trunking Mode is affected by the specifications of the manufacturer which manufactures an SU; hence, it is necessary to perform at least one of the following test items.

- (1) Verify that an SU retransmits on an RTCH2 when the PTT control of SU is activated again after the SU ends transmission on the RTCH2, under the condition that Hold Time is configured for an interoperability tester and that a TX_REL message is sent during the period of Hold Time.
- (2) Or, it may be verified that an SU conforms to Message Trunking behavior specified by the SU manufacturer.

5.1.16. Encryption Tests

This test shall verify that the calling SU performs the correct encryption processing and the called SU performs the correct decryption processing.

No mode to be used for testing shall be specified.

5.1.16.1. Encrypted Voice Call Tests

Figure 5.1-1 shows the configuration diagram for testing. Following is the message to be applied.

Table 5.1-26 : VCALL message (Encryption)

5.1.16.1.1. Encrypted Voice Call Test for Receiver

This test shall verify that when an interoperability tester sends an encrypted voice call, a unit under test correctly outputs the received audio signal.

Configuring conditions for Cipher Type and Key ID on the transmission side (interoperability tester) and the reception side (unit under test) as well as the received voice output conditions for respective configuring conditions are presented in Table 5.1-27

In the event that a Key ID for an interoperability tester is identical to that for a unit under test, the encryption key shall also be identical.

In this test, SCCH(INFO1) in the superframe included voice call data transmitted from the Interoperability tester is shown in Table 5.1-14, but apply Cipher Type and Key ID appropriately which match each parameter to be used in the encryption data.

- (1) Verify when an interoperability tester sends an encrypted voice call using a VCALL message and SCCH(INFO1) message as described in Table 5.1-26 and Table 5.1-14, SU No. 2 correctly outputs the received audio signal.
- (2) Verify that SU No. 2 behaves in accordance with the received audio signal output conditions as described in Table 5.1-27.

5.1.16.1.2. Encrypted Voice Call Test for Transmitter

This test shall verify that a unit under test correctly performs the encryption processing by verifying the received audio signals outputted from an interoperability tester when a unit under test sends an encrypted voice call.

- (1) Send an encrypted voice call using a VCALL message as described in Table 5.1-26 from SU No. 1. In addition, SCCH(INFO1) in the superframe included voice call data is shown in Table 5.1-12, but apply Cipher Type and Key ID appropriately which match each parameter to be used in the encryption data.
- (2) Compare the contents of the VCALL message and SCCH(INFO1) message received by an interoperability tester with those of the VCALL message and SCCH(INFO1) message as presented in Table 5.1-26 and Table 5.1-12.
- (3) Also, verify that an interoperability tester outputs the normal received audio signal.

5.1.16.2. Encrypted Short Data Call Tests

Figure 5.1-2 shows the configuration diagram for testing. Following is the message to be applied.

Table 5.1-28 : SDCALL_REQ(Header) message (Encryption)

5.1.16.2.1. Encrypted Short Data Call Test for Receiver

This test shall verify that when an interoperability tester sends an encrypted short data call, a unit under test correctly receives the user data.

Configuring conditions for Cipher Type and Key ID on the transmission side (interoperability tester) and the reception side (unit under test) as well as the data reception conditions for respective configuring conditions are presented in Table 5.1-29.

In the event that a Key ID for an interoperability tester is identical to that for a unit under

test, the encryption key shall also be identical.

- (1) Verify that SU No. 2 correctly receives User Data when an interoperability tester sends an encrypted short data call using a SDCALL_REQ (Header) message as described in Table 5.1-28 and a SDCALL_REQ (User Data) message.
- (2) Verify that SU No. 2 behaves in accordance with the data reception conditions as described in Table 5.1-29.

5.1.16.2.2. Encrypted Short Data Call Test for Transmitter

This test shall verify that the unit under test correctly performs the encryption processing by verifying the received data outputted from an interoperability tester when a unit under test sends an encrypted short data call.

- (1) Send an encrypted short data call using a SDCALL_REQ (Header) message as described in Table 5.1-28 and a SDCALL_REQ (User Data) message from SU No. 1.
- (2) Compare the contents of the SDCALL_REQ message received by an interoperability tester with those of the SDCALL_REQ message as presented in Table 5.1-28.
- (3) Also, verify that an interoperability tester outputs the normal User Data.

5.1.16.3. Encrypted Data Call Tests

Figure 5.1-2 shows the configuration diagram for testing. Following is the message to be applied.

Table 5.1-30 : DCALL(Header) message (Encryption)

5.1.16.3.1. Encrypted Data Call Test for Receiver

This test shall verify that when an interoperability tester sends an encrypted long data call, a unit under test correctly receives the user data.

Configuring conditions for Cipher Type and Key ID on the transmission side (interoperability tester) and the reception side (unit under test) as well as the data reception conditions for respective configuring conditions are presented in Table 5.1-29. In the event that a Key ID for an interoperability tester is identical to that for a unit under test, the encryption key shall also be identical.

- (1) Verify that SU No. 2 correctly receives User Data when an interoperability tester sends an encrypted long data call using a DCALL (Header) message as described in Table 5.1-30 and a DCALL (User Data) message.
- (2) Verify that SU No. 2 behaves in accordance with the data reception conditions as described in Table 5.1-29.

5.1.16.3.2. Encrypted Data Call Test for Transmitter

This test shall verify that a unit under test correctly performs the encryption processing by verifying the received data outputted from an interoperability tester when the unit under test sends an encrypted data call.

- (1) Send an encrypted long data call using a DCALL (Header) message as described in Table 5.1-30 and a DCALL (User Data) from SU No. 1.
- (2) Compare the contents of the DCALL message received by an interoperability tester with those of the DCALL message as described in Table 5.1-30.
- (3) Also, verify that an interoperability tester outputs the normal User Data.

Table 5.1-26 VCALL message (Encryption)

	Single Trunked System	Multi Trunked System
CC Option	00	10
Call Type	100b (Individual Call) 001b (Conference Group Call) 000b (Broadcast Call)	
Source	Home Repeater Value of Home Repeater number	Source Prefix Prefix of SU No.1
	Unit ID of SU No.1	
Destination	Home Repeater Value of Home Repeater number	Destination Prefix Value of Destination Prefix
	Group ID (Group Call) Unit ID of SU No.2 (Individual Call)	
Cipher Type	01b	
Key ID	000001b~111111b	

Table 5.1-27 Encryption Tests Condition for Voice Call

Cipher Type	Key ID	Receive Audio Output
Equal	Equal	Normal Audio
Equal	Not Equal	Mute or Abnormal Audio

Table 5.1-28 SDCALL_REQ(Header) message (Encryption)

T-Type	Single Trunked System	Multi Trunked System
CC Option	00	10
Call Type	100b (Individual Call) 001b (Group Call)	
Source	Home Repeater Value of Home Repeater number	Source Prefix Prefix of SU No.1
	Unit ID of SU No.1	
Destination	Home Repeater Value of Home Repeater number	Destination Prefix Value of Destination Prefix
	Unit ID of SU No.2 (Individual Call) Group ID (Group Call)	
Cipher Type	01b	
Key ID	000001b~111111b	
Packet Information	Except for the following, depends on the format to be used for testing. Delivery Flag = 0 (Group Call, Individual Call) Unconfirmed Delivery Flag = 1 (Individual Call) Confirmed	

Table 5.1-29 Encryption Tests Condition for Short Data Call / Data Call

Cipher Type	Key ID	Receive Audio Output
Equal	Equal	Normal Audio
Equal	Not Equal	Message CRC Error

Table 5.1-30 DCALL(Header) message (Encryption)

	Single Trunked System	Multi Trunked System
CC Option	00	10
Call Type	100b (Individual Call) 001b (Group Call)	
Source	Home Repeater Value of Home Repeater number	Source Prefix Prefix of SU No.1
	Unit ID of SU No.1	
Destination	Home Repeater Value of Home Repeater number	Destination Prefix Value of Destination Prefix
	Unit ID of SU No.2 (Individual Call) Group ID (Group Call)	
Cipher Type	01b	
Key ID	000001b~111111b	
Packet Information	Except for the following, depends on the format to be used for testing. Delivery Flag = 0 Unconfirmed (Group Call, Individual Call) Delivery Flag = 1 Confirmed (Individual Call)	

5.1.17. Registration Test

This test shall verify that contents of messages used for the Registration process are correct, and that the unit under test correctly responds to these messages. (Multi Trunked System only)

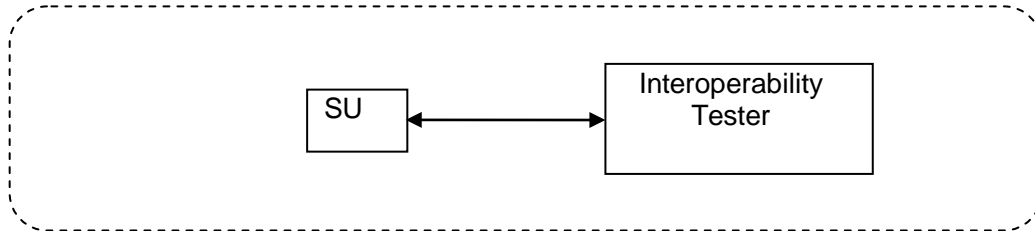

Figure 5.1-4 Set up for SU Test

Figure 5.1-4 shows the configuration diagram for testing. The following 10 types of messages shall be applied.

- Table 5.1-31 : ISM INFO4 message
- Table 5.1-32 : OSM INFO4 (Busy Repeater Message) message
- Table 5.1-33 : OSM INFO4 (Free Repeater Message) message
- Table 5.1-34 : OSM INFO4 / INFO2 (Site ID Message Message) message
- Table 5.1-35 : ISM / OSM INFO4 (EOT) message
- Table 5.1-36 : CALL_REQ message from SU
- Table 5.1-37 : CALL_RESP message from Interoperability Tester
- Table 5.1-38 : REG_REQ message from SU
- Table 5.1-39 : REG_RESP message from Interoperability Tester
- Table 5.1-40 : TX_REL(Inbound) message from SU

5.1.17.1. Registration Accept

- (1) Turn the power of SU ON.
- (2) Verify that the SU transmits a "CALL_REQ" message shown in Table 5.1-6 that includes a "INFO4" message shown in Table 5.1-31 in SCCH.
- (3) When a "CALL_RESP" message shown in Table 5.1-8 which includes any of "INFO4" messages shown in Table 5.1-32 to Table 5.1-34 in SCCH is transmitted from Interoperability Tester, verify that the SU sends "REG_REQ" message shown in Table 5.1-38 which includes "INFO4" message shown in Table 5.1-31 in SCCH.
- (4) When a "REG_RESP" message indicating "Accept" shown in Table 5.1-39 which includes any of "INFO4" messages shown in Table 5.1-32 to Table 5.1-34 in SCCH is transmitted from Interoperability Tester, verify that the SU sends "TX_REL(Inbound)" message shown in Table 5.1-38 which includes "INFO4(EOT)" message shown in Table 5.1-35, and then shifts its channel frequency to the channel frequency of the Home repeater.

5.1.17.2. Registration Fail

- (1) Turn the power of SU ON.
- (2) Verify that the SU transmits a "CALL_REQ" message shown in Table 5.1-6 that includes a "INFO4" message shown in Table 5.1-31 in SCCH.
- (3) When a "CALL_RESP" message shown in Table 5.1-37 which includes any of "INFO4" messages shown in Table 5.1-32 to Table 5.1-34 in SCCH is transmitted from Interoperability Tester, verify that the SU sends "REG_REQ" message shown in Table 5.1-38 which includes "INFO4" message shown in Table 5.1-31 in SCCH.
- (4) When a "REG_RESP" message indicating "Fail" shown in Table 5.1-8 which includes any of "INFO4" messages shown in Table 5.1-32 to Table 5.1-34 in SCCH is transmitted from Interoperability Tester, verify that the SU sends "TX_REL(Inbound)" message shown in Table 5.1-38 which includes "INFO4(EOT)" message shown in Table 5.1-35, and then becomes idle mode or "Collect Repeater" acquisition mode.

5.1.17.3. Registration Refuse

- (1) Turn the power of SU ON.
- (2) Verify that the SU transmits a "CALL_REQ" message shown in Table 5.1-6 that includes a "INFO4" message shown in Table 5.1-31 in SCCH.
- (3) When a "CALL_RESP" message shown in Table 5.1-37 which includes any of "INFO4" messages shown in Table 5.1-32 to Table 5.1-34 in SCCH is transmitted from Interoperability Tester, verify that the SU sends "REG_REQ" message shown in Table 5.1-38 which includes "INFO4" message shown in Table 5.1-31 in SCCH.
- (4) When a "REG_RESP" message indicating "Refuse" shown in Table 5.1-39 which includes any of "INFO4" messages shown in Table 5.1-32 to Table 5.1-34 in SCCH is transmitted from Interoperability Tester, verify that the SU sends "TX_REL(Inbound)" message shown in Table 5.1-38 which includes "INFO4(EOT)" message shown in Table 5.1-35, updates information on a Site in which an access permission request has been rejected, and then become "Collect Repeater" acquisition mode.

Table 5.1-31 ISM INFO4 message

Structure	00b
Area	Value of Area
Repeater in Use	Value of Collect Repeater number
Destination Prefix	00000b
Destination Unit ID	7FB
G/U	0b

Table 5.1-32 OSM INFO4 (Busy Repeater Message) message

Structure	00b
Area	Value of Area
Go to Repeater	Value of Collect Repeater number
Destination Prefix	00000b
Destination Unit ID	7FB
G/U	0b

Table 5.1-33 OSM INFO4 (Free Repeater Message) message

Structure	00b
Area	Value of Area
Free Repeater1	Value of Free Repeater number
Free Repeater1	Value of Free Repeater number
ID	7FC

Table 5.1-34 OSM INFO4 / INFO2 (Site ID Message) message

Structure	00b (INFO4)
Area	Value of Area
Site Type	Value of Site Type
Site Code	Value of Site Code
ID	7F9

Table 5.1-35 ISM / OSM INFO4 (EOT) message

Structure	00b (INFO4)
Area	Value of Area
Repeater in Use / Go to Repeater	11111b
Destination Prefix	Value of Destination Prefix
Destination ID	7FB
G/U	0b

Table 5.1-36 CALL_REQ message

CC Option	10
Call Type	011b (Session Call)
Source Prefix	Value of Source Prefix
Source Unit ID	Unit ID of SU
Destination Prefix	00000b
Destination Unit ID	7FB
System ID Option	10000b / 01000b
System ID	Value of System ID

Table 5.1-37 CALL_RESP message

CC Option	10
Call Type	011b (Session Call)
Free Repeater	Any value in the range of 00001b-11110b
Source Prefix	Value of Source Prefix
Source Unit ID	Unit ID of SU
Destination Prefix	00000b
Destination Unit ID	7FB
System ID Option	10000b / 01000b
System ID	Value of System ID

Table 5.1-38 REG_REQ message

Registration Option	00000b
(Subscriber Home) System ID	Any System ID
Source Prefix	Prefix Number of SU
Source Unit ID	Unit ID of SU
Group Prefix	Selected Group Prefix Number
Group ID	Selected Group ID of SU
Subscriber Type	0000
Version Number	Any
Registration Sequence Number	Any

Table 5.1-39 REG_RESP message

Registration Option	00000b
(Subscriber Home) System ID	any System ID
Destination Prefix	Prefix Number of SU
Destination Unit ID	Unit ID of SU
Group Prefix	Selected Group Prefix Number
Group ID	Selected Group ID of SU
Cause(MM)	01(Accept) / 06(Fail) / 08(Refuse)
Home Repeater	Value of Home Repeater number
2nd Home Repeater	Value of 2nd Home Repeater number
Visitor Unit ID	Any
Visitor Group ID	Any

Table 5.1-40 TX_REL (Inbound) message

CC Option	10
Call Type	011b (Session Call)
Source Prefix	Value of Source Prefix
Source Unit ID	Unit ID of SU
Destination Prefix	00000b
Destination Unit ID	7FB

5.1.18. Registration Command Test

In this test, we evaluate the validity of the description of message used in the case in which TC instructs a SU to execute registration process, and verify whether or not the SU operates as intended in response to those messages. (Multi Trunked System only)
The connection configuration of this test is shown in Figure 5.1-4. The following only one kind of message will be used.

Table 5.1-41 : To set OSM INFO4 (REG_COM) message

- (1) Be sure to make SU an idle mode in which Registration process has been completed.
- (2) When SU transmits "REG_COM" message shown in Table 5.1-41 from an Interoperability Tester, verify that the SU starts Registration process shown in Section 5.1.17.

Table 5.1-41 OSM INFO4 (REG_COM) message

Structure	00b
Area	Value of Area
Go to Repeater	0
Destination Prefix	Prefix Number of SU
Destination Unit ID	Unit ID of SU
G/U	1b

5.1.19. Registration Clear Test

This test shall verify that contents of messages used for clearing the Registration information are correct, and that the unit under test correctly responds to these messages. (Multi Trunked System only)

This test shall be done when the SU is turned OFF.

Figure 5.1-4 shows the configuration diagram for testing. The following 10 types of messages shall be applied.

Table 5.1-31 : ISM INFO4 message

Table 5.1-32 : OSM INFO4 (Busy Repeater Message) message

Table 5.1-33 : OSM INFO4 (Free Repeater Message) message

Table 5.1-34 : OSM INFO4 / INFO2 (Site ID Message Message) message

Table 5.1-35 : ISM / OSM INFO4 (EOT) message

Table 5.1-36 : SU の CALL_REQ message

Table 5.1-37 : CALL_RESP message from Interoperability Tester

Table 5.1-40 : TX_REL(Inbound) message from SU

Table 5.1-42 : REG_C_REQ message from SU

Table 5.1-43 : REG_C_RESP message from Interoperability Tester

5.1.19.1. Registration Clear Accept

- (1) Keep an SU in the idle state after the Registration process.
- (2) When the power of SU has been turned OFF, verify that the SU transmits a "CALL_REQ" message shown in Table 5.1-6 that includes a "INFO4" message shown in Table 5.1-31.
- (3) When a "CALL_RESP" message shown in Table 5.1-37 which includes any of "INFO4" messages shown in Table 5.1-32 to Table 5.1-34 in SCCH is transmitted from Interoperability Tester, verify that the SU sends "REG_C_REQ" message shown in Table 5.1-38 which includes "INFO4" message shown in Table 5.1-31 in SCCH.
- (4) When a "REG_C_RESP" message indicating "Accept" shown in Table 5.1-43 which includes any of "INFO4" messages shown in Table 5.1-32 to Table 5.1-34 in SCCH is transmitted from Interoperability Tester, verify that the SU sends "TX_REL(Inbound)" message shown in Table 5.1-38 which includes "INFO4(EOT)" message shown in Table 5.1-35.

5.1.19.2. Registration Clear Fail

- (1) Keep an SU in the idle state after the Registration process.
- (2) When the power of SU has been turned OFF, verify that the SU transmits a "CALL_REQ" message shown in Table 5.1-6 that includes a "INFO4" message shown in Table 5.1-31.
- (3) When a "CALL_RESP" message shown in Table 5.1-37 which includes any of "INFO4" messages shown in Table 5.1-32 to Table 5.1-34 in SCCH is transmitted from Interoperability Tester, verify that the SU sends "REG_C_REQ" message shown in Table 5.1-38 which includes "INFO4" message shown in Table 5.1-31 in SCCH.
- (4) When a "REG_C_RESP" message indicating "Fail" shown in Table 5.1-43 which includes any of "INFO4" messages shown in Table 5.1-32 to Table 5.1-34 in SCCH is transmitted from Interoperability Tester, verify that the SU sends "TX_REL(Inbound)" message shown in Table 5.1-38 which includes "INFO4(EOT)" message shown in Table 5.1-35.

5.1.19.3. Registration Clear Refuse

- (1) Keep an SU in the idle state after the Registration process.
- (2) When the power of SU has been turned OFF, verify that the SU transmits a "CALL_REQ" message shown in Table 5.1-6 that includes a "INFO4" message shown in Table 5.1-31.
- (3) When a "CALL_RESP" message shown in Table 5.1-37 which includes any of "INFO4" messages shown in Table 5.1-32 to Table 5.1-34 in SCCH is transmitted from Interoperability Tester, verify that the SU sends "REG_C_REQ" message shown in Table 5.1-38 which includes "INFO4" message shown in Table 5.1-31 in SCCH.
- (4) When a "REG_C_RESP" message indicating "Refuse" shown in Table 5.1-43 which includes any of "INFO4" messages shown in Table 5.1-32 to Table 5.1-34 in SCCH is transmitted from Interoperability Tester, verify that the SU sends "TX_REL(Inbound)" message shown in Table 5.1-38 which includes "INFO4(EOT)" message shown in Table 5.1-35.

Table 5.1-42 REG_C_REQ message

Registration Option	00000b
(Subscriber Home) System ID	Any selected System ID
Source Prefix	Prefix Number of SU
Source Unit ID	Unit ID of SU

Table 5.1-43 REG_C_RESP message

Registration Option	00000b
(Subscriber Home) System ID	Any selected System ID
Destination Prefix	Prefix Number of SU
Destination Unit ID	Unit ID of SU
Cause(MM)	01(Accept) / 06(Fail) / 08(Refuse)

5.1.20. Group Registration Test

This test shall verify that contents of messages used for the Group Registration are correct, and that the unit under test correctly responds to these messages. (Multi Trunked System only)

The Group Registration process is initiated when a user selects another Group ID or attempts to transmit using a non-registered Group ID. This test shall be done in a case when a user selects another Group ID.

Figure 5.1-4 shows the configuration diagram for testing. The following 10 types of messages shall be applied.

Table 5.1-31 : ISM INFO4 message

Table 5.1-32 : OSM INFO4 (Busy Repeater Message) message

Table 5.1-33 : OSM INFO4 (Free Repeater Message) message

Table 5.1-34 : OSM INFO4 / INFO2 (Site ID Message Message) message

Table 5.1-35 : ISM / OSM INFO4 (EOT) message

Table 5.1-36 : CALL_REQ message from SU

Table 5.1-37 : CALL_RESP message from Interoperability Tester

Table 5.1-40 : TX_REL(Inbound) message from SU

Table 5.1-44 : GRP_REG_REQ message from SU

Table 5.1-45 : GRP_REG_RESP message from Interoperability Tester

5.1.20.1. Group Registration Accept

- (1) Be sure to make SU an idle mode in which Registration process has been completed.
- (2) When the other Group ID has been selected, verify that the SU transmits a "CALL_REQ" message shown in Table 5.1-6 that includes a "INFO4" message shown in Table 5.1-31 in SCCH.
- (3) When a "CALL_RESP" message shown in Table 5.1-37 which includes any of "INFO4" messages shown in Table 5.1-32 to Table 5.1-34 in SCCH is transmitted from Interoperability Tester, verify that the SU sends "GRP_REG_REQ" message shown in Table 5.1-38 which includes "INFO4" message shown in Table 5.1-31 in SCCH.
- (4) When a "GRP_REG_RESP" message indicating "Accept" shown in Table 5.1-45 which includes any of "INFO4" messages shown in Table 5.1-32 to Table 5.1-34 in SCCH is transmitted from Interoperability Tester, verify that the SU sends "TX_REL(Inbound)" message shown in Table 5.1-38 which includes "INFO4(EOT)" message shown in Table 5.1-35, and then shifts its channel frequency to the channel frequency of the Home repeater.

5.1.20.2. Group Registration Fail

- (1) Be sure to make SU an idle mode in which Registration process has been completed.
- (2) When the other Group ID has been selected, Verify that the SU transmits a "CALL_REQ" message shown in Table 5.1-6 that includes a "INFO4" message shown in Table 5.1-31 in SCCH.
- (3) When a "CALL_RESP" message shown in Table 5.1-37 which includes any of "INFO4" messages shown in Table 5.1-32 to Table 5.1-34 in SCCH is transmitted from Interoperability Tester, verify that the SU sends "GRP_REG_REQ" message shown in Table 5.1-38 which includes "INFO4" message shown in Table 5.1-31 in SCCH.
- (4) When a "GRP_REG_RESP" message indicating "Fail" shown in Table 5.1-45 which includes any of "INFO4" messages shown in Table 5.1-32 to Table 5.1-34 in SCCH is transmitted from Interoperability Tester, verify that the SU sends "TX_REL(Inbound)" message shown in Table 5.1-38 which includes "INFO4(EOT)" message shown in Table 5.1-35, and then becomes idle mode or "Collect Repeater" acquisition mode.

5.1.20.3. Group Registration Refuse

- (1) Be sure to make SU an idle mode in which Registration process has been completed.
- (2) When the other Group ID has been selected, Verify that the SU transmits a "CALL_REQ" message shown in Table 5.1-6 that includes a "INFO4" message shown in Table 5.1-31 in SCCH.
- (3) When a "CALL_RESP" message shown in Table 5.1-37 which includes any of "INFO4" messages shown in Table 5.1-32 to Table 5.1-34 in SCCH is transmitted from Interoperability Tester, verify that the SU sends "GRP_REG_REQ" message shown in Table 5.1-38 which includes "INFO4" message shown in Table 5.1-31 in SCCH.
- (4) When a "GRP_REG_RESP" message indicating "Refuse" shown in Table 5.1-45 which includes any of "INFO4" messages shown in Table 5.1-32 to Table 5.1-34 in SCCH is transmitted from Interoperability Tester, verify that the SU sends "TX_REL" message shown in Table 5.1-38 which includes "INFO4(EOT)" message shown in Table 5.1-35, and then becomes idle mode or "Collect Repeater" acquisition mode.

Table 5.1-44 GRP_REG_REQ message

Group Registration Option	00
Source Prefix	Prefix Number of SU
Source Unit ID	Unit ID of SU
Group Prefix	Selected Group Prefix Number
Group ID	Selected Group ID

Table 5.1-45 GRP_REG_RESP message

Group Registration Option	00
Source Prefix	Prefix Number of SU
Source Unit ID	Unit ID of SU
Group Prefix	Selected Group Prefix Number
Group ID	Selected Group ID
Cause(MM)	01(Accept) / 06(Fail) / 08(Refuse)

5.1.21. Authentication Tests

This test shall verify that contents of messages used for the Authentication process are correct, and that the unit under test correctly responds to these messages. (Multi Trunked System only)

This test includes the test methods for the following two Authentication processes:

- (1) Authentication during Registration Process
- (2) Authentication in normal process

Procedure (1) represents a case that a TR sends a request for Authentication while an SU is doing the Registration process, and Procedure (2) represents a case that a TR sends a request for Authentication to an SU which has completed the Registration process.

Figure 5.1-4 shows the configuration diagram for testing. The following 12 types of messages shall be applied.

- Table 5.1-31 : ISM INFO4 message
- Table 5.1-32 : OSM INFO4 (Busy Repeater Message) message
- Table 5.1-33 : OSM INFO4 (Free Repeater Message) message
- Table 5.1-34 : OSM INFO4 / INFO2 (Site ID Message Message) message
- Table 5.1-35 : ISM / OSM INFO4 (EOT) message
- Table 5.1-36 : SU \emptyset CALL_REQ message from SU
- Table 5.1-37 : CALL_RESP message from Interoperability Tester
- Table 5.1-38 : REG_REQ message from SU
- Table 5.1-39 : REG_RESP message from Interoperability Tester
- Table 5.1-40 : TX_REL(Inbound) message from SU
- Table 5.1-46 : AUTH_INQ_REQ message from Interoperability Tester
- Table 5.1-47 : AUTH_INQ_RESP message from SU

5.1.21.1. Authentication during Registration Process

- (1) Carry out operations of (1), (2) and (3) shown in Section 5.1.17.1.
- (2) When an AUTH_INQ_REQ message shown in Table 5.1-46 which includes any of "INFO4" messages shown in Table 5.1-32 to Table 5.1-34 in SCCH is transmitted from Interoperability Tester, verify that the SU sends "AUTH_INQ_RESP" message shown in Table 5.1-38 which includes "INFO4" message shown in Table 5.1-31 in SCCH.
- (3) When a "REG_RESP" message indicating "Accept" shown in Table 5.1-38 is transmitted from Interoperability Tester, verify that the SU sends "TX_REL(Inbound)" message shown in Table 5.1-38 which includes "INFO4(EOT)" message shown in Table 5.1-35, and then shifts its channel frequency to the channel frequency of the Home repeater.

5.1.21.2. Authentication Inquiry by Trunking Repeater

- (1) Keep an SU in the idle state after the Registration process.
- (2) When AUTH_INQ_REQ message shown in Table 5.1-46 which includes any of “INFO4” messages shown in Table 5.1-32 to Table 5.1-34 in SCCH is transmitted from Interoperability Tester, verify that the SU sends “AUTH_INQ_RESP” message shown in Table 5.1-38 which includes “INFO4” message shown in Table 5.1-31 in SCCH.

Table 5.1-46 AUTH_INQ_REQ message

Authentication Option	00
Source Prefix	00000b
Source Unit ID	7FB as TC ID
Destination Prefix	Prefix Number of SU
Destination Unit ID	Unit ID of SU
Authentication Parameter	Any value
System ID Option	10000b / 01000b
System ID	Value of System ID

Table 5.1-47 AUTH_INQ_RESP message

Authentication Option	00
Source Prefix	Prefix Number of SU
Source Unit ID	Unit ID of SU
Destination Prefix	00000b
Destination Unit ID	7FB as TC ID
Authentication Value	Depends on ESN and Authentication Parameter of the SU
System ID Option	10000b / 01000b
System ID	Value of System ID

5.1.22. System Data Write Tests

In this test, we evaluate the validity of the description of a message used in System Data Write process, and verify whether or not SU operates as intended in response to those messages. (Multi Trunked System only)

This test includes the following 2 varieties of procedural steps to follow in executing System Data Write process.

- (1) System Data Write during Registration Process
- (2) System Data Write by Trunking Repeater

(1) is the case in which system data communication will be carried out with a SU that has not completed the Registration Process. On the other hand, (2) is the case in which system data communication will be carried out with a SU that has already completed the Registration Process.

Figure 5.1-4 shows the configuration diagram for testing.

The following 12 types of messages shall be applied.

- Table 5.1-31 : ISM INFO4 message
- Table 5.1-32 : OSM INFO4 (Busy Repeater Message) message
- Table 5.1-33 : OSM INFO4 (Free Repeater Message) message
- Table 5.1-34 : OSM INFO4 / INFO2 (Site ID Message Message) message
- Table 5.1-35 : ISM / OSM INFO4 (EOT) message
- Table 5.1-36 : CALL_REQ message from SU
- Table 5.1-37 : CALL_RESP message from Interoperability Tester
- Table 5.1-38 : REG_REQ message from SU
- Table 5.1-39 : REG_RESP message from Interoperability Tester
- Table 5.1-40 : TX_REL(Inbound) message from SU
- Table 5.1-48 : DWR (Header) message from Interoperability
- Table 5.1-49 : DWR_ACK message from SU

5.1.22.1. System Data Write during Registration Process

- (1) Carry out operations of (1), (2) and (3) shown in Section 5.1.17.1.
- (2) When a DWR(Header) and DWR(System Data) message shown in Table 5.1-48 which include any of "INFO4" messages shown in Table 5.1-32 to Table 5.1-34 in SCCH are transmitted from Interoperability Tester, verify that the SU sends "DWR_ACK" message shown in Table 5.1-38 which includes "INFO4" message shown in Table 5.1-31 in SCCH.
- (3) When a "REG_RESP" message indicating "Accept" shown in Table 5.1-38 is transmitted from Interoperability Tester, verify that the SU sends "TX_REL(Inbound)" message shown in Table 5.1-38 which includes "INFO4(EOT)" message shown in Table 5.1-35, and then shifts its channel frequency to the channel frequency of the Home repeater.

5.1.22.2. System Data Write by Trunking Repeater

- (1) Keep an SU in the idle state after the Registration process.
- (2) When a DWR(Header) and a DWR(System Data) message shown in Table 5.1-48 which include any of "INFO4" messages shown in Table 5.1-32 to Table 5.1-34 in SCCH are transmitted from Interoperability Tester, verify that the SU sends "DWR_ACK" message shown in Table 5.1-38 which includes "INFO4" message shown in Table 5.1-31 in SCCH.

Table 5.1-48 DWR (Header) message

Data Write Option	00
Source Prefix	00000b
Source Unit ID	7FB as TC ID
Destination Prefix	Prefix of SU
Destination Unit ID	Unit ID of SU
Packet Information	Except for the following, depends on the format to be used for testing. Delivery Flag = 0 Unconfirmed (Group Call, Individual Call) Delivery Flag = 1 Confirmed (Individual Call)

Table 5.1-49 DWR_ACK message

Data Write Option	00
Source Prefix	Prefix of SU
Source Unit ID	Unit ID of SU
Destination Prefix	00000b
Destination Unit ID	7FB as TC ID
Response Information	00 001b (Receive Success)
Error Block Flag	0000

5.1.23. Site Roaming Test

This test shall verify that an SU initiates RF Traffic channel hunting and performs Registration on an acquired RTCH2 of another site, when the SU becomes unable to receive an RTCH2 signal of the site where the SU completed its Registration. (Trunked System only)

Figure 5.1-5 shows the configuration diagram for testing. Interoperability tester No.1 is treated as site 1, and interoperability tester No.2 is treated as site 2. Each RF Traffic channel is treated as RTCH2-1 or RTCH2-2.

Prior to testing, two RF Traffic channels, RTCH2-1 and RTCH2-2 shall be configured for an SU.

Table 5.1-50 shows parameters of Location ID for site 1 and site 2.

	Site 1	Site 2
System Code	1	1
Site Type	11b	11b
Site Code	1	2

- (1) Set the attenuation level of attenuator 1 so that the receiver input level is a sufficient level in which SU can acquire an RTCH2-1, and set the attenuation level of attenuator 2 so that the receiver input level is an insufficient level in which SU cannot acquire an RTCH2-2.
- (2) Keep SU in the idle state on an RTCH2-1 after completion of registration with interoperability tester No. 1.
- (3) Increase the attenuation level of attenuator 1 until SU cannot receive outbound signals on an RTCH2-1, and decrease the attenuation level of attenuator 2 until SU can receive outbound signals on an RTCH2-2.
- (4) Verify that SU moves to "RTCH2-2" and then executes the procedure shown in Section 5.1.17.1.

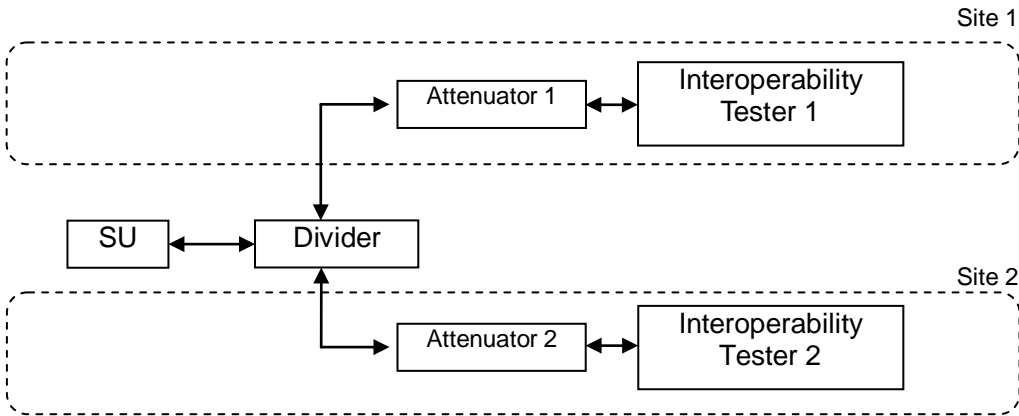

Figure 5.1-5 Site Roaming Test Setup

5.1.24. Halt Repeater Test

In this test, we verify whether or not a SU operates as intended in the case in which the SU has received a Halt Repeater Message.

The connection configuration of this test is shown in Figure 5.1-4. A Halt Repeater function is affected by specifications of a system, therefore it will be good enough that any one of the following items to be confirmed is checked.

Verify whether a SU properly judges that a TRS has restored its normal operation in any of the following cases.

- (1) In the case in which any specified period of time has passed since a Halt Repeater Message shown in Table 5.1-51 was received, or;
- (2) In the case in which criteria stipulated by a manufacturer of SU has been met.

Table 5.1-51 OSM INFO4 (Halt Repeater Message) message

Structure	00b
Area	Value of Area
Free Repeater1	Value of Free Repeater number
Free Repeater1	Value of Free Repeater number
ID	7FD (2045)

5.1.25. ID Validation Test

A test method to check ID Validation function is the same as Link Tests shown in 5.1.1. Each of the test methods to see whether or not SU operates as intended in response to a valid ID or an invalid ID is shown in 5.1.1.1. and 5.1.1.2, respectively.

5.2. TR Testing

5.2.1. Idle Message Test

(Multi Trunked System only)

5.2.1.1. Idle Repeater Message Test

After finishing transmission, if TR is not in use anymore, it sends Idle Repeater Message and TX_REL Frame to all the SUs configured as Home Repeater in order to notify the TR is within the communication area.

This test confirms if the message contents is correctly sent.

Figure 5.2-1 shows the configuration diagram for testing.

The following 3 types of messages shall be applied.

Table 5.2-1 : OSM INFO4 (Idle Repeater Message) message

Table 5.2-2 : IDLE message

Table 5.2-3 : TX_REL (Outbound) message

- (1) Turn TR on, and transmit on Home Repeater.
- (2) Analyze the contents of the message by interoperability tester and compare it with the contents shown in Table 5.2-1 and Table 5.2-2.

Interval of message transmissions is not specified.

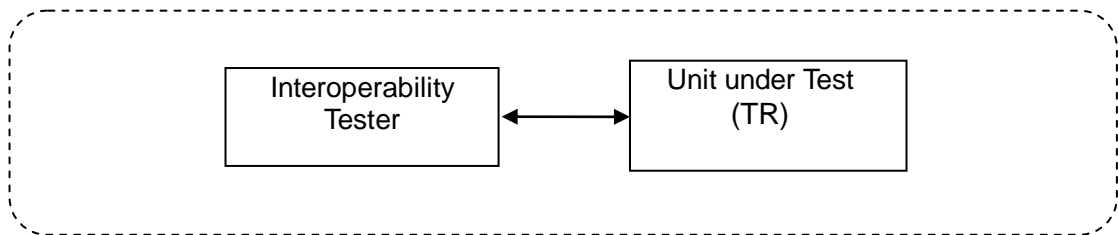

Figure 5.2-1 Idle Message Tests Setup

Table 5.2-1 OSM INFO4 (Idle Repeater Message) message

Structure	00b (INFO4)
Area	Value of Area
Repeater Number1	Value of Repeater number
Repeater Number2	Value of Repeater number
ID	7FE

Table 5.2-2 IDLE message

Message Type	010000b
--------------	---------

Table 5.2-3 TX_REL(Outbound) message

	Single Trunked System	Multi Trunked System
CC Option	00	10
Call Type	010b (Unspecified)	
Free Repeater	Any value in the range of 00001b-11110b	
Source	Home Repeater Value of Home Repeater number 000	
Destination	00000b	00000b
	000	

5.2.1.2. Site ID Message Test

Multi Trunked System needs to notify information to identify a site so that SU can perform roaming. As site identification information, Site ID Message and TX_REL are transmitted. This test confirms if the message contents is correctly sent.

Figure 5.2-1 shows the configuration diagram for testing.

The following 5 types of messages shall be applied.

Table 5.2-1 : OSM INFO4 (Idle Repeater Message) message

Table 5.2-3 : TX_REL (Outbound) message

Table 5.2-4 : OSM INFO4 (Site ID Message Message) message

Table 5.2-5 : SRV_INFO message

Table 5.2-6 : ADJ_SITE_INFO message

- (1) Turn TR on, and transmit on Home Repeater.
- (2) Analyze the contents of the message by interoperability tester and compare it with the contents shown in Table 5.2-1, Table 5.2-3, Table 5.2-4, Table 5.2-5 and Table 5.2-6.

Interval of message transmissions is not specified.

Table 5.2-4 OSM INFO4 (Site ID Message) message

Structure	00b (INFO4)
Area	Value of Area
Site Type	Value of Site Type
Site Code	Value of Site Code
ID	7F9

Table 5.2-5 SRV_INFO message

System ID	Value of System ID
Site Code	Value of Site Code
Service Information	Depending on the test configuration
Restriction Information	Depending on the test configuration

Table 5.2-6 ADJ_SITE_INFO message

Adjacent Site Option (1)	Depending on the test configuration
Adjacent Site System ID (1)	
Adjacent Site Code (1)	
Adjacent Site Option (2)	
Adjacent Site System ID (2)	
Adjacent Site Code (2)	

5.2.2. Link Tests

In this test, we evaluate the validity of the description of the messages used in Link establishment operation prior to other operations including Call, and verify whether or not SU operates as intended in response to those messages.

The connection configuration of this test is shown in Figure 5.2-2. Suppose the interoperability tester No.1 as calling SU, and the interoperability tester No.2 as called SU.

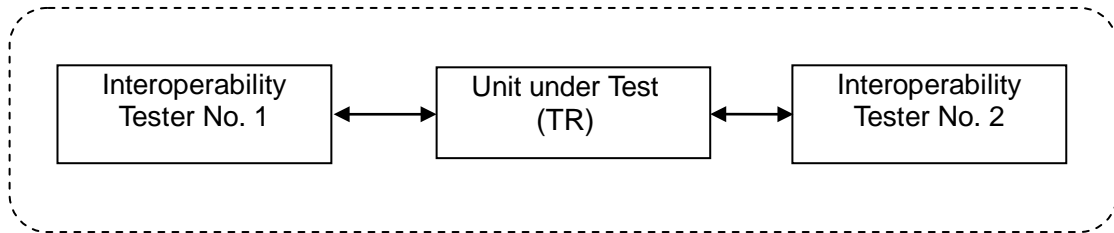

Figure 5.2-2 Link Tests Setup

The following 10 types of messages shall be applied.

- Table 5.2-7 : ISM INFO4 / INFO2 message
- Table 5.2-8 : OSM INFO4 / INFO2 (Busy Repeater Message) message
- Table 5.2-9 : OSM INFO4 / INFO2 (Free Repeater Message) message
- Table 5.2-10 : OSM INFO4 / INFO2 (Site ID Message Message) message
- Table 5.2-11 : ISM / OSM INFO4 (EOT) message
- Table 5.2-12 : CALL_REQ message from Interoperability Tester
- Table 5.2-13 : CALL_CONN_RESP message from TR
- Table 5.2-14 : CALL_RESP message from TR
- Table 5.2-15 : TX_REL(Inbound) message from Interoperability Tester
- Table 5.2-16 : TX_REL(Outbound) message from TR

5.2.2.1. Link Accept Test

This Section shows the case in which a link is established successfully.

- (1) To transmit a message "OSM INFO4 / INFO2" (Free Repeater Message) shown in Table 5.2-9 from TR, whereby informs the Interoperability Tester 1 that the Home repeater for the SU is Free Repeater.
- (2) When "CALL_REQ" message shown in Table 5.2-12 that includes "INFO4" message shown in Table 5.2-7 in SCCH is transmitted from Interoperability Tester, verify that a message "CALL_CONN_RESP" shown in
- (3) Table 5.1-10 indicating "a queue not specifying any other cause" that includes any of "INFO4" messages shown in Table 5.1-5 to Table 5.2-10 in SCCH is transmitted from TR.
- (4) When a Link connection has become allowed, verify that a message "CALL_RESP" shown in
- (5) Table 5.1-10 that includes any of "INFO4" messages shown in Table 5.1-5 to Table 5.2-10 in SCCH is transmitted from TR.

5.2.2.2. Link Refuse

This Section shows the case in which link establishment is rejected.

- (1) To transmit a message "OSM INFO4 / INFO2" (Free Repeater Message) shown in Table 5.2-9 from TR, whereby informs the Interoperability Tester 1 that the Home repeater for the SU is Free Repeater.
- (2) When "CALL_REQ" message shown in Table 5.2-12 that includes "INFO4" message shown in Table 5.2-7 in SCCH is transmitted from Interoperability Tester 1, verify that a message "CALL_CONN_RESP" shown in
- (3) Table 5.1-10 indicating "refuse" that includes any of "INFO4" messages shown in Table 5.1-5 to Table 5.2-10 in SCCH is transmitted from TR.
- (4) When "TX_REL" (Inbound) shown in Table 5.2-15 that includes "EOT" shown in Table 5.1-2 in SCCH has been transmitted from the Interoperability Tester 1, verify that TR transmits "TX_REL"(Outbound) shown in Table 5.2-16 that includes "EOT" shown in Table 5.1-2 in SCCH.

5.2.2.3. Link of Traffic Repeater

This Section shows a test method in which Link operation is performed via a TR whose channel frequency is that of any of repeaters other than the Home repeater.

- (1) To transmit a message "OSM INFO4 / INFO2" (Free Repeater Message) shown in Table 5.2-9 from TR, whereby informs the Interoperability Tester 1 that the non-Home repeater for the SU is Free Repeater.
- (2) When a message "CALL_REQ" shown in
- (3) Table 5.1-10 that includes an "INFO4" message shown in Table 5.1-5 in SCCH has been transmitted from the interoperability Tester to the non-Home repeater as Free Repeater as instructed in (1), verify that a message "CALL_CONN_RESP" shown in
- (4) Table 5.1-10 indicating "a queue not specifying any other cause" that includes any of "INFO4" messages shown in Table 5.1-5 to Table 5.2-10 in SCCH is transmitted from TR..
- (5) When a Link connection has become allowed, verify that a message "CALL_RESP" shown in
- (6) Table 5.1-10 that includes "INFO4" messages shown in Table 5.2-8 in SCCH is transmitted from TR.

Table 5.2-7 ISM INFO4 / INFO2 message

	Single Trunked System	Multi Trunked System
Structure	00b (INFO4) 10b (INFO2)	
Area	Value of Area	
Repeater in Use	Value of Use Repeater number	
Destination	Home Repeater Value of Home Repeater number	Destination Prefix Value of Destination Prefix
	Group ID (Group Call) Unit ID of Interoperability Tester 2 (Individual Call) ID=7FF (All Call)	
G/U	Group=0b/Unit=1b (Destination ID)	

Table 5.2-8 OSM INFO4 / INFO2 (Busy Repeater Message) message

	Single Trunked System	Multi Trunked System
Structure	00b (INFO4) 10b (INFO2)	
Area	Value of Area	
Go to Repeater	Value of Go to Repeater number	
Destination	Home Repeater Value of Home Repeater number	Destination Prefix Value of Destination Prefix
	Group ID (Group Call) Unit ID of Interoperability Tester 2 (Individual Call) ID=7FF (All Call)	
G/U	Group=0b/Unit=1b (Destination ID)	

Table 5.2-9 OSM INFO4 / INFO2 (Free Repeater Message) message

	Single Trunked System	Multi Trunked System
Structure	00b (INFO4) 10b (INFO2)	
Area	Value of Area	
Free Repeater1	Value of Free Repeater number (NOTE: use a channel frequency which is idle for communication)	
Free Repeater2	Value of Free Repeater number (NOTE: use a channel frequency which is idle for communication)	
ID	7FC	

Table 5.2-10 OSM INFO4 / INFO2 (Site ID Message) message

	Single Trunked System	Multi Trunked System
Structure	-	00b (INFO4) 10b (INFO2)
Area	-	Value of Area
Site Type	-	Value of Site Type
Site Code	-	Value of Site Code
ID	-	7F9

Table 5.2-11 ISM / OSM INFO4 (EOT) message

	Single Trunked System	Multi Trunked System
Structure	00b (INFO4) 10b (INFO2)	
Area	Value of Area	
Repeater in Use	11111b	
Destination	Home Repeater Value of Home Repeater number	Destination Prefix Value of Destination Prefix
	Group ID (Group Call) Unit ID of Interoperability Tester 2 (Individual Call) ID=7FF (All Call)	
G/U	Group=0b/Unit=1b (Destination ID)	

Table 5.2-12 CALL_REQ message

	Single Trunked System	Multi Trunked System
CC Option	00 (Individual Call, Group Call, All Call) 80 (Emergency Call)	10 (Individual Call, Group Call, All Call) 90 (Emergency Call)
Call Type	100b (Individual Call) 001b (Conference Group Call / All Call) 000b (Broadcast Call)	
Source	Home Repeater Value of Home Repeater number	Source Prefix Prefix of Interoperability Tester 1
	Unit ID of Interoperability Tester 1	
Destination	Home Repeater Value of Home Repeater number	Destination Prefix Value of Destination Prefix
	Group ID (Group Call) Unit ID of Interoperability Tester 2 (Individual Call) ID=7FF (All Call)	
System ID Option	-	10000b / 01000b
System ID	-	Value of System ID

Table 5.2-13 CALL_CONN_RESP message

	Single Trunked System	Multi Trunked System
CC Option	00 (Individual Call, Group Call, All Call) 80 (Emergency Call)	10 (Individual Call, Group Call, All Call) 90 (Emergency Call)
Call Type	100b (Individual Call) 001b (Conference Group Call / All Call) 000b (Broadcast Call)	
Source	Home Repeater Value of Home Repeater number	Source Prefix Prefix of Interoperability Tester 1
	Unit ID of Interoperability Tester 1	
Destination	Home Repeater Value of Home Repeater number	Destination Prefix Value of Destination Prefix
	Group ID (Group Call) Unit ID of Interoperability Tester 2 (Individual Call) ID=7FF (All Call)	
Cause (VD)	0111111b (a queue not specifying any other cause) 0010010b (a service of a calling SU is not allowed.)	
System ID Option	-	10000b / 01000b
System ID	-	Value of System ID

Table 5.2-14 CALL_RESP message

	Single Trunked System	Multi Trunked System
CC Option	00 (Individual Call, Group Call, All Call) 80 (Emergency Call)	10 (Individual Call, Group Call, All Call) 90 (Emergency Call)
Call Type	100b (Individual Call) 001b (Conference Group Call / All Call) 000b (Broadcast Call)	
Free Repeater	Any value in the range of 00001b-11110b	
Source	Home Repeater Value of Home Repeater number	Source Prefix Prefix of Interoperability Tester 1
	Unit ID of Interoperability Tester 1	
Destination	Home Repeater Value of Home Repeater number	Destination Prefix Value of Destination Prefix
	Group ID (Group Call) Unit ID of Interoperability Tester 2 (Individual Call) ID=7FF (All Call)	
System ID Option	-	10000b / 01000b
System ID	-	Value of System ID

Table 5.2-15 TX_REL(Inbound) message

	Single Trunked System	Multi Trunked System
CC Option	00 (Individual Call, Group Call, All Call) 80 (Emergency Call)	10 (Individual Call, Group Call, All Call) 90 (Emergency Call)
Call Type	100b (Individual Call) 001b (Conference Group Call / All Call) 000b (Broadcast Call)	
Source	Home Repeater Value of Home Repeater number	Source Prefix Prefix of Interoperability Tester 1
	Unit ID of Interoperability Tester 1	
Destination	Home Repeater Value of Home Repeater number	Destination Prefix Value of Destination Prefix
	Group ID (Group Call) Unit ID of Interoperability Tester 2 (Individual Call) ID=7FF (All Call)	

Table 5.2-16 TX_REL(Outbound) message

	Single Trunked System	Multi Trunked System
CC Option	00 (Individual Call, Group Call, All Call) 80 (Emergency Call)	10 (Individual Call, Group Call, All Call) 90 (Emergency Call)
Call Type	100b (Individual Call) 001b (Conference Group Call / All Call) 000b (Broadcast Call)	
Free Repeater	Any value in the range of 00001b-11110b	
Source	Home Repeater Value of Home Repeater number	Source Prefix Prefix of Interoperability Tester 1
	Unit ID of Interoperability Tester 1	
Destination	Home Repeater Value of Home Repeater number	Destination Prefix Value of Destination Prefix
	Group ID (Group Call) Unit ID of Interoperability Tester 2 (Individual Call) ID=7FF (All Call)	

5.2.3. Group Voice Call Tests

This test shall verify that contents of messages used for Group Voice Call are correct, and that the unit under test correctly responds to these messages.

This test includes the test methods for the following two modes:

- (1) Conference Group Call
- (2) Broadcast Group Call

Figure 5.2-2 shows the configuration diagram for testing.

Each test shall be performed in the condition that the calling SU is Interoperability tester No. 1 and the called SU is Interoperability tester No. 2.

The following 15 types of messages shall be applied.

- Table 5.2-7 : ISM INFO4 / INFO2 message
- Table 5.2-8 : OSM INFO4 / INFO2 (Busy Repeater Message) message
- Table 5.2-9 : OSM INFO4 / INFO2 (Free Repeater Message) message
- Table 5.2-10 : OSM INFO4 / INFO2 (Site ID Message Message) message
- Table 5.2-11 : ISM / OSM INFO4 (EOT) message
- Table 5.2-12 : CALL_REQ message from Interoperability Tester
- Table 5.2-13 : CALL_CONN_RESP message from TR
- Table 5.2-14 : CALL_RESP message from TR
- Table 5.2-15 : TX_REL(Inbound) message from Interoperability Tester
- Table 5.2-16 : TX_REL(Outbound) message from TR
- Table 5.2-17 : ISM INFO3 message
- Table 5.2-18 : ISM INFO1 message
- Table 5.2-19 : OSM INFO3 message
- Table 5.2-20 : OSM INFO1 message
- Table 5.2-21 : VCALL message from Interoperability Tester

5.2.3.1. Conference Group Call Test

In this test, parameters for messages to be used shall apply the values for Conference Group Call.

5.2.3.1.1. Group Call Success

- (1) Link connection will be shown in Section 5.2.2.
- (2) When "VCALL" message shown in Table 5.2-15 that includes "INFO4" message shown in Table 5.1-2 in SCCH has been transmitted from the Interoperability Tester 1, verify that TR relays the message, and transmits a "VCALL" message that includes any of "INFO4" messages shown in Table 5.1-2 to 5.2-10 in SCCH.
- (3) Verify that voice data that sequentially includes INFO1 to INFO4 messages shown in Table 5.2-7, Table 5.2-17 and Table 5.2-18 in SCCH are transmitted via TCH2 from Interoperability Tester 1, the Interoperability Tester 2 receives the voice data relayed by TR and outputs the decoded audio.
Verify that INFO2 and INFO4 messages transmitted from TR agree with to any of the messages shown in Table 5.2-8 to Table 5.2-10.
Furthermore, verify that each of the INFO1 and INFO3 messages corresponds to that message shown in Table 5.2-8 and Table 5.2-10, respectively.
- (4) When a "TX_REL"(Inbound) message shown in Table 5.2-15 that includes "INFO4(EOT)" message shown in Table 5.1-2 in SCCH is transmitted from the Interoperability Tester 1, verify that a "TX_REL"(Outbound) message shown in Table 5.2-15 that includes "INFO4(EOT)" message shown in Table 5.1-2 in SCCH is transmitted via RTCH2.

5.2.3.2. Broadcast Group Call Test

In this test, parameters for messages to be used shall apply the values for Broadcast Group Call.

Testing identical to that done for Conference Group Call as described in Section 5.2.3.1 shall be done.

Table 5.2-17 ISM INFO3 message

	Single Trunked System	Multi Trunked System
Structure	01b	
Area	Value of Area	
Repeater in Use	Value of Use Repeater number	
Source	Home Repeater Value of Home Repeater number	Source Prefix Prefix of Interoperability Tester 1
	Unit ID of Interoperability Tester 1	

Table 5.2-18 ISM INFO1 message

	Single Trunked System	Multi Trunked System
Structure	11b	
Area	Value of Area	
Repeater in Use	Value of Use Repeater number	
Pass Character	11111b	
Call Option	000b (Individual Call, Group Call, All Call)	010b (Individual Call, Group Call, All Call)
	100b (Emergency Call)	110b (Emergency Call)
Cipher Type	00b	
Key ID	000000b	

Table 5.2-19 OSM INFO3 message

	Single Trunked System	Multi Trunked System
Structure	01b	
Area	Value of Area	
Free Repeater1	Value of Free Repeater number	
Source	Home Repeater Value of Home Repeater number	Source Prefix Prefix of Interoperability Tester 1
	Unit ID of Interoperability Tester 1	

Table 5.2-20 OSM INFO1 message

	Single Trunked System	Multi Trunked System
Structure	11b	
Area	Value of Area	
Free Repeater1	Value of Free Repeater number	
Free Repeater2	Value of Free Repeater number	
Call Option	000b (Individual Call, Group Call, All Call)	010b (Individual Call, Group Call, All Call)
	100b (Emergency Call)	110b (Emergency Call)
Cipher Type	00b	
Key ID	000000b	

Table 5.2-21 VCALL message

	Single Trunked System	Multi Trunked System
CC Option	00 (Individual Call, Group Call, All Call) 80 (Emergency Call)	10 (Individual Call, Group Call, All Call) 90 (Emergency Call)
Call Type	100b (Individual Call) 001b (Conference Group Call / All Call) 000b (Broadcast Call)	
Source	Home Repeater Value of Home Repeater number	Source Prefix Prefix of Interoperability Tester 1
	Unit ID of Interoperability Tester 1	
Destination	Home Repeater Value of Home Repeater number	Destination Prefix Value of Destination Prefix
	Group ID (Group Call) Unit ID of Interoperability Tester .2 (Individual Call) ID=7FF (All Call)	
Cipher Type	00b	
Key ID	000000b	

5.2.4. Individual Voice Call Tests

This test shall verify that contents of messages used for Individual Voice Call are correct, and that the unit under test correctly responds to these messages.

- (1) In the case that the availability of the called SU is not verified and a voice call transmission on an RTCH2 is started from the calling SU

Figure 5.2-2 shows the configuration diagram for testing. Each test shall be performed in the condition that the calling SU is Interoperability tester No. 1 and the called SU is Interoperability tester No. 2.

The following 15 types of messages shall be applied.

- Table 5.2-7 : ISM INFO4 / INFO2 message
- Table 5.2-8 : OSM INFO4 / INFO2 (Busy Repeater Message) message
- Table 5.2-9 : OSM INFO4 / INFO2 (Free Repeater Message) message
- Table 5.2-10 : OSM INFO4 / INFO2 (Site ID Message Message) message
- Table 5.2-11 : ISM / OSM INFO4 (EOT) message
- Table 5.2-12 : CALL_REQ message from Interoperability Test
- Table 5.2-13 : CALL_CONN_RESP message from TR
- Table 5.2-14 : CALL_RESP message from TR
- Table 5.2-15 : TX_REL(Inbound) message from Interoperability Tester
- Table 5.2-16 : TX_REL(Outbound) message from TR
- Table 5.2-17 : ISM INFO3 message
- Table 5.2-18 : ISM INFO1 message
- Table 5.2-19 : OSM INFO3 message
- Table 5.2-20 : OSM INFO1 message
- Table 5.2-21 : VCALL message from Interoperability Tester

Values for Individual Call shall be applied to parameters for each table.

5.2.4.1. Individual Call Test

Testing identical to that done for Conference Group Call as described in Section 5.2.3.1 shall be done.

In this test, parameters for messages to be used shall apply the values for Individual Call.

5.2.5. All Call Test

In this test, parameters for messages to be used shall apply the values for Individual Call.

Figure 5.2-2 shows the configuration diagram for testing.

Testing identical to that done for Conference Group Call as described in Section 5.2.3.1 shall be done.

In this test, parameters for messages to be used shall apply the values for All Call.

5.2.6. Short Data Call Tests

This test shall verify that contents of messages used for the Short Data Call are correct, and that the unit under test correctly responds to these messages.

This test includes the test methods for the following two modes.

- (1) Broadcast Short Data Call
- (2) Unit to Unit Short Data Call

Figure 5.2-2 shows the configuration diagram for testing.

The following 12 types of messages shall be applied.

Table 5.2-7 : ISM INFO4 / INFO2 message

Table 5.2-8 : OSM INFO4 / INFO2 (Busy Repeater Message) message

Table 5.2-9 : OSM INFO4 / INFO2 (Free Repeater Message) message

Table 5.2-10 : OSM INFO4 / INFO2 (Site ID Message Message) message

Table 5.2-11 : ISM / OSM INFO4 (EOT) message

Table 5.2-12 : CALL_REQ message from Interoperability Tester

Table 5.2-13 : CALL_CONN_RESP message from TR

Table 5.2-14 : CALL_RESP message from TR

Table 5.2-15 : TX_REL(Inbound) message from Interoperability Tester

Table 5.2-16 : TX_REL(Outbound) message from TR

Table 5.2-22 : SDCALL_REQ(Header) message

Table 5.2-23 : SDCALL_RESP message

SDCALL_REQ (User Data) messages are recommended to be constructed with User Data not exceeding 100 bytes. No contents of User Data are specified in this document.

5.2.6.1. Broadcast Short Data Call Test

In this test, parameters for messages to be used shall apply the values for Group Call.

5.2.6.1.1. Short Data Success

- (1) Link connection will be shown in Section 5.2.2.
- (2) When "SDCALL_REQ"(Header) message shown in Table 5.2-15 that includes "INFO4" message shown in Table 5.1-2, and "SDCALL_REQ"(User Data) have been transmitted from the Interoperability Tester 1, verify that TR also transmits the same "SDCALL_REQ(Header)" and "SDCALL_REQ(User Data)" messages that have been transmitted from the Interoperability Tester 1. Provided however that be sure to SCCH has been replaced with INFO4 message shown in Table 5.2-8 to Table 5.2-10. The procedural steps to follow in substitution of INFO4 will not be described.
- (3) When a "TX_REL"(Inbound) message shown in Table 5.2-15 that includes an "INFO4(EOT)" message shown in Table 5.1-2 in SCCH has been transmitted from the Interoperability Tester 1, verify that TR transmits a "TX_REL"(Outbound) message shown in Table 5.2-15 that includes "INFO4(EOT)" message shown in Table 5.1-2 in SCCH.
- (4) Verify that the short data which has been transmitted by TR and then received by the Interoperability Tester 2 is correct.

5.2.6.2. Unit to Unit Short Data Call Test

5.2.6.2.1. Short Data Success

- (1) Link connection will be shown in Section 5.2.2.
- (2) When "SDCALL_REQ"(Header) message shown in Table 5.2-15 that includes "INFO4" message shown in Table 5.1-2 in SCCH, and "SDCALL_REQ"(User

Data) have been transmitted from the Interoperability Tester 1, verify that TR also transmits the same "SDCALL_REQ(Header)" and "SDCALL_REQ(User Data)" messages that have been transmitted from the Interoperability Tester 1. Provided however that be sure to SCCH has been replaced with INFO4 message shown in Table 5.2-8 to Table 5.2-10. The procedural steps to follow in substitution of INFO4 will not be described.

- (3) Verify that the data which has been relayed by the TR and then received by the Interoperability Tester 2 is correct.
- (4) When a "SDCALL_RESP" message indicating "Receive Success" shown in Table 5.2-15 that includes a "INFO4" message shown in Table 5.1-2(the instructed Destination is the Interoperability Tester 1) in SCCH has been transmitted from the Interoperability Tester 2, verify that TR transmits a "SDCALL_RESP" message indicating "Receive Success" shown in Table 5.2-15 that includes any of "INFO4" messages shown in **Table 5.2-8 to Table 5.2-10** (the instructed Destination is the Interoperability Tester 1) in SCCH.
- (5) Verify that the "SDCALL_RESP" message which has been relayed by the TR and then received by the Interoperability Tester 1 is correct.
- (6) When a "TX_REL"(Inbound) message shown in Table 5.2-15 that includes an "INFO4(EOT)" message shown in Table 5.1-2 in SCCH has been transmitted from the Interoperability Tester 1, verify that TR transmits a "TX_REL"(Outbound) message shown in Table 5.2-15 that includes "INFO4(EOT)" message shown in Table 5.1-2 in SCCH.

Table 5.2-22 SDCALL_REQ(Header) message

	Single Trunked System	Multi Trunked System
CC Option	00(Individual Call, Group Call, All Call)	10(Individual Call, Group Call, All Call)
Call Type	100b (Individual Call) 001b (Conference Group Call / All Call)	
Source	Home Repeater Value of Home Repeater number Unit ID of Interoperability Tester 1	Source Prefix Prefix of Interoperability Tester 1
Destination	Home Repeater Value of Home Repeater number Unit ID of Interoperability Tester 2 (Individual Call) Group ID (Group Call)	Destination Prefix Value of Destination Prefix
Cipher Type	00b	
Key ID	000000b	
Packet Information	Except for the following, depends on the format to be used for testing. Delivery Flag = 0 (Group Call, Individual Call) Unconfirmed Delivery Flag = 1 (Individual Call) Confirmed	

Table 5.2-23 SDCALL_RESP message

	Single Trunked System	Multi Trunked System
CC Option	00(Individual Call, Group Call, All Call)	10(Individual Call, Group Call, All Call)
Call Type	100b(Individual Call)	
Source	Home Repeater Value of Home Repeater number Unit ID of Interoperability Tester 2	Source Prefix Prefix of Interoperability Tester 2
Destination	Home Repeater Value of Home Repeater number Unit ID of Interoperability Tester 1	Destination Prefix Prefix of Interoperability Tester 1
Cause (SS)	01 (Receive Success)	
Error Block Flag	0000	

5.2.7. Data Call Tests

This test shall verify that contents of messages used for Data Call are correct, and that the unit under test correctly responds to these messages.

This test includes the test methods for the following two modes:

- (1) Broadcast Data Call
- (2) Unit to Unit Data Call

Figure 5.2-1 shows the configuration diagram for testing.

The following 12 types of messages shall be applied.

Table 5.2-7 : ISM INFO4 / INFO2 message

Table 5.2-8 : OSM INFO4 / INFO2 (Busy Repeater Message) message

Table 5.2-9 : OSM INFO4 / INFO2 (Free Repeater Message) message

Table 5.2-10 : OSM INFO4 / INFO2 (Site ID Message Message) message

Table 5.2-11 : ISM / OSM INFO4 (EOT) message

Table 5.2-12 : CALL_REQ message from Interoperability Tester

Table 5.2-13 : CALL_CONN_RESP message from TR

Table 5.2-14 : CALL_RESP message from TR

Table 5.2-15 : TX_REL(Inbound) message from Interoperability Tester

Table 5.2-16 : TX_REL(Outbound) message from TR

Table 5.2-24 : DCALL (Header) message

Table 5.2-25 : DCALL_ACK message

It is recommended that DCALL (User Data) messages are constructed using User Data having a data length that is divided into multiple packets.

No contents of User Data are specified in this document.

5.2.7.1. Broadcast Data Call Test

In this test, parameters for messages to be used shall apply the values for Group Call.

5.2.7.1.1. Group Call Success

- (1) Link connection will be shown in Section 5.2.2.
- (2) When a "DCALL"(Header) message shown in Table 5.2-15 that includes a "INFO4" message shown in Table 5.1-2 and "DCALL"(User Data) message have been transmitted from the Interoperability Tester 1, verify that TR relays and transmits the same "DCALL"(Header)" and "DCALL"(User Data) messages. Provided however that be sure to SCCH has been replaced with INFO4 message shown in Table 5.2-8 to Table 5.2-10. The procedural steps to follow in substitution of INFO4 will not be described.
- (3) When a "TX_REL" (Inbound) message shown in Table 5.2-15 that includes a "INFO4" (EOT) message shown in Table 5.1-2 in SCCH message has been transmitted from the Interoperability Tester 1, verify that TR transmits a "TX_REL"(Outbound) message shown in Table 5.2-16 that includes a "INFO4" (EOT) message shown in Table 5.1-2 in SCCH.
- (4) Verify that the data which has been relayed by the TR and then received by the Interoperability Tester 2 is correct.

5.2.7.2. Unit to Unit Data Call Test

In this test, parameters for messages to be used shall apply the value for Individual Call.

5.2.7.2.1. Individual Call Success

- (1) Link connection will be shown in Section 5.2.2.
- (2) When a "DCALL"(Header) message shown in Table 5.2-15 that includes a "INFO4" message shown in Table 5.1-2 and "DCALL"(User Data) message have

been transmitted from the Interoperability Tester 1, verify that TR relays and transmits the same "DCALL"(Header)" and "DCALL"(User Data) messages. Provided however that be sure to SCCH has been replaced with INFO4 message shown in Table 5.2-8 to Table 5.2-10. The procedural steps to follow in substitution of INFO4 will not be described.

- (3) Verify that the data which has been relayed by the TR and then received by the Interoperability Tester 2 is correct.
- (4) When a " DCALL_ACK" message indicating "Receive Success" shown in Table 5.2-15 that includes a "INFO4" message shown in Table 5.1-2(the instructed Destination is the Interoperability Tester 1) in SCCH has been transmitted from the Interoperability Tester 2, verify that TR relays and transmits a " DCALL_ACK" message indicating "Receive Success" shown in Table 5.2-15 that includes any of "INFO4" messages shown in **Table 5.2-8** to **Table 5.2-10** (the instructed Destination is the Interoperability Tester 1) in SCCH.
- (5) Verify that the "DCALL_ACK" message which has been relayed by the TR and then received by the Interoperability Tester 1 is correct.
- (6) When a "TX_REL"(Inbound) message shown in Table 5.2-15 that includes an "INFO4(EOT)" message shown in Table 5.1-2 in SCCH has been transmitted from the Interoperability Tester 1, verify that TR transmits a "TX_REL"(Outbound) message shown in Table 5.2-15 that includes "INFO4(EOT)" message shown in Table 5.1-2 in SCCH.

Table 5.2-24 DCALL(Header) message

	Single Trunked System	Multi Trunked System
CC Option	00(Individual Call, Group Call, All Call)	10(Individual Call, Group Call, All Call)
Call Type	100b (Individual Call) 001b (Conference Group Call / All Call)	
Source	Home Repeater Value of Home Repeater number Unit ID of Interoperability Tester 1	Source Prefix Prefix of Interoperability Tester 1
Destination	Home Repeater Value of Home Repeater number Unit ID of SU Interoperability Tester No.2 Group ID (Group Call)	Destination Prefix Value of Destination Prefix
Cipher Type	00b	
Key ID	000000b	
Packet Information	Except for the following, depends on the format to be used for testing. Delivery Flag = 0 Unconfirmed (Group Call, Individual Call) Delivery Flag = 1 Confirmed (Individual Call)	

Table 5.2-25 DCALL_ACK message

	Single Trunked System	Multi Trunked System
CC Option	00(Individual Call, Group Call, All Call)	
Call Type	100b(Individual Call)	
Source	Home Repeater Value of Home Repeater number Unit ID of Interoperability Tester 2	Source Prefix Prefix of Interoperability Tester 2
Destination	Home Repeater Value of Home Repeater number Unit ID of SU Interoperability Tester 1	Destination Prefix Prefix of Interoperability Tester 1
Response Information	00 001b (Receive Success)	
Error Block Flag	0000	

5.2.8. Status Call Tests

This test shall verify that contents of messages used for Status Call are correct, and that the unit under test correctly responds to these messages.

This test includes the test methods for the following two modes.

- (1) Broadcast Status Call
- (2) Status Call

Figure 5.2-2 shows the configuration diagram for testing.

The following 12 types of messages shall be applied.

Table 5.2-7 : ISM INFO4 / INFO2 message

Table 5.2-8 : OSM INFO4 / INFO2 (Busy Repeater Message) message

Table 5.2-9 : OSM INFO4 / INFO2 (Free Repeater Message) message

Table 5.2-10 : OSM INFO4 / INFO2 (Site ID Message Message) message

Table 5.2-11 : ISM / OSM INFO4 (EOT) message

Table 5.2-12 : CALL_REQ message from Interoperability Tester

Table 5.2-13 : CALL_CONN_RESP message from TR

Table 5.2-14 : CALL_RESP message from TR

Table 5.2-15 : TX_REL(Inbound) message from Interoperability Tester

Table 5.2-16 : TX_REL(Outbound) message from TR

Table 5.2-26 : STAT_REQ message

Table 5.2-27 : STAT_RESP message

5.2.8.1. Broadcast Status Call Test

In this test, parameters for messages to be used shall apply the values for Group Call.

5.2.8.1.1. Status Success

- (1) Link connection will be shown in Section 5.2.2.
- (2) When STAT_REQ message shown in Table 5.2-26 that includes "INFO4" message shown in Table 5.2-7 in SCCH has been transmitted from the Interoperability Tester 1, verify that TR relays the message, and transmits a STAT_REQ message shown in Table 5.2-26 that includes any of "INFO4" messages shown in Table 5.2-8 to Table 5.2-10 in SCCH.
- (3) When a "TX_REL" (Inbound) message shown in Table 5.2-15 that includes a "INFO4" (EOT) message shown in Table 5.2-11 in SCCH message has been transmitted from the Interoperability Tester 1, verify that TR transmits a "TX_REL"(Outbound) message shown in Table 5.2-16 that includes a "INFO4" (EOT) message shown in Table 5.2-11 in SCCH.
- (4) Verify that the Status data which has been relayed by the TR and then received by the Interoperability Tester 2 is correct.

5.2.8.2. Individual Status Call Test

In this test, parameters for messages to be used shall apply the values for Individual Call.

The procedure for Status Call is different between Confirmed format and Unconfirmed format.

To verify the interoperability, a unit under test shall pass the test item for at least either of the Confirmed format or the Unconfirmed format.

5.2.8.2.1. Status Success - (Confirmed)

- (1) Link connection will be shown in Section 5.2.2.
- (2) When STAT_REQ message shown in Table 5.2-26 that includes "INFO4" message shown in Table 5.2-7 in SCCH has been transmitted from the Interoperability Tester 1, verify that TR relays the message, and transmits a STAT_REQ message shown in Table 5.2-26 that includes any of "INFO4" messages shown in Table 5.2-8 to Table 5.2-10 in SCCH.
- (3) Verify that the status data which has been relayed by the TR and then received by the Interoperability Tester 2 is correct.
- (4) When a STAT_RESP message indicating "Receive Success" shown in Table 5.2-15 that includes a "INFO4" message shown in Table 5.1-2 (the instructed Destination is the Interoperability Tester 1) in SCCH has been transmitted from the Interoperability Tester 2, verify that TR relays and transmits a STAT_RESP message shown in Table 5.2-15 that includes any of "INFO4" messages shown in Table 5.2-8 to Table 5.2-10 (the instructed Destination is the Interoperability Tester 1) in SCCH.
- (5) Verify that the "STAT_RESP" message which has been relayed by the TR and then received by the Interoperability Tester 1 is correct.
- (6) When a "TX_REL"(Inbound) message shown in Table 5.2-15 that includes an "INFO4(EOT)" message shown in Table 5.1-2 in SCCH has been transmitted from the Interoperability Tester 1, verify that TR transmits a "TX_REL"(Outbound) message shown in Table 5.2-15 that includes "INFO4(EOT)" message shown in Table 5.1-2 in SCCH.

5.2.8.2.2. Status Success - (Unconfirmed)

- (1) Link connection will be shown in Section 5.2.2.
- (2) When STAT_REQ message shown in Table 5.2-26 that includes "INFO4" message shown in Table 5.2-7 in SCCH has been transmitted from the Interoperability Tester 1, verify that TR relays the message, and transmits a STAT_REQ message shown in Table 5.2-26 that includes any of "INFO4" messages shown in Table 5.2-8 to Table 5.2-10 in SCCH.
- (3) When a "TX_REL" (Inbound) message shown in Table 5.2-15 that includes a "INFO4" (EOT) message shown in Table 5.2-11 in SCCH message has been transmitted from the Interoperability Tester 1, verify that TR transmits a "TX_REL"(Outbound) message shown in Table 5.2-16 that includes a "INFO4" (EOT) message shown in Table 5.2-11 in SCCH.
- (4) Verify that the status data which has been relayed by the TR and then received by the Interoperability Tester 2 is correct.

Table 5.2-26 STAT_REQ message

	Single Trunked System	Multi Trunked System
CC Option	00 (Individual Call, Group Call, All Call)	10 (Individual Call, Group Call, All Call)
Call Type	100b (Individual Call) 001b (Conference Group Call / All Call)	
Status Call Option	00000b (Unconfirmed) 01000b (Confirmed)	
Source	Home Repeater Value of Home Repeater number	Source Prefix Prefix of Interoperability Tester 1
	Unit ID of Interoperability Tester 1	
Destination	Home Repeater Value of Home Repeater number	Destination Prefix Value of Destination Prefix
	Unit ID of Interoperability Tester 2 (Individual Call) Group ID (Group Call)	
Status	01~CF (User definable)	

Table 5.2-27 STAT_RESP message

	Single Trunked System	Multi Trunked System
CC Option	00 (Individual Call, Group Call, All Call)	10 (Individual Call, Group Call, All Call)
Call Type	100b (Individual Call)	
Source	Home Repeater Value of Home Repeater number	Source Prefix Prefix of Interoperability Tester 2
	Unit ID of Interoperability Tester 2	
Destination	Home Repeater Value of Home Repeater number	Destination Prefix Prefix of Interoperability Tester 1
	Unit ID of Interoperability Tester 1	
Cause(SS)	01 (Receive Success)	

5.2.9. Status Inquiry Test

This test shall verify that contents of messages used for Status Inquiry processing are correct, and that the unit under test correctly responds to these messages.

Figure 5.2-2 shows the configuration diagram for testing.

The following 12 types of messages shall be applied.

- Table 5.2-7 : ISM INFO4 / INFO2 message
- Table 5.2-8 : OSM INFO4 / INFO2 (Busy Repeater Message) message
- Table 5.2-9 : OSM INFO4 / INFO2 (Free Repeater Message) message
- Table 5.2-10 : OSM INFO4 / INFO2 (Site ID Message Message) message
- Table 5.2-11 : ISM / OSM INFO4 (EOT) message
- Table 5.2-12 : CALL_REQ message from Interoperability Tester
- Table 5.2-13 : CALL_CONN_RESP message from TR
- Table 5.2-14 : CALL_RESP message from TR
- Table 5.2-15 : TX_REL(Inbound) message from Interoperability Tester
- Table 5.2-16 : TX_REL(Outbound) message from TR
- Table 5.2-28 : STAT_INQ_REQ message
- Table 5.2-29 : STAT_INQ_RESP message

5.2.9.1. Status Inquiry Success

- (1) Link connection will be shown in Section 5.2.2.
- (2) When STAT_INQ_REQ message shown in Table 5.2-26 that includes "INFO4" message shown in Table 5.2-7 in SCCH has been transmitted from the Interoperability Tester 1, verify that TR relays the message, and transmits a STAT_INQ_REQ message shown in Table 5.2-26 that includes any of "INFO4" messages shown in Table 5.2-8 to Table 5.2-10 in SCCH.
- (3) Verify that the status inquiry data which has been relayed by the TR and then received by the Interoperability Tester 2 is correct.
- (4) When a STAT_INQ_RESP message indicating "Receive Success" shown in Table 5.2-15 that includes a "INFO4" message shown in Table 5.1-2(the instructed Destination is the Interoperability Tester 1) in SCCH has been transmitted from the Interoperability Tester 2, verify that TR relays and transmits a STAT_INQ_RESP message shown in Table 5.2-15 that includes any of "INFO4" messages shown in **Table 5.2-8** to **Table 5.2-10** (the instructed Destination is the Interoperability Tester 1) in SCCH.
- (5) Verify that the "STAT_INQ_RESP" message which has been relayed by the TR and then received by the Interoperability Tester 1 is correct.
- (6) When a "TX_REL"(Inbound) message shown in Table 5.2-15 that includes an "INFO4(EOT)" message shown in Table 5.1-2 in SCCH has been transmitted from the Interoperability Tester 1, verify that TR transmits a "TX_REL"(Outbound) message shown in Table 5.2-15 that includes "INFO4(EOT)" message shown in Table 5.1-2 in SCCH.

Table 5.2-28 STAT_INQ_REQ message

	Single Trunked System	Multi Trunked System
CC Option	00(Individual Call, Group Call, All Call)	10(Individual Call, Group Call, All Call)
Call Type	100b (Individual Call)	
Status Call Option	01000b (Confirmed)	
Source	Home Repeater Value of Home Repeater number	Source Prefix Prefix of Interoperability Tester 1
	Unit ID of Interoperability Tester 1	
Destination	Home Repeater Value of Home Repeater number	Destination Prefix Prefix of Interoperability Tester 2
	Unit ID of Interoperability Tester 2	

Table 5.2-29 STAT_INQ_RESP message

	Single Trunked System	Multi Trunked System
CC Option	00(Individual Call, Group Call, All Call)	10(Individual Call, Group Call, All Call)
Call Type	100b(Individual Call)	
Source	Home Repeater Value of Home Repeater number	Source Prefix Prefix of Interoperability Tester 2
	Unit ID of Interoperability Tester 2	
Destination	Home Repeater Value of Home Repeater number	Destination Prefix Prefix of Interoperability Tester 1
	Unit ID of Interoperability Tester 1	
Cause(SS)	01 (Receive Success)	
Status	01~CF (User definable)	

5.2.10. Remote Control Test

This test shall verify that contents of messages used for Remote Control are correct, and that the unit under test correctly responds to these messages.

Table 5.2-2 shows the configuration diagram for testing.

The following 10 types of messages shall be applied.

- Table 5.2-7 : ISM INFO4 / INFO2 message
- Table 5.2-8 : OSM INFO4 / INFO2 (Busy Repeater Message) message
- Table 5.2-9 : OSM INFO4 / INFO2 (Free Repeater Message) message
- Table 5.2-10 : OSM INFO4 / INFO2 (Site ID Message Message) message
- Table 5.2-11 : ISM / OSM INFO4 (EOT) message
- Table 5.2-12 : CALL_REQ message from Interoperability Tester
- Table 5.2-13 : CALL_CONN_RESP message from TR
- Table 5.2-14 : CALL_RESP message from TR
- Table 5.2-30 : REM_CON_REQ message
- Table 5.2-31 : REM_CON_RESP message

5.2.10.1. Remote Control Success

- (1) Link connection will be shown in Section 5.2.2.
- (2) When REM_CON_REQ message shown in Table 5.2-26 that includes "INFO4" message shown in Table 5.2-7 in SCCH has been transmitted from the Interoperability Tester 1, verify that TR relays the message, and transmits a REM_CON_REQ message shown in Table 5.2-26 that includes any of "INFO4" messages shown in Table 5.2-8 to Table 5.2-10 in SCCH.
- (3) Verify that the remote control data which has been relayed by the TR and then received by the Interoperability Tester 2 is correct.
- (4) When a REM_CON_RESP message indicating "Receive Success" shown in Table 5.2-15 that includes a "INFO4" message shown in Table 5.1-2(the instructed Destination is the Interoperability Tester 1) in SCCH has been transmitted from the Interoperability Tester 2, verify that TR relays and transmits a REM_CON_RESP message shown in Table 5.2-15 that includes any of "INFO4" messages shown in **Table 5.2-8** to **Table 5.2-10** (the instructed Destination is the Interoperability Tester 1) in SCCH.
- (5) Verify that the "REM_CON_RESP" message which has been relayed by the TR and then received by the Interoperability Tester 1 is correct.

Table 5.2-30 REM_CON_REQ message

	Single Trunked System	Multi Trunked System
CC Option	00 (Individual Call, Group Call, All Call)	10 (Individual Call, Group Call, All Call)
G/U	1b (UNIT ID)	
Delivery	1b (Confirmed)	
Control Command	Depending on the test configuration	
Source	Home Repeater Value of Home Repeater number	Source Prefix Prefix of Interoperability Tester 1
	Unit ID of Interoperability Tester 1	
Destination	Home Repeater Value of Home Repeater number	Destination Prefix Prefix of Interoperability Tester 2
	Unit ID of Interoperability Tester 2	
Control Parameter	Depending on the test configuration	

Table 5.2-31 REM_CON_RESP message

	Single Trunked System	Multi Trunked System
CC Option	00 (Individual Call, Group Call, All Call)	10 (Individual Call, Group Call, All Call)
G/U	1b (UNIT ID)	
Control Command	Depending on the test configuration	
Source	Home Repeater Value of Home Repeater number	Source Prefix Prefix of Interoperability Tester 2
	Unit ID of Interoperability Tester 2	
Destination	Home Repeater Value of Home Repeater number	Destination Prefix Prefix of Interoperability Tester 1
	Unit ID of Interoperability Tester 1	
Cause(SS)	01 (Receive Success)	

5.2.11. Emergency Test

This test shall verify that contents of messages used during the Emergency state are correct, and that the unit under test correctly responds to these messages.

This test is designed to evaluate the following 2 varieties of Emergency status.

In order to carry out an interconnection, each instrument to be tested is required to show satisfactory results in the items to be confirmed on at least one of mode tests (1) and (2).

- (1) Emergency Call
- (2) Emergency Alert

Figure 5.2-2 shows the configuration diagram for testing.

5.2.11.1. Emergency Call

This test shall verify that contents of messages used for an Emergency Group Voice Call are correct, and that the unit under test correctly responds to these messages.

This test includes the following 2 varieties of tests to evaluate the mode of operation. In order to carry out an interconnection, each instrument to be tested is required to show satisfactory results in the items to be confirmed on at least one of mode tests (1) and (2).

- (1) Group Voice Call
- (2) Individual Voice Call

The test method of (1) and (2) are the same as shown in Section 5.2.3 and Section 5.2.4, respectively. Provided however that be sure to apply 80(Single Trunked) or 90(Multi Trunked) as a value of CC Option for each message.

5.2.11.2. Emergency Alert

In this test, we evaluate the validity of the description of message used in the case in which a SU provides notification of the occurrence of "Emergency" status, and verify whether or not the SU operates as intended in response to those messages.

This test includes the following 2 varieties of tests to evaluate the mode of operation.

In order to carry out an interconnection, each instrument to be tested is required to show satisfactory results in the items to be confirmed on at least one of mode tests (1) and (2).

- (1) Broadcast Status Call
- (2) Status Call

The test method of (1) and (2) are the same as shown in Section 5.2.8.1 and Section 5.2.8.2, respectively.

In this test, a status representing "Emergency" will be used.

5.2.12. Transmission Trunking Test

This test shall verify the TR behaviors while in Transmission Trunking Mode.

Trunking Mode of a TR and interoperability tester shall be configured as Transmission Trunking Mode. A configuration method for Trunking Mode shall be appropriately determined by the respective manufacturer.

Figure 5.2-2 shows the configuration diagram for testing. This test is done using Conference Group Voice Call or Individual Voice Call.

The description about the procedure on an RTCH2 is omitted for this test.

Transmission Trunking means an RTCH2 assignment process takes place each time when an SU transmits.

Trunking Mode is affected by the specifications of the manufacturer which manufactures a TR; hence, it is necessary to perform at least one of the following test items.

- (1) Verify that a TR immediately sends a TX_REL/EOT message on an RTCH2 upon receipt of the TX_REL/EOT message from an interoperability tester.
- (2) Or, it may be verified that a TR conforms to Transmission Trunking behavior specified by the TR manufacturer.

5.2.13. Message Trunking Test

This test shall verify the TR behaviors while in Message Trunking Mode.

Trunking Mode of a TR and interoperability tester shall be configured as Message Trunking Mode. A configuration method for Trunking Mode shall be appropriately determined by the respective manufacturer.

Figure 5.2-2 shows the configuration diagram for testing. This test is done using Individual Voice Call.

The description about the procedure on an RTCH2 is omitted for this test.

Message Trunking means a behavior that an SU can repeatedly transmit on the same RTCH2 during a period of Hold Time.

Trunking Mode is affected by the specifications of the manufacturer which manufactures a TR; hence, it is necessary to perform at least one of the following test items.

- (1) Verify that a TR continues to transmit on an RTCH2 until a Hold Time elapses and sends a TX_REL message, after receiving of a TX_REL message from an interoperability tester.
- (2) Or, it may be verified that a TR conforms to Message Trunking behavior specified by the TR manufacturer.

5.2.14. Encryption Test

This test shall verify that a TR correctly receives and repeats an encrypted voice call. Figure 5.2-2 shows the configuration diagram for testing.

This test shall verify under the following conditions that Interoperability tester No. 1 sends an encrypted voice call, a TR repeats the signal, and then Interoperability tester No. 2 correctly outputs the received audio signal.

This test shall be done after completion of channel assignment on an RTCH2, and the testing procedure on an RTCH2 is omitted in this document.

No mode to be used for testing shall be specified.

Handshake sequence operation at link connection to TR is omitted.

SCCH(INFO1) in the superframe included voice call data transmitted from the Interoperability tester is shown in Table 5.2-18, but apply Cipher Type and Key ID appropriately which match each parameter to be used in the encryption data.

- (1) In the test for Scramble Encryption, verify that when Interoperability tester No. 1 sends an encrypted voice call using a VCALL message as described in Table 5.2-32, Interoperability tester No. 2 correctly outputs the received audio signal.

Table 5.2-32 VCALL message (Encryption)

	Single Trunked System	Multi Trunked System
CC Option	00 (Individual Call, Group Call, All Call)	10 (Individual Call, Group Call, All Call)
Call Type	100b (Individual Call) 001b (Conference Group Call, All Call) 000b (Broadcast Call)	
Source	Home Repeater Value of Home Repeater number	Source Prefix Prefix of Interoperability Tester 1
	Unit ID of Interoperability Tester 1	
Destination	Home Repeater Value of Home Repeater number	Destination Prefix Value of Destination Prefix
	Group ID (Group Call) Unit ID of Interoperability Tester 2 (Individual Call)	
Cipher Type	01b	
Key ID	000001b~111111b	

5.2.15. Registration Test

This test shall verify that contents of messages used for the Registration process are correct, and that the unit under test correctly responds to these messages. (Multi Trunked System)

Figure 5.2-1 shows the configuration diagram for testing. The following 11 types of messages shall be applied.

- Table 5.2-33 : ISM INFO4 message
- Table 5.2-34 : OSM INFO4 (Busy Repeater Message) message
- Table 5.2-35 : OSM INFO4 (Free Repeater Message) message
- Table 5.2-36 : OSM INFO4 / INFO2 (Site ID Message Message) message
- Table 5.2-37 : ISM / OSM INFO4 (EOT) message
- Table 5.2-38 : CALL_REQ message from Interoperability Tester
- Table 5.2-39 : CALL_RESP message from TR
- Table 5.2-40 : REG_REQ message from Interoperability Tester
- Table 5.2-41 : REG_RESP message from TR
- Table 5.2-42 : TX_REL(Inbound) message from Interoperability Tester
- Table 5.2-43 : TX_REL(Outbound) message from TR

5.2.15.1. Registration Accept

- (1) When the Interoperability Tester has transmitted a "CALL_REQ" message shown in Table 5.2-15 that includes a "INFO4" message shown in Table 5.1-2 in SCCH, verify that TR transmits a "CALL_RESP" message shown in Table 5.2-15 that includes any of "INFO4" messages shown in Table 5.2-34 to Table 5.2-36 in SCCH.
- (2) When the Interoperability Tester has transmitted a "REG_REQ" message shown in Table 5.2-15 that includes a "INFO4" message shown in Table 5.1-2 in SCCH, verify that TR transmits a "REG_RESP" message indicating "Accept" shown in Table 5.2-15 that includes any of "INFO4" messages shown in Table 5.2-34 to Table 5.2-36 in SCCH.
- (3) When the Interoperability Tester has transmitted a "TX_REL" (Inbound) message shown in Table 5.2-15 that includes a "INFO4" (EOT) message shown in Table 5.1-2 in SCCH, verify that TR transmits a "TX_REL" (Outbound) message shown in Table 5.2-15 that includes a "INFO4" (EOT) message shown in Table 5.1-2 in SCCH.

Table 5.2-33 ISM INFO4 message

Structure	00b
Area	Value of Area
Repeater in Use	Value of Collect Repeater number
Destination Prefix	00000b
Destination Unit ID	7FB
G/U	0b

Table 5.2-34 OSM INFO4 (Busy Repeater Message) message

Structure	00b
Area	Value of Area
Go to Repeater	Value of Collect Repeater number
Destination Prefix	00000b
Destination Unit ID	7FB
G/U	0b

Table 5.2-35 OSM INFO4 (Free Repeater Message) message

Structure	00b
Area	Value of Area
Free Repeater1	Value of Free Repeater number
Free Repeater1	Value of Free Repeater number
ID	7FC

Table 5.2-36 OSM INFO4 / INFO2 (Site ID Message) message

Structure	00b (INFO4)
Area	Value of Area
Site Type	Value of Site Type
Site Code	Value of Site Code
ID	7F9

Table 5.2-37 ISM / OSM INFO4 (EOT) message

Structure	00b (INFO4)
Area	Value of Area
Repeater in Use / Go to Repeater	1111b
Destination Prefix	00000b
Destination ID	7FB
G/U	0b

Table 5.2-38 CALL_REQ message

CC Option	10
Call Type	011b (Session Call)
Source Prefix	Prefix of Interoperability Tester
Source Unit ID	Unit ID of Interoperability Tester
Destination Prefix	00000b
Destination Unit ID	7FB
System ID Option	10000b / 01000b
System ID	Value of System ID

Table 5.2-39 CALL_RESP message

CC Option	10
Call Type	011b (Session Call)
Free Repeater	Any value in the range of 00001b-11110b
Source Prefix	Prefix of Interoperability Tester
Source Unit ID	Unit ID of Interoperability Tester
Destination Prefix	00000b
Destination Unit ID	7FB
System ID Option	10000b / 01000b
System ID	Value of System ID

Table 5.2-40 REG_REQ message

Registration Option	00000b
(Subscriber Home) System ID	Any System ID
Source Prefix	Prefix of Interoperability Tester
Source Unit ID	Unit ID of Interoperability Tester
Group Prefix	Selected Group Prefix Number of Interoperability Tester
Group ID	Selected Group ID OF Interoperability Tester
Subscriber Type	0000
Version Number	Any
Registration Sequence Number	Any

Table 5.2-41 REG_RESP message

Registration Option	00000b
(Subscriber Home) System ID	Any System ID
Destination Prefix	Prefix Number of Interoperability Tester
Destination Unit ID	Unit ID of Interoperability Tester
Group Prefix	Selected Group Prefix Number of Interoperability Tester
Group ID	Selected Group ID of Interoperability Tester
Cause(MM)	01(Accept)

Table 5.2-42 TX_REL (Inbound) message

CC Option	10
Call Type	011b (Session Call)
Source Prefix	Prefix of Interoperability Tester
Source Unit ID	Unit ID of Interoperability Tester
Destination Prefix	00000b
Destination Unit ID	7FB

Table 5.2-43 TX_REL (Outbound) message

CC Option	10
Call Type	011b (Session Call)
Free Repeater	Any value in the range of 00001b-11110b
Source Prefix	Prefix of Interoperability Tester
Source Unit ID	Unit ID of Interoperability Tester
Destination Prefix	00000b
Destination Unit ID	7FB

5.2.16. Registration Command Test

In this test, we evaluate the validity of the description of a message used in the case in which TR instructs a SU to execute registration process, and verify whether or not the SU operates as intended in response to those messages. (Multi Trunked System only)

The connection configuration of this test is shown in Figure 5.1-4. The following only one kind of message will be used.

Table 5.1-41 : OSM INFO4(REG_COM) message

- (1) When TR transmits to SU a "REG_COM" message that instructs SU to execute Registration Process, the TC also sends "REG_COM" message shown in Table 5.1-41.

5.2.17. Registration Clear Test

This test shall verify that contents of messages used for clearing the Registration information are correct, and that the unit under test correctly responds to these messages. (Multi Trunked System)

Figure 5.2-1 shows the configuration diagram for testing. The following 11 types of messages shall be applied.

Table 5.2-33 : ISM INFO4 message

Table 5.2-34 : OSM INFO4 (Busy Repeater Message) message

Table 5.2-35 : OSM INFO4 (Free Repeater Message) message

Table 5.2-36 : OSM INFO4 / INFO2 (Site ID Message Message) message

Table 5.2-37 : ISM / OSM INFO4 (EOT) message

Table 5.2-38 : CALL_REQ message from Interoperability

Table 5.2-39 : CALL_RESP message from TR

Table 5.2-42 : TX_REL(Inbound) message from Interoperability Tester

Table 5.2-43 : TX_REL(Outbound) message from TR

Table 5.2-44 : REG_C_REQ message from Interoperability Tester 1

Table 5.2-45 : REG_C_RESP message from TR

5.2.17.1. Registration Clear Accept

- (1) When the Interoperability Tester has transmitted a "CALL_REQ" message shown in Table 5.2-15 that includes a "INFO4" message shown in Table 5.1-2 in SCCH, verify that TR transmits a "CALL_RESP" message shown in Table 5.2-15 that includes any of "INFO4" messages shown in Table 5.2-34 to Table 5.2-36 in SCCH.
- (2) When the Interoperability Tester has transmitted a "REG_C_REQ" message shown in Table 5.2-15 that includes a "INFO4" message shown in Table 5.1-2 in SCCH, verify that TR transmits a "REG_C_RESP" message indicating "Accept" shown in Table 5.2-15 that includes any of "INFO4" messages shown in Table 5.2-34 to Table 5.2-36 in SCCH.
- (3) When the Interoperability Tester has transmitted a "TX_REL" (Inbound) message shown in Table 5.2-15 that includes a "INFO4" (EOT) message shown in Table 5.1-2 in SCCH, verify that TR transmits a "TX_REL" (Outbound) message shown in Table 5.2-15 that includes a "INFO4" (EOT) message shown in Table 5.1-2 in SCCH.

Table 5.2-44 REG_C_REQ message

Registration Option	00000b
(Subscriber Home) System ID	Any System ID
Source Prefix	Prefix Number of Interoperability Tester 1
Source Unit ID	Unit ID of Interoperability Tester 1

Table 5.2-45 REG_C_RESP message

Registration Option	00000b
(Subscriber Home) System ID	Any System ID
Destination Prefix	Prefix Number of Interoperability Tester 1
Destination Unit ID	Unit ID of Interoperability Tester 1
Cause(MM)	01(Accept)

5.2.18. Group Registration Test

This test shall verify that contents of messages used for the Group Registration are correct, and that the unit under test correctly responds to these messages. (Multi Trunked System only)

Figure 5.2-1 shows the configuration diagram for testing. The following 11 types of messages shall be applied.

- Table 5.2-33 : ISM INFO4 message
- Table 5.2-34 : OSM INFO4 (Busy Repeater Message) message
- Table 5.2-35 : OSM INFO4 (Free Repeater Message) message
- Table 5.2-36 : OSM INFO4 / INFO2 (Site ID Message Message) message
- Table 5.2-37 : ISM / OSM INFO4 (EOT) message
- Table 5.2-38 : CALL_REQ message from Interoperability Test
- Table 5.2-39 : CALL_RESP message from TR
- Table 5.2-42 : TX_REL(Inbound) message from Interoperability Test
- Table 5.2-43 : TX_REL(Outbound) message from TR
- Table 5.2-46 : GRP_REG_REQ message from Interoperability Test
- Table 5.2-47 : GRP_REG_RESP message from TR

5.2.18.1. Group Registration Accept

- (1) When the Interoperability Tester has transmitted a "CALL_REQ" message shown in Table 5.2-15 that includes a "INFO4" message shown in Table 5.1-2 in SCCH, verify that TR transmits a "CALL_RESP" message shown in Table 5.2-15 that includes any of "INFO4" messages shown in Table 5.2-34 to Table 5.2-36 in SCCH.
- (2) When the Interoperability Tester has transmitted a "GRP_REG_REQ" message shown in Table 5.2-15 that includes a "INFO4" message shown in Table 5.1-2 in SCCH, verify that TR transmits a "GRP_REG_RESP" message indicating "Accept" shown in Table 5.2-15 that includes any of "INFO4" messages shown in Table 5.2-34 to Table 5.2-36 in SCCH.
- (3) When the Interoperability Tester has transmitted a "TX_REL" (Inbound) message shown in Table 5.2-15 that includes a "INFO4" (EOT) message shown in Table 5.1-2 in SCCH, verify that TR transmits a "TX_REL" (Outbound) message shown in Table 5.2-15 that includes a "INFO4" (EOT) message shown in Table 5.1-2 in SCCH..

Table 5.2-46 GRP_REG_REQ message

Group Registration Option	00
Source Prefix	Prefix Number of Interoperability Tester 1
Source Unit ID	Unit ID of Interoperability Tester 1
Group Prefix	Selected Group Prefix Number of Interoperability Tester 1
Group ID	Selected Group ID of Interoperability Tester 1

Table 5.2-47 GRP_REG_RESP message

Group Registration Option	00
Source Prefix	Prefix Number of Interoperability Tester 1
Source Unit ID	Unit ID of Interoperability Tester 1
Group Prefix	Selected Group Prefix Number of Interoperability Tester 1
Group ID	Selected Group ID of Interoperability Tester 1
Cause(MM)	01(Accept)

5.2.19. Authentication Tests

This test shall verify that contents of messages used for the Authentication process are correct, and that the unit under test correctly responds to these messages. (Multi Trunked System only)

This test includes the test methods for the following two Authentication processes:

- (1) Authentication during Registration Process
- (2) Authentication Inquiry by trunking Repeater

Procedure (1) represents a case that a TR sends a request for Authentication while an SU is doing the Registration process, and Procedure (2) represents a case that a TR sends a request for Authentication to an SU which has completed the Registration process.

Figure 5.2-1 shows the configuration diagram for testing. The following 13 types of messages shall be applied.

- Table 5.2-33 : ISM INFO4 message
- Table 5.2-34 : OSM INFO4 (Busy Repeater Message) message
- Table 5.2-35 : OSM INFO4 (Free Repeater Message) message
- Table 5.2-36 : OSM INFO4 / INFO2 (Site ID Message Message) message
- Table 5.2-37 : ISM / OSM INFO4 (EOT) message
- Table 5.2-38 : CALL_REQ message from Interoperability Test
- Table 5.2-39 : CALL_RESP message from TR
- Table 5.2-40 : REG_REQ message from Interoperability
- Table 5.2-41 : REG_RESP message from TR
- Table 5.2-42 : TX_REL(Inbound) message from Interoperability Tester
- Table 5.2-43 : TX_REL(Outbound) message from TR
- Table 5.2-48 : AUTH_INQ_REQ message from TR
- Table 5.2-49 : AUTH_INQ_RESP message from Interoperability Tester

5.2.19.1. Authentication during Registration Process

- (1) Carry out operation of (1) shown in Section 5.2.15.1.
- (2) When the Interoperability Tester has transmitted a "REG_REQ" message shown in Table 5.2-15 that includes a "INFO4" message shown in Table 5.1-2 in SCCH, verify that TR transmits a "AUTH_INQ_REQ" message shown in Table 5.2-15 that includes any of "INFO4" messages shown in Table 5.2-34 to Table 5.2-36 in SCCH.
- (3) When the Interoperability Tester has transmitted a "AUTH_INQ_RESP" message shown in Table 5.2-15 that includes a "INFO4" message shown in Table 5.1-2 in SCCH, verify that TR transmits a "REG_RESP" message indicating "Accept" shown in Table 5.2-15 that includes any of "INFO4" messages shown in Table 5.2-34 to Table 5.2-36 in SCCH.
- (4) When the Interoperability Tester has transmitted a "TX_REL" (Inbound) message shown in Table 5.2-15 that includes a "INFO4" (EOT) message shown in Table 5.1-2 in SCCH, verify that TR transmits a "TX_REL" (Outbound) message shown in Table 5.2-15 that includes a "INFO4" (EOT) message shown in Table 5.1-2 in SCCH.

5.2.19.2. Authentication Inquiry by Trunking Repeater

- (1) Verify that TR transmits an "AUTH_INQ_REQ" message shown in Table 5.2-48 that includes any of "INFO4" messages shown in Table 5.2-34 to Table 5.2-36 in SCCH.

Table 5.2-48 AUTH_INQ_REQ message

Authentication Option	00
Source Prefix	00000b
Source Unit ID	7FB as TC ID
Destination Prefix	Prefix of Interoperability Tester
Destination Unit ID	Unit ID of Interoperability Tester
Authentication Parameter	Any
System ID Option	10000b / 01000b
System ID	Value of System ID

Table 5.2-49 AUTH_INQ_RESP message

Authentication Option	00
Source Prefix	Prefix of SU
Source Unit ID	Unit ID of SU
Destination Prefix	00000b
Destination Unit ID	7FB as TC ID
Authentication Value	Depends on ESN and Authentication Parameter of the SU
System ID Option	10000b / 01000b
System ID	Value of System ID

5.2.20. System Data Write Tests

In this test, we evaluate the validity of the description of a message used in System Data Write process, and verify whether or not SU operates as intended in response to those messages. (Multi Trunked System only)

In this test, the following 2 varieties of procedural steps to follow in executing System Data Write process are included.

- (1) System Data Write during Registration Process
- (2) System Data Write by Trunking Repeater

(1) is the case in which system data communication will be carried out with a SU that has not completed the Registration Process. On the other hand, (2) is the case in which system data communication will be carried out with a SU that has already completed the Registration Process.

Figure 5.2-1 shows the configuration diagram for testing. The following 13 types of messages shall be applied.

Table 5.2-33 : ISM INFO4 message

Table 5.2-34 : OSM INFO4 (Busy Repeater Message) message

Table 5.2-35 : OSM INFO4 (Free Repeater Message) message

Table 5.2-36 : OSM INFO4 / INFO2 (Site ID Message Message) message

Table 5.2-37 : ISM / OSM INFO4 (EOT) message

Table 5.2-38 : CALL_REQ message from Interoperability Tester

Table 5.2-39 : CALL_RESP message from TR

Table 5.2-40 : REG_REQ message from Interoperability Tester

Table 5.2-41 : REG_RESP message from TR

Table 5.2-42 : TX_REL(Inbound) message from Interoperability Tester

Table 5.2-43 : TX_REL(Outbound) message from TR

Table 5.2-50 : DWR (Header) message from TR

Table 5.2-51 : DWR_ACK message from Interoperability Tester

5.2.20.1. System Data Write during Registration Process

- (1) Carry out operation of (1) shown in Section 5.2.15.1.
- (2) When the Interoperability Tester has transmitted a "REG_REQ" message shown in Table 5.2-15 that includes a "INFO4" message shown in Table 5.1-2 in SCCH, verify that TR transmits a "DWR(Header) and DWR(System Data)" message shown in Table 5.2-15 that includes any of "INFO4" messages shown in Table 5.2-34 to Table 5.2-36 in SCCH.
- (3) When the Interoperability Tester has transmitted a "DWR_ACK" message shown in Table 5.2-15 that includes a "INFO4" message shown in Table 5.1-2 in SCCH, verify that TR transmits a "REG_RESP" message indicating "Accept" shown in Table 5.2-15 that includes any of "INFO4" messages shown in Table 5.2-34 to Table 5.2-36 in SCCH.
- (4) When the Interoperability Tester has transmitted a "TX_REL" (Inbound) message shown in Table 5.2-15 that includes a "INFO4" (EOT) message shown in Table 5.1-2 in SCCH, verify that TR transmits a "TX_REL" (Outbound) message shown in Table 5.2-15 that includes a "INFO4" (EOT) message shown in Table 5.1-2 in SCCH.

5.2.20.2. System Data Write by Trunking Repeater

- (1) Verify that TR transmits an "DWR(Header) and DWR(System Data)" message shown in Table 5.2-48 that includes any of "INFO4" messages shown in Table 5.2-34 to Table 5.2-36 in SCCH.

Table 5.2-50 DWR (Header) message

Data Write Option	00
Source Prefix	00000b
Source Unit ID	7FB as TC ID
Destination Prefix	Prefix of Interoperability Tester
Destination Unit ID	Unit ID of Interoperability Tester
Packet Information	Except for the following, depends on the format to be used for testing. Delivery Flag = 0 Unconfirmed (Group Call, Individual Call) Delivery Flag = 1 Confirmed (Individual Call)

Table 5.2-51 DWR_ACK message

Data Write Option	00
Source Prefix	Prefix of Interoperability Tester
Source Unit ID	Prefix of Interoperability Tester
Destination Prefix	00000b
Destination Unit ID	7FB as TC ID
Response Information	00 001b (Receive Success)
Error Block Flag	0000

5.2.21. Site Roaming Test

This test shall verify that a TR recognizes a roaming SU when the SU roams between sites and that a TR in the site to which the SU migrates sends a message correctly. (Multi Trunked System)

Figure 5.2-3 shows the configuration diagram for testing. TR No. 1 is treated as site 1, and TR No. 2 is treated as site 2. Each RF Traffic channel is treated as RTCH2-1 or RTCH2-2. The connection structure between site 1 and site 2 shall be determined by the respective manufacturer. Amount of attenuation for attenuator 1 to attenuator 4 can be adjusted so that RF interference by transmitting signals does not occur and the receiver input level is sufficient for TR No. 1 and TR No. 2 to acquire inbound signals.

Table 5.2-34 shows conditions of Location ID for site 1 and site is 2.

	Site 1	Site 2
System Code	1	1
Site Type	11b	11b
Site Code	1	2

- (1) Complete the registration of Interoperability tester No. 1 and Interoperability tester No. 2 to TR No. 1.
- (2) Verify that Interoperability tester No.1 outputs received audio signal when Interoperability tester No.2 makes an Individual Voice Call to Interoperability tester No.1.
- (3) Complete the registration of Interoperability tester No.1 to TR No.2 on an RTCH2-2.
- (4) Verify that Interoperability tester No.1 outputs received audio signal when Interoperability tester No.2 makes an Individual Voice Call to Interoperability tester No.1.
- (5) Verify that the measuring instrument 1 outputs vocal data.

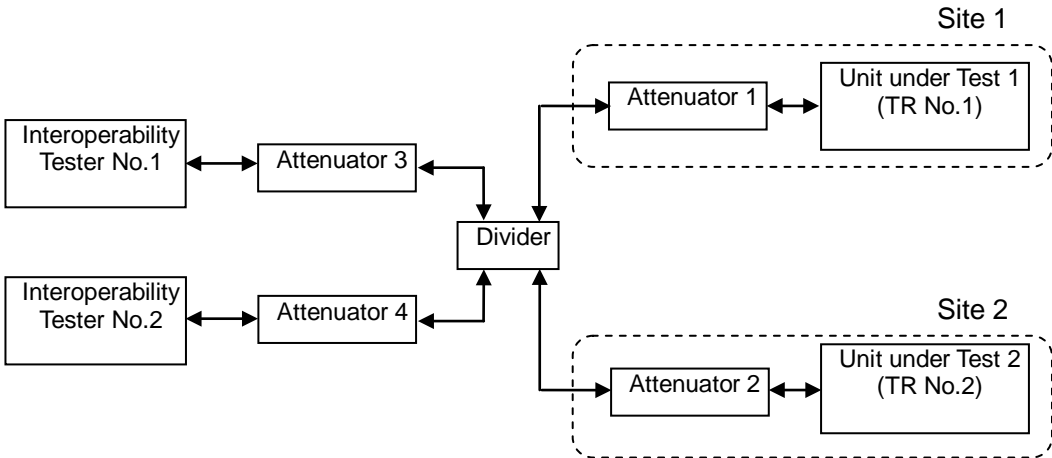

Figure 5.2-3 Site Roaming Test Setup

5.2.22. Halt Repeater Test

In this test, to check whether or not Halt Repeater function of TR operates as intended. The connection configuration of this test is shown in Figure 5.1-4. A Halt Repeater function is affected by specifications of a system, therefore it will be good enough that any one of the following items to be confirmed is checked.

- (1) In the case in which any specified period of time has passed since a Halt Repeater Message shown in Table 5.1-51 was received, or;
- (2) In the case in which criteria stipulated by a manufacturer of TR has been met.

5.2.23. ID Validation Test

The test method to check whether or not ID Validation function operates as intended is the same as those of Link Tests shown section 5.2.2.

Each of the test methods to check whether or not SU operates as intended in response to a valid ID or an invalid ID is shown in section 5.2.2.1 and section 5.2.2.2, respectively.

6. Appendix

6.1. Samples of Test Frame

This section presents samples of frame data to be used for Call testing. Samples of frame data shall be used for Individual Call. The ID to be used for testing are arbitrary; however, the frame data is presented in this section using an ID and so on as described in Table 6.1-1. Also, configuration as described in Table 6.1-2 is used for the encrypted frame data.

Table 6.1-1 IDs Setup for Sample Frame Data

	Single Trunked System		Multi Trunked System	
	Inbound	Outbound	Inbound	Outbound
Area	0b	0b	0b	0b
Repeater in Use	1	-	1	-
Go to Repeater	-	1	-	1
Free Repeater1	2	2	2	2
Free Repeater2	3	3	3	3
Home Repeater	1	1	1	1
Call Type	Individual	Individual	Individual	Individual
Source Prefix	-		1	1
Source Unit ID	1	1	1	1
Destination Prefix	1	1	1	1
Destination Unit ID	2	2	2	2
System ID Option	-		10000b	10000b
System ID	-		1	1

Table 6.1-2 Encryption Setup for Sample Frame Data

	Value
Cipher Type	01b
Key ID	00 0001b
Encryption Key	000 0000 0000 0001b

6.1.1. Frame Data for Single Trunked System

Now, a frame used in Single Trunk System will be shown.

6.1.1.1. Frame Data for Link

6.1.1.1.1. Sample of Link on Inbound

This frame is an inbound frame when a link is being connected.
 A frame configuration will be shown in Figure 6.1-1. Guard Time is primarily arranged at the back of FACCH1, though, here the illustration is omitted. Adjust the Guard Time to operate as desired when conducting a test.

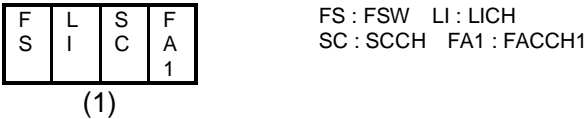

Frame	LICH	SCCH	FACCH1
(1)	first half : FACCH1 second half : G	INFO4	CALL_REQ

Figure 6.1-1 Frame Structure for Link (Inbound)

Frame Data for Link (Inbound)

Frame1	
FSW	CDF59
LICH	FD5F
SCCH	434CE7AE03D22A1
FACCH1	9A8422281AA08E828A402216C80E2881EE0B

6.1.1.1.2. Sample of Link on Outbound

Frame configurations will be shown in Figure 6.1-2 and Figure 6.1-3. Null Data and Post Field are primarily arranged at the back of FACCH1, though, here the illustration is omitted. Adjust the Null Data and Post Field to operate as desired when conducting a test.

F	L	S	F
S	I	C	A
			3

FS : FSW LI : LICH
 SC : SCCH FA3 : FACCH3

(1)

Frame	LICH	SCCH	FACCH3
(1)	FACCH3	INFO4 (Busy Repeater Message)	CALL_CONN_RESP

Figure 6.1-2 Frame Structure for Link (Outbound)

F	L	S	F
S	I	C	A
			1

FS : FSW LI : LICH
 SC : SCCH FA1 : FACCH1

(1)

Frame	LICH	SCCH	FACCH1
(1)	FACCH1	INFO4 (Busy Repeater Message)	CALL_RESP

Figure 6.1-3 Frame Structure for Link (Outbound)

Frame Data for Link (Outbound)

Frame1	
FSW	CDF59
LICH	FF75
SCCH	434CE7AE03D22A1
FACCH3	9A94222C0A899E83C2C462D7A81660ABFB0B 008A028230208228AB212280E88A10A4A803

Frame Data for Link (Outbound)

Frame1	
FSW	CDF59
LICH	FD57
SCCH	434CE7AE03D22A1
FACCH1	9A94222C1AA98A80CB412256A80E3881EE09

6.1.1.2. Frame Data for Voice Call

6.1.1.2.1. Sample of Voice Call on Inbound

This is an inbound frame for voice call. A frame configuration will be shown in Figure 6.1-4.

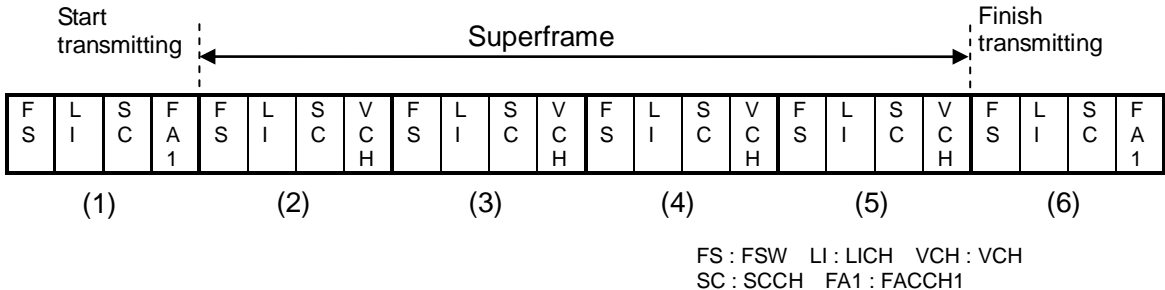

Frame	LICH	SCCH	VCH	VCH	VCH	VCH
			FACCH1	FACCH1	FACCH1	FACCH1
(1)	non-superframe, FACCH1	INFO4,	VCALL	VCALL	VCALL	VCALL
(2)	superframe, VCH	INFO1	Tone Test Pattern			
(3)	superframe, VCH	INFO2	Tone Test Pattern			
(4)	superframe, VCH	INFO3	Tone Test Pattern			
(5)	superframe, VCH	INFO4	Tone Test Pattern			
(6)	non-superframe, FACCH1	INFO4(EOT)	TX REL	TX REL	TX REL	TX REL

Figure 6.1-4 Frame Structure for Voice Call (Inbound)

Frame Data for Voice Call (Inbound)

Frame1	
FSW	CDF59
LICH	FD7F
SCCH	434CE7AE03D22A1
FACCH1	DA2462081AA08E808B402236F83E208BE908
FACCH1	582C4082B0A8A608A368223CFABC00A36B22
Frame2	
FSW	CDF59
LICH	F5DD
SCCH	C6F0764D6144AA1
VCH	4CAADE8B26E4F28288
VCH	C68A7429A4ECD00822
VCH	CEA2FC018CECDA0AA0
VCH	EE8A7E2B26CCF88A08
Frame3	
FSW	CDF59
LICH	F5DD
SCCH	C74FF76E125A280
VCH	4CAADE8B26E4F28288
VCH	C68A7429A4ECD00822
VCH	CEA2FC018CECDA0AA0
VCH	EE8A7E2B26CCF88A08
Frame4	
FSW	CDF59
LICH	F5DD
SCCH	43EBD6A430C6E83
VCH	4CAADE8B26E4F28288
VCH	C68A7429A4ECD00822
VCH	CEA2FC018CECDA0AA0
VCH	EE8A7E2B26CCF88A08
Frame5	
FSW	CDF59
LICH	F5DD
SCCH	434CE7AE03D22A1
VCH	4CAADE8B26E4F28288
VCH	C68A7429A4ECD00822
VCH	CEA2FC018CECDA0AA0
VCH	EE8A7E2B26CCF88A08
Frame6	
FSW	CDF59
LICH	FD7F
SCCH	410CF3CD13CEE80
FACCH1	9A8422081AA88C808AC122B6E8063889EC0A
FACCH1	188C0082B0A0A408A2E922BCEA8418A16E20

6.1.1.2.2. Sample of Voice Call on Outbound

This is an outbound frame for voice call. A frame configuration will be shown in Figure 6.1-5.

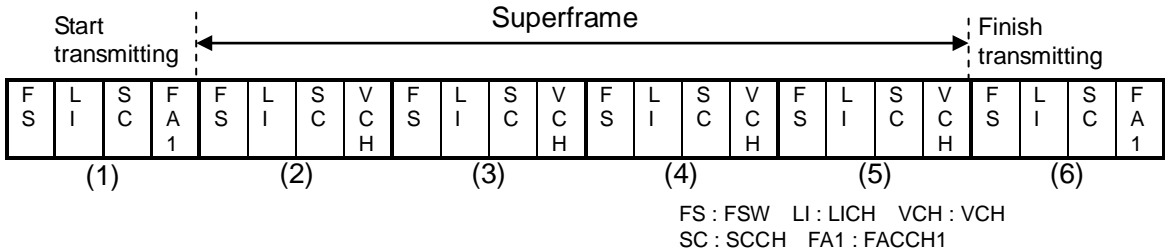

Frame	LICH	SCCH	V	V	V	V
			C	C	C	C
			H	H	H	H
(1)	non-superframe, FACCH1	INFO4(Busy Repeater Message)	FACCH1		FACCH1	
(2)	superframe, VCH	INFO1	Tone Test Pattern			
(3)	superframe, VCH	INFO2(Busy Repeater Message)	Tone Test Pattern			
(4)	superframe, VCH	INFO3	Tone Test Pattern			
(5)	superframe, VCH	INFO4(Busy Repeater Message)	Tone Test Pattern			
(6)	non-superframe, FACCH1	INFO4(EOT)	TX REL		TX REL	

Figure 6.1-5 Frame Structure for Voice Call (Outbound)

Frame Data for Voice Call (Outbound)

Frame1	
FSW	CDF59
LICH	FD77
SCCH	434CE7AE03D22A1
FACCH1	DA2462081AA08E808B402236F83E208BE908
FACCH1	582C4082B0A8A608A368223CFABC00A36B22
Frame2	
FSW	CDF59
LICH	F5D5
SCCH	AEE2626D02544D9
VCH	4CAADE8B26E4F28288
VCH	C68A7429A4ECD00822
VCH	CEA2FC018CECDA0AA0
VCH	EE8A7E2B26CCF88A08
Frame3	
FSW	CDF59
LICH	F5D5
SCCH	C74FF76E125A280
VCH	4CAADE8B26E4F28288
VCH	C68A7429A4ECD00822
VCH	CEA2FC018CECDA0AA0
VCH	EE8A7E2B26CCF88A08
Frame4	
FSW	CDF59
LICH	F5D5
SCCH	03EB42A55BDECB2
VCH	4CAADE8B26E4F28288
VCH	C68A7429A4ECD00822
VCH	CEA2FC018CECDA0AA0
VCH	EE8A7E2B26CCF88A08
Frame5	
FSW	CDF59
LICH	F5D5
SCCH	434CE7AE03D22A1
VCH	4CAADE8B26E4F28288
VCH	C68A7429A4ECD00822
VCH	CEA2FC018CECDA0AA0
VCH	EE8A7E2B26CCF88A08
Frame6	
FSW	CDF59
LICH	FD77
SCCH	410CF3CD13CEE0
FACCH1	9A94220C1AA18882CBC022F688062889EC08
FACCH1	189C0086B0A9A00AE3E822FC8A8408A16E22

6.1.1.3. Frame Data for Short Data Call

6.1.1.3.1. Sample of Short Data Call on Inbound

This is an inbound frame for short data call. A frame configuration will be shown in Figure 6.1-6.

Packet Information used for displaying a configuration illustration of transmission packet for data communication will be shown in Table 6.1-3.

Table 6.1-3 Packet Information for Short Data Call

Bit	7	6	5	4	3	2	1	0
Octet8	0	0	0	0	0	1	1	0
Octet9	0	0	0	0	0	1	0	0

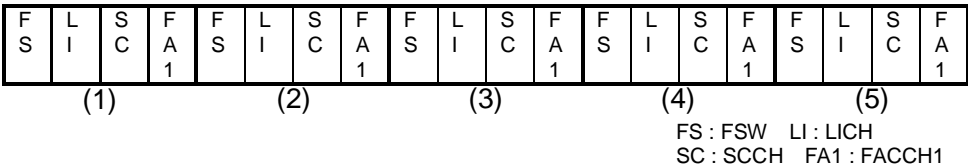

Frame	LICH	SCCH	FACCH1	FACCH1
(1)	FACCH1	INFO4	SDCALL_REQ(Header)	SDCALL_REQ(User Data) Data=3031323334353637
(2)	FACCH1	INFO4	SDCALL_REQ(User Data) Data=38393A3B3C3D3E3F	SDCALL_REQ(User Data) Data=4041424344454647
(3)	FACCH1	INFO4	SDCALL_REQ(User Data) Data=48494A4B4C4D4E4F	SDCALL_REQ(User Data) Data=5051525354555657
(4)	FACCH1	INFO4	SDCALL_REQ(User Data) Data=58595A5B5C5D5E5F	SDCALL_REQ(User Data) Data=60616263
(5)	FACCH1	INFO4(EOT)	TX_REL	TX_REL

Figure 6.1-6 Frame Structure for Short Data Call (Inbound)

Frame Data for Short Data Call (Inbound)

Frame1	
FSW	CDF59
LICH	FD7F
SCCH	434CE7AE03D22A1
FACCH1	9A84623822B888818D42A3D6F8060889E40E
FACCH1	6BAB1F9F38E87839D3542F360DF43460A48B
Frame2	
FSW	CDF59
LICH	FD7F
SCCH	434CE7AE03D22A1
FACCH1	9FA3767D943A50DD7B678F21AF61664595A2
FACCH1	62869051E9C1C8C7087039A9CEB0BEBD5FE4
Frame3	
FSW	CDF59
LICH	FD7F
SCCH	434CE7AE03D22A1
FACCH1	96AEE9B35513E4232103396E0C35E8966ACD
FACCH1	4F10497D687110E11B06A2FD64C679D3CAAE
Frame4	
FSW	CDF59
LICH	FD7F
SCCH	434CE7AE03D22A1
FACCH1	BB18209FC4A33805B33502EAC6532BF6FB87
FACCH1	673081B219E104C9ED3104BB231001C36B5A
Frame5	
FSW	CDF59
LICH	FD7F
SCCH	410CF3CD13CEE0
FACCH1	9A8422081AA88C808AC122B6E8063889EC0A
FACCH1	188C0082B0A0A408A2E922BCEA8418A16E20

6.1.1.3.2. Sample of Short Data Call on Outbound

This is an outbound frame for short data call. A frame configuration will be shown in Figure 6.1-7.

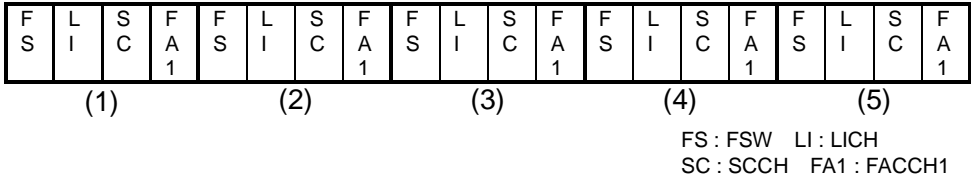

Frame	LICH	SCCH	FACCH1	FACCH1
(1)	FACCH1	INFO4 (Busy Repeater Message)	SDCALL_REQ(Header)	SDCALL_REQ(User Data) Data=3031323334353637
(2)	FACCH1	INFO4 (Free Repeater Message)	SDCALL_REQ(User Data) Data=38393A3B3C3D3E3F	SDCALL_REQ(User Data) Data=4041424344454647
(3)	FACCH1	INFO4 (Busy Repeater Message)	SDCALL_REQ(User Data) Data=48494A4B4C4D4E4F	SDCALL_REQ(User Data) Data=5051525354555657
(4)	FACCH1	INFO4 (Free Repeater Message)	SDCALL_REQ(User Data) Data=58595A5B5C5D5E5F	SDCALL_REQ(User Data) Data=60616263
(5)	FACCH1	INFO4(EOT)	TX_REL	TX_REL

Figure 6.1-7 Frame Structure for Short Data Call (Outbound)

Frame Data for Short Data Call (Outbound)

Frame1	
FSW	CDF59
LICH	FD77
SCCH	434CE7AE03D22A1
FACCH1	9A84623822B888818D42A3D6F8060889E40E
FACCH1	6BAB1F9F38E87839D3542F360DF43460A48B
Frame2	
FSW	CDF59
LICH	FD77
SCCH	0BCC6033A2E8154
FACCH1	9FA3767D943A50DD7B678F21AF61664595A2
FACCH1	62869051E9C1C8C7087039A9CEB0BEBD5FE4
Frame3	
FSW	CDF59
LICH	FD77
SCCH	434CE7AE03D22A1
FACCH1	96AEE9B35513E4232103396E0C35E8966ACD
FACCH1	4F10497D687110E11B06A2FD64C679D3CAAE
Frame4	
FSW	CDF59
LICH	FD77
SCCH	0BCC6033A2E8154
FACCH1	BB18209FC4A33805B33502EAC6532BF6FB87
FACCH1	673081B219E104C9ED3104BB231001C36B5A
Frame5	
FSW	CDF59
LICH	FD77
SCCH	410CF3CD13CEE0
FACCH1	9A94220C1AA18882CBC022F688062889EC08
FACCH1	189C0086B0A9A00AE3E822FC8A8408A16E22

6.1.1.4. Frame Data for Data Call

6.1.1.4.1. Sample of Data Call on Inbound

This is an inbound frame for data call.
 A frame configuration will be shown in Figure 6.1-8.

Packet Information used for displaying a configuration illustration of transmission packet for data communication will be shown in Table 6.1-4.

Table 6.1-4 Packet Information for Data Call

Bit	7	6	5	4	3	2	1	0
Octet8	0	0	0	0	0	0	0	1
Octet9	0	0	0	0	0	1	0	0
Octet10	0	0	0	0	0	0	0	0

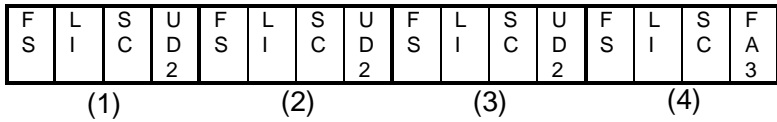

FS : FSW LI : LICH UD2 : UDCH2
 SC : SCCH FA3 : FACCH3

Frame	LICH	SCCH	UDCH2
			FACCH3
(1)	UDCH2	INFO4	DCALL(Header)
(2)	UDCH2	INFO4	DCALL(User Data) Data=303132333435363738393A3B3C3D3E3F4041
(3)	UDCH2	INFO4	DCALL(User Data) Data=42434445464748494A4B4C4D4E4F
(4)	FACCH3	INFO4(EOT)	TX_REL

Figure 6.1-8 Frame Structure for Data Call (Inbound)

Frame Data for Data Call (Inbound)

Frame1	
FSW	CDF59
LICH	FFDD
SCCH	434CE7AE03D22A1
UDCH2	DB24E2282AB0888088C1A2167856208BE70F 008A028230208228AB212280E88A10A4A803
Frame2	
FSW	CDF59
LICH	FFDD
SCCH	434CE7AE03D22A1
UDCH2	A9032D0D8EE254B0FABD6FDC0F52164220A0 5C11D4789A910155BD56A6D9FC82435D51E3
Frame3	
FSW	CDF59
LICH	FFDD
SCCH	434CE7AE03D22A1
UDCH2	E035E28CBB408C40CD80D0D10D2387B790A2 21ECAF2C41D6CA21BF76782478C4804E8537
Frame4	
FSW	CDF59
LICH	FF7D
SCCH	410CF3CD13CEE00
FACCH3	9A8422081AA88C808AC122B6E8063889EC0A 008A028230208228AB212280E88A10A4A803

6.1.1.4.2. Sample of Data Call on Outbound

This is an outbound frame for data call.
 A frame configuration will be shown in Figure 6.1-9.

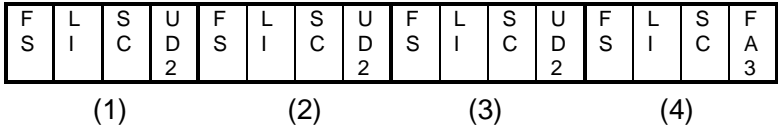

FS : FSW LI : LICH UD2 : UDCH2
 SC : SCCH FA3 : FACCH3

Frame	LICH	SCCH	UDCH2
			FACCH3
(1)	UDCH2	INFO4 (Busy Repeater Message)	DCALL(Header)
(2)	UDCH2	INFO4 (Free Repeater Message)	DCALL(User Data) Data=303132333435363738393A3B3C3D3E3F4041
(3)	UDCH2	INFO4 (Busy Repeater Message)	DCALL(User Data) Data=42434445464748494A4B4C4D4E4F
(4)	FACCH3	INFO4(EOT)	TX_REL

Figure 6.1-9 Frame Structure for Data Call (Outbound)

Frame Data for Data Call (Outbound)

Frame1	
FSW	CDF59
LICH	FFD5
SCCH	434CE7AE03D22A1
UDCH2	DB24E2282AB0888088C1A2167856208BE70F 008A028230208228AB212280E88A10A4A803
Frame2	
FSW	CDF59
LICH	FFD5
SCCH	0BCC6033A2E8154
UDCH2	A9032D0D8EE254B0FABD6FDC0F52164220A0 5C11D4789A910155BD56A6D9FC82435D51E3
Frame3	
FSW	CDF59
LICH	FFD5
SCCH	434CE7AE03D22A1
UDCH2	E035E28CBB408C40CD80D0D10D2387B790A2 21ECAF2C41D6CA21BF76782478C4804E8537
Frame4	
FSW	CDF59
LICH	FF75
SCCH	410CF3CD13CEE0
FACCH3	9A94220C1AA18882CBC022F688062889EC08 008A028230208228AB212280E88A10A4A803

6.1.1.5. Frame Data for Status Call

6.1.1.5.1. Sample of Status Call on Inbound

This is an inbound frame for status call.

A frame configuration will be shown in Figure 6.1-10 and Figure 6.1-11.

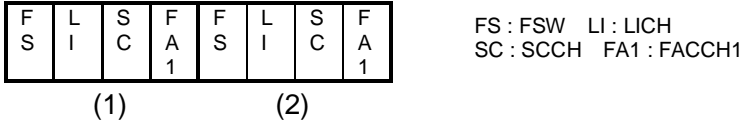

Frame	LICH	SCCH	FACCH1	FACCH1
(1)	FA1	INFO4	STAT_REQ Status = 1	STAT_REQ Status = 1
(2)	FA1	INFO4(EOT)	TX_REL	TX_REL

Figure 6.1-10 Frame Structure for Data Call using FACCH1 (Inbound)

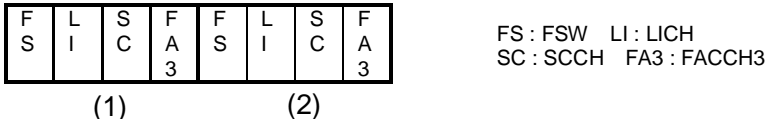

Frame	LICH	SCCH	FACCH3
(1)	FA3	INFO4	STAT_REQ Status = 1
(2)	FA3	INFO4(EOT)	TX_REL

Figure 6.1-11 Frame Structure for Data Call using FACCH3 (Inbound)

Frame Data for Status Call Using FACCH1 (Inbound)

Frame1	
FSW	CDF59
LICH	FD7F
SCCH	434CE7AE03D22A1
FACCH1	9B04A23802A08E838AC0E2F6086E2C81E70D
FACCH1	190C80B2A8A8A60BA2E8E2FC0AEC0CA96527
Frame2	
FSW	CDF59
LICH	FD7F
SCCH	410CF3CD13CEE0
FACCH1	9A8422081AA88C808AC122B6E8063889EC0A 188C0082B0A0A408A2E922BCEA8418A16E20

Frame Data for Status Call Using FACCH3 (Inbound)

Frame1	
FSW	CDF59
LICH	FF7D
SCCH	434CE7AE03D22A1
FACCH3	9B04A23802A08E838AC0E2F6086E2C81E70D 008A028230208228AB212280E88A10A4A803
Frame2	
FSW	CDF59
LICH	FF7D
SCCH	410CF3CD13CEE0
FACCH3	9A8422081AA88C808AC122B6E8063889EC0A 008A028230208228AB212280E88A10A4A803

6.1.1.5.2. Sample of Status Call on Outbound

This is an outbound frame for status call.

A frame configuration will be shown in Figure 6.1-12 and Figure 6.1-13.

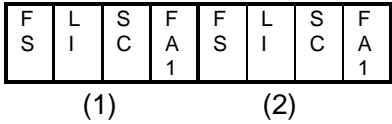

FS : FSW LI : LICH
 SC : SCCH FA1 : FACCH1

Frame	LICH	SCCH	FACCH1	FACCH1
(1)	FA1	INFO4 (Busy Repeater Message)	STAT_REQ Status =1	STAT_REQ Status = 1
(2)	FA1	INFO4(EOT)	TX_REL	TX_REL

Figure 6.1-12 Frame Structure for Data Call using FACCH1 (Outbound)

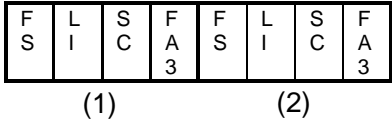

FS : FSW LI : LICH
 SC : SCCH FA3 : FACCH3

Frame	LICH	SCCH	FACCH3
(1)	FA3	INFO4 (Busy Repeater Message)	STAT_REQ Status = 1
(2)	FA3	INFO4(EOT)	TX_REL

Figure 6.1-13 Frame Structure for Data Call using FACCH3 (Outbound)

Frame Data for Status Call Using FACCH1 (Outbound)

Frame1	
FSW	CDF59
LICH	FD77
SCCH	434CE7AE03D22A1
FACCH1	9B04A23802A08E838AC0E2F6086E2C81E70D
FACCH1	190C80B2A8A8A60BA2E8E2FC0AEC0CA96527
Frame2	
FSW	CDF59
LICH	FD77
SCCH	410CF3CD13CEE0
FACCH1	9A94220C1AA18882CBC022F688062889EC08
FACCH1	189C0086B0A9A00AE3E822FC8A8408A16E22

Frame Data for Status Call Using FACCH3 (Outbound)

Frame1	
FSW	CDF59
LICH	FF75
SCCH	434CE7AE03D22A1
FACCH3	9B04A23802A08E838AC0E2F6086E2C81E70D 008A028230208228AB212280E88A10A4A803
Frame2	
FSW	CDF59
LICH	FF75
SCCH	410CF3CD13CEE0
FACCH3	9A94220C1AA18882CBC022F688062889EC08 008A028230208228AB212280E88A10A4A803

6.1.1.6. Frame Data for Scramble Encrypted Voice Call**6.1.1.6.1. Sample of Scramble Encrypted Voice Call on Inbound**

This is an inbound frame for scramble encrypted voice call. A frame configuration will be the same as shown in Figure 6.1-4.

Frame Data for Scramble Encrypted Voice Call (Inbound)

Frame1	
FSW	CDF59
LICH	FD7F
SCCH	434CE7AE03D22A1
FACCH1	DAA422A85A88BE908B40A0F798AE6087F900
FACCH1	58AC0022F0809618A368A0FD9A2C40AF7B2A
Frame2	
FSW	CDF59
LICH	F5DD
SCCH	DEB04651245DA46
VCH	A8AED8CF46802ED6E6
VCH	E4AC757B2F70DE8CA2
VCH	A08AD01F8CC803C6C8
VCH	BF367D6BA70E11CE4F
Frame3	
FSW	CDF59
LICH	F5DD
SCCH	C74FF76E125A280
VCH	357F85387D1193AE4A
VCH	A4EE135D5B08388C2E
VCH	C1DA5DE3A8AC834F45
VCH	D5287D6DB642F5C252
Frame4	
FSW	CDF59
LICH	F5DD
SCCH	43EB D6A4 30C6 E83
VCH	127B42DC1A1598C13A
VCH	9D590EAE70C0FEE644
VCH	E28CA665EE8C030A84
VCH	32AE3D29810B540DEA
Frame5	
FSW	CDF59
LICH	F5DD
SCCH	434CE7AE03D22A1
VCH	775DD21293BDCEE2A2
VCH	476A163BB88F0007F2
VCH	DE2D542BE2A2A1E127
VCH	2EAE3D2BD627BC9C66
Frame6	
FSW	CDF59
LICH	FD7F
SCCH	410CF3CD13CEEBO
FACCH1	9A8422081AA88C808AC122B6E8063889EC0A
FACCH1	188C0082B0A0A408A2E922BCEA8418A16E20

6.1.1.6.2. Sample of Scramble Encrypted Voice Call on Outbound

This is an outbound frame for scramble encrypted voice call. A frame configuration will be the same as shown in Figure 6.1-5.

Frame Data for Scramble Encrypted Voice Call (Outbound)

Frame1	
FSW	CDF59
LICH	FD77
SCCH	434CE7AE03D22A1
FACCH1	DAA422A85A88BE908B40A0F798AE6087F900
FACCH1	58AC0022F0809618A368A0FD9A2C40AF7B2A
Frame2	
FSW	CDF59
LICH	F5D5
SCCH	B6A25271474D43E
VCH	A8AED8CF46802ED6E6
VCH	E4AC757B2F70DE8CA2
VCH	A08AD01F8CC803C6C8
VCH	BF367D6BA70E11CE4F
Frame3	
FSW	CDF59
LICH	F5D5
SCCH	C74FF76E125A280
VCH	357F85387D1193AE4A
VCH	A4EE135D5B08388C2E
VCH	C1DA5DE3A8AC834F45
VCH	D5287D6DB642F5C252
Frame4	
FSW	CDF59
LICH	F5D5
SCCH	03EB42A55BDECB2
VCH	127B42DC1A1598C13A
VCH	9D590EAE70C0FEE644
VCH	E28CA665EE8C030A84
VCH	32AE3D29810B540DEA
Frame5	
FSW	CDF59
LICH	F5D5
SCCH	434CE7AE03D22A1
VCH	775DD21293BDCEE2A2
VCH	476A163BB88F0007F2
VCH	DE2D542BE2A2A1E127
VCH	2EAE3D2BD627BC9C66
Frame6	
FSW	CDF59
LICH	FD77
SCCH	410CF3CD13CEE0
FACCH1	9A94220C1AA18882CBC022F688062889EC08
FACCH1	189C0086B0A9A00AE3E822FC8A8408A16E22

6.1.1.7. Frame Data for Scramble Encrypted Short Data Call

6.1.1.7.1. Sample of Scramble Encrypted Short Data Call on Inbound

This is an inbound frame for scramble encrypted short data call. A frame configuration will be the same as shown in Figure 6.1-6.

Frame Data for Scramble Encrypted Short Data Call (Inbound)

Frame1	
F5W	CDF59
LICH	FD7F
SCCH	434CE7AE03D22A1
FACCH1	9A0422986290B8918D42211798964885F406
FACCH1	682ADB1C3978B839D119ADA44C502C5D3CCF
Frame2	
F5W	CDF59
LICH	FD7F
SCCH	434CE7AE03D22A1
FACCH1	9F20BC9944DA0049147386E00FE28F811BF1
FACCH1	7801DDD6B9B19065604EA7EB0AA347FD17D8
Frame3	
F5W	CDF59
LICH	FD7F
SCCH	434CE7AE03D22A1
FACCH1	8020E29736EA086F1B1EBDA76A90E2F20A65
FACCH1	4D98481EE8F170C70C21B57FE4A449631688
Frame4	
F5W	CDF59
LICH	FD7F
SCCH	434CE7AE03D22A1
FACCH1	919664B8545A28A1EF13076F40B740D2E9BC
FACCH1	49B50930E9D97C51D62B083AC796DABFA30C
Frame5	
F5W	CDF59
LICH	FD7F
SCCH	410CF3CD13CEE0
FACCH1	9A8422081AA88C808AC122B6E8063889EC0A
FACCH1	188C0082B0A0A408A2E922BCEA8418A16E20

6.1.1.7.2. Sample of Scramble Encrypted Short Data Call on Outbound

This is an outbound frame for scramble encrypted short data call. A frame configuration will be the same as shown in Figure 6.1-7.

Frame Data for Scramble Encrypted Short Data Call (Outbound)

Frame1	
F5W	CDF59
LICH	FD77
SCCH	434CE7AE03D22A1
FACCH1	9A0422986290B8918D42211798964885F406
FACCH1	682ADB1C3978B839D119ADA44C502C5D3CCF
Frame2	
F5W	CDF59
LICH	FD77
SCCH	0BCC6033A2E8154
FACCH1	9F20BC9944DA0049147386E00FE28F811BF1
FACCH1	7801DDD6B9B19065604EA7EB0AA347FD17D8
Frame3	
F5W	CDF59
LICH	FD77
SCCH	434CE7AE03D22A1
FACCH1	8020E29736EA086F1B1EBDA76A90E2F20A65
FACCH1	4D98481EE8F170C70C21B57FE4A449631688
Frame4	
F5W	CDF59
LICH	FD77
SCCH	0BCC6033A2E8154
FACCH1	919664B8545A28A1EF13076F40B740D2E9BC
FACCH1	49B50930E9D97C51D62B083AC796DABFA30C
Frame5	
F5W	CDF59
LICH	FD77
SCCH	410CF3CD13CEE80
FACCH1	9A94220C1AA18882CBC022F688062889EC08
FACCH1	189C0086B0A9A00AE3E822FC8A8408A16E22

6.1.1.8. Frame Data for Scramble Encrypted Data Call

6.1.1.8.1. Sample of Scramble Encrypted Data Call on Inbound

This is an inbound frame for scramble encrypted data call. A frame configuration will be the same as shown in Figure 6.1-8.

Frame Data for Scramble Encrypted Data Call (Inbound)

Frame1	
FSW	CDF59
LICH	FFDD
SCCH	434CE7AE03D22A1
UDCH2	DBA4A2886A98B89088C120D718C66087F707008A028230208228AB212280E88A10A4A803
Frame2	
FSW	CDF59
LICH	FFDD
SCCH	434CE7AE03D22A1
UDCH2	AA82E98E8F7294B0F8F0ED4E4EF60E7FB8E4758317D9FD6298451D57A8B22FC1CA13085F
Frame3	
FSW	CDF59
LICH	FFDD
SCCH	434CE7AE03D22A1
UDCH2	DCA9E74CD88008D2B0A84C57E84266C71400111DD71F2E4184446D9A5AEC2CFC53199C71
Frame4	
FSW	CDF59
LICH	FF7D
SCCH	410CF3CD13CEE80
FACCH3	9A8422081AA88C808AC122B6E8063889EC0A008A028230208228AB212280E88A10A4A803

6.1.1.8.2. Sample of Scramble Encrypted Data Call on Outbound

This is an outbound frame for scramble encrypted data call. A frame configuration will be the same as shown in Figure 6.1-9.

Frame Data for Scramble Encrypted Data Call (Outbound)

Frame1	
FSW	CDF59
LICH	FFD5
SCCH	434CE7AE03D22A1
UDCH2	DBA4A2886A98B89088C120D718C66087F707008A028230208228AB212280E88A10A4A803
Frame2	
FSW	CDF59
LICH	FFD5
SCCH	0BCC6033A2E8154
UDCH2	AA82E98E8F7294B0F8F0ED4E4EF60E7FB8E4758317D9FD6298451D57A8B22FC1CA13085F
Frame3	
FSW	CDF59
LICH	FFD5
SCCH	434CE7AE03D22A1
UDCH2	DCA9E74CD88008D2B0A84C57E84266C71400111DD71F2E4184446D9A5AEC2CFC53199C71
Frame4	
FSW	CDF59
LICH	FF75
SCCH	410CF3CD13CEE80
FACCH3	9A94220C1AA18882CBC022F688062889EC08008A028230208228AB212280E88A10A4A803

6.1.2.Frame Data for Multi Trunked System

Now, a frame used in Multi Trunk System will be shown.

6.1.2.1. Frame Data for Link

6.1.2.1.1. Sample of Link on Inbound

This frame is an inbound frame when a link is being connected.
 A frame configuration will be shown in Figure 6.1-14. Guard Time is primarily arranged at the back of FACCH1, though, here the illustration is omitted. Adjust the Guard Time to operate as desired when conducting a test.

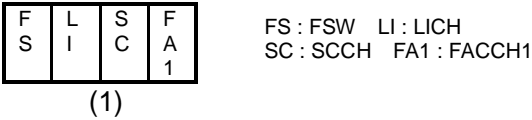

Frame	LICH	SCCH	FACCH1
(1)	first half : FACCH1 second half : G	INFO4	CALL_REQ

Figure 6.1-14 Frame Structure for Link (Inbound)

Frame Data for Link (Inbound)

Frame1	
FSW	CDF59
LICH	FD5F
SCCH	434CE7AE03D22A1
FACCH1	DAA422280EE28F960945A217C81E2885EE0B

6.1.2.1.2. Sample of Link on Outbound

A frame configuration will be shown in Figure 6.1-15 and Figure 6.1-16.

F	L	S	F
S	I	C	A
			3

FS : FSW LI : LICH
SC : SCCH FA3 : FACCH3

(1)

Frame	LICH	SCCH	FACCH3
(1)	FACCH3	INFO4 (Busy Repeater Message)	CALL_CONN_RESP

Figure 6.1-15 Frame Structure for Link (Outbound)

F	L	S	F
S	I	C	A
			1

FS : FSW LI : LICH
SC : SCCH FA1 : FACCH1

(1)

Frame	LICH	SCCH	FACCH1
(1)	FACCH1	INFO4 (Busy Repeater Message)	CALL_RESP

Figure 6.1-16 Frame Structure for Link (Outbound)

Frame Data for Link (Outbound)

Frame1	
FSW	CDF59
LICH	FF75
SCCH	434CE7AE03D22A1
FACCH3	D8B462AC1EAB9F8942C46297881678A7FD0A402A42A23020822AAA2122A0D8BA18AEAF00

Frame Data for Link (Outbound)

Frame1	
FSW	CDF59
LICH	FD57
SCCH	434CE7AE03D22A1
FACCH1	DAB4222C0EEB8B944844A257A81E3885EE09

6.1.2.2. Frame Data for Voice Call

6.1.2.2.1. Sample of Voice Call on Inbound

This is an inbound frame for voice call. A frame configuration will be shown in Figure 6.1-17.

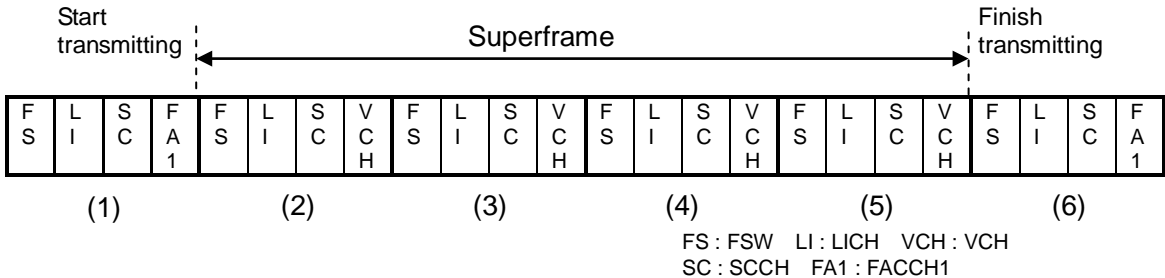

Frame	LICH	SCCH	VCH	VCH	VCH	VCH
			FACCH1	FACCH1	FACCH1	FACCH1
(1)	non-superframe, FACCH1	INFO4	VCALL	VCALL	VCALL	VCALL
(2)	superframe, VCH	INFO1	Tone Test Pattern			
(3)	superframe, VCH	INFO2	Tone Test Pattern			
(4)	superframe, VCH	INFO3	Tone Test Pattern			
(5)	superframe, VCH	INFO4	Tone Test Pattern			
(6)	non-superframe, FACCH1	INFO4(EOT)	TX REL	TX REL	TX REL	TX REL

Figure 6.1-17 Frame Structure for Voice Call (Inbound)

Frame Data for Voice Call (Inbound)

Frame1	
FSW	CDF59
LICH	FD7F
SCCH	434CE7AE03D22A1
FACCH1	9A0422081EA28F800A41A276B80E288BE90A
FACCH1	180C0082B4AAA7082269A27CBA8C08A36B20
Frame2	
FSW	CDF59
LICH	F5DD
SCCH	E6FA64D9E45CAE3
VCH	4CAADE8B26E4F28288
VCH	C68A7429A4ECD00822
VCH	CEA2FC018CECDA0AA0
VCH	EE8A7E2B26CCF88A08
Frame3	
FSW	CDF59
LICH	F5DD
SCCH	C74FF76E125A280
VCH	4CAADE8B26E4F28288
VCH	C68A7429A4ECD00822
VCH	CEA2FC018CECDA0AA0
VCH	EE8A7E2B26CCF88A08
Frame4	
FSW	CDF59
LICH	F5DD
SCCH	43EBD6A430C6E83
VCH	4CAADE8B26E4F28288
VCH	C68A7429A4ECD00822
VCH	CEA2FC018CECDA0AA0
VCH	EE8A7E2B26CCF88A08
Frame5	
FSW	CDF59
LICH	F5DD
SCCH	434CE7AE03D22A1
VCH	4CAADE8B26E4F28288
VCH	C68A7429A4ECD00822
VCH	CEA2FC018CECDA0AA0
VCH	EE8A7E2B26CCF88A08
Frame6	
FSW	CDF59
LICH	FD7F
SCCH	410CF3CD13CEE80
FACCH1	DAA462081EAA8D800BC0A2F6A8363089EC08
FACCH1	58AC4082B4A2A50823E8A2FCAAB410A16E22

6.1.2.2.2. Sample of Voice Call on Outbound

This is an outbound frame for voice call. A frame configuration will be shown in Figure 6.1-18.

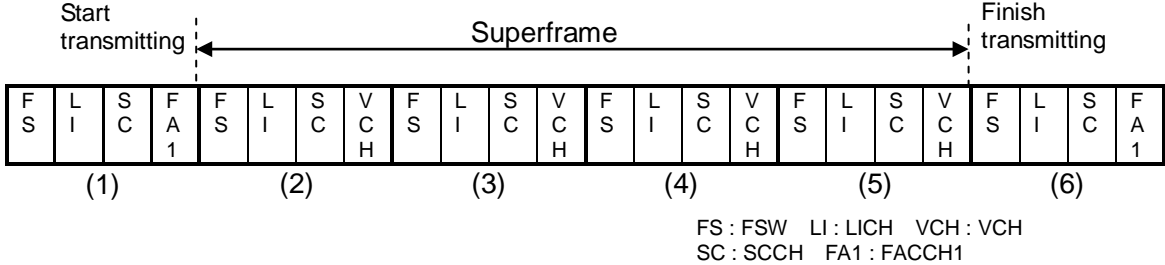

Frame	LICH	SCCH	V	V	V	V
			C	C	C	C
			H	H	H	H
(1)	non-superframe, FACCH1	INFO4(Busy Repeater Message)	FACCH1		FACCH1	
(2)	superframe, VCH	INFO1	Tone Test Pattern			
(3)	superframe, VCH	INFO2(Busy Repeater Message)	Tone Test Pattern			
(4)	superframe, VCH	INFO3	Tone Test Pattern			
(5)	superframe, VCH	INFO4(Busy Repeater Message)	Tone Test Pattern			
(6)	non-superframe, FACCH1	INFO4(EOT)	TX REL		TX REL	

Figure 6.1-18 Frame Structure for Voice Call (Outbound)

Frame Data for Voice Call (Outbound)

Frame1	
FSW	CDF59
LICH	FD77
SCCH	434CE7AE03D22A1
FACCH1	9A0422081EA28F800A41A276B80E288BE90A
FACCH1	180C0082B4AAA7082269A27CBA8C08A36B20
Frame2	
FSW	CDF59
LICH	F5D5
SCCH	8EE870F9874C49B
VCH	4CAADE8B26E4F28288
VCH	C68A7429A4ECD00822
VCH	CEA2FC018CECDA0AA0
VCH	EE8A7E2B26CCF88A08
Frame3	
FSW	CDF59
LICH	F5D5
SCCH	C74FF76E125A280
VCH	4CAADE8B26E4F28288
VCH	C68A7429A4ECD00822
VCH	CEA2FC018CECDA0AA0
VCH	EE8A7E2B26CCF88A08
Frame4	
FSW	CDF59
LICH	F5D5
SCCH	03EB42A55BDECB2
VCH	4CAADE8B26E4F28288
VCH	C68A7429A4ECD00822
VCH	CEA2FC018CECDA0AA0
VCH	EE8A7E2B26CCF88A08
Frame5	
FSW	CDF59
LICH	F5D5
SCCH	434CE7AE03D22A1
VCH	4CAADE8B26E4F28288
VCH	C68A7429A4ECD00822
VCH	CEA2FC018CECDA0AA0
VCH	EE8A7E2B26CCF88A08
Frame6	
FSW	CDF59
LICH	FD77
SCCH	410CF3CD13CEE0
FACCH1	DAB4620C1EA389824AC1A2B6C8362089EC0A
FACCH1	58BC4086B4ABA10A62E9A2BCCAB400A16E20

6.1.2.3. Frame Data for Short Data Call

6.1.2.3.1. Sample of Short Data Call on Inbound

This is an inbound frame for short data call. A frame configuration will be shown in Figure 6.1-19.

Packet Information used for displaying a configuration illustration of transmission packet for data communication will be shown in Table 6.1-5.

Table 6.1-5 Packet Information for Short Data Call

Bit	7	6	5	4	3	2	1	0
Octet8	0	0	0	0	0	1	1	0
Octet9	0	0	0	0	0	1	0	0

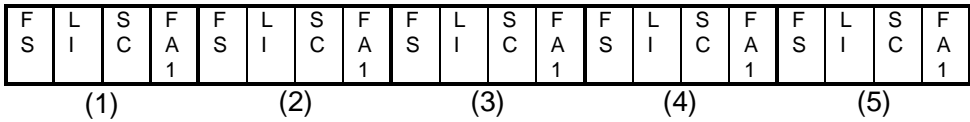

FS : FSW LI : LICH
 SC : SCCH FA1 : FACCH1

Frame	LICH	SCCH	FACCH1	FACCH1
(1)	FACCH1	INFO4	SDCALL_REQ(Header)	SDCALL_REQ(User Data) Data=3031323334353637
(2)	FACCH1	INFO4	SDCALL_REQ(User Data) Data=38393A3B3C3D3E3F	SDCALL_REQ(User Data) Data=4041424344454647
(3)	FACCH1	INFO4	SDCALL_REQ(User Data) Data=48494A4B4C4D4E4F	SDCALL_REQ(User Data) Data=5051525354555657
(4)	FACCH1	INFO4	SDCALL_REQ(User Data) Data=58595A5B5C5D5E5F	SDCALL_REQ(User Data) Data=60616263
(5)	FACCH1	INFO4(EOT)	TX_REL	TX_REL

Figure 6.1-19 Frame Structure for Short Data Call (Inbound)

Frame Data for Short Data Call (Inbound)

Frame1	
F5W	CDF59
LICH	FD7F
SCCH	434CE7AE03D22A1
FACCH1	DAA4223826BA89810C432396B8360089E40C
FACCH1	6BAB1F9F38E87839D3542F360DF43460A48B
Frame2	
F5W	CDF59
LICH	FD7F
SCCH	434CE7AE03D22A1
FACCH1	9FA3767D943A50DD7B678F21AF61664595A2
FACCH1	62869051E9C1C8C7087039A9CEB0BEBD5FE4
Frame3	
F5W	CDF59
LICH	FD7F
SCCH	434CE7AE03D22A1
FACCH1	96AEE9B35513E4232103396E0C35E8966ACD
FACCH1	4F10497D687110E11B06A2FD64C679D3CAAE
Frame4	
F5W	CDF59
LICH	FD7F
SCCH	434CE7AE03D22A1
FACCH1	BB18209FC4A33805B33502EAC6532BF6FB87
FACCH1	673081B219E104C9ED3104BB231001C36B5A
Frame5	
F5W	CDF59
LICH	FD7F
SCCH	410CF3CD13CEE0
FACCH1	DAA462081EAA8D800BC0A2F6A8363089EC08
FACCH1	58AC4082B4A2A50823E8A2FCAAB410A16E22

6.1.2.3.2. Sample of Short Data Call on Outbound

This is an outbound frame for short data call. A frame configuration will be shown in Figure 6.1-20.

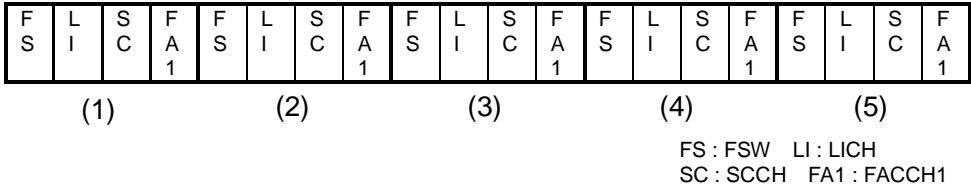

Frame	LICH	SCCH	FACCH1	FACCH1
(1)	FACCH1	INFO4 (Busy Repeater Message)	SDCALL_REQ(Header)	SDCALL_REQ(User Data) Data=3031323334353637
(2)	FACCH1	INFO4 (Free Repeater Message)	SDCALL_REQ(User Data) Data=38393A3B3C3D3E3F	SDCALL_REQ(User Data) Data=4041424344454647
(3)	FACCH1	INFO4 (Busy Repeater Message)	SDCALL_REQ(User Data) Data=48494A4B4C4D4E4F	SDCALL_REQ(User Data) Data=5051525354555657
(4)	FACCH1	INFO4 (Free Repeater Message)	SDCALL_REQ(User Data) Data=58595A5B5C5D5E5F	SDCALL_REQ(User Data) Data=60616263
(5)	FACCH1	INFO4(EOT)	TX_REL	TX_REL

Figure 6.1-20 Frame Structure for Short Data Call (Inbound)

Frame Data for Short Data Call (Outbound)

Frame1	
FSW	CDF59
LICH	FD77
SCCH	434CE7AE03D22A1
FACCH1	DAA4223826BA89810C432396B8360089E40C
FACCH1	6BAB1F9F38E87839D3542F360DF43460A48B
Frame2	
FSW	CDF59
LICH	FD77
SCCH	0BCC6033A2E8154
FACCH1	9FA3767D943A50DD7B678F21AF61664595A2
FACCH1	62869051E9C1C8C7087039A9CEB0BEBD5FE4
Frame3	
FSW	CDF59
LICH	FD77
SCCH	434CE7AE03D22A1
FACCH1	96AEE9B35513E4232103396E0C35E8966ACD
FACCH1	4F10497D687110E11B06A2FD64C679D3CAAE
Frame4	
FSW	CDF59
LICH	FD77
SCCH	0BCC6033A2E8154
FACCH1	BB18209FC4A33805B33502EAC6532BF6FB87
FACCH1	673081B219E104C9ED3104BB231001C36B5A
Frame5	
FSW	CDF59
LICH	FD77
SCCH	410CF3CD13CEE0
FACCH1	DAB4620C1EA389824AC1A2B6C8362089EC0A
FACCH1	58BC4086B4ABA10A62E9A2BCCAB400A16E20

Frame Data for Data Call (Inbound)

Frame1	
FSW	CDF59
LICH	FFDD
SCCH	434CE7AE03D22A1
UDCH2	9B04A2282EB2898009C022563866288BE70D008A028230208228AB212280E88A10A4A803
Frame2	
FSW	CDF59
LICH	FFDD
SCCH	434CE7AE03D22A1
UDCH2	A9032D0D8EE254B0FABD6FDC0F52164220A0 5C11D4789A910155BD56A6D9FC82435D51E3
Frame3	
FSW	CDF59
LICH	FFDD
SCCH	434CE7AE03D22A1
UDCH2	E035E28CBB408C40CD80D0D10D2387B790A2 21ECAF2C41D6CA21BF76782478C4804E8537
Frame4	
FSW	CDF59
LICH	FF7D
SCCH	410CF3CD13CEE0
FACCH3	DAA462081EAA8D800BC0A2F6A8363089EC08008A028230208228AB212280E88A10A4A803

6.1.2.4.2. Sample of Data Call on Outbound

This is an outbound frame for data call.
 A frame configuration will be shown in Figure 6.1-22.

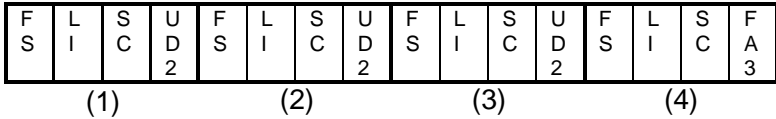

FS : FSW LI : LICH UD2 : UDCH2
 SC : SCCH FA3 : FACCH3

Frame	LICH	SCCH	UDCH2
			FACCH3
(1)	UDCH2	INFO4 (Busy Repeater Message)	DCALL(Header)
(2)	UDCH2	INFO4 (Free Repeater Message)	DCALL(User Data)
(3)	UDCH2	INFO4 (Busy Repeater Message)	DCALL(User Data)
(4)	FACCH3	INFO4(EOT)	TX_REL

Figure 6.1-22 Frame Structure for Data Call (Outbound)

Frame Data for Data Call (Outbound)

Frame1	
FSW	CDF59
LICH	FFD5
SCCH	434CE7AE03D22A1
UDCH2	9B04A2282EB2898009C022563866288BE70D008A028230208228AB212280E88A10A4A803
Frame2	
FSW	CDF59
LICH	FFD5
SCCH	0BCC6033A2E8154
UDCH2	A9032D0D8EE254B0FABD6FDC0F52164220A0 5C11D4789A910155BD56A6D9FC82435D51E3
Frame3	
FSW	CDF59
LICH	FFD5
SCCH	434CE7AE03D22A1
UDCH2	E035E28CBB408C40CD80D0D10D2387B790A2 21ECAF2C41D6CA21BF76782478C4804E8537
Frame4	
FSW	CDF59
LICH	FF75
SCCH	410CF3CD13CEE00
FACCH3	DAB4620C1EA389824AC1A2B6C8362089EC0A 008A028230208228AB212280E88A10A4A803

6.1.2.5. Frame Data for Status Call

6.1.2.5.1. Sample of Status Call on Inbound

This is an inbound frame for status call.

A frame configuration will be shown in Figure 6.1-23 and Figure 6.1-24.

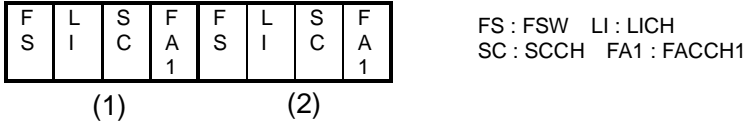

Frame	LICH	SCCH	FACCH1	FACCH1
(1)	FA1	INFO4	STAT_REQ Status = 1	STAT_REQ Status = 1
(2)	FA1	INFO4(EOT)	TX_REL	TX_REL

Figure 6.1-23 Frame Structure for Status Call using FACCH1 (Inbound)

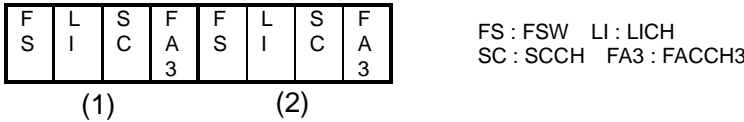

Frame	LICH	SCCH	FACCH3
(1)	FA3	INFO4	STAT_REQ Status = 1
(2)	FA3	INFO4(EOT)	TX_REL

Figure 6.1-24 Frame Structure for Status Call using FACCH3 (Inbound)

Frame Data for Status Call Using FACCH1 (Inbound)

Frame1	
FSW	CDF59
LICH	FD7F
SCCH	434CE7AE03D22A1
FACCH1	DB24E23806A28F830BC162B6485E2481E70F
FACCH1	592CC0B2ACAAA70B23E962BC4ADC04A96525
Frame2	
FSW	CDF59
LICH	FD7F
SCCH	410CF3CD13CEE00
FACCH1	DAA462081EAA8D800BC0A2F6A8363089EC08
FACCH1	58AC4082B4A2A50823E8A2FCAAB410A16E22

Frame Data for Status Call Using FACCH3 (Inbound)

Frame1	
FSW	CDF59
LICH	FF7D
SCCH	434CE7AE03D22A1
FACCH3	DB24E23806A28F830BC162B6485E2481E70F008A028230208228AB212280E88A10A4A803
Frame2	
FSW	CDF59
LICH	FF7D
SCCH	410CF3CD13CEE00
FACCH3	DAA462081EAA8D800BC0A2F6A8363089EC08008A028230208228AB212280E88A10A4A803

6.1.2.5.2. Sample of Status Call on Outbound

This is an outbound frame for status call.

A frame configuration will be shown in Figure 6.1-25 and Figure 6.1-26.

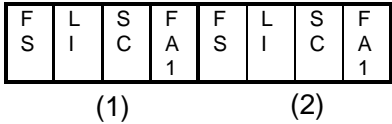

FS : FSW LI : LICH
 SC : SCCH FA1 : FACCH1

Frame	LICH	SCCH	FACCH1	FACCH1
(1)	FA1	INFO4 (Busy Repeater Message)	STAT_REQ Status = 1	STAT_REQ Status = 1
(2)	FA1	INFO4(EOT)	TX_REL	TX_REL

Figure 6.1-25 Frame Structure for Status Call using FACCH1 (Outbound)

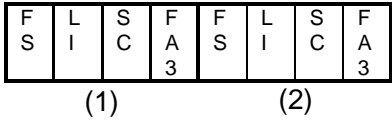

FS : FSW LI : LICH
 SC : SCCH FA3 : FACCH3

Frame	LICH	SCCH	FACCH3
(1)	FA3	INFO4 (Busy Repeater Message)	STAT_REQ Status = 1
(2)	FA3	INFO4(EOT)	TX_REL

Figure 6.1-26 Frame Structure for Status Call using FACCH3 (Outbound)

Frame Data for Status Call Using FACCH1 (Outbound)

Frame1	
FSW	CDF59
LICH	FD77
SCCH	434CE7AE03D22A1
FACCH1	DB24E23806A28F830BC162B6485E2481E70F
FACCH1	592CC0B2ACAAA70B23E962BC4ADC04A96525
Frame2	
FSW	CDF59
LICH	FD77
SCCH	410CF3CD13CEE0
FACCH1	DAB4620C1EA389824AC1A2B6C8362089EC0A
FACCH1	58BC4086B4ABA10A62E9A2BCCAB400A16E20

Frame Data for Status Call Using FACCH3 (Outbound)

Frame1	
FSW	CDF59
LICH	FF75
SCCH	434CE7AE03D22A1
FACCH3	DB24E23806A28F830BC162B6485E2481E70F008A028230208228AB212280E88A10A4A803
Frame2	
FSW	CDF59
LICH	FF75
SCCH	410CF3CD13CEE0
FACCH3	DAB4620C1EA389824AC1A2B6C8362089EC0A008A028230208228AB212280E88A10A4A803

6.1.2.6. Frame Data for Scramble Encrypted Voice Call

6.1.2.6.1. Sample of Scramble Encrypted Voice Call on Inbound

This is an inbound frame for scramble encrypted voice call. A frame configuration will be the same as shown in Figure 6.1-17.

Frame Data for Scramble Encrypted Voice Call (Inbound)

Frame1	
FSW	CDF59
LICH	FD7F
SCCH	434CE7AE03D22A1
FACCH1	9A8462A85E8ABF900A4120B7D89E6887F902
FACCH1	188C4022F4829718226920BDDA1C48AF7B28
Frame2	
FSW	CDF59
LICH	F5DD
SCCH	FEBA54C5A145A04
VCH	A8AED8CF46802ED6E6
VCH	E4AC757B2F70DE8CA2
VCH	A08AD01F8CC803C6C8
VCH	BF367D6BA70E11CE4F
Frame3	
FSW	CDF59
LICH	F5DD
SCCH	C74FF76E125A280
VCH	357F85387D1193AE4A
VCH	A4EE135D5B08388C2E
VCH	C1DA5DE3A8AC834F45
VCH	D5287D6DB642F5C252
Frame4	
FSW	CDF59
LICH	F5DD
SCCH	43EBD6A430C6E83
VCH	127B42DC1A1598C13A
VCH	9D590EAE70C0FEE644
VCH	E28CA665EE8C030A84
VCH	32AE3D29810B540DEA
Frame5	
FSW	CDF59
LICH	F5DD
SCCH	434CE7AE03D22A1
VCH	775DD21293BDCEE2A2
VCH	476A163BB88F0007F2
VCH	DE2D542BE2A2A1E127
VCH	2EAE3D2BD627BC9C66
Frame6	
FSW	CDF59
LICH	FD7F
SCCH	410CF3CD13CEE0
FACCH1	DAA462081EAA8D800BC0A2F6A8363089EC08
FACCH1	58AC4082B4A2A50823E8A2FCAAB410A16E22

6.1.2.6.2. Sample of Scramble Encrypted Voice Call on Outbound

This is an outbound frame for scramble encrypted voice call. A frame configuration will be the same as shown in Figure 6.1-18.

Frame Data for Scramble Encrypted Voice Call (Outbound)

Frame1	
FSW	CDF59
LICH	FD77
SCCH	434CE7AE03D22A1
FACCH1	9A8462A85E8ABF900A4120B7D89E6887F902
FACCH1	188C4022F4829718226920BDDA1C48AF7B28
Frame2	
FSW	CDF59
LICH	F5D5
SCCH	96A840E5C25547C
VCH	A8AED8CF46802ED6E6
VCH	E4AC757B2F70DE8CA2
VCH	A08AD01F8CC803C6C8
VCH	BF367D6BA70E11CE4F
Frame3	
FSW	CDF59
LICH	F5D5
SCCH	C74FF76E125A280
VCH	357F85387D1193AE4A
VCH	A4EE135D5B08388C2E
VCH	C1DA5DE3A8AC834F45
VCH	D5287D6DB642F5C252
Frame4	
FSW	CDF59
LICH	F5D5
SCCH	03EB42A55BDECB2
VCH	127B42DC1A1598C13A
VCH	9D590EAE70C0FEE644
VCH	E28CA665EE8C030A84
VCH	32AE3D29810B540DEA
Frame5	
FSW	CDF59
LICH	F5D5
SCCH	434CE7AE03D22A1
VCH	775DD21293BDCEE2A2
VCH	476A163BB88F0007F2
VCH	DE2D542BE2A2A1E127
VCH	2EAE3D2BD627BC9C66
Frame6	
FSW	CDF59
LICH	FD77
SCCH	410CF3CD13CEE0
FACCH1	DAB4620C1EA389824AC1A2B6C8362089EC0A
FACCH1	58BC4086B4ABA10A62E9A2BCCAB400A16E20

6.1.2.7. Frame Data for Scramble Encrypted Short Data Call**6.1.2.7.1. Sample of Scramble Encrypted Short Data Call on Inbound**

This is an inbound frame for scramble encrypted short data call. A frame configuration will be the same as shown in Figure 6.1-19.

Frame Data for Scramble Encrypted Short Data Call (Inbound)

Frame1	
FSW	CDF59
LICH	FD7F
SCCH	434CE7AE03D22A1
FACCH1	DA2462986692B9910C43A157D8A64085F404
FACCH1	682ADB1C3978B839D119ADA44C502C5D3CCF
Frame2	
FSW	CDF59
LICH	FD7F
SCCH	434CE7AE03D22A1
FACCH1	9F20BC9944DA0049147386E00FE28F811BF1
FACCH1	7801DDD6B9B19065604EA7EB0AA347FD17D8
Frame3	
FSW	CDF59
LICH	FD7F
SCCH	434CE7AE03D22A1
FACCH1	8020E29736EA086F1B1EBDA76A90E2F20A65
FACCH1	4D98481EE8F170C70C21B57FE4A449631688
Frame4	
FSW	CDF59
LICH	FD7F
SCCH	434CE7AE03D22A1
FACCH1	919664B8545A28A1EF13076F40B740D2E9BC
FACCH1	49B50930E9D97C51D62B083AC796DABFA30C
Frame5	
FSW	CDF59
LICH	FD7F
SCCH	410CF3CD13CEE0
FACCH1	DAA462081EAA8D800BC0A2F6A8363089EC08
FACCH1	58AC4082B4A2A50823E8A2FCAAB410A16E22

6.1.2.7.2. Sample of Scramble Encrypted Short Data Call on Outbound

This is an outbound frame for scramble encrypted short data call. A frame configuration will be the same as shown in Figure 6.1-20.

Frame Data for Scramble Encrypted Short Data Call (Outbound)

Frame1	
F5W	CDF59
LICH	FD77
SCCH	434CE7AE03D22A1
FACCH1	DA2462986692B9910C43A157D8A64085F404
FACCH1	682ADB1C3978B839D119ADA44C502C5D3CCF
Frame2	
F5W	CDF59
LICH	FD77
SCCH	0BCC6033A2E8154
FACCH1	9F20BC9944DA0049147386E00FE28F811BF1
FACCH1	7801DDD6B9B19065604EA7EB0AA347FD17D8
Frame3	
F5W	CDF59
LICH	FD77
SCCH	434CE7AE03D22A1
FACCH1	8020E29736EA086F1B1EBDA76A90E2F20A65
FACCH1	4D98481EE8F170C70C21B57FE4A449631688
Frame4	
F5W	CDF59
LICH	FD77
SCCH	0BCC6033A2E8154
FACCH1	919664B8545A28A1EF13076F40B740D2E9BC
FACCH1	49B50930E9D97C51D62B083AC796DABFA30C
Frame5	
F5W	CDF59
LICH	FD77
SCCH	410CF3CD13CEE80
FACCH1	DAB4620C1EA389824AC1A2B6C8362089EC0A
FACCH1	58BC4086B4ABA10A62E9A2BCCAB400A16E20

6.1.2.8. Frame Data for Scramble Encrypted Data Call

6.1.2.8.1. Sample of Scramble Encrypted Data Call on Inbound

This is an inbound frame for scramble encrypted data call. A frame configuration will be the same as shown in Figure 6.1-21.

Frame Data for Scramble Encrypted Data Call (Inbound)

Frame1	
FSW	CDF59
LICH	FFDD
SCCH	434CE7AE03D22A1
UDCH2	9B84E2886E9AB99009C0A09758F66887F705 008A028230208228AB212280E88A10A4A803
Frame2	
FSW	CDF59
LICH	FFDD
SCCH	434CE7AE03D22A1
UDCH2	AA82E98E8F7294B0F8F0ED4E4EF60E7FB8E4 758317D9FD6298451D57A8B22FC1CA13085F
Frame3	
FSW	CDF59
LICH	FFDD
SCCH	434CE7AE03D22A1
UDCH2	DCA9E74CD88008D2B0A84C57E84266C71400 111DD71F2E4184446D9A5AEC2CFC53199C71
Frame4	
FSW	CDF59
LICH	FF7D
SCCH	410CF3CD13CEE80
UDCH2	DAA462081EAA8D800BC0A2F6A8363089EC08 008A028230208228AB212280E88A10A4A803

6.1.2.8.2. Sample of Scramble Encrypted Data Call on Outbound

This is an outbound frame for scramble encrypted data call. A frame configuration will be the same as shown in Figure 6.1-22.

Frame Data for Scramble Encrypted Data Call (Outbound)

Frame1	
FSW	CDF59
LICH	FFD5
SCCH	434CE7AE03D22A1
UDCH2	9B84E2886E9AB99009C0A09758F66887F705 008A028230208228AB212280E88A10A4A803
Frame2	
FSW	CDF59
LICH	FFD5
SCCH	0BCC6033A2E8154
UDCH2	AA82E98E8F7294B0F8F0ED4E4EF60E7FB8E4 758317D9FD6298451D57A8B22FC1CA13085F
Frame3	
FSW	CDF59
LICH	FFD5
SCCH	434CE7AE03D22A1
UDCH2	DCA9E74CD88008D2B0A84C57E84266C71400 111DD71F2E4184446D9A5AEC2CFC53199C71
Frame4	
FSW	CDF59
LICH	FF75
SCCH	410CF3CD13CEE80
UDCH2	DAB4620C1EA389824AC1A2B6C8362089EC0A 008A028230208228AB212280E88A10A4A803

7. Revision History

Version	Date	Revised Contents
1.0	2012.11.2	Version 1.0 release