



**QUANTAR<sup>®</sup>/QUANTRO<sup>®</sup>**

# **RADIO SERVICE SOFTWARE INSTRUCTION MANUAL**



## Computer Software Copyrights

The Motorola products described in this document include a copyrighted Motorola computer program. Laws in the United States and other countries, as well as International Treaties, preserve for Motorola the exclusive rights for Motorola's copyrighted computer programs, including the exclusive right to copy, reproduce, distribute, or otherwise transfer said computer program(s). Accordingly, the copyrighted Motorola computer programs contained in this document may not be copied, decompiled, reverse engineered, or reproduced in any manner and on or within any media without the express written permission of Motorola. Furthermore, the purchase of Motorola products shall not be deemed to grant either directly or by implication, estoppel, or otherwise, any license under the copyrights, patents, or patent applications of Motorola, except for the normal non-exclusive, royalty-free license to use that arises by operation of law in the sale of a product.

## Document Copyrights

© Motorola Solutions, Inc. All rights reserved.

No duplication or distribution of this document or any portion thereof shall take place without the express written permission of Motorola. No part of this document may be reproduced, distributed, or transmitted in any form or by any means, electronic or mechanical, for any purpose without the express written permission of Motorola.

To order additional copies of this document contact your Motorola sales representative.

## Disclaimer

The information in this document is carefully examined, and is believed to be entirely reliable. However, no responsibility is assumed for inaccuracies. Furthermore, Motorola reserves the right to make changes to any products herein to improve readability, function, or design. Motorola does not assume any liability arising out of the applications or use of any product or circuit described herein; neither does it cover any license under its patent rights nor the rights of others.

## Trademark Information

The following are registered trademarks of Motorola Solutions, Inc.: Motorola, the Motorola logo, ASTRO, ASTRO-TAC, EMBASSY, FullVision, INTELLIREPEATER, QUANTAR, QUANTRO, and SMARTZONE.

The following are Motorola trademarks: CENTRACOM Elite, CENTRACOM Series, CENTRACOM Gold Series, MOSCAD, SECURENET, and Wireless Network Gateway.

HP, HP-UX, OpenView, Vectra, and Hewlett Packard are registered trademarks of Hewlett-Packard Corporation.

UNIX is a registered trademark of The Open Group in the United States and other countries.

Any other brand or product names are trademarks or registered trademarks of their respective holders.

## WARRANTY

### Limited Software Warranty

For the first ninety (90) days following its initial shipment, Motorola warrants that when properly used, its software will be free from reproducible defects that cause a material variance from its published specification. However, Motorola does not warrant that program operation will be uninterrupted or error-free, that each defect will be corrected, or that any program will meet Licensee's particular requirements.

This warranty does not cover an item of Software (i) used in other than its normal and customary manner; (ii) subjected to misuse; or (iii) subjected to modifications by Licensee or by any party other than Motorola without the prior written consent of Motorola.

### Limited Media Warranty

For the first ninety (90) days following its initial shipment, Motorola warrants that the media carrying the software will be free from defects that damage the performance of the software. Motorola will replace any damaged media free of charge during the warranty period. Warranted media is limited to that which is used to transport the software (such as floppy disks and authorization key). PROMs that may store the software in equipment are not covered under this warranty.

### Limitation of Liability

Motorola's total liability and Licensee's sole remedy for any warranted software shall be limited to, at Motorola's option, software replacement or the payment of Licensee's actual damages, not to exceed the total licensed charge paid by Licensee to Motorola for the item of software that caused the damage.

The warranties set forth above extend only to the first licensee. Subsequent transferees accept these programs "as is" and without warranties of any kind. **This warranty is given in lieu of all other warranties, express or implied, including, without limitation, the warranties of merchantability and fitness for a particular purpose.**

In no event shall Motorola be liable for special, incidental, or consequential damages (including, without limitation, loss of use, time or data, inconvenience, commercial loss, and lost profits or savings) to the full extent that such may be disclaimed by law even if Motorola has been advised of the possibility of such damage against licensee by any other party.

### Repair of Defects

The classification of defects in Motorola-supplied software shall be the responsibility of Motorola. Remedy of defects is at the sole discretion of Motorola. If Motorola agrees to remedy a software defect, the new software will be warranted until the end of the original limited warranty period.

Replacement of any software defect shall constitute Motorola supplying the Licensee with the appropriate software media and authorization key. Field installation and configuration are not included. Field software updates/upgrades and new enhancement option software will be warranted for ninety (90) days from the date of initial shipment.

All warranty service will be performed at service locations designated by Motorola. Travel and associated expenses of the Licensee or such expenses incurred by Motorola for visits to Licensee's location by Motorola personnel are not covered by this warranty.

# Table of Contents

## Chapter 1: Introduction

Intended User Profile .....	1-1
Organization of this Guide .....	1-2
Related Manuals .....	1-3

## Chapter 2: RSS Overview

Summary of Features .....	2-1
User Interface Description .....	2-2
PC Requirements .....	2-4
Installing the RSS Software .....	2-4
Removing a Previous RSS Version .....	2-8
Connecting the PC to the Device RSS Port .....	2-11
Working with the RSS Program .....	2-12
Launching the RSS Program .....	2-12
Exiting the RSS Program .....	2-13
Reading the Device Codeplug .....	2-14
Navigating Through the RSS Screens .....	2-17
Writing Codeplug Data to the Device .....	2-20
Obtaining Codeplug Size .....	2-21
File Maintenance .....	2-21
Saving Configuration Data to an Archive File .....	2-22
Opening an Archive Codeplug File .....	2-24

## Chapter 3: Optimization

Required Test Equipment .....	3-2
Verifying the Device's Configuration Data .....	3-3
Device Type Programming Overview .....	3-5
Programming the IP Address .....	3-6
Programming the MAC Address .....	3-7
Setting the Device's Date and Time .....	3-8
Programming Wireline Configuration Data .....	3-9
Programming the Access Code Table Data For Conventional Systems .....	3-13
Programming the Access Code Table Data for 6809 Trunking Systems .....	3-15
Programming the Multi-Coded Squelch Table Screen .....	3-16

Saving User Information . . . . .	3-17
Adding New Users . . . . .	3-17
Modifying an Existing User . . . . .	3-18
Deleting an Existing User . . . . .	3-19
Programming the Channel Information Screen . . . . .	3-20
Programming the TRC Commands Data . . . . .	3-25
Programming DC Remote Command Data . . . . .	3-27
Programming the RF Configuration Data Screen . . . . .	3-29
Programming the 6809 Trunking Interface Data . . . . .	3-31
Programming the Scan List Configuration Data . . . . .	3-32
Programming the IntelliRepeater . . . . .	3-35
Programming the Site Frequency Parameters . . . . .	3-36
Programming the Site General Parameters . . . . .	3-37
Programming the Site Timer Screen . . . . .	3-39
Programming Radio Modulation Partition Screens . . . . .	3-40
Programming Full/Sub Band Partition Screens . . . . .	3-41
Programming Repeater Summary Screen . . . . .	3-41
Programming the Repeater Information Screen . . . . .	3-42
Programming RF Configuration . . . . .	3-44
Programming the Codeplug Data into a Conventional or 6809 Station or ASTRO-TAC Comparator . . . . .	3-46
Programming the Codeplug Data into an IntelliRepeater Station Installed in a SmartZone 2.0.3 or 2.7E System . . . . .	3-48
Programming the Codeplug Data into an IntelliRepeater Station Installed in a SmartZone 3.0, 3.5, or 4.1 System . . . . .	3-51
Performing Station Alignment . . . . .	3-54
Required Test Equipment . . . . .	3-55
RX and TX Wireline Alignment . . . . .	3-55
Procedure A: Rx Wireline Alignment Procedure . . . . .	3-57
Procedure B: Rx Wireline Equalization Alignment Procedure . . . . .	3-59
Procedure C: Status Tone Level Alignment Procedure . . . . .	3-63
Procedure D: Optional Hi Boost Fine Tuning Procedure . . . . .	3-64
Procedure E: Aligning TX Wireline Procedure . . . . .	3-66
Procedure F: Aligning ASTRO Link Management Tone Procedure . . . . .	3-68
Aligning Radio Signal Strength Indicator (RSSI) . . . . .	3-68
Aligning Squelch Adjust Procedure . . . . .	3-71
Equalizing Batteries . . . . .	3-73
For QUANTAR Stations: . . . . .	3-73
For Quantro Stations: . . . . .	3-75
Calibrating Reference Oscillator Procedure . . . . .	3-75
Reference Oscillator Calibration: Internal Reference Oscillator - Manual Procedure . . . . .	3-75
Reference Oscillator Calibration: Internal Reference Oscillator - Auto-Net Procedure . . . . .	3-77
Reference Oscillator Calibration: External Reference Oscillator . . . . .	3-78
Reference Oscillator Calibration: Internal Ultra High Stability Oscillator (UHSO) . . . . .	3-78



Setting ASTRO Tx Align and Test Procedure . . . . .	3-82
Generating ASTRO Test Patterns . . . . .	3-85
TDATA Calibration (6809 Trunking Station Only) . . . . .	3-88
ASTRO Bit Error Rate Reports . . . . .	3-90
Post-Optimization Checkout . . . . .	3-93

## Chapter 4: Optimizing the ASTRO-TAC Comparator

Verifying the Comparator's Configuration Data . . . . .	4-2
Programming the Comparator . . . . .	4-3
Programming the Hardware Configuration Screen . . . . .	4-3
Programming the Conventional System Screen . . . . .	4-5
Programming the Smartzone System Screen . . . . .	4-6
Programming the Analog Voting Screen . . . . .	4-7
Programming the Port Control Screen . . . . .	4-8
Performing Comparator Alignment . . . . .	4-9
Equalizing Batteries . . . . .	4-10
Reference Oscillator Calibration Procedures . . . . .	4-10
Internal Reference Oscillator – Auto-Net Procedure . . . . .	4-11
External Reference Oscillator Calibration . . . . .	4-11

## Chapter 5: Diagnostics and Status

Station/Comparator Status Messages . . . . .	5-1
Station Metering Screens . . . . .	5-2
Station/Comparator Status Report Screen . . . . .	5-3
Station/Comparator-Generated Status Messages . . . . .	5-5
Station Status Panel Screen . . . . .	5-26
Comparator Status Panel Screen . . . . .	5-28
Station/Comparator Software Version . . . . .	5-30
Setting Date and Time . . . . .	5-30
Codeplug Reports . . . . .	5-31
Printing a Codeplug Report . . . . .	5-31
Saving the Codeplug Report to a File . . . . .	5-32
Remote Station Disabling/Enabling . . . . .	5-33
ASTRO-TAC Diagnostics . . . . .	5-34

## Chapter 6: Performing Post Repair Alignment

Overview of Alignment Routines . . . . .	6-1
Test Equipment for Post-Repair Alignment Procedures . . . . .	6-4
Aligning Power Output Procedure . . . . .	6-4
Aligning Power Output Procedure for a Quantro 350W VHF Station . . . . .	6-7
Aligning Tx Deviation Gain Adjust Procedure, 350W VHF Stations . . . . .	6-11
Aligning Reference Modulation Compensation Procedure . . . . .	6-14

## Chapter 7: Version Compatibility and Upgrades

Prior to Release R07.02.02 .....	7-1
Beginning with Release R7.02.02 .....	7-2
RSS Program Version and Station Firmware Relationship .....	7-2
RSS Program Versions Compatibility .....	7-16
Retrieving Station Software Versions .....	7-17
Retrieving Comparator Software Versions and Backplane ID .....	7-18
Performing Upgrades .....	7-19
Upgrading the Station's Codeplug .....	7-19
Upgrading an Archived Codeplug File .....	7-21
Features and System Capabilities .....	7-22

## Chapter 8: Password Protection

How Password Protection Works .....	8-1
Password Time-out .....	8-1
Activating Password Protection .....	8-1
Special Password Protection Features .....	8-2
Creating the Station's Password .....	8-2
Changing Station Password .....	8-3
Erasing Station Password (Local Access) .....	8-4
Erasing Station Password (Remote Access) .....	8-5
Bypassing the Station Password .....	8-6

## Chapter 9: Remote Dial-Up

Modem Requirements .....	9-2
Station Modem Configuration .....	9-2
PC Modem Configuration .....	9-3

## Chapter 10: WildCard Operation

Station Auxiliary Inputs .....	10-2
Programming the WildCard Input Screen .....	10-2
Station Auxiliary Outputs .....	10-4
Programming the Wildcard Output Screen .....	10-5
State/Action Tables .....	10-6
How State/Action Tables Operate .....	10-7
Programming the Wildcard State Screen .....	10-8

## Chapter 11: Software Downloading

Prerequisites .....	11-2
Preparing PC for Software Download Communications .....	11-3
Adding a Null Modem Device in Microsoft Windows XP Professional .....	11-3
Adding a Null Modem in Windows XP Professional .....	11-3

Adding a SLIP Connection in Windows XP Professional for a Null Modem Connection .....	11-8
Adding a Dial-Up Modem Device in Microsoft Windows XP Professional.....	11-15
Adding a Dial-Up Modem in Windows XP Professional.....	11-15
Adding a SLIP Connection in Windows XP Professional for a Dial-Up Modem Connection .....	11-17
Adding a Virtual Network Adapter Driver in Microsoft Windows Vista and Windows 7.....	11-25
Adding a Virtual Network Adapter Driver in Windows Vista and Windows 7.....	11-25
RSS SLIP Connection Naming Convention.....	11-33
Naming Convention for Null Modem install.....	11-34
Naming Convention for Dial-Up Modem install.....	11-34
Connecting to the Device.....	11-35
Serial (Direct) Connection.....	11-35
Ethernet Connections.....	11-36
Remote Dial-Up Connections.....	11-38
Zone Controller Link Connection.....	11-38
Loading Station Software Files onto the PC.....	11-41
Downloading Software to Station/Receiver Memory - Conventional and 6809 Controller Systems or ASTRO-TAC Comparator Memory.....	11-41
Downloading Software to IntelliRepeater Memory.....	11-45

## **Appendix A: PL/DPL Codes**

## **Appendix B: dBm to Microvolts Conversion**

## **Appendix C: Glossary**

## **Appendix D: Acronyms**



# List of Figures

Figure 2-1	RSS Window Overview .....	2-2
Figure 2-2	RSS Toolbar Buttons .....	2-3
Figure 2-3	RSS Menus .....	2-3
Figure 2-4	Null-Modem Cable Wiring Diagram.....	2-11
Figure 2-5	RSS Cable Connections .....	2-12
Figure 2-6	Connection Screen Window .....	2-15
Figure 2-7	RSS Information and Function Screens.....	2-20
Figure 2-8	Codeplug Size Information Window .....	2-21
Figure 3-1	Accessing the IP Address Field.....	3-6
Figure 3-2	Accessing the MAC Address Field .....	3-7
Figure 3-3	Set Date and Time Screen .....	3-8
Figure 3-4	Wireline Configuration Screen Examples – Analog Only Station Type .....	3-9
Figure 3-5	Wireline Configuration Screen Tab Examples – ASTRO Capable or ASTRO CAI Capable Station Type .....	3-10
Figure 3-6	Access Code Table Screens .....	3-13
Figure 3-7	Access Code Table Screens .....	3-15
Figure 3-8	Multi-Coded Squelch Table Screen.....	3-16
Figure 3-9	Save Report Button to Save MCS Data .....	3-17
Figure 3-10	Channel Configuration Screen .....	3-20
Figure 3-11	Advanced Channel Information Screen.....	3-21
Figure 3-12	TRC Command Table Screen .....	3-25
Figure 3-13	DC Command Table Screen .....	3-28
Figure 3-14	RF Configuration Screens .....	3-29
Figure 3-15	6809 Trunking Interface Screen .....	3-31
Figure 3-16	Scan List Configuration Screen.....	3-33
Figure 3-17	IntelliRepeater Specific Configuration Screens.....	3-35
Figure 3-18	Site Frequency Screen.....	3-36
Figure 3-19	Site General Screen .....	3-37
Figure 3-20	Site Timer Screen.....	3-39
Figure 3-21	Radio Modulation Partition Screen.....	3-40
Figure 3-22	Full/Sub Band Partition and Radio Modulation Partition Screen .....	3-41
Figure 3-23	Repeater Summary Screen.....	3-41
Figure 3-24	Repeater Information Screen - Basic Tab .....	3-42
Figure 3-25	Repeater Information Screen - Advanced Tab.....	3-42
Figure 3-26	RF Configuration Screen - Conventional Stations.....	3-45
Figure 3-27	RF Configuration Screen - IntelliRepeater and 6809 Trunking Stations .....	3-45
Figure 3-28	TX Wireline Alignment Setup .....	3-67

Figure 3-29	RSSI Alignment Test Setup .....	3-69
Figure 3-30	Squelch Adjust Alignment Setup.....	3-71
Figure 4-1	Comparator Configuration Screen .....	4-3
Figure 4-2	Hardware Configuration Screen.....	4-4
Figure 4-3	Conventional System Screen.....	4-5
Figure 4-4	Smartzone System Screen .....	4-6
Figure 4-5	Analog Voting Screen .....	4-7
Figure 4-6	Port Control Screen.....	4-8
Figure 5-1	Station Metering Screen Example.....	5-3
Figure 5-2	Station Status Report Screen Example.....	5-4
Figure 5-3	Comparator Status Report Screen Example.....	5-5
Figure 5-4	Station Status Panel Screen Example .....	5-27
Figure 5-5	Status Panel Screen Example: Primary Comparator in an Expanded Configuration.....	5-28
Figure 5-6	Status Panel Screen Example: Standard Comparator.....	5-29
Figure 5-7	Station and Comparator Version Screens.....	5-30
Figure 5-8	Example of a Saved Codeplug Report.....	5-33
Figure 6-1	Reference Oscillator Alignment Screen .....	6-2
Figure 6-2	Power Output Alignment Setup.....	6-5
Figure 6-3	Power Output Alignment Setup for Quantro 350W Stations .....	6-8
Figure 6-4	Tx Deviation Gain Adjust Alignment Setup .....	6-12
Figure 6-5	Reference Modulation Compensation Alignment Setup .....	6-14
Figure 6-6	Waveform Examples .....	6-16
Figure 7-1	Release R1.00 Features and System Capabilities – Conventional.....	7-22
Figure 7-2	Release R2.00 Features and System Capabilities - Conventional .....	7-23
Figure 7-3	Release R3.00 / R3.01 Features and System Capabilities - Conventional.....	7-24
Figure 7-4	Release R4.00 Features and System Capabilities - Conventional .....	7-25
Figure 7-5	Release R5.00 Features and System Capabilities - Conventional .....	7-26
Figure 7-6	Release R6.00 Features and System Capabilities - Conventional .....	7-27
Figure 7-7	Release R7.00 Features and System Capabilities - Conventional .....	7-28
Figure 7-8	Release R07.02.02 Features and System Capabilities - Conventional .....	7-29
Figure 7-9	Release R08.00.00-R08.03.00 Features and System Capabilities - Conventional .....	7-30
Figure 7-10	Release R09.00.00 Features and System Capabilities - Conventional .....	7-31
Figure 7-11	Release R09.02.01 Features and System Capabilities - Conventional .....	7-32
Figure 7-12	Release R09.03.00 Features and System Capabilities - Conventional .....	7-33
Figure 7-13	Release R09.05.00/R09.06.00 Features and System Capabilities - Conventional .....	7-34
Figure 7-14	Release R09.07.00/R10.00.00 through R10.08.00, R10.11.00, R10.12.00 Features and System Capabilities - Conventional .....	7-35
Figure 7-15	Release R12.01.00 through R12.03.00 Features and System Capabilities - Conventional .....	7-36
Figure 7-16	Release R13.00.00 through R13.02.00 Features and System Capabilities - Conventional .....	7-37
Figure 7-17	Release R14.0.00 Features and System Capabilities - Conventional .....	7-38
Figure 7-18	Release R2.00 Features and System Capabilities - 6809 Trunking .....	7-39

Figure 7-19	Release R3.00 / R3.01 Features and System Capabilities - 6809 Trunking ...	7-40
Figure 7-20	Release R4.00 Features and System Capabilities - 6809 Trunking .....	7-41
Figure 7-21	Release R5.00 Features and System Capabilities - 6809 Trunking.....	7-42
Figure 7-22	Release R6.00 Features and System Capabilities - 6809 Trunking.....	7-43
Figure 7-23	Release R7.00 Features and System Capabilities - 6809 Trunking.....	7-44
Figure 7-24	Release R07.02.02 Features and System Capabilities - 6809 Trunking.....	7-45
Figure 7-25	Release R09.00.00 Features and System Capabilities - 6809 Trunking.....	7-46
Figure 7-26	Release R09.02.01 Features and System Capabilities - 6809 Trunking.....	7-47
Figure 7-27	Release R09.03.00 Features and System Capabilities - 6809 Trunking.....	7-48
Figure 7-28	Release R09.05.00/R09.06.00/R09.07.00/R10.00.00 through R10.08.00, R10.11.00, R10.12.00 Features and System Capabilities - 6809 Trunking ....	7-49
Figure 7-29	Release R12.01.00 through R12.03.00 Features and System Capabilities - 6809 Trunking .....	7-50
Figure 7-30	Release R13.00.00 through R14.00.00 Features and System Capabilities - 6809 Trunking .....	7-51
Figure 7-31	Release SZ2.0 Features and System Capabilities - IntelliRepeater Trunking	7-52
Figure 7-32	Release SZ2.3 Features and System Capabilities - IntelliRepeater Trunking	7-52
Figure 7-33	Release SZ2.7/2.7E Features and System Capabilities - IntelliRepeater Trunking .....	7-52
Figure 7-34	Release 12.00.00 through 12.02.00 Features and System Capabilities - IntelliRepeater SZ2.0.3 Trunking.....	7-53
Figure 7-35	Release 12.00.00 through 12.02.00 Features and System Capabilities - IntelliRepeater SmartZone 3.0/3.5/4.1 Trunking .....	7-53
Figure 7-36	Release 13.00.00 through 13.02.00 Features and System Capabilities - IntelliRepeater SmartZone 3.0/3.5/4.1 Trunking .....	7-54
Figure 7-37	Release 14.00.00 Features and System Capabilities - IntelliRepeater SmartZone 3.0/3.5/4.1Trunking .....	7-54
Figure 7-38	Release 14.02.00 Features and System Capabilities - IntelliRepeater SmartZone 3.0/3.5/4.1Trunking.....	7-54
Figure 7-39	Release 14.00.00 Features and System Capabilities - IntelliRepeater SmartZone 2.0.3 Trunking.....	7-55
Figure 9-1	Remote Dial-Up Connection.....	9-1
Figure 10-1	WildCard Input Screen - Enhanced Shown.....	10-3
Figure 10-2	WildCard Output Screen - Enhanced Shown .....	10-5
Figure 10-3	WildCard State Screen.....	10-8
Figure 11-1	Serial Connection for Software Download.....	11-35
Figure 11-2	Ethernet Connection to a Single Station .....	11-36
Figure 11-3	Ethernet Connection to IntelliRepeater Ethernet Network.....	11-36
Figure 11-4	Remote Dial-Up Connection.....	11-37
Figure 11-5	Zone Controller Link Connection.....	11-39
Figure 11-6	Adapter for Connecting between PC and Zone Controller Link .....	11-39

**THIS PAGE INTENTIONALLY LEFT BLANK.**



# List of Tables

Table 3-1	Site Number Ranges .....	3-4
Table 3-2	Device Types and Applicable Screens .....	3-5
Table 3-3	Wireline Tab Parameters.....	3-10
Table 3-4	Tone Remote Control Tab Parameters .....	3-11
Table 3-5	ASTRO Tab Parameters .....	3-12
Table 3-6	Access Code Table Field Definitions.....	3-14
Table 3-7	Access Code Table Screen Parameters .....	3-15
Table 3-8	Channel Configuration Field Definitions .....	3-21
Table 3-9	TRC Commands.....	3-26
Table 3-10	RF Configuration Data Fields.....	3-29
Table 3-11	6809 Trunking Interface Screen Data Fields.....	3-31
Table 3-12	Scan List Configuration Data Fields .....	3-33
Table 3-13	IntelliRepeater Screen Fields .....	3-35
Table 3-14	Site Frequency Screen Data Fields.....	3-37
Table 3-15	Site General Screen Data Fields.....	3-38
Table 3-16	Site Timer Screen Data Fields .....	3-39
Table 3-17	Radio Modulation Partition Screen Data Fields.....	3-40
Table 3-18	Full/Sub Band Partition Screen Data Fields.....	3-41
Table 3-19	Repeater Information Screen Data Fields .....	3-43
Table 3-20	RF Configuration Data Fields.....	3-46
Table 3-21	RX/TX Wireline Alignment Matrix .....	3-56
Table 3-22	RX/TX Wireline Equalization Matrix .....	3-56
Table 3-23	RX Wireline ASTRO Link Management Tone Alignment Matrix .....	3-56
Table 4-1	Hardware Configuration Screen Data Fields.....	4-4
Table 4-2	Conventional System Screen Data Fields.....	4-5
Table 4-3	Smartzone System Screen Data Fields .....	4-6
Table 4-4	Analog Voting Screen Data Fields .....	4-7
Table 4-5	Port Control Screen Data Fields.....	4-8
Table 5-1	Station / Comparator-Generated Status Messages .....	5-6
Table 5-2	Status Panel Screen Buttons .....	5-27
Table 5-3	Comparator Status Panel Screen Buttons .....	5-29
Table 6-1	Alignment Procedures .....	6-2
Table 7-1	TRN7475 <sup>1</sup> and TRN7667 <sup>1</sup> Station Control Boards RSS Compatibility .....	7-3
Table 7-2	TTN4094 <sup>1</sup> and TRN7900 <sup>1</sup> Station Control Boards RSS Compatibility.....	7-4
Table 7-3	CLN6960, CLN6961, CLN6873, and CLN7060 Station Control Boards (with Software Download Capability; Non-IntelliRepeater 5.0 Stations) RSS Compatibility .....	7-7

Table 7-4	Factory Shipped Upgrade Kit <sup>1</sup> RSS Compatibility (for stations without Software Download Capability) .....	7-12
Table 7-5	CLN6960 Station Control Boards (IntelliRepeater 5.0 Stations) RSS Version Compatibility .....	7-14
Table 7-6	CLN7462 Station Control Boards (“Limited” QUANTAR) RSS Version Compatibility.....	7-15
Table 9-1	RSS PC Modem Configuration Data Fields .....	9-5
Table 10-1	Wildcard Input Screen Data Fields.....	10-3
Table 10-2	Wildcard Output Screen Data Fields.....	10-5
Table 10-3	Wildcard State/Action Screen Data Fields .....	10-9
Table 11-1	Zone Controller Link Connection Scenarios.....	11-38
Table A-1	Tone Private-Line (PL) Codes.....	A-1
Table A-2	Digital Private-Line (DPL) Codes .....	A-2
Table B-1	dBm to Microvolts Conversion .....	B-1

# Introduction

---

The base station products Radio Service Software (RSS) program described in this guide provides service and maintenance personnel the ability to customize, align, and troubleshoot a variety of Motorola base station products and ancillary equipment.

The RSS is intended for use with the following products:

- QUANTAR, Quantro stations, and ASTRO-TAC receivers
- DSS-III data station
- QUANTAR data base station (DBS)
- ASTRO-TAC comparator

The Graphical User Interface (GUI) and context sensitive help simplify setting up the stations for operation in your system. To gain the full benefit of many features and capabilities offered by the RSS program, please read this guide and keep it handy as a reference for day to day operations.



## NOTE

The figures provided in this guide are examples only. The screens you see may be different depending on your Microsoft® Windows operating system.

# Intended User Profile

---

The information presented in this guide is intended for use by qualified communications technicians and maintenance personnel to program, troubleshoot, and align QUANTAR and Quantro stations and ancillary equipment. It is assumed that the user is:

- Familiar with general communications equipment operation, alignment, and maintenance
- Proficient in the use of alignment and servicing test equipment, such as an oscilloscope, digital voltmeter (DVM), and the Motorola R2001 (or equivalent) communications analyzer
- Experienced using computers running Microsoft Windows XP, Windows Vista, Windows 7 or Windows Server 2008 R2 operating systems (OSs) and familiar with Windows applications and operations.

Performing tasks such as copying disks and executing programs, while described in this guide, would be facilitated by a general knowledge of Microsoft Windows XP, Windows Vista, Windows 7 or Windows Server 2008 R2. Refer to your PC and OS manuals for information relating to installation, operation, and maintenance of your computer and OS.

First time users should read Chapter 1 and Chapter 2 before using the RSS program to perform actual tasks. Chapter 2 serves as a basic tutorial, guiding you through loading and launching the RSS program and allowing you to investigate the various GUI screens.

Users experienced in using RSS can refer to the appropriate chapter to perform a specific task.

## Organization of this Guide

---

This guide is written in a task-oriented format, providing you with the most efficient and productive means of using the RSS program in real world applications. The guide is divided into logical chapters, each one concentrating on a particular general topic. This method of organization allows you to quickly find the information you need to perform a certain task, without having to read the entire guide or flip back and forth between chapters.

The content of each chapter is summarized below.

- Chapter 1, “Introduction,” provides general information regarding this guide, including a profile of the intended audience and typographic conventions used throughout this guide.
- Chapter 2, “RSS Overview,” provides step-by-step instructions for loading the RSS software, launching the program, common practices such as saving data, and navigating through the GUI.
- Chapter 3, “Optimization,” provides step-by-step instructions for using the RSS program to optimize a newly installed station and includes codeplug programming and alignment tasks required at time of installation of station equipment.
- Chapter 4, “Optimizing the ASTRO-TAC Comparator,” provides step-by-step instructions for using the RSS program to program a newly installed ASTRO-TAC comparator.
- Chapter 5, “Diagnostics and Status,” describes how to use the diagnostics capabilities of the RSS program, also describes how to read and interpret the status report log, how to use the front panel display, and how to use the digital meeting screens.
- Chapter 6, “Performing Post Repair Alignment,” provides step-by-step procedures for performing station alignment routines.
- Chapter 7, “Version Compatibility and Upgrades,” provides information regarding RSS version compatibility issues and instructions for performing RSS and station upgrades.
- Chapter 8, “Password Protection,” describes the use of the station password protection feature.
- Chapter 9, “Remote Dial-Up,” describes how to make a dial-up connection, through a modem, to the station. This allows the RSS to be used remotely.
- Chapter 10, “Wildcard Operation,” describes how to use the wildcard option feature.

- Chapter 11, “Software Downloading,” describes how to download station software to FLASH memory on the station control board.
- Appendix A, “PL/DPL Codes,” provides the PL/DPL codes.
- Appendix B, “dBm to Microvolts Conversion,” provides a table of dBm to microvolt conversions.
- Appendix C, “Glossary,” provides a glossary of terms.
- Appendix D, “Acronyms,” provides a listing of acronyms and abbreviations.

## Related Manuals

---

The following manuals may be required to supplement the information contained in this guide. The Functional Manuals provide additional servicing and troubleshooting information for use by technicians when optimizing or servicing QUANTAR or Quantro station equipment.

- Motorola *QUANTAR Functional Manual* (VHF, UHF, 800 MHz, 900 MHz) 68P81095E05
- Motorola *QUANTAR Data Base Station Functional Manual* (UHF, 800 MHz, 900 MHz) 68P81096E05
- Motorola *Quantro Functional Manual* (VHF, UHF, 800 MHz, 900 MHz) 68P80800E95
- Motorola *QUANTAR Satellite Receiver Functional Manual* 68P81087E25
- Motorola *ASTRO-TAC Receiver Functional Manual* 68P81094E85
- Motorola *ASTRO-TAC 3000 Digital Voting Comparator Functional Manual* 68P810098E20
- Microsoft® software user manuals for Windows XP, Windows Vista or Windows Server 2008 R2 operating systems (refer to Microsoft® system documentation for manual titles)
- Computer owner's manual

**THIS PAGE INTENTIONALLY LEFT BLANK.**

## RSS Overview

---

The model RVN5002 (ver 14.00.00 and later) RSS is a GUI-based alignment, programming, and diagnostics program for various Motorola base station and comparator products. The program is designed to run on any laptop or desktop personal computer that is capable of running Microsoft Windows XP, Windows Vista, Windows 7 or Windows Server 2008 R2.

This chapter provides information on frequently performed operations such as launching the RSS program and downloading a codeplug from a connected device. The following topics are included:

- “User Interface Description” on page 2-2
- “PC Requirements” on page 2-4
- “Installing the RSS Software” on page 2-4
- “Connecting the PC to the Device RSS Port” on page 2-11
- “Launching the RSS Program” on page 2-12
- “Exiting the RSS Program” on page 2-13
- “Navigating Through the RSS Screens” on page 2-17
- “Reading the Device Codeplug” on page 2-14
- “Writing Codeplug Data to the Device” on page 2-20
- “Obtaining Codeplug Size” on page 2-21
- “File Maintenance” on page 2-21 (including saving and opening archive files)

## Summary of Features

---

The RSS program provides the following features and capabilities:

- Read and program device codeplug data
- Create replacement codeplug files based on default codeplug template files included with the RSS program
- Optimize newly installed devices
- Modify or upgrade existing installations

- Perform device alignment procedures
- Interrogate and interpret device status log files
- Perform comprehensive diagnostics on all device modules
- Perform digital metering to measure key voltages and levels

## User Interface Description

The RSS program’s graphical user interface provides a menu, a toolbar, a function structure tree pane, and a work area pane. See Figure 2-1, Figure 2-2, and Figure 2-3 for examples and descriptions of the RSS window, toolbar, and menus.

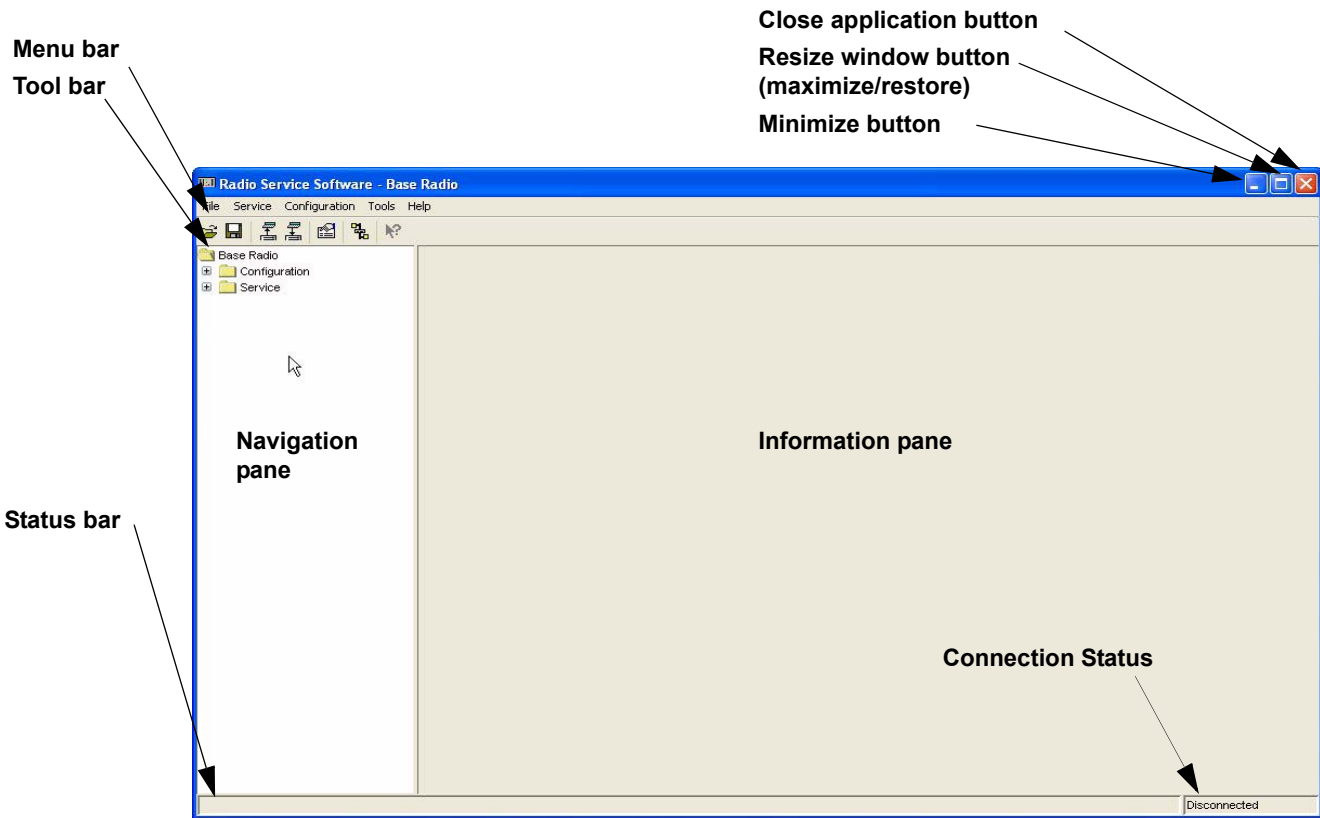


Figure 2-1 RSS Window Overview



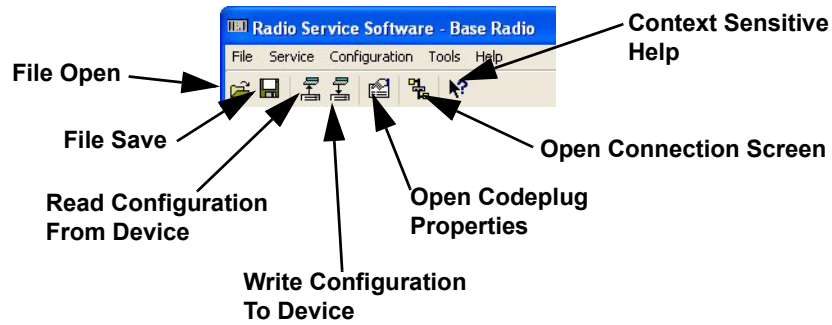


Figure 2-2 RSS Toolbar Buttons



**NOTE**

The Service and Configuration menus shown in Figure 2-3 are for a QUANTAR codeplug. The menus are slightly different if a comparator codeplug is loaded.

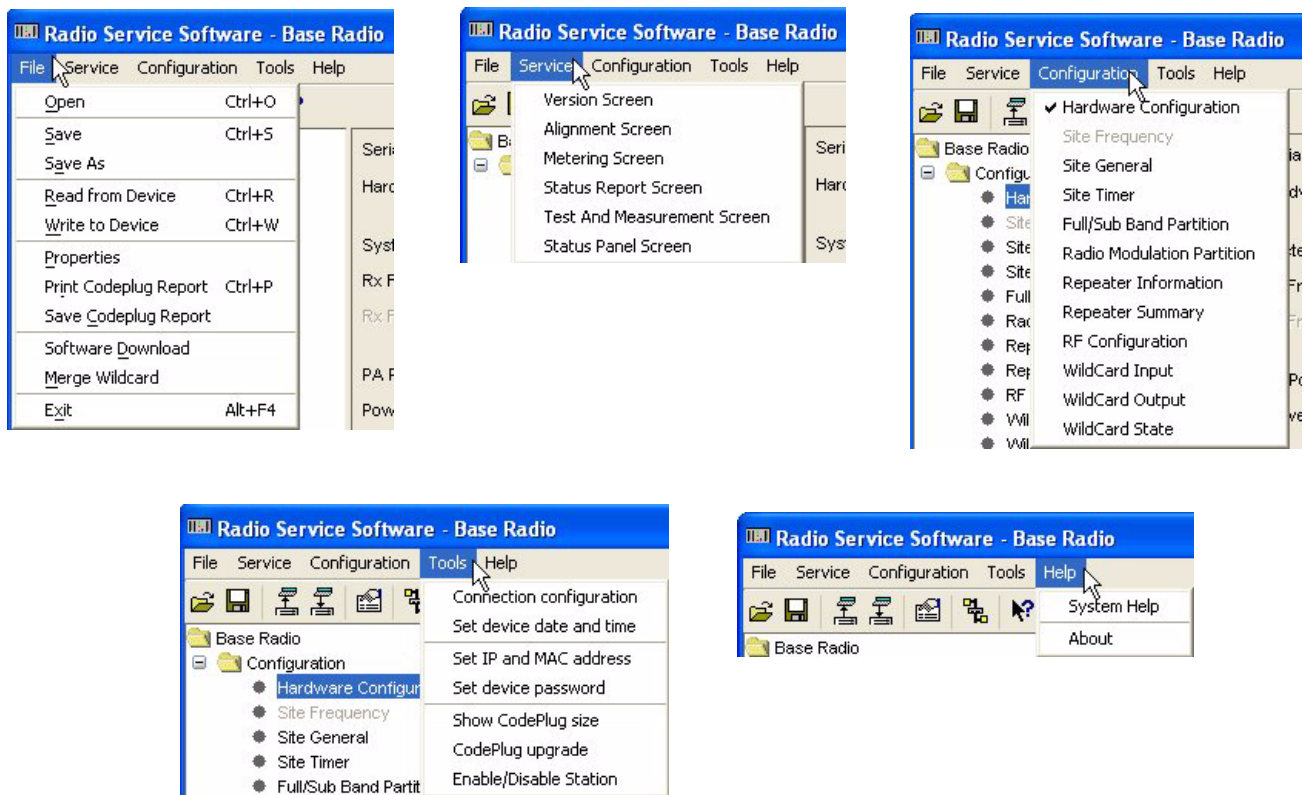


Figure 2-3 RSS Menus

## PC Requirements

The following list provides the hardware requirements for the computer that has the RSS installed on it:

- CD/DVD drive
- One serial communications port
- Microsoft Windows XP operating system with Service Pack 3, Windows Vista operating system with Service Pack 2, Windows 7 operating system with Service Pack 1 or Windows Server 2008 R2 operating system with Service Pack 1.
- 110 MB free hard disk space for use by the RSS program.

## Installing the RSS Software

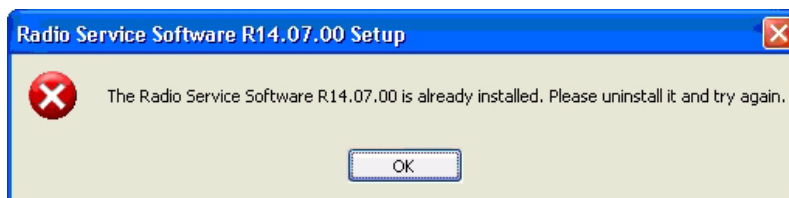
The RSS software is provided on a CD. To install the RSS software, perform the following procedure:



### NOTE

Before proceeding, ensure that the system requirements are met as outlined above.

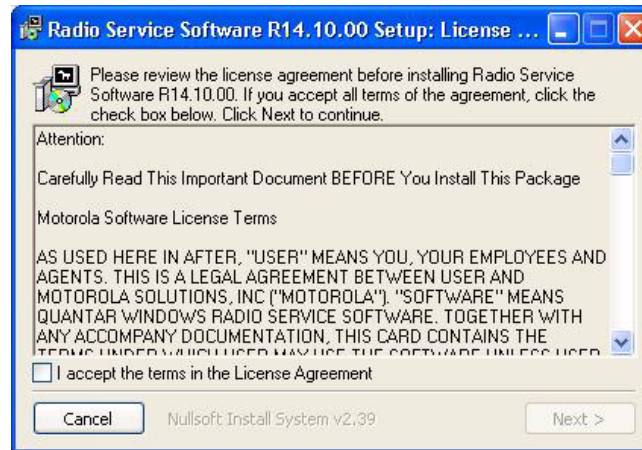
1. Insert the RSS distribution CD into the computer's CD-ROM or DVD drive. In systems set up for self-launching executables, setup.exe launches automatically:
  - If the installation program launches automatically, proceed to step 4.
  - If the installation program does not launch automatically, proceed to the next step.
  - If a previous RSS version is found to be installed, then the following window appears.



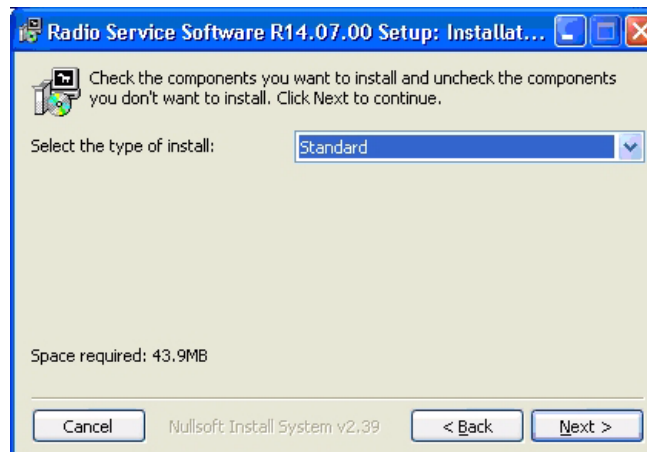
Proceed to “Removing a Previous RSS Version” on page 2-8. When complete, return to this section.

2. Using either Windows Explorer or My Computer, navigate to the CD-ROM or DVD drive holding the RSS distribution CD.

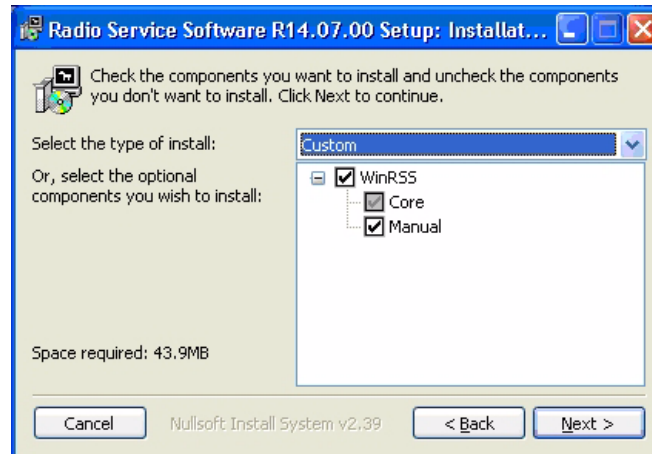
3. Double-click **setup.exe** to launch it. The installation wizard sets up the system for RSS installation. Wait until the initial installation wizard window appears.



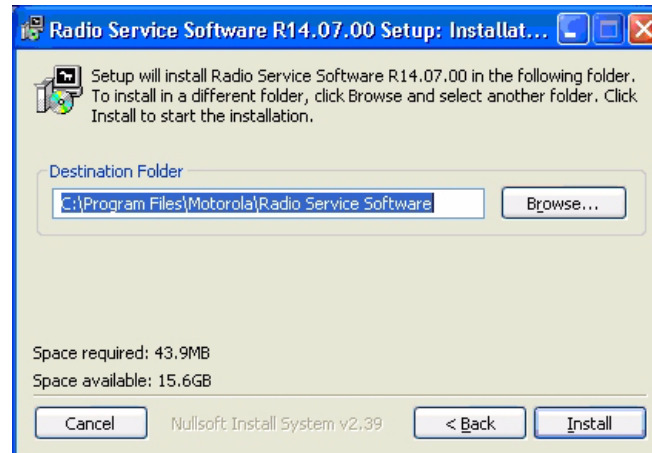
4. Read the license agreement and click **I accept the terms of the license agreement** selection to accept the terms of the license.
5. Click **Next**. The Setup Type window appears.



6. There are two options for installing the RSS application:
  - The **Standard** installation selection installs all components of the RSS application. If this is acceptable, then click **Next**, and the Destination Location window appears. Proceed to step 8.
  - The **Custom** installation selection allows you to choose the components of the RSS application to be installed. When you click **Next**, the Select Features window appears.

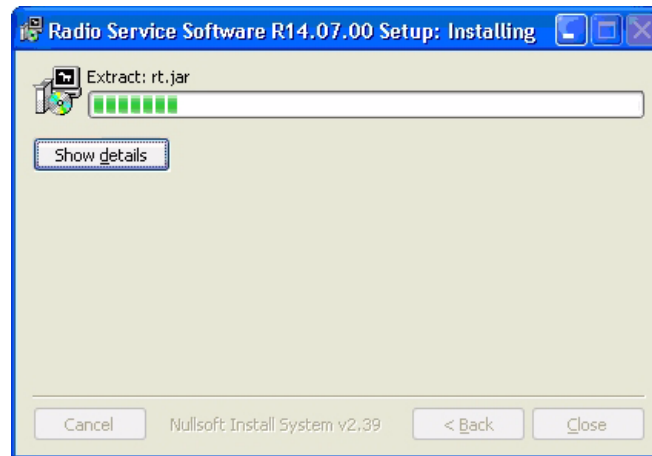


7. Select the components to be installed, then click **Next**. The Destination Location window appears.

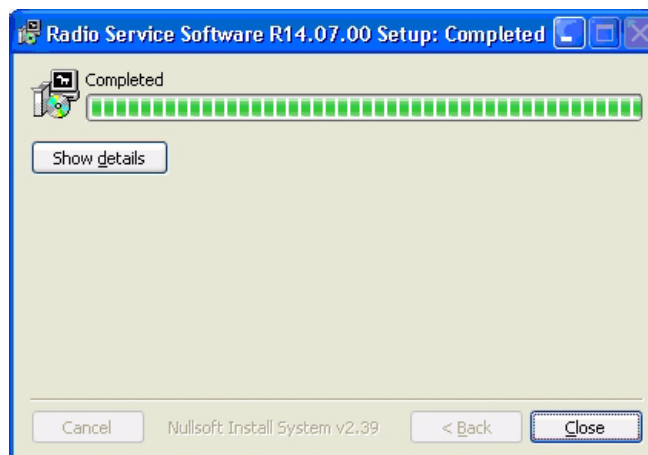


8. If the directory shown for program installation is acceptable, click **Install**. Otherwise, click **Browse** to select or create the desired directory, then click **Install**.

- The installation wizard installs the RSS application and indicates its progress in the status window shown in the following example.



- The completion window shown below appears when the RSS software has been successfully installed.

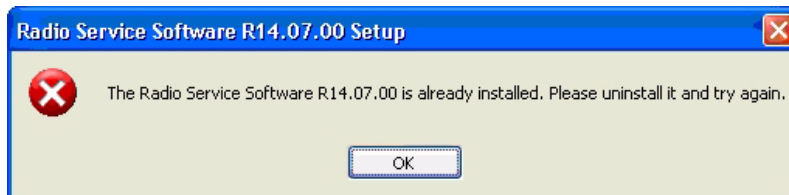


- Click **Close**. The installation wizard closes. The RSS program has been installed.

## Removing a Previous RSS Version

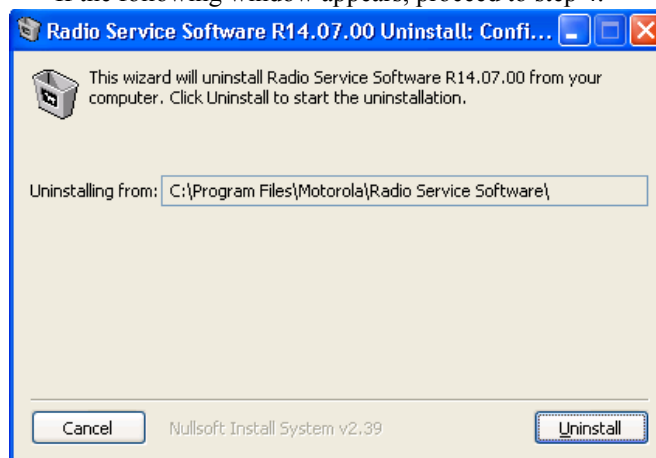
Perform the procedure in this section if the installation routine has found a previous RSS version installed on your computer.

The following screen appears in this situation.



1. From the Start menu in Windows, select **Control Panel**.
2. From the Control Panel:
  - For Windows XP, select **Add or Remove Program**.
  - For Windows Vista, Windows 7 or Windows Server 2008 R2, select **Programs and Features**.
3. From the list of programs, select **Radio Service Software**.
  - For Windows XP, click the **Remove** button.
  - For Windows Vista, Windows 7 or Windows Server 2008 R2, click the **Uninstall** button.

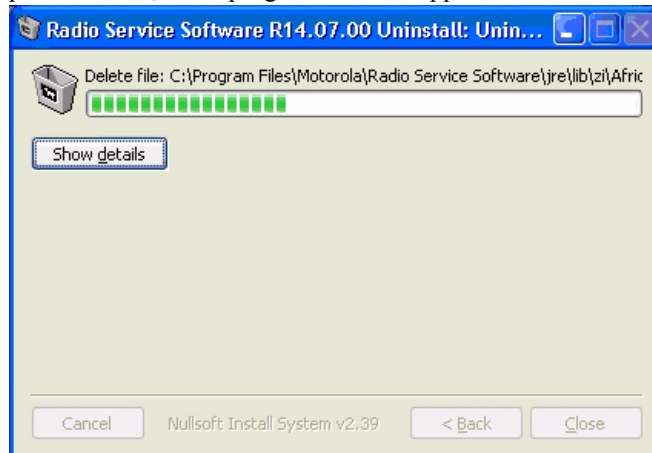
If the following window appears, proceed to step 4.



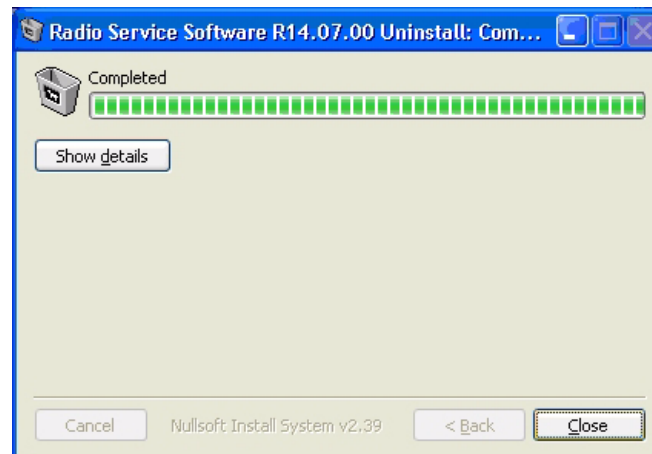
If the following window appears, proceed to step 7.



- Click **Uninstall** to remove the previous version's program and features. The uninstall process starts, and a progress window appears.

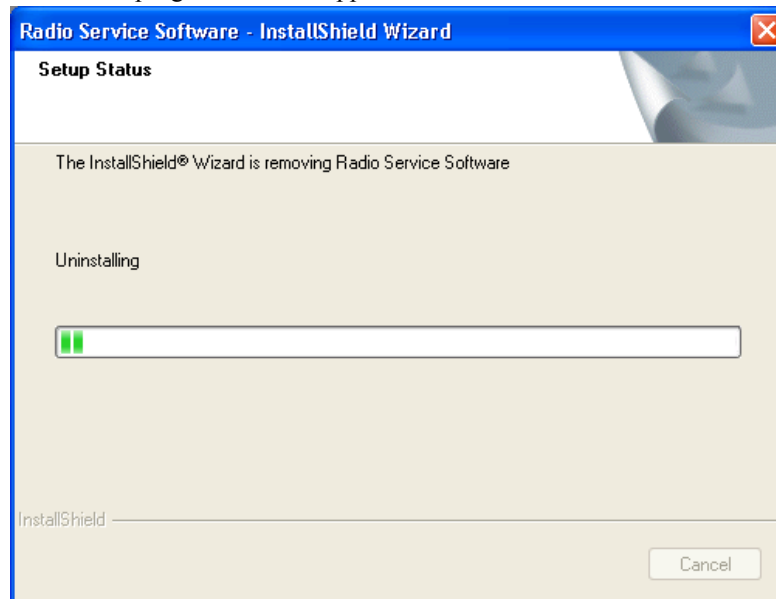


- When the uninstallation process completes, the progress window automatically closes and the following window appears.

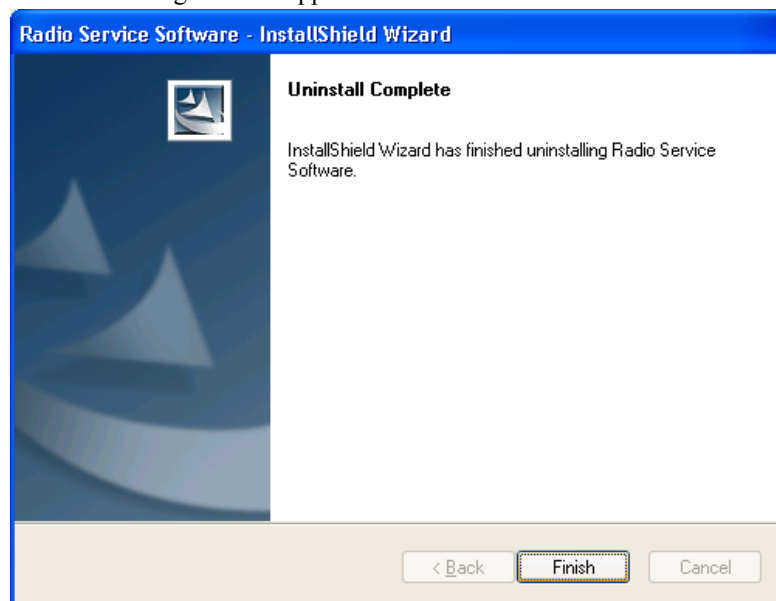


- Click **Close** to close the window. Proceed to step 9.

7. Click **Yes** to remove the previous version's program and features. The uninstall process starts and a progress window appears.



8. When the uninstallation process completes, the progress window automatically closes, and the following window appears.

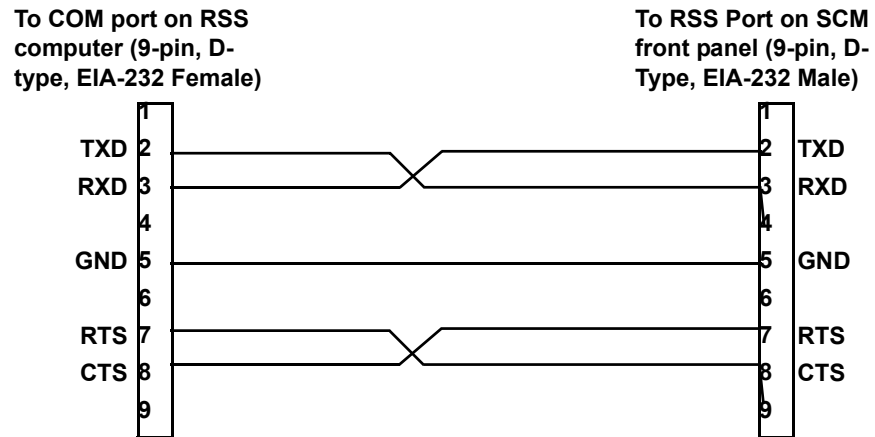


9. Proceed to "Installing the RSS Software" on page 2-4 to install the latest RSS version.



## Connecting the PC to the Device RSS Port

A nine-pin male to nine-pin female EIA-232 null-modem cable (Motorola part number: 30-80369E31) is required to connect the computer to the device. Figure 2-4 provides a null-modem cable wiring diagram.



**Figure 2-4** Null-Modem Cable Wiring Diagram

Connect the null-modem cable from the serial port of the computer running the RSS to the RSS port on the device control module as shown in Figure 2-5.

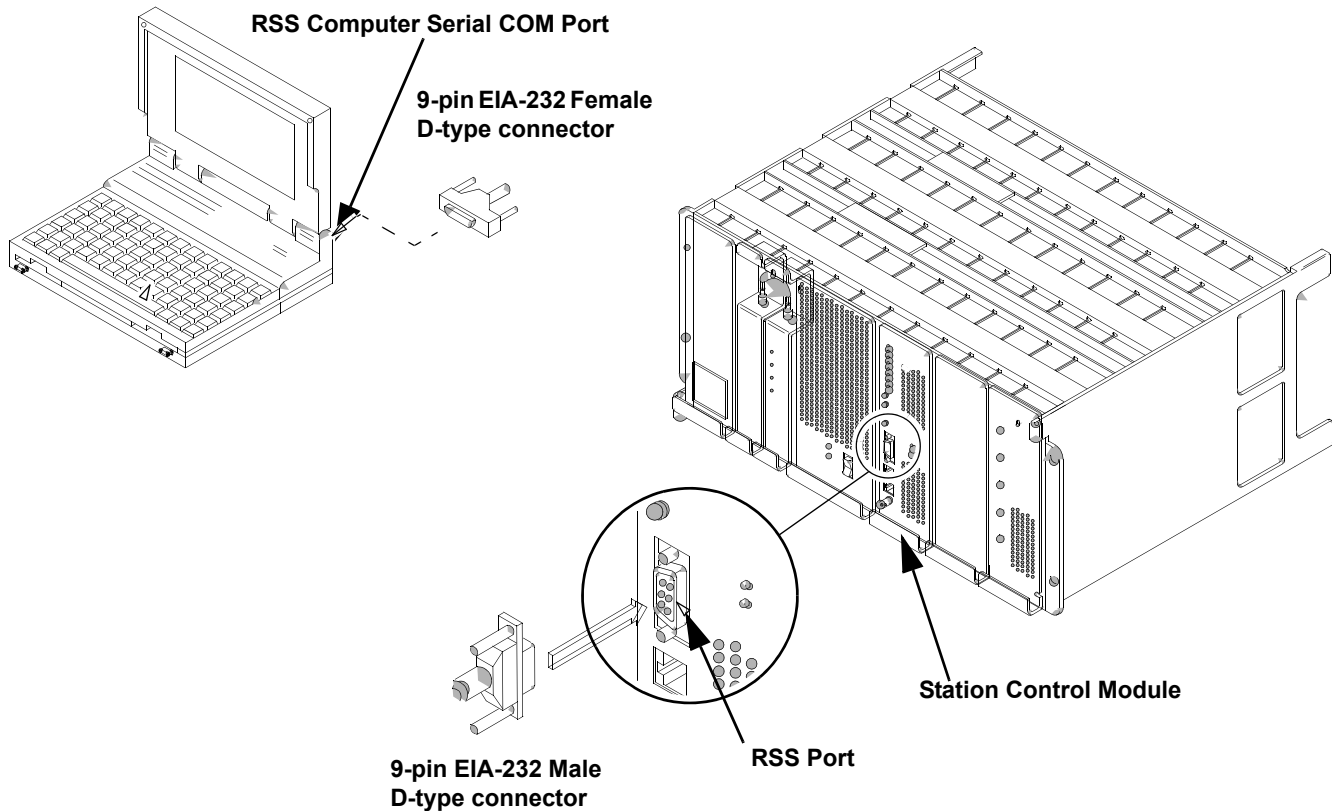


Figure 2-5 RSS Cable Connections



#### NOTE

The RSS cable can also be connected to the back of the chassis on connector #20.

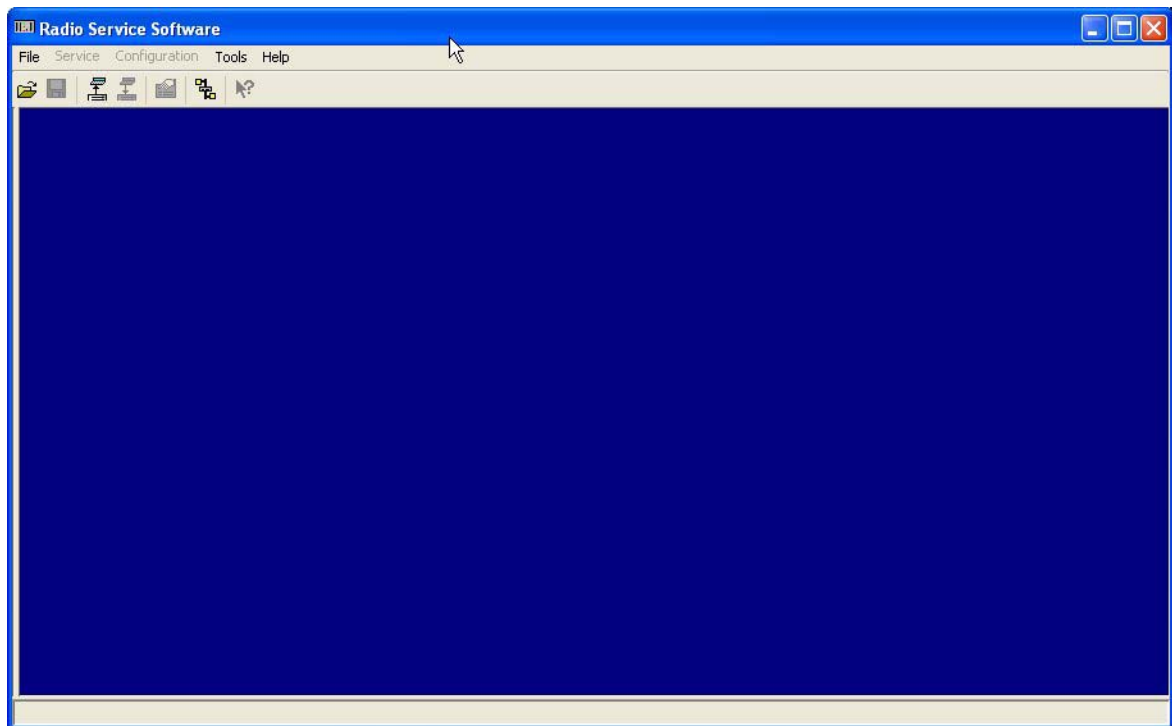
## Working with the RSS Program

### Launching the RSS Program

1. Launch the RSS program by either:
  - Double-clicking the shortcut icon placed on your desktop or
  - Selecting Radio Service Software from the **Start/All Programs/Motorola/Radio Service Software** menu. The splash screen appears as shown in the example below.



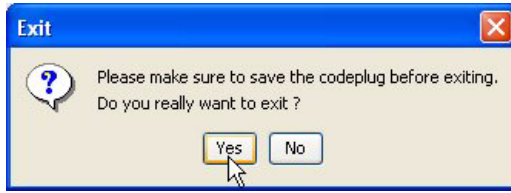
2. When the green progress bar completely fills its area, click **Continue**. The RSS window appears.



The RSS program is now ready to connect to the device to read its codeplug.

## Exiting the RSS Program

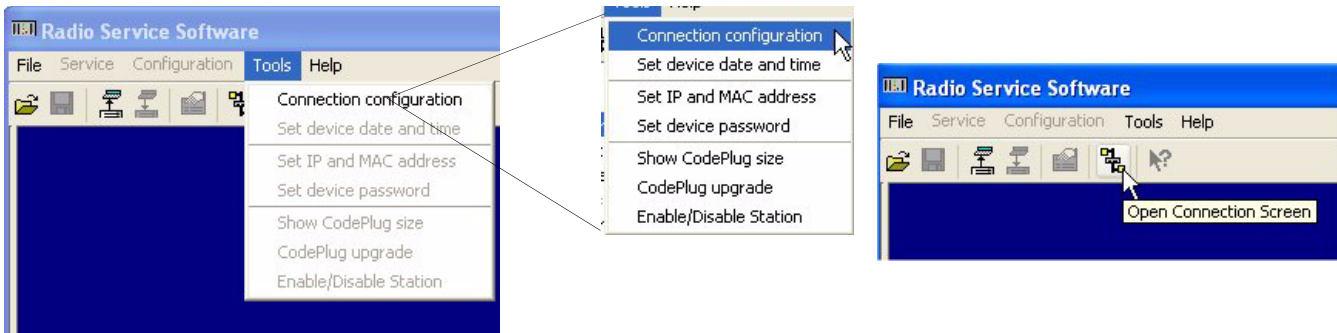
To exit the RSS program, click **X** in the upper right corner of the RSS program window or from the **File** menu, select **Exit**. When the Exit message appears, click **Yes** to close the RSS program.



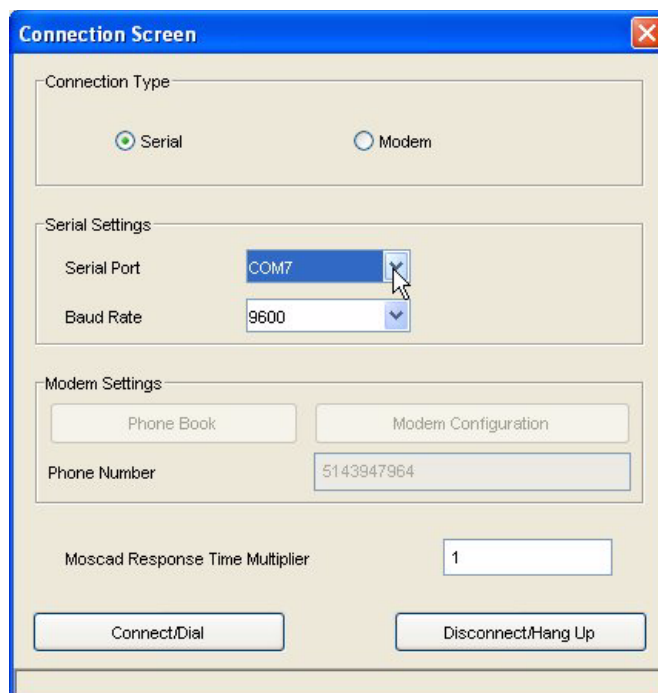
## Reading the Device Codeplug

To read the device codeplug, perform the following steps:

1. Launch the RSS program and connect to the device (base station) as outlined in “Launching the RSS Program” on page 2-12.
2. Click either:
  - Tools then Connection Configuration, or
  - Open Connection Screen icon



The Connection Screen window appears as shown in Figure 2-6.



**Figure 2-6** Connection Screen Window

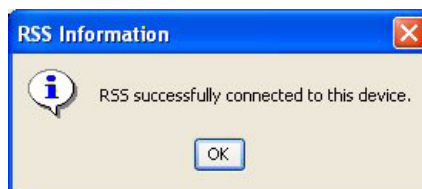
3. Select the appropriate connection type (serial or modem).
4. Verify that the COM port selection is correct. The RSS program is provided with available COM port information. The baud rate defaults to 9600.



#### WARNING

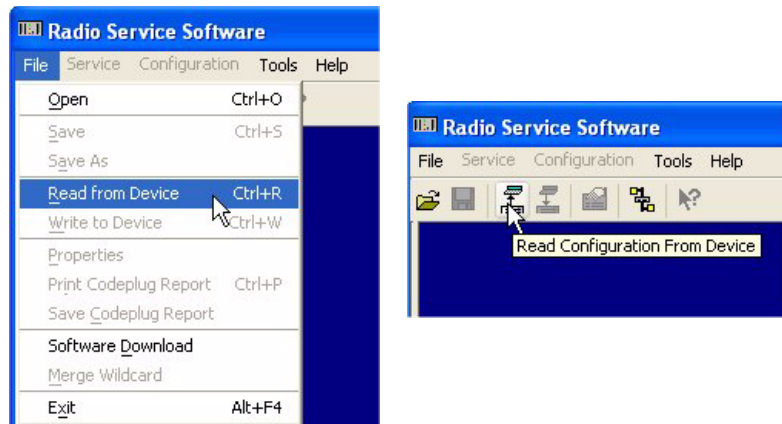
**If the base station is not connected to a transmitting antenna or to an appropriate piece of test equipment capable of handling the output, you must connect a dummy load to the transmitter output. Do not key the transmitter or use the station to transmit RF unless its transmitter output port is connected either to a transmitting antenna or to a 50  $\Omega$  high-power dummy load.**

5. Ensure that the device is turned on and click **Connect/Dial**. The RSS attempts to connect to the device. If successful, the following message appears.



6. Click **OK**. The RSS Information window closes.

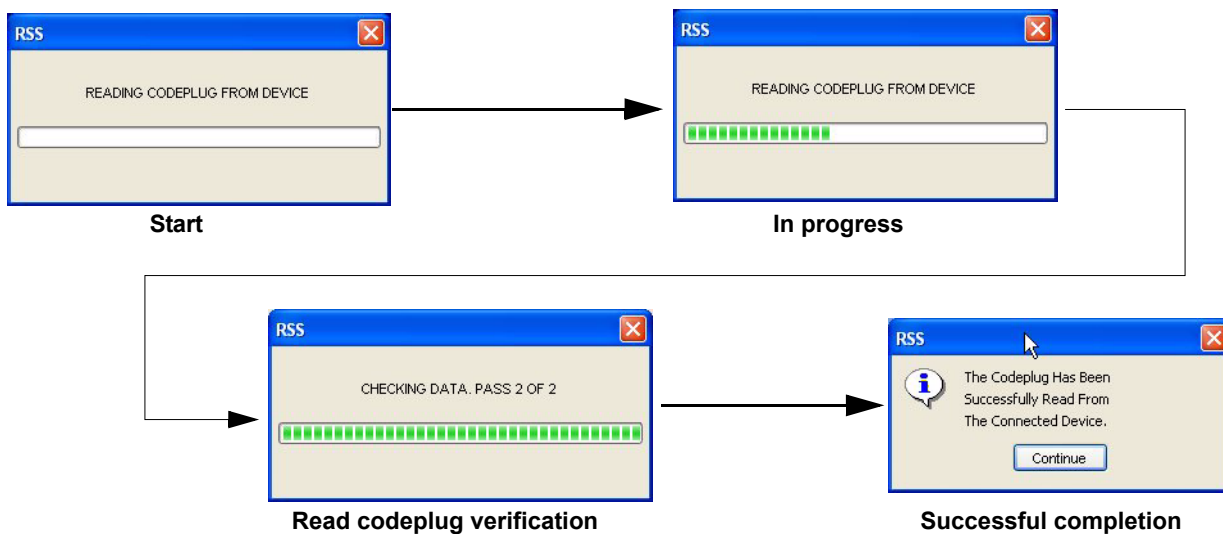
7. Download the current codeplug information from the connected device by either:
  - From the **File** menu, select **Read from Device**.
  - Clicking **Read Configuration From Device** toolbar icon.



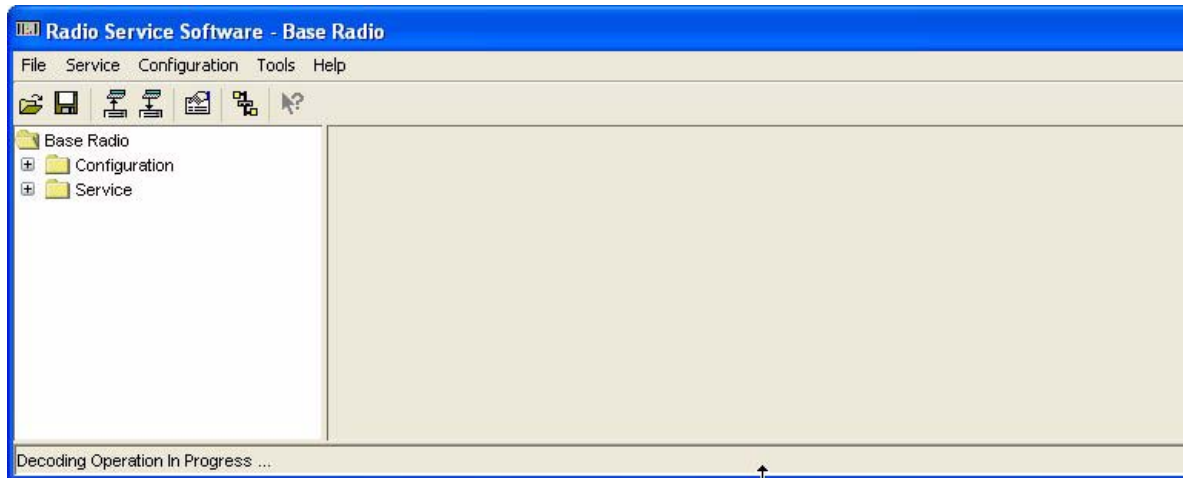
If the device requires a password, the Station Password Prompt window appears.



If required, enter the device’s password and click **OK**. The RSS retrieves the codeplug data from the device and stores it on the PC, displaying the progress.



8. Click **Continue**. The RSS window displays the following screen.



You can now review and configure the device's codeplug settings and perform diagnostic procedures.

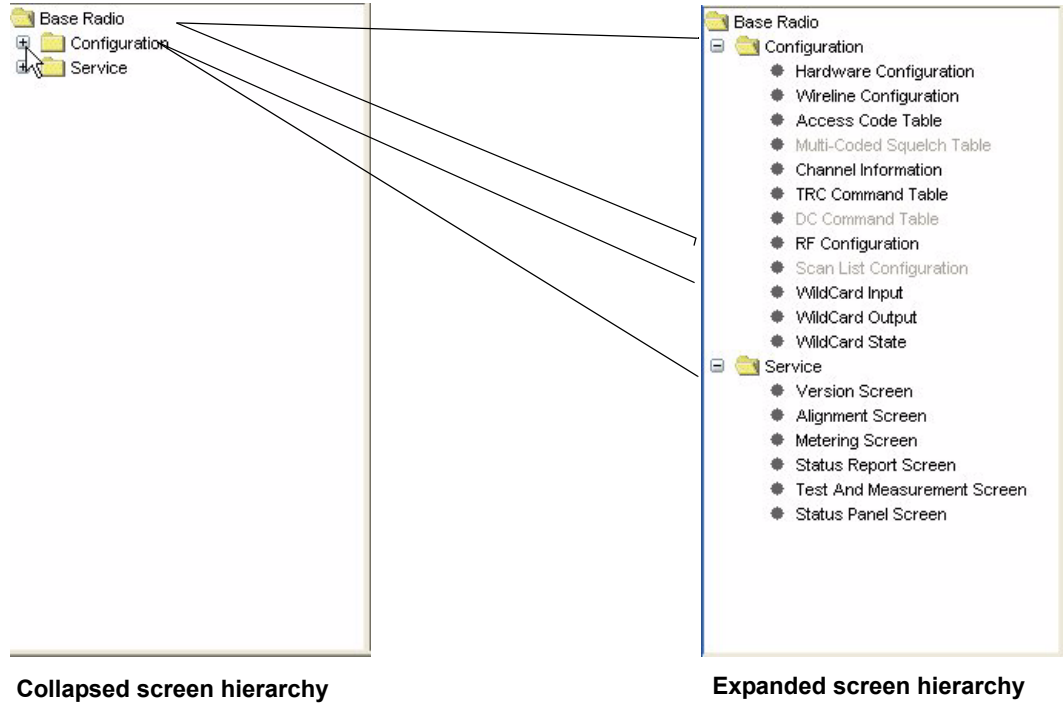


#### IMPORTANT

It is advised that you save the opened codeplug as an archive before you begin changing codeplug parameters and settings. See “Saving Configuration Data to an Archive File” on page 2-22. This is important if your changes create problems, because it allows an easy way to revert the connected device to a functional codeplug.

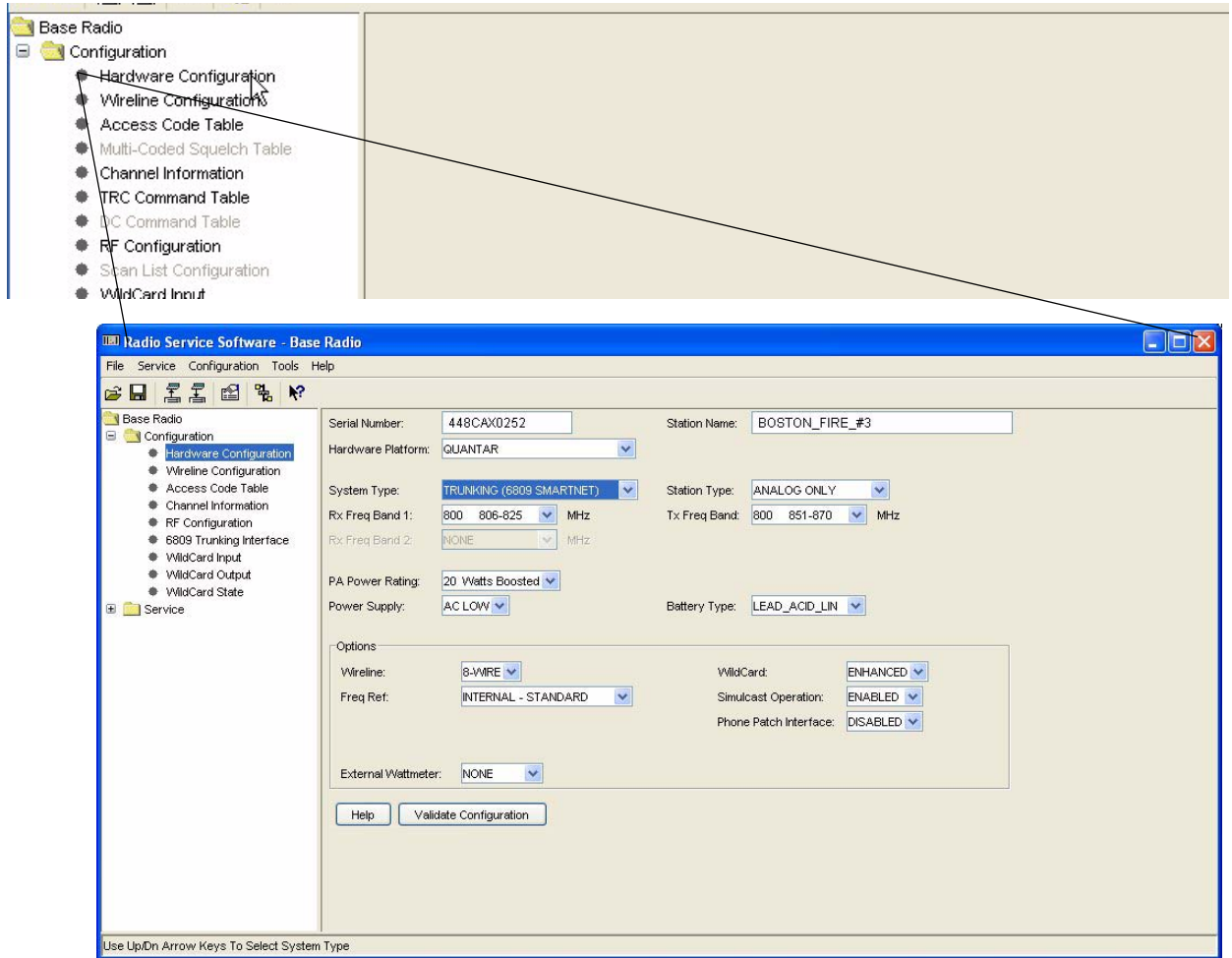
## Navigating Through the RSS Screens

Use the navigation pane of the RSS program window to access the various screens. Clicking the + signs in the screen hierarchy expands that branch to show the applicable information screens for a QUANTAR station.



Clicking a screen name imports the information into the information pane.





Clicking another screen name opens that screen in place of the one currently displayed. Unlike previous DOS-based RSS versions, this GUI version allows you to see the entire function list at one time.

Figure 2-7 shows the structure of the information or function presented in each RSS screen.

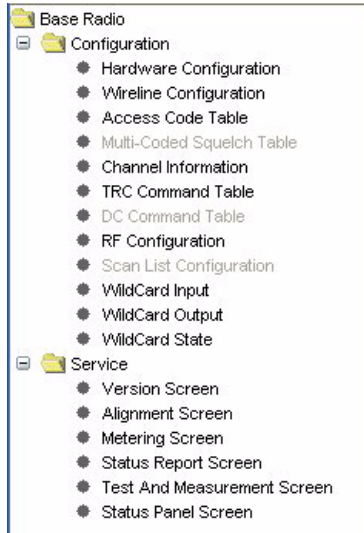
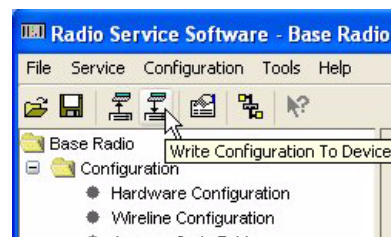
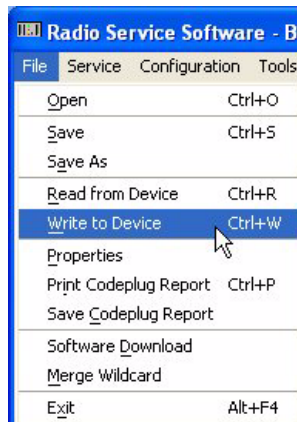


Figure 2-7 RSS Information and Function Screens

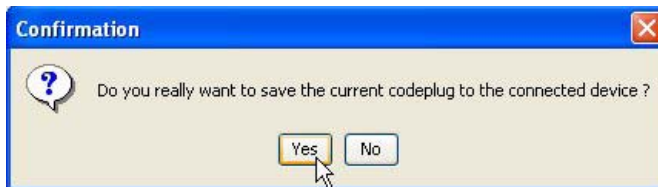
## Writing Codeplug Data to the Device

After changes have been made to the device’s codeplug data, the data must be written to the device. To upload configuration data to the device, perform the following procedure:

1. Do one of the following:
  - From the **File** menu, select **Write to Device**.
  - Click **Write Configuration to Device** icon on the toolbar.

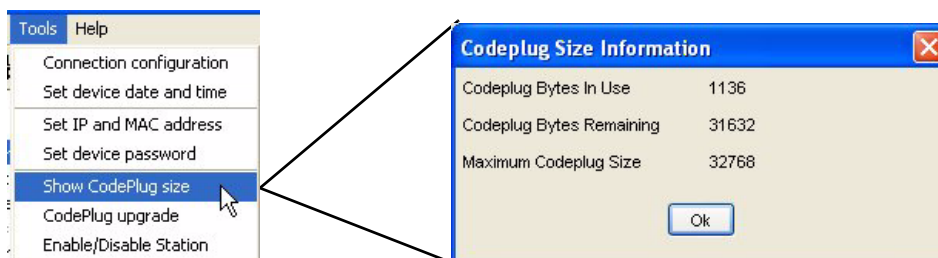


- Click **Yes** when the Confirmation window appears. The RSS program writes the configuration data entered in the current session to the connected device.



## Obtaining Codeplug Size

When the codeplug has been read from the device as outlined in “Reading the Device Codeplug” on page 2-14, you can view the size of the codeplug by choosing **Show codeplug size** from the **Tools** menu. The Codeplug Size Information window displays the codeplug information as shown in Figure 2-8.



**Figure 2-8** Codeplug Size Information Window

## File Maintenance

File maintenance is accomplished through Windows Explorer or My Computer, as preferred. When the RSS is installed on your computer, the installation program creates a default archive directory as follows: `\Motorola\Radio Service Software\archive`. Specifically where this directory tree is located depends on where RSS was installed on your computer.

When working with more than one device, you find it helpful to:

- Create an obvious directory structure to store the codeplug archives for the devices in each of the systems you work on.

- Archive each device’s codeplug immediately after reading it from the device in a folder that identifies the system you are currently working on, as created from suggestion above.
- Add comments to the archive file to further help identify the device to which it belongs.

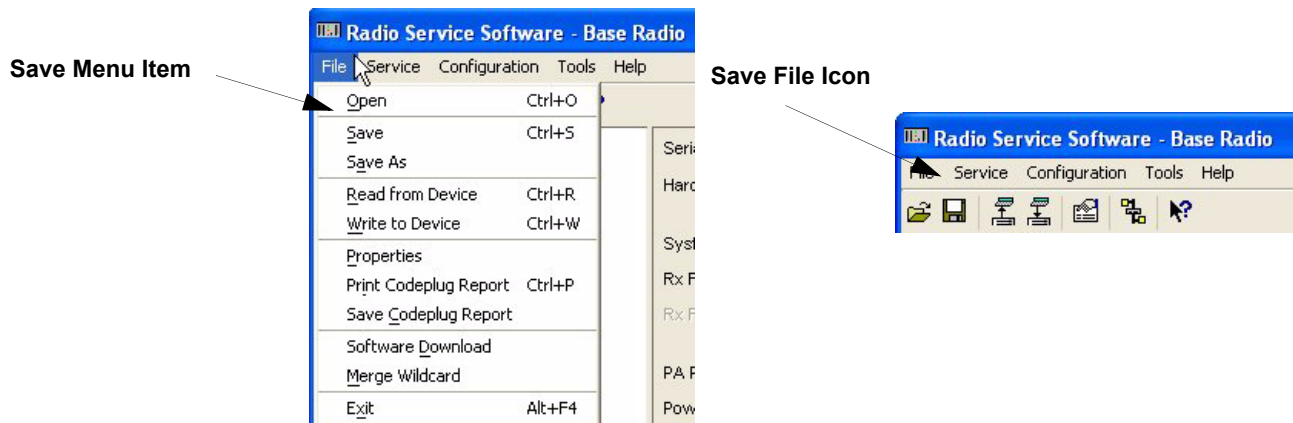
The following sections provide RSS specific file access tasks:

- “Saving Configuration Data to an Archive File” on page 2-22.
- “Opening an Archive Codeplug File” on page 2-24.

The balance of file maintenance and disk operations, such as directory creation, are accomplished using the Windows operating system tools.

## Saving Configuration Data to an Archive File

1. To save the current session’s configuration data to an archive file, perform either of the two:
  - From the **File** menu, select **Save**. A browser window appears.
  - Click **Save** on the toolbar.

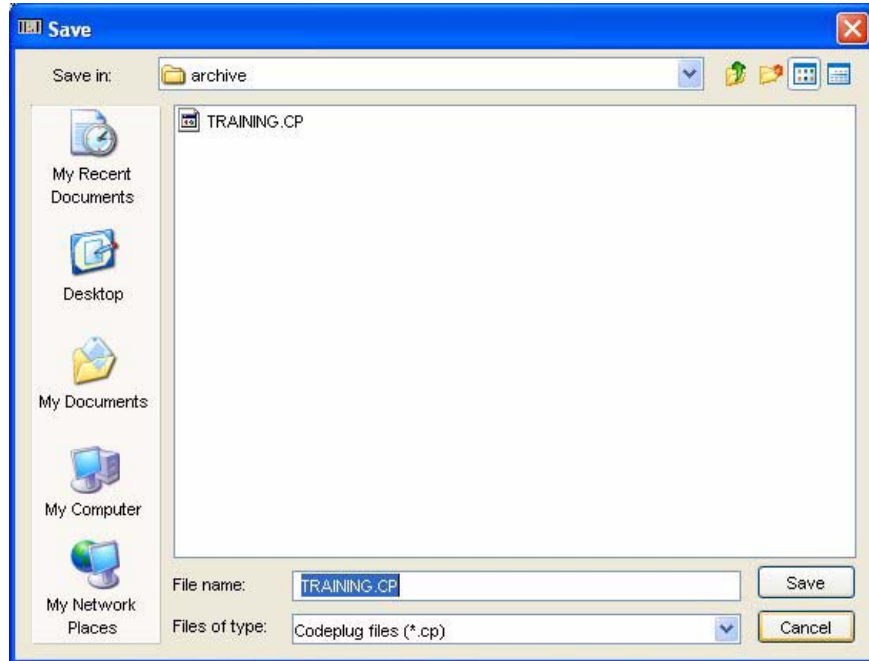


2. The **Save** window appears. Browse to the directory where you want to save this archive or create the directory.

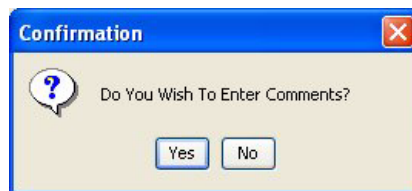


### NOTE

Carefully consider how you name the directories and files. Name them appropriately to simplify locating archive files later.



3. In the **Save** window, name the file appropriately in the **File name** field.
4. Click **Save**. A message window appears.

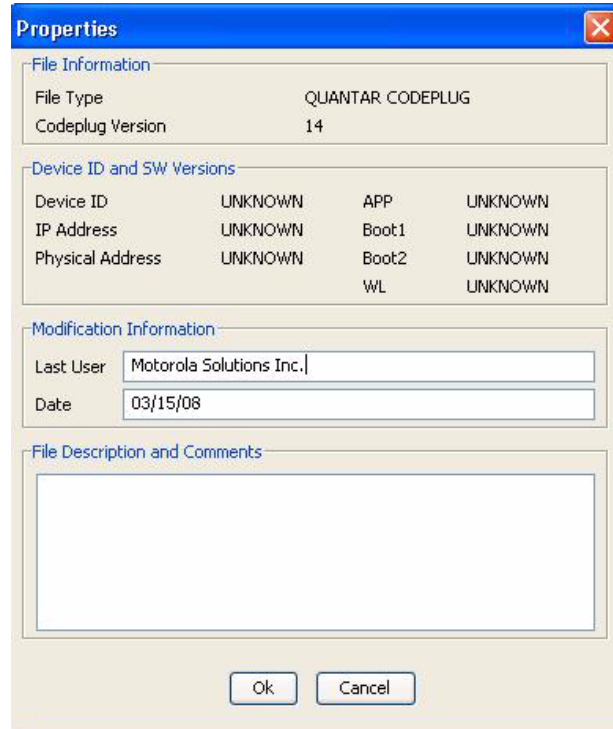


5. Click **Yes**. The Comments window appears.



#### NOTE

It is recommended to enter comments to aid in the identification of the codeplug.



6. Enter appropriate information in the **Last User**, **Date**, and **File Description and Comments** fields.



#### NOTE

Comments should be explicit enough to help you locate the archive file if needed. The information entered here is available when opening a file using **Preview** in the **Open** window to help in file identification.

7. When done click **OK**. The following window appears when the codeplug is saved as an archive. Click **Continue**.

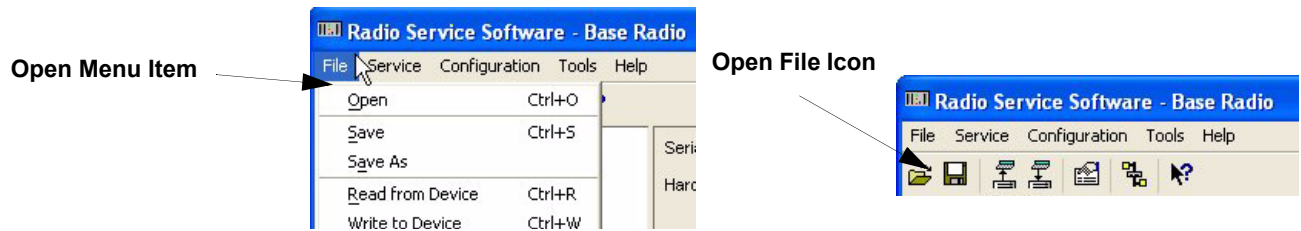


## Opening an Archive Codeplug File

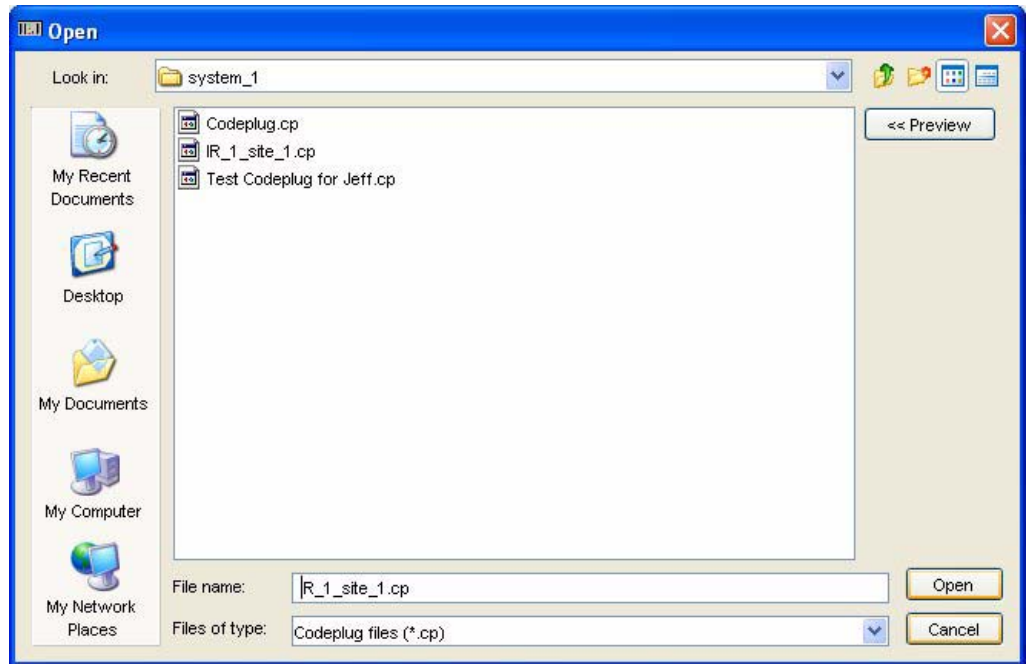
To open an archive codeplug file, perform the following steps:

1. To open an existing archive file, perform either of the two as given below:
  - From the **File** menu, select **Open**. A browser window appears or

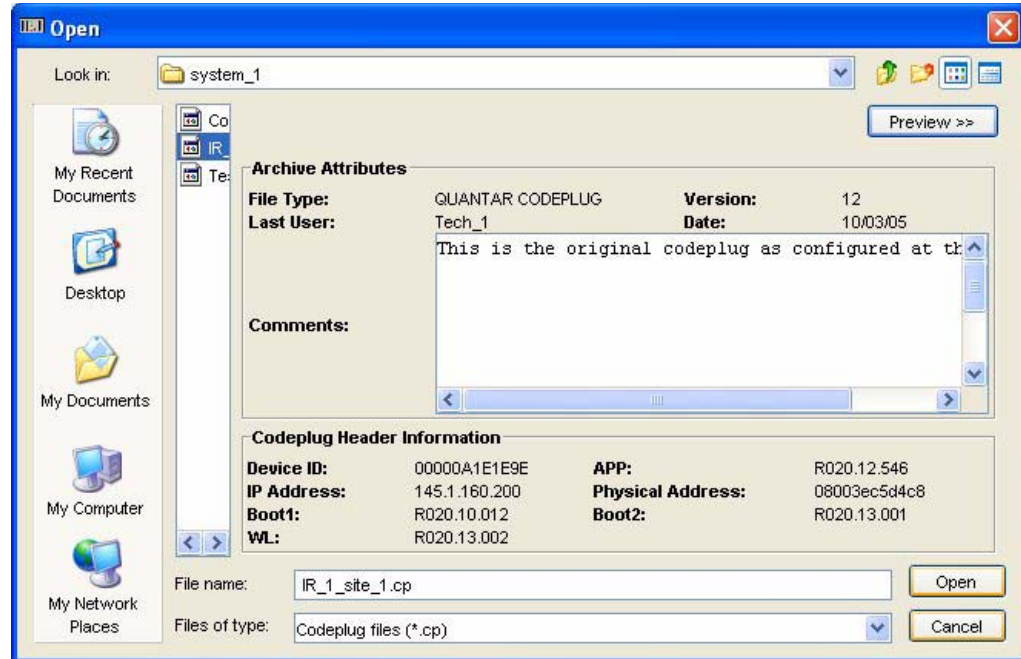
- Click **Open** on the toolbar.



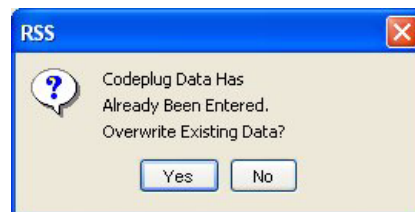
2. The **Open** window appears. Browse to the directory where you saved the archive file.



3. Select the archive file you want to open. If required, select the file name and then click **Preview**. This displays information about the archive file entered at the time the archive was created. See the example below.



4. Click **Open** to open the file. The codeplug archive is opened in the RSS window. If a codeplug is already loaded in the RSS, the following warning message appears.



5. Click **Yes** to overwrite the currently loaded codeplug. The following message window appears when the archive file is successfully loaded in the RSS.





# Optimization

---

Base stations must be optimized after the initial installation and after the maintenance actions such as retuning or replacing modules. Optimization includes tasks such as verifying the station hardware configuration, performing alignment, and programming the station's codeplug. The general process for optimizing a base station is as follows:

1. Connect the RSS computer to the station. See "Connecting the PC to the Device RSS Port" on page 2-11.
2. Launch the RSS program as outlined in "Launching the RSS Program" on page 2-12.
3. Read the station's codeplug. See "Reading the Device Codeplug" on page 2-14.
4. Verify that the station's configuration data, as sent from Motorola, is as specified in the purchase order. See "Verifying the Device's Configuration Data" on page 3-3.
5. Customize the codeplug for the station's specific installation if required. See the following as required for the specific system:
  - "Programming the IP Address" on page 3-6
  - "Programming the MAC Address" on page 3-7
  - "Setting the Device's Date and Time" on page 3-8
  - "Creating the Station's Password" on page 8-2
  - "Programming Wireline Configuration Data" on page 3-9
  - "Programming the Access Code Table Data For Conventional Systems" on page 3-13
  - "Programming the Access Code Table Data for 6809 Trunking Systems" on page 3-15
  - "Programming the Multi-Coded Squelch Table Screen" on page 3-16
  - "Programming the Channel Information Screen" on page 3-20
  - "Programming the TRC Commands Data" on page 3-25
  - "Programming DC Remote Command Data" on page 3-27
  - "Programming the RF Configuration Data Screen" on page 3-29
  - "Programming the 6809 Trunking Interface Data" on page 3-31
  - "Programming the Scan List Configuration Data" on page 3-32
  - "Programming the IntelliRepeater" on page 3-35

6. Save the updated configuration data to a file on the RSS computer as an archive of the device's current configuration as outlined in "Saving Configuration Data to an Archive File" on page 2-22.
7. Save the updated configuration data to the device's codeplug as outlined in "Writing Codeplug Data to the Device" on page 2-20.
8. Perform the following alignments on the device:
  - Rx Wireline ("Procedure A: Rx Wireline Alignment Procedure" on page 3-57)
  - Tx Wireline ("Procedure E: Aligning TX Wireline Procedure" on page 3-66)
  - RSSI Calibration ("Aligning Radio Signal Strength Indicator (RSSI)" on page 3-68)
  - Squelch Adjust ("Aligning Squelch Adjust Procedure" on page 3-71)
  - Battery Equalization (if battery equipped: "Equalizing Batteries" on page 3-73)
  - Reference Oscillator of UHSO ("Calibrating Reference Oscillator Procedure" on page 3-75)
  - ASTRO Alignment and Test (if required: "Setting ASTRO Tx Align and Test Procedure" on page 3-82)
  - ASTRO Pattern Generator ("Generating ASTRO Test Patterns" on page 3-85)
  - TDATA Calibration (if required: "TDATA Calibration (6809 Trunking Station Only)" on page 3-88)
  - ASTRO Bit Error Rate Reports (ASTRO only: "ASTRO Bit Error Rate Reports" on page 3-90)
9. Perform tests to verify that optimization was successful and that the device operates properly ("Post-Optimization Checkout" on page 3-93).

## Required Test Equipment

---

The following equipment is required to perform optimization:

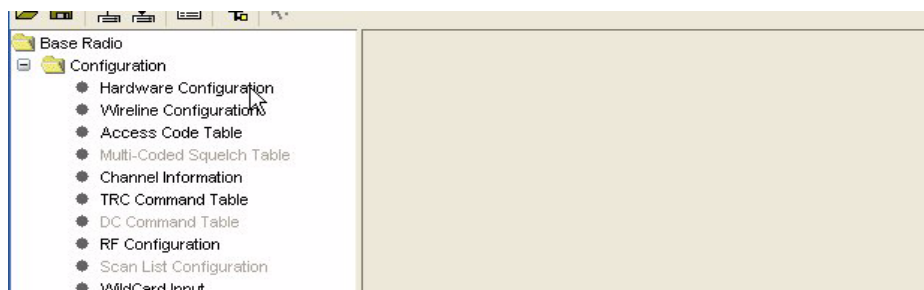
- The RSS computer
- Communications Analyzer: Motorola R2001 (or equivalent) for non-ASTRO systems
- Communications Analyzer: Motorola R2500 (or equivalent) for ASTRO systems

## Verifying the Device's Configuration Data

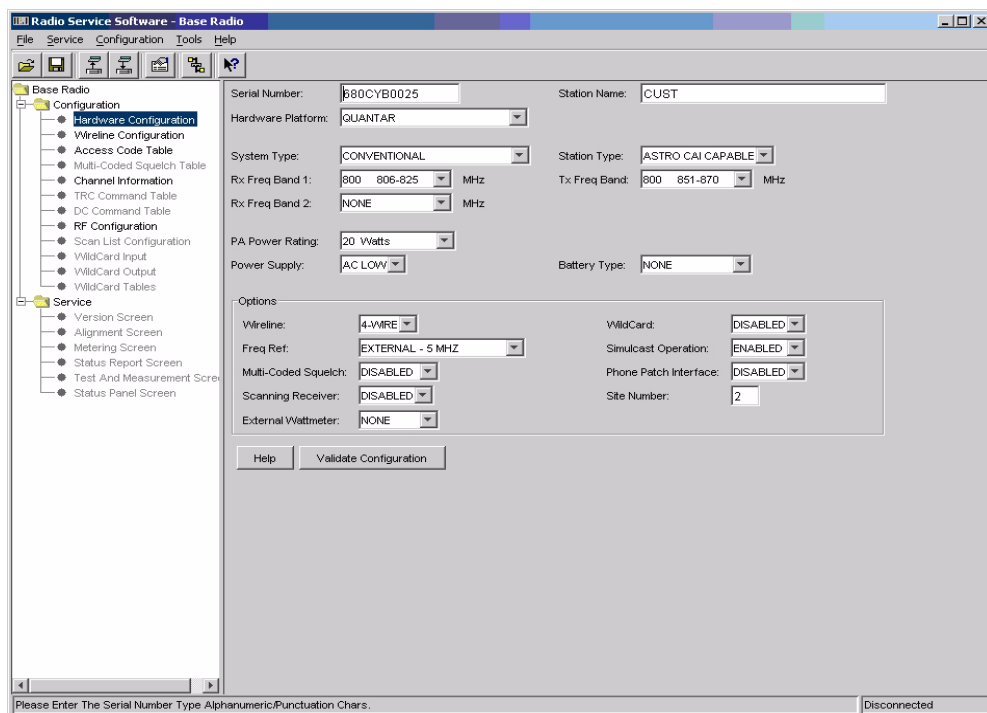
Each device ships from Motorola's factory with a codeplug that has been custom programmed based on information on the sales order. A portion of the device codeplug data includes definitions of the device hardware configuration including serial number, ID, types of modules installed, and system and modulation type. It is recommended that you use the RSS to view this data to ensure it agrees with the equipment you are currently optimizing. Also verify that the equipment configuration agrees with the "vend ticket" shipped with the equipment.

To access the connected device's current configuration data, perform the following procedure:

1. Click the + sign on the Configuration node in the navigation pane to expand the Configuration branch.



2. Click **Hardware Configuration** to display the device's retrieved configuration data as shown in the example below.



You can now read the device's configuration data as programmed at the factory.

**SITE NUMBER Field:** For simulcast stations or voting receivers, the station needs to know its "sub-site" number. This number is used to identify the station for diagnostic reporting as well as for certain infrastructure messages. The system installer must be careful that this number matches the sub-site number known. (For the 6809 determined by placement of the remote site to prime site cabling on the 6809 ACB board.) This field is used for Conventional and 6809 trunking systems, and will only be editable for voting systems, i.e., Wireline Configuration:Comparator not set to NONE.

For ASTRO systems this field assigns to the station an address by which other infrastructure devices may identify it. In a wide area ASTRO system a dispatcher may "site-steer" transmissions to a particular base station by selecting that station on the console or data subsystem prior to transmitting. The comparator then routes traffic to that station utilizing that station's site number value.

See Table 3-1 for the proper site number ranges.

**Table 3-1** SITE NUMBER RANGES

Station Type	Site Number
6809 Trunking	Must be set to 0
6809 Simulcast/Voting	Set to system specific site number, range is 1-16
Conventional	Default value is 1
Conventional Simulcast/Voting	Set to system specific site number, range is 1-62, default value is 1 <b>but must be set to value other than 1 when used with data traffic</b>

- Review the device data shown onscreen to verify that it matches the equipment and the system requirements. In most cases it matches the vend ticket, but there are circumstances where there may be discrepancies such as information missing on the original sales order, thus requiring the factory to leave certain fields at default values. The Hardware Configuration screen provides **Validate Configuration** to make sure that the hardware in the device matches the hardware specified on the Hardware Configuration screen. Differences are reported by the RSS through popup screens.
- Click **Version Screen** in the Service tree to review the device's current operating software versions. The information pane displays the current version information as shown in the example below.

Station Control Firmware	R020.12.034	2003/07/23 11:37
Station Wireline Firmware	R020.12.008	2003/07/23 11:37
Station Exciter Firmware	R020.09.010	
Station Boot2 Firmware	R020.10.022	2003/04/02 10:40
Station Boot1 Firmware	R020.10.009	0000/00/00 00:00
Codeplug Version	12	

Help

5. Change the data as required and when done save the configuration data to either:
  - An archive file as outlined in “Saving Configuration Data to an Archive File” on page 2-22, or
  - The device’s codeplug as outlined in “Writing Codeplug Data to the Device” on page 2-20.

## Device Type Programming Overview

After reading the device codeplug data into the RSS computer, it must be reviewed and edited as appropriate to match the system and user requirements specific to the particular device. Table 3-2 provides the relevant screens for each supported device type.

**Table 3-2** Device Types and Applicable Screens

Device Type	Applicable Screens
Conventional	<ul style="list-style-type: none"> <li>• Hardware Configuration screen</li> <li>• Wireline Configuration screen</li> <li>• Access Code Table or Multi-Coded Squelch screen</li> <li>• Channel Information screen</li> <li>• TRC Command Table screen</li> <li>• DC Command Table screen</li> <li>• RF Configuration screen</li> <li>• Scan List Configuration List</li> <li>• WildCard screens</li> </ul>
IntelliRepeater 2.0/3/2.7E	<ul style="list-style-type: none"> <li>• Hardware Configuration screen</li> <li>• Site Frequency screen</li> <li>• Site General screen</li> <li>• Site Timer screen</li> <li>• Full/Sub Band Partition screen</li> <li>• Radio Modulation Partition screen</li> <li>• Repeater Information screen</li> <li>• Repeater Summary screen</li> <li>• RF Configuration screen</li> <li>• WildCard screens</li> </ul>
IntelliRepeater 3.0/3.5/4.1	<ul style="list-style-type: none"> <li>• Hardware Configuration screen</li> <li>• Site Frequency screen</li> <li>• Site General screen</li> <li>• Site Timer screen</li> <li>• Full/Sub Band Partition screen</li> <li>• Radio Modulation Partition screen</li> <li>• Repeater Information screen</li> <li>• Repeater Summary screen</li> <li>• RF Configuration screen</li> <li>• WildCard screens</li> </ul>
6809 SmartZone Trunking	<ul style="list-style-type: none"> <li>• Hardware Configuration screen</li> <li>• Wireline Configuration screen</li> <li>• Access Code Table screen</li> <li>• Channel Information screen</li> <li>• RF Configuration screen</li> <li>• 6809 Trunking Interface</li> <li>• WildCard screens</li> </ul>

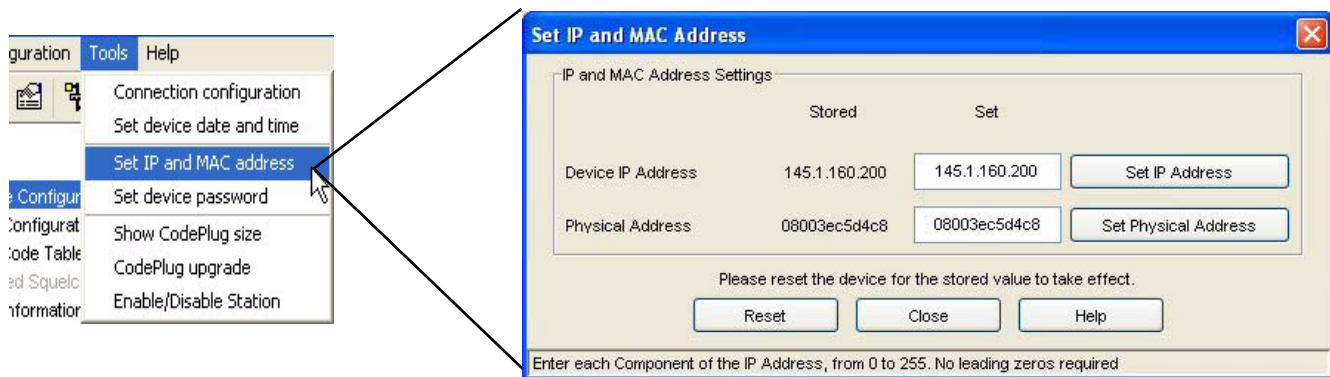
**Table 3-2** Device Types and Applicable Screens (continued)

Device Type	Applicable Screens
6809 SMARTNET Trunking	<ul style="list-style-type: none"> <li>• Hardware Configuration screen</li> <li>• Wireline Configuration screen</li> <li>• Access Code Table screen</li> <li>• Channel Information screen</li> <li>• RF Configuration screen</li> <li>• 6809 Trunking Interface</li> <li>• WildCard screens</li> </ul>
DSSIII	<ul style="list-style-type: none"> <li>• Hardware Configuration screen</li> <li>• Channel Information screen</li> <li>• WildCard screens</li> </ul>
QUANTAR Data Base Station	<ul style="list-style-type: none"> <li>• Hardware Configuration screen</li> <li>• Channel Information screen</li> <li>• WildCard screens</li> </ul>

## Programming the IP Address

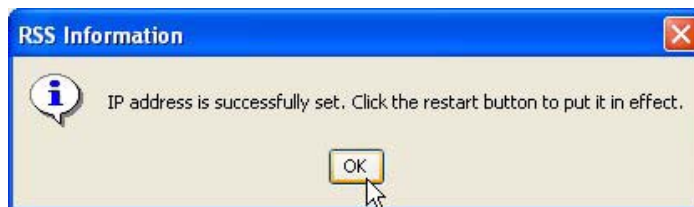
Each device in the system requires a unique IP address for network operation. To set the device's IP address, perform the following procedure:

1. From the **Tools** menu, select **Set IP and MAC Address** as shown in Figure 3-1. The Set IP and MAC Address window appears.



**Figure 3-1** Accessing the IP Address Field

2. Enter the IP address in accordance with your system's network documentation.
3. When done, click **Set IP Address**. The following message window appears.

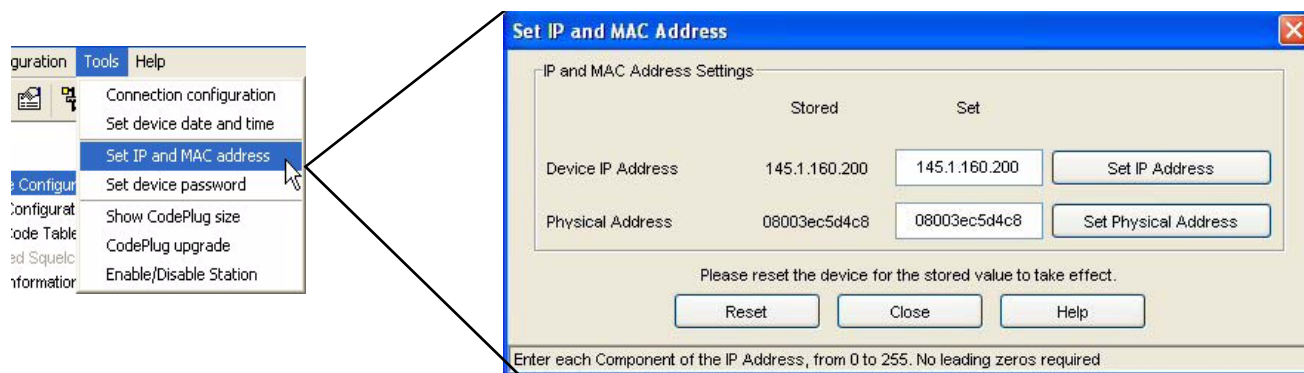


4. Click **OK**. The window closes.
5. You must reset the station to set its IP address to the value you entered. If you do not reset the station at this point, the IP you entered is not set in the device. To reset the device, click **Reset**. The device restarts and uses the IP address you entered when it completes the restart process.

## Programming the MAC Address

The MAC address is generally hardcoded into the network interface and does not require changing unless another device on the network has the same MAC address (a very low probability). This can be treated as a read-only field in most cases. To set the device’s MAC address if necessary, perform the following procedure:

1. To set the device’s MAC address, from the **Tools** menu, select **Set IP and MAC Address** as shown in Figure 3-2. The Set IP and MAC Address window appears.



**Figure 3-2** Accessing the MAC Address Field

2. Enter the MAC address in accordance with your system’s network documentation.
3. When done, click **Set Physical Address**. The following message appears.

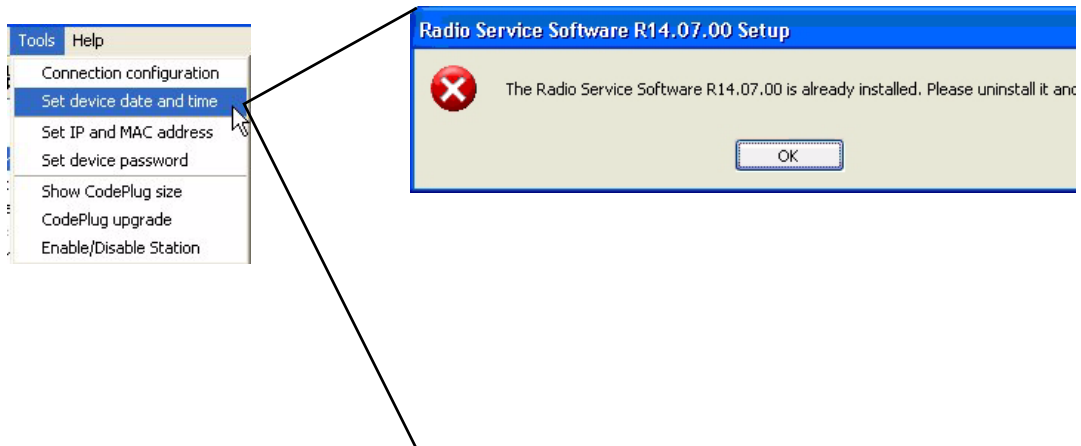


4. Click **OK**. The window closes.
5. You must reset the device to activate its MAC address to the value you entered. If you do not reset the device at this point, the MAC address you entered is not activated in the device. To restart the device, click **Reset**. The device restarts and uses the MAC address you entered when it completes the restart process.

## Setting the Device's Date and Time

To set the device's date and time, perform the following procedure:

1. From the **Tools** menu, select **Set device data and time**. See Figure 3-3.



**Figure 3-3** Set Date and Time Screen

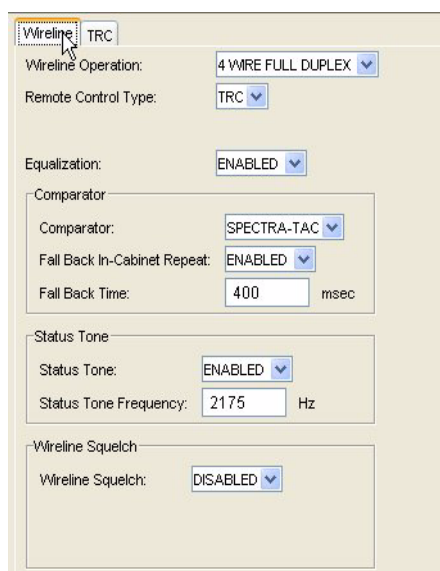
2. The read-only portion of the window displays the RSS computer's current date and time. Set the device's date and time in the appropriate fields.
3. When done, click either **OK** or **Apply**.



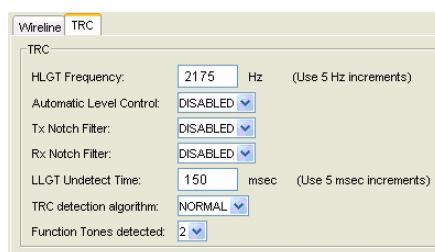
# Programming Wireline Configuration Data

The Wireline Configuration screens allow you to set wireline parameters for device operation. To access the Wireline Configuration screen, click **Wireline Configuration** in the navigation pane. The appearance of the **Wireline Configuration** screen (Figure 3-4) is dependent on the hardware configuration as configured in the **Hardware Configuration** screen.

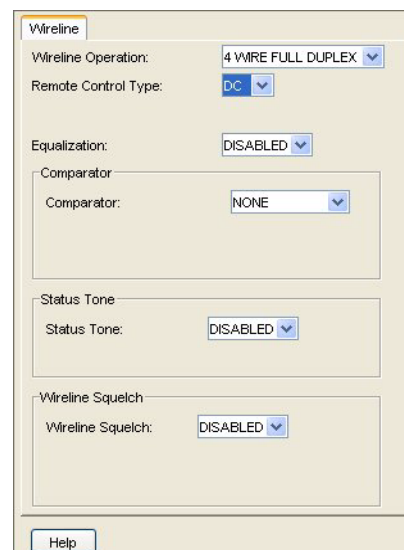
- If the **Station Type** is ANALOG ONLY, then the following applies to the **Wireline Configuration** screen:
  - If the **Remote Control Type** is Tone Remote Control (TRC), then the **TRC** tab is provided for configuration (see Figure 3-4). **TRC Command Table** is provided in the navigation pane to set the TRC commands.
  - If the **Remote Control Type** is DC, then the **Wireline** tab is the only tab provided in the **Wireline Configuration** screen. **DC Command Table** is provided in the navigation pane to set the DC commands.
- If the **Station Type** is ASTRO CAPABLE or ASTRO Common Air Interface (CAI) CAPABLE, then the **Wireline Configuration** screen provides the **Wireline** and **Astro** tabs (see Figure 3-5).



**Analog Station,  
Tone Remote Control,  
Wireline Tab**

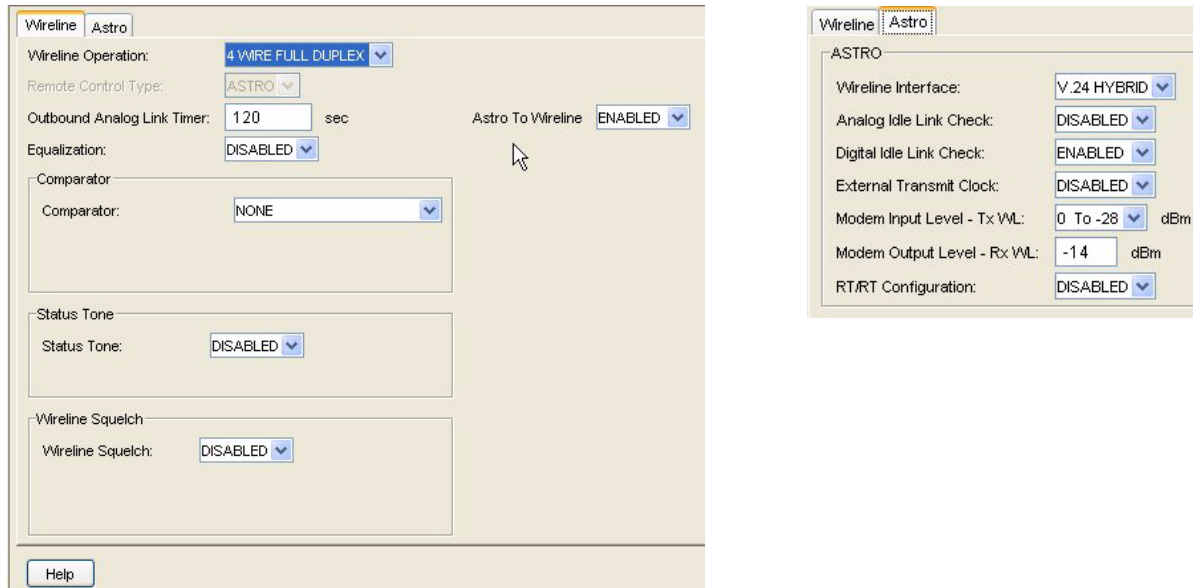


**Analog Station,  
one Remote Control,  
TRC Tab**



**Analog Station,  
DC Remote Control**

**Figure 3-4** Wireline Configuration Screen Examples – Analog Only Station Type



**Figure 3-5** Wireline Configuration Screen Tab Examples – ASTRO Capable or ASTRO CAI Capable Station Type

The following tables provide information about each tab’s parameters:

- Wireline tab: Table 3-3 on page 3-10
- TRC tab: Table 3-4 on page 3-11
- ASTRO tab: Table 3-5 on page 3-12

**Table 3-3** Wireline Tab Parameters

Data Field	Description	Range/Selections	Default	Recommended Setting (if any)
Wireline Operation <sup>1</sup>	Defines the type of wireline communications that exist between the station and remote console.	<ul style="list-style-type: none"> <li>• 2-wire half duplex</li> <li>• 4-wire half duplex</li> <li>• 4-wire full duplex</li> <li>• 6-wire full duplex</li> <li>• 8-wire full duplex</li> </ul>	2-wire half duplex	Set as required by the console connection
Console Priority	If enabled, a console is connected to a 6809 trunked repeater.	<ul style="list-style-type: none"> <li>• Disabled</li> <li>• Enabled</li> </ul>	Disabled	Customer determined
Remote Control Type	Defines the type of remote control used. This field is editable and is determined by the Station Type setting on the Hardware Configuration screen.	<ul style="list-style-type: none"> <li>• ASTRO</li> <li>• TRC</li> <li>• DC</li> <li>• None</li> </ul>	N/A	Determined by system configuration
TRC Input	Specifies the wireline circuit connected to Tone Remote Control.	<ul style="list-style-type: none"> <li>• Line 1</li> <li>• Line 2</li> </ul>	N/A	Display only
Outbound Analog Link Timer	Specifies time interval at which station reports to its connected device that station is receiving an analog call.	20-300 sec	120 sec	Customer determined
Comparator	Specifies the type of comparator in a voting system.	<ul style="list-style-type: none"> <li>• None</li> <li>• DIGI-TAC</li> <li>• SPECTRA-TAC</li> </ul>	None	Determined by system configuration

**Table 3-3** Wireline Tab Parameters (continued)

Data Field	Description	Range/Selections	Default	Recommended Setting (if any)
Fall Back In-Cabinet Repeat	If enabled, station automatically repeats if voting device fails to return signal for transmission with the specified time limit (see below).	<ul style="list-style-type: none"> <li>• Disabled</li> <li>• Enabled</li> </ul>	Disabled	Customer determined
Fall Back Timer	See Fall Back In-Cabinet Repeat.	0 to 10,000 msec	0 msec	Customer determined
Status Tone	Specifies whether status tone (typically 2175 Hz) is placed on wireline during station receiver inactivity.	<ul style="list-style-type: none"> <li>• Disabled</li> <li>• Enabled</li> </ul>	Disabled	Depends on system design.
Status Tone Frequency	Specifies the status tone frequency (typically 2175 Hz) placed on wireline during station receiver inactivity.	2175 Hz	2175 Hz	Customer determined
Wireline Squelch	When enabled, allows the user to configure the Tx Wireline port to squelch the audio (routed to the transmitter) when the audio level falls below the threshold level as set by user. The signal is un-squelched when audio level rises above threshold level plus hysteresis. Threshold level and hysteresis value are set on Service/Alignment/TX Wireline Alignment tab.	<ul style="list-style-type: none"> <li>• Disabled</li> <li>• Enabled</li> </ul>	Disabled	Customer determined
Rx Securenet to Wireline	Determines whether secure signals are sent to console through wireline.	<ul style="list-style-type: none"> <li>• Disabled</li> <li>• Enabled</li> </ul>	Disabled	Customer determined
Equalization	Specifies whether station is allowed to equalize Rx wireline.	<ul style="list-style-type: none"> <li>• Disabled</li> <li>• Enabled</li> </ul>	Disabled	Determined by system configuration

1. The wireline interface board is equipped with a 2-wire/4-wire jumper (JU1010). Ensure that the jumper and Wireline Operation setting are correctly set.

**Table 3-4** Tone Remote Control Tab Parameters

Data Field	Description	Range/Selections	Default	Recommended Setting (if any)
HLGT Frequency	Specifies the frequency used for high level guard tone (HLGT).	1900 to 3000 Hz	2175 Hz	Customer determined
Automatic Level Control (ALC) <sup>1</sup>	If enabled, station automatically aligns Tx Wireline (TRC systems only).	<ul style="list-style-type: none"> <li>• Enabled</li> <li>• Disabled</li> </ul>	Disabled	Customer determined
Tx Notch Filter	Removes LLGT from Tx audio signal. LLGT is same frequency as HLGT as specified above in HLGT Frequency.	<ul style="list-style-type: none"> <li>• Enabled</li> <li>• Disabled</li> </ul>	Disabled	Enabled in systems with TRC. Disabled in all other systems
Rx Notch Filter	Removes HLGT from Rx audio signal. Removal is performed when status tone decoder, such as SPECTRR-TAC, DIGI-TAC, or CIU connected to Rx wireline, may provide false status tone detect due to high content of HLGT in audio signal.	<ul style="list-style-type: none"> <li>• Enabled</li> <li>• Disabled</li> </ul>	Disabled	Enabled in voting or SECURENET systems
LLGT Undetect Time	Specifies the time interval between loss of LLGT and station dekey. Allows for momentary dropout on wireline.	60-2000 msec (5 msec intervals)	150 msec	Customer determined

**Table 3-4** Tone Remote Control Tab Parameters (continued)

Data Field	Description	Range/ Selections	Default	Recommended Setting (if any)
TRC detection algorithm	Specifies the algorithm type to be used when detecting TRC sequence. If set to Tight the TRC detection algorithm is more restrict.	Normal, Tight	Normal	Customer determined
Function Tones detected	Specifies how many TRC tones can be detected after HLGt tone.	1 to 2	2	Customer determined

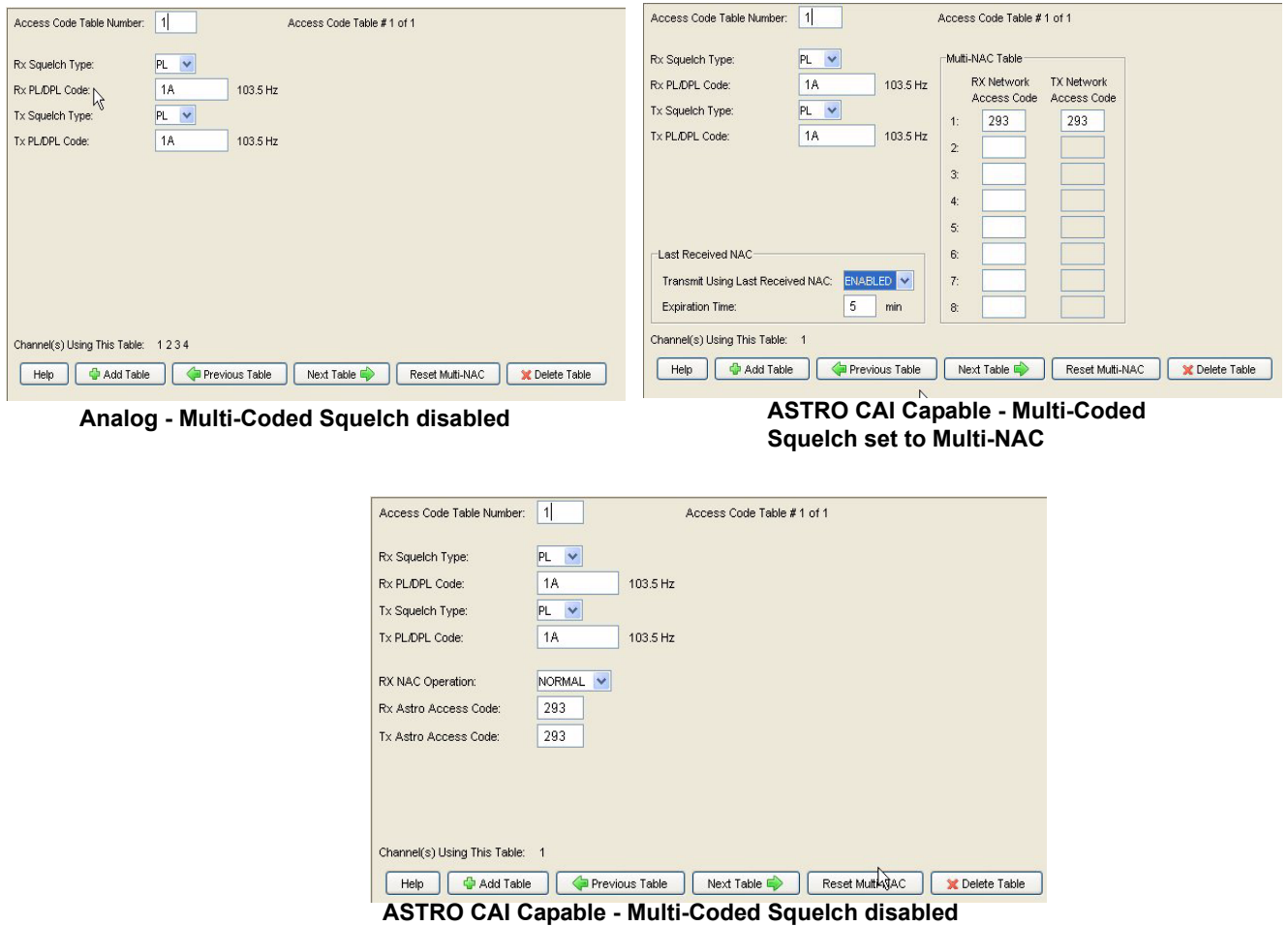
1. Enabling ALC affects the setting of the intercom volume immediately after a station reset. The intercom volume is high and may be unintelligible. The station requires one TRC sequence, such as high level guard tone/function tone sequence, in order to properly establish line levels. Therefore, before using intercom, request that the console send any TRC sequence to the station. This sequence establishes the proper level for intercom.

**Table 3-5** ASTRO Tab Parameters

Data Field	Description	Range/ Selections	Default	Recommended Setting (if any)
Wireline Interface	Defines type of ASTRO wireline interface as follows: <ul style="list-style-type: none"> <li>• V.24 Hybrid: Used for mixed mode, analog, and ASTRO systems, where the V.24 interface is used for ASTRO and control, and the Line 1/Line 2 wirelines are used for analog. Used only in trunked systems.</li> <li>• Modem: Used for systems where the external connections to/from stations are through phone lines. Used for mixed mode, analog, and ASTRO systems. Not used in trunking systems.</li> <li>• V.24 Only: Used for ASTRO only systems where the external connection is either local or through microwave link.</li> </ul>	<ul style="list-style-type: none"> <li>• V.24 Hybrid</li> <li>• Modem</li> <li>• V.24 Only</li> </ul>	<ul style="list-style-type: none"> <li>• Trunking: V.24 Hybrid</li> <li>• Conventional: Modem</li> </ul>	Customer determined
External Transmit Clock	Specifies whether external synchronization is required for transmit signal. Typically in installations where station and console are connected through a microwave link. RS232 Wireline Interface is used.	<ul style="list-style-type: none"> <li>• Enabled</li> <li>• Disabled</li> </ul>	Disabled	Customer determined
Analog Idle Link Check	Serves as diagnostic tool for V.24 Hybrid links to check the physical state of the links.	<ul style="list-style-type: none"> <li>• Enabled</li> <li>• Disabled</li> </ul>	Disabled	Customer determined
Digital Idle Link Check	Serves as diagnostic tool for all types of links to check the physical state of the links.	<ul style="list-style-type: none"> <li>• Enabled</li> <li>• Disabled</li> </ul>	Disabled	Customer determined
Modem Input Level (Tx WL)	Specifies the signal level range being input to ASTRO modem.	0 to -28 dBm or -9 to -37 dBm	0 to -28 dBm	Depends on system configuration
Modem Output Level (Rx WL)	Specifies the signal level being output from ASTRO modem.	0 to -20 dBm	-14 dBm	Depends on system configuration
RT/RT Configuration	If enabled, allows back-to-back connection of ASTRO stations in RF link configurations.	<ul style="list-style-type: none"> <li>• Enabled</li> <li>• Disabled</li> </ul>	Disabled	Customer determined

# Programming the Access Code Table Data For Conventional Systems

The appearance of the **Access Code Table** screen is dependent on the **Station Type** as configured in the **Hardware Configuration** screen. Click **Access Code Table** in the navigation pane to access the **Access Code Table** screen as shown in Figure 3-6.



**Figure 3-6** Access Code Table Screens

Up to 16 Access Code Tables may be created to provide flexibility in the system design, accommodating a variety of console and talkgroup combinations. The number of Access Code Tables you create and the information programmed into each depends on the system design. You may choose to create one access table for each channel or allow multiple channels to share the same table. When you program the **Channel Information** screen (see “Programming the Channel Information Screen” on page 3-20) you assign a particular **Access Code Table** number (in the **Active Code Table** field) to each channel provided by the station.

**NOTE**

The number of channel information screens you create and the information programmed into each depends on the system design.

Before programming the information in the Access Code Table(s), obtain the channel and access code information from the system designer. This information defines the number of channels supported by the station and the particular squelch type, PL/DPL codes or ASTRO codes to assign to each channel. Table 3-6 provides information about the Access Code Table parameters.

**Table 3-6** Access Code Table Field Definitions

Data Field	Description	Range/Selection	Default	Recommended Setting (if any)
Access Code Table Number	Identifies the current table as one of 16 possible tables.	1-16	1	N/A
Rx Squelch Type	Defines the type of receiver squelch recognized by station receiver.	<ul style="list-style-type: none"> <li>• PL</li> <li>• DPL</li> <li>• CSQ</li> </ul>	CSQ	Depends on system design
Rx PL/DPL Code	Defines the access code corresponding to PL or DPL type specified above.	Use Help screen or refer to tables in Appendix A of this guide	CSQ	Must be valid code for selected type (PL or DPL). PL codes typically below 200 Hz
Tx Squelch Type	Defines the type of sub-audio tone transmitted by station.	<ul style="list-style-type: none"> <li>• PL</li> <li>• DPL</li> <li>• CSQ</li> </ul>	CSQ	Depends on system design
Tx PL/DPL Code	Defines the access code corresponding to PL or DPL type specified above.	Use Help screen or refer to tables in Appendix A of this guide	CSQ	Must be valid code for selected type (PL or DPL). PL codes typically below 200 Hz
Digital Carrier Squelch	Specifies whether or not the RX ASTRO Access Code is used to qualify RX Audio. When enabled, all access codes are accepted and repeated audio goes out with Access Code 293.	<ul style="list-style-type: none"> <li>• Enabled</li> <li>• Disabled</li> </ul>	Disabled	Depends on system design
Rx ASTRO Access Code <sup>1</sup>	Defines receive ASTRO Network ID (in hex).	000-FFF	293	Depends on system design
Tx ASTRO Access Code <sup>1</sup>	Defines receive ASTRO Network ID (in hex).	000-FFF	293	Depends on system design
Channels Using This Table	Identifies channel number(s) of station channels that use current access code table.	1-256	1	Status only (non-editable)
Last Received NAC <sup>2</sup>	Determines whether the station transmits using the last received NAC.	Enabled Disabled	Disabled	Depends on system design
Last Received NAC Expiration Time	Accessible only when Last Received NAC is enabled. The timer defines how long the last RX NAC is used for transmissions after the last received call. Each received call restarts the timer.	1-30 minutes	5 minutes	Depends on system design
Multi-NAC Table <sup>2</sup>	Defines up to eight Rx and Tx network access codes for the specified Access Code Table Number. For ASTRO CAI voice only.	0-FFF (hex)	Rx No. 1 = 293 Tx No. 1 = NULL	Depends on system design

1. Applicable for ASTRO CAI Capable stations and Multi-Coded Squelch is disabled in the Hardware Configuration screen.
2. Applicable for ASTRO CAI Capable stations and Multi-Coded Squelch is set to Multi-NAC in the Hardware Configuration screen.

# Programming the Access Code Table Data for 6809 Trunking Systems

The 6809 trunking systems require that the subscribers and the stations be programmed with the same system Connect Tone.

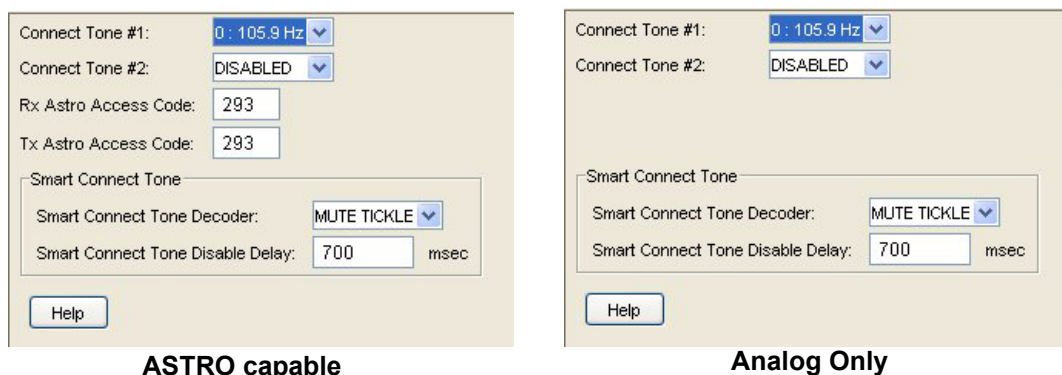


Figure 3-7 Access Code Table Screens

Table 3-7 Access Code Table Screen Parameters

Data Field	Description	Range/ Selections	Default	Recommended Setting (if any)
Connect Tone #1	Specifies one of eight frequencies to be used as connect tone #1 by the station.	0 through 7	0	Determined by system configuration
Connect Tone #2	Specifies one of the eight frequencies to be used as connect tone #2 by the station.	0 through 7	0	Determined by system configuration
Rx ASTRO Access Codes <sup>1</sup>	Defines receive ASTRO network ID (hex).	000-FFF (hex)	293	Depends on system design
Tx ASTRO Access Codes <sup>2</sup>	Defines transmit ASTRO network ID (hex).	000-FFF (hex)	293	Depends on system design
Smart Connect Tone Decoder	Specifies one of the two methods of minimizing time between subscriber request for service and conversation heard by receiving subscribers.	<ul style="list-style-type: none"> <li>Mute Tickle</li> <li>Unsquelled</li> <li>Disabled</li> </ul>	Mute Tickle	Customer determined
Smart Connect Tone Disable Delay	If Smart Connect Tone Decoder is enabled, it specifies the amount of time allowed for 6809 controller and station to detect connect tone before dropping the call.	0-1000 msec	700 msec	Customer determined

1. Rx ASTRO Access Code fields are displayed only if the station type is set as ASTRO capable in the Hardware Configuration screen.
2. Tx ASTRO Access Code fields are displayed only if the station type is set as ASTRO capable in the Hardware Configuration screen.

## Programming the Multi-Coded Squelch Table Screen

The multi-coded squelch feature is typically used to allow the station to serve as a community repeater and allows you to track subscriber access for billing purposes. The **Multi-Coded Squelch Table** screen is only accessible when the following settings, on the **Hardware Configuration** screen, are true:

- **Multi-Coded Squelch** field is Multi-PL Only
  - **System Type** is Conventional
  - **Station Type** is Analog Only

When these conditions are not met, the **Access Code Table** screen is accessible.



### NOTE

For accurate billing information to be available, configure the station's date and time as outlined in "Setting the Device's Date and Time" on page 3-8.

Station Serial Number: 448CAX0252    Station Date: / /  
 Station Time: : : :

**User Tables**

#	Rx Type	Rx Freq/Code	Tx Type	Tx Freq/Code	User Access	Total Time Used	Number of Calls
1	PL	103.5 1A	PL	103.5 1A	ENABLED	: :	: :
2						: :	: :

**Figure 3-8** Multi-Coded Squelch Table Screen

Subscriber radios are identified by their PL or DPL code and their usage time is logged and saved in station memory. This information may be retrieved, displayed, and saved as a text file for printing or incorporating into a report. This type of information is typically used for billing or other accounting purposes.

On the initial access of the **Multi-coded Squelch Table** screen, a default **User #1** appears with the default data. The **Total Time Used** and **Number of Calls** fields are empty. From this initial screen, up to 13 total users may be entered (12 PL and 1 DPL). When finished, the information is saved to the station codeplug.

When the station is placed into service and users begin placing calls, their usage time is monitored and stored in station non-volatile memory. The RSS allows access to this information for display and saving to a text file.





## NOTE

Multi-coded squelch is allowed on only one channel.

To retrieve the multi-coded squelch information, such as usage time, you must read the codeplug from the station.

## Saving User Information

To save multi-coded squelch user data information such as usage times and number of calls, you must first read the codeplug from the station. However, the information is not saved with the codeplug data when the codeplug is saved to an archive file.

To save the multi-coded squelch (MCS) information, click **Save Report** as shown in Figure 3-9. A browser window appears, allowing you to browse to the desired directory and provide a name for the multi-coded squelch data file.



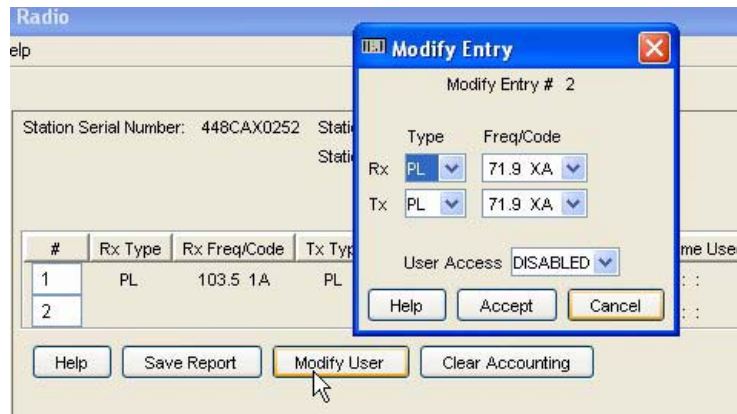
**Figure 3-9** Save Report Button to Save MCS Data

## Adding New Users

To add new users, perform the following procedure:

1. Click **Multi-Coded Squelch Table** in the navigation pane.
2. Click the last number in the list (at the blank line) so that the cursor blinks in the number's cell (it is non-editable).

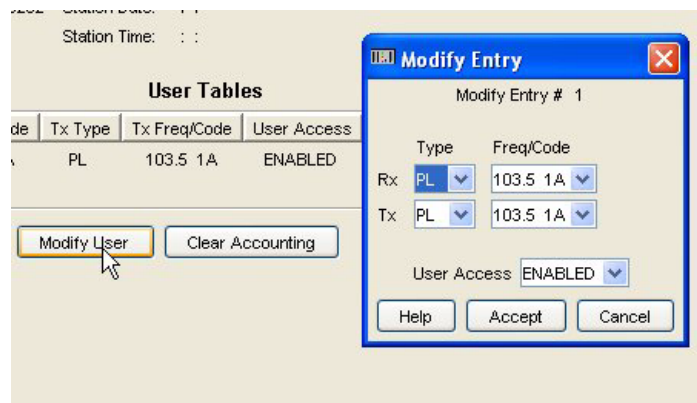
3. Click **Modify User**. The Modify Entry window appears for that user.
4. Enter the settings as appropriate.



5. Click **Accept** to save the data. The new user is added to the list and also the next user number is added.

## Modifying an Existing User

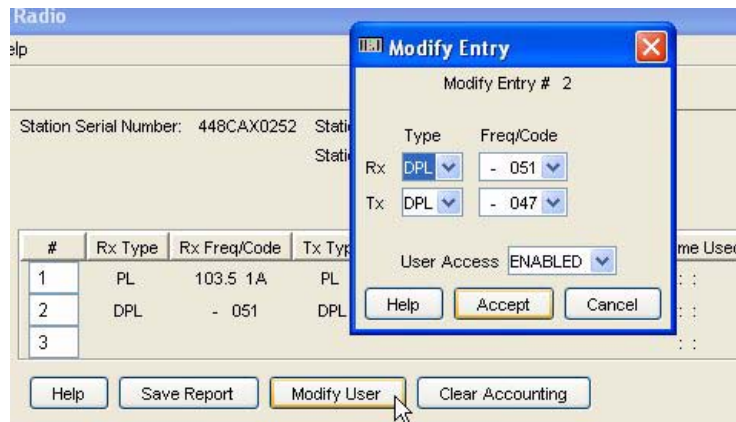
1. Click **Multi-Coded Squelch Table** in the navigation pane.
2. Click the number of the user you need to modify so that the cursor blinks in the number's cell (it is non-editable).
3. Click **Modify User**. The Modify Entry window appears for that user.



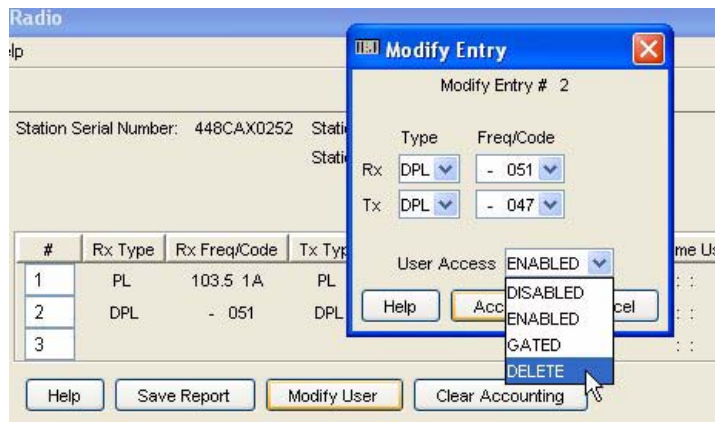
4. Modify the settings as required.
5. Click **Accept** to save the user data or **Cancel** to exit without saving.

## Deleting an Existing User

1. Click **Multi-coded Squelch Table** in the navigation pane.
2. Click the number of the user to be deleted so that the cursor blinks in the number's cell (it is non-editable).
3. Click **Modify User**. The Modify Entry window appears for that user.



4. Select **Delete** from the User Access selection list.



5. Click **Accept**. The User Table indicates the User Access as DELETE.

#	Rx Type	Rx Freq/Code	Tx Type	Tx Freq/Code	User Access	T
1	PL	103.5 1A	PL	103.5 1A	ENABLED	
2	DPL	- 051	DPL	- 047	DELETE	
3						

The current usage time and number of call data for the deleted users is erased when the codeplug is uploaded to the station.

## Programming the Channel Information Screen

The **Channel Information** screen allows you to specify frequencies, operating parameters, and time-out timer settings for each channel supported by the station. Up to 16 channels may be created with the data fields for each channel contained on two screen pages.

The number of channel information screens you create and the information programmed into each depends on the system design. Before programming the information in the Channel Information screen(s), obtain the channel and access code information from the system designer. This information, typically recorded in a system design document, defines the number of channels supported by the station and the particular frequencies, timer settings, and other system parameters applicable to the station. See Figure 3-10 and Figure 3-11 for the Channel Configuration screens.

The screenshot shows the 'Channel Configuration Screen' for 'CHANNEL# 1 of 4'. The 'Basic' tab is selected. The 'Channel Number' is set to 1. The 'Rx1 Frequency' is 806.200000 MHz, 'Tx Frequency' is 851.200000 MHz, 'Rx2 Frequency' is 0.000000 MHz, and 'Tx Idle Frequency' is 851.012500 MHz. The 'Modulation Type' is set to 'ANALOG'. The 'Tx Rated Deviation' is 5.000 kHz. The 'Receive Channel BW' is 'VMDE 25-30' kHz Channel Spacing. The 'Call Sign' is 'KGA647' and 'Call Sign Over Wireline' is 'DISABLED'. The 'Access Code Table' is 1. The 'Carrier Squelch Transition' is 'NORMAL'. The 'Analog Rx Activation' is 'SC=Carrier and PL/DPL'. The 'Analog Rptr Activation' is 'SC=Carrier and PL/DPL'. The 'Analog Rptr Hold-In' is 'C=PL/DPL'. The 'Analog Rptr Access' is 'NONE'. At the bottom, there are buttons for 'Help', 'Add Channel', 'Previous Channel', 'Next Channel', and 'Delete Channel'.

**Figure 3-10** Channel Configuration Screen

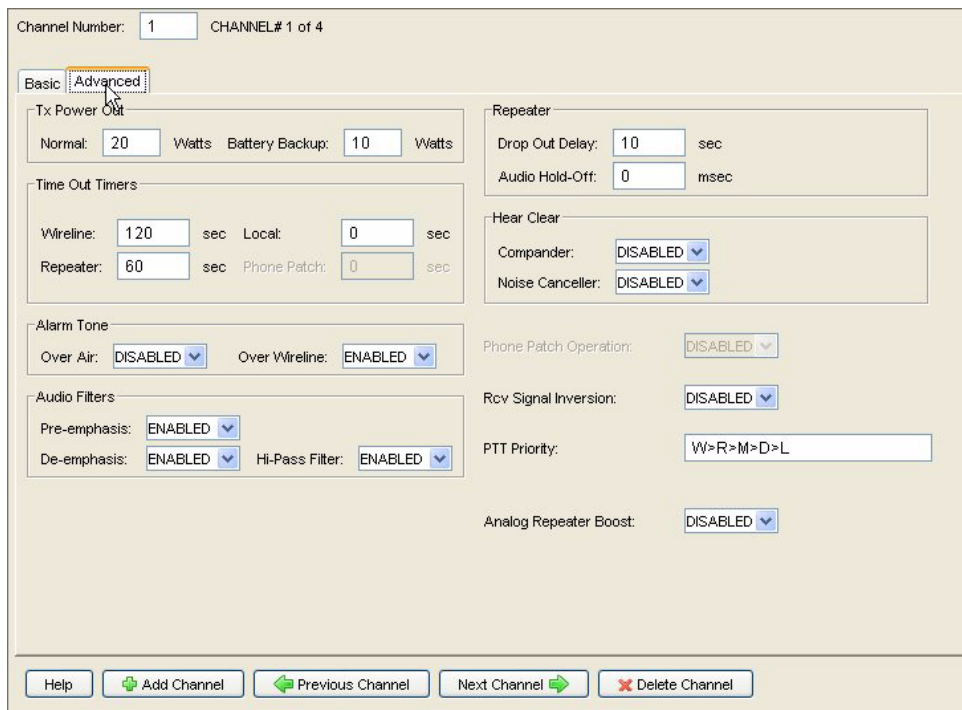


Figure 3-11 Advanced Channel Information Screen


Table 3-8 Channel Configuration Field Definitions

Data Field	Description	Range/Selection	Default	Recommended Setting (if any)
Channel Number	Identifies the current channel as one of 16 possible channels.	1-16	1	N/A
Rx1 Frequency and Rx2 Frequency	Receive frequency in MHz for current channel for Receiver #1 or Receiver #2.	Depends on band	N/A	Frequency assigned by FCC (depends on system design).
Tx Frequency	Transmit frequency in MHz for current channel.	Depends on band	N/A	Frequency assigned by FCC (depends on system design). Set to "0" to disable transmitter.
Tx Idle Frequency <sup>1</sup>	Defines frequency the transmit oscillator tunes to when not transmitting.	Depends on band	N/A	N/A
Modulation Type	Specifies the type of modulation for current channel.	<ul style="list-style-type: none"> <li>Analog/ASTRO</li> <li>ASTRO or Analog</li> <li>Analog/SECURENET CFS</li> <li>Analog/SECURENET XL</li> <li>SECURENET CFS</li> <li>SECURENET XL</li> <li>ASTRO CAI</li> <li>Analog/ASTRO CAI</li> </ul>	Analog	Depends on system design.
Tx Rated Deviation	Specifies the maximum frequency deviation allowed for channel.	<ul style="list-style-type: none"> <li>5.00 kHz</li> <li>4 kHz</li> <li>2.5 kHz</li> </ul>	5.00 kHz	Determined by FCC per channel type. Depends on system design.

**Table 3-8** Channel Configuration Field Definitions (continued)

Data Field	Description	Range/Selection	Default	Recommended Setting (if any)
Receive Channel BW	Specifies the frequency spacing (in kHz) between channels.	<ul style="list-style-type: none"> <li>Wide (25-30 kHz)</li> <li>NPSpac (25 kHz)</li> <li>Narrow (12.5-15 kHz)</li> <li>Narrow (12.5 KHz)</li> </ul>	Wide	Determined by FCC per channel. Depends on system design.
Call sign	Specifies the call sign for station. Assigned by FCC.	Alphanumeric (15 characters max)	N/A	Assigned by FCC. Depends on system design.
Call Sign Over Wireline	Determines whether call sign is sent to console over wireline.	<ul style="list-style-type: none"> <li>Enabled</li> <li>Disabled</li> </ul>	Disabled	Customer defined.
Access Code Table	Specifies which of the 256 possible access code tables applies to current channel.	0-16 (0 = none)	1	Depends on system design.
Carrier Squelch Transition	This provides two threshold selections: Normal and Shifted. Normal operation sets squelch performance so that the receiver unsquelches in 20 ms for signals above squelch set level and 180 ms for signals below squelch set level but above receiver sensitivity. Shifted operation sets squelch performance so that the receiver unsquelches in 20 ms for signals above 1 uV and unsquelches in 180 ms for signals below 1 uV but above the receiver sensitivity.	<ul style="list-style-type: none"> <li>Normal</li> <li>Shifted</li> </ul>	Normal	Customer defined.
Analog Rx Activation	Specifies the type of squelch required to unsquelch receiver.	<ul style="list-style-type: none"> <li>Off</li> <li>S = Carrier Squelch</li> <li>C = PL/DPL</li> <li>SC = Carrier and PL/DPL</li> <li>On = Unsquelched</li> </ul>	Off	Customer defined. See help for details. Depends on system design.
Analog Repeater Activation	Specifies the type of squelch required to activate repeater.	<ul style="list-style-type: none"> <li>Off</li> <li>S = Carrier Squelch</li> <li>C = PL/DPL</li> <li>SC = Carrier and PL/DPL</li> <li>On = Unsquelched</li> </ul>	Off	Customer defined. See help for details. Depends on system design.
Analog Repeater Hold-In	Specifies the type of squelch required to maintain repeater activation.	<ul style="list-style-type: none"> <li>Off</li> <li>S = Carrier Squelch</li> <li>C = PL/DPL</li> <li>SC = Carrier and PL/DPL</li> <li>On = Unsquelched</li> </ul>	Off	Customer defined. See help for details. Depends on system design.
Analog Repeater Access	Specifies whether repeater is activated by carrier detect/PL - DPL detect or subscriber-generated tone (DTMF, MDC preamble, or Singletone). If set for MDC/Tone, SAM board must be programmed with corresponding tones.	<ul style="list-style-type: none"> <li>None</li> <li>MDC/Tone</li> </ul>	None	Customer defined. See help for details. Depends on system design.
Tx Power Out	Specifies the output power from the station power amplifier module. This field is limited to a pre-determined output power level if the station is equipped with the Limited Output Power option.	Approximately 50% to 110% (Quantro) or 25% to 110% (QUANTAR) of PA rating.	Value entered in Channel Configuration screen.	Refer to system design document for FCC licensed power rating.

**Table 3-8** Channel Configuration Field Definitions (continued)

Data Field	Description	Range/Selection	Default	Recommended Setting (if any)
 <b>IMPORTANT</b> When setting the output power on a QUANTAR station with high power booster, divide the desired station output power by 18.75 and enter this value in the TX Power Out field. For example, to set the station's maximum output power to 300W, enter a value of 16 (300 ÷ 18.75). The output power appears with ±7% of the desired value. Do not set the VHF station power amplifier modules to greater than 18 W, or 800 MHz station power amplifier modules to greater than 16W.				
Battery Backup	Specifies the output power from the station power amplifier module when in battery backup mode. Refer to the Important note in Tx Power Out.	Approximately 50% to 110% (Quattro) or 25% to 110% (QUANTAR) of PA rating.	50% of value entered in Channel Configuration screen.	Customer defined. Set to lower value to extend station operation in battery backup mode.
<b>Time Out Timers:</b>				
Wireline	Specifies the maximum amount of time transmitter may be continuously activated by console through wireline.	0-2550 seconds (0 = disabled)	120 sec	Customer defined
Local	Specifies the maximum amount of time transmitter may be continuously activated by local microphone/handset.	0-2550 seconds (0 = disabled)	0 sec	Customer defined
Repeater	Specifies the maximum amount of time repeater mode may be continuously activated by subscriber through receiver.	0-2550 seconds (0 = disabled)	0 sec	Customer defined
MRTI	Specifies the time a user may retain MRTI interface by holding PTT before system cancels transmission.	0-2550 seconds (0 = disabled)	0 sec	Customer defined
<b>Alarm Tone:</b>				
Over Air	Specifies whether station alarm tones (four total) are transmitted over air.	<ul style="list-style-type: none"> <li>• Enabled</li> <li>• Disabled</li> </ul>	Disabled	Customer defined
Over WL	Specifies whether station alarm tones (four total) are transmitted over wireline to console.	<ul style="list-style-type: none"> <li>• Enabled</li> <li>• Disabled</li> </ul>	Disabled	Customer defined
<b>Audio Filters:</b>				
Pre-emphasis	Specifies whether analog audio is passed through internal +6 dB per octave slope filter prior to transmission.	<ul style="list-style-type: none"> <li>• Enabled</li> <li>• Disabled</li> </ul>	Enabled	Customer determined
De-emphasis	Specifies whether analog audio is passed through internal -6 dB per octave slope filter prior to transmission.	<ul style="list-style-type: none"> <li>• Enabled</li> <li>• Disabled</li> </ul>	Enabled	Customer determined
Hi-pass Filter	Specifies whether analog audio is passed through internal 300 Hz corner high pass filter. Filters PL or DPL low-frequency signaling.	<ul style="list-style-type: none"> <li>• Enabled</li> <li>• Disabled</li> </ul>	Enabled	Customer determined
<b>SECURENET:</b>				
WL CSQ Mute Timer	This parameter is used when the channel is configured for SECURENET and Rx Activation is set to CSQ to specify the time that RX Audio is gated to the wireline after carrier is detected.	0-1000 msec	150 msec	Customer determined

**Table 3-8** Channel Configuration Field Definitions (continued)

Data Field	Description	Range/Selection	Default	Recommended Setting (if any)
<b>Repeater:</b>				
Drop Out Delay	Specifies the amount of time repeater mode is maintained following loss of received signal.	0-2550 sec	2 sec	Customer defined. Typically 1 to 5 sec.
Audio Hold-Off	Specifies the amount of delay before receive audio is gated to the transmitter in repeater applications.	0-2550 msec	0 msec	Customer defined. Typically used in systems with subscriber MDC ID to prevent ID from being repeated.
<b>Hear Clear:</b>				
Compander	Determines whether companding (compression and expansion) is employed for transmit/receive signals.	<ul style="list-style-type: none"> <li>• Disabled</li> <li>• Enabled</li> </ul>	Disabled	Customer determined
Noise Canceller	Determines whether receiver noise cancellation is employed.	<ul style="list-style-type: none"> <li>• Disabled</li> <li>• Enabled</li> </ul>	Disabled	Customer determined
<b>Advanced:</b>				
MRTI Operation	Specifies whether MRTI (phone patch) feature is enabled or disabled for this channel.	<ul style="list-style-type: none"> <li>• Disabled</li> <li>• Enabled</li> </ul>	Disabled	Customer determined
Receive Signal Inversion	Allows polarity of receive signal to be inverted.	<ul style="list-style-type: none"> <li>• Disabled</li> <li>• Enabled</li> </ul>	Disabled	Customer determined
PTT Priority	<p>Specifies priority order of three types of PTT requests:</p> <ul style="list-style-type: none"> <li>• W = wireline</li> <li>• R = repeater</li> <li>• L = local</li> </ul> <p>Examples:</p> <ul style="list-style-type: none"> <li>• W &gt; R: Wireline has priority over repeater</li> <li>• R = L: Repeater and local PTT requests have equal priority. Whichever occurs first takes and maintains PTT control.</li> </ul>	See help	W > R > L	Customer defined
Analog Repeater Boost	<p>Specifies whether received signal is boosted prior to transmission by repeater. Boost = 150% (3 dB)</p> <p><b>Example:</b> 2 kHz deviation receive signal is repeated at 3 kHz deviation.</p>	<ul style="list-style-type: none"> <li>• Enabled</li> <li>• Disabled</li> </ul>	Enabled	Customer defined

1. If Tx and Rx frequencies are different (as in repeater application), the Tx idle frequency equals the Tx frequency. If the Rx and TX frequencies are equal (as in base station application), the Tx idle frequency is set to a value derived by the following formula: If Tx = Rx and the frequency is divisible by 6.25 kHz with no remainder, then Tx idle = (Tx frequency - 112.5 kHz). Result must be higher than lower limit for band or range. If less than lower limit, Tx idle frequency is calculated as follows: Tx Idle = Tx Frequency + 112.5 kHz. If Tx = Rx and is not divisible by 6.25 kHz, Tx idle is calculated using previous two formulas with 112.5 kHz replaced with 90 kHz. If you change either the Rx or Tx frequency and it results in making the two frequencies equal, a pop-up window appears providing you with the opportunity to let the RSS program calculate the proper Tx idle frequency.



## Programming the TRC Commands Data

The QUANTAR stations installed in conventional systems are capable of being controlled from a remote console through function tones transmitted over the wireline when the Wireline option is set to the installed wireline module (other than None). The station is capable of detecting a high level guard tone (HLGT) and up to 17 different function tones. Up to eight commands can be associated with the HLGT and each of the 17 function tones. The commands associated with a particular tone are queued for execution after that tone is detected. The station decodes up to two function tones after HLGT is detected.

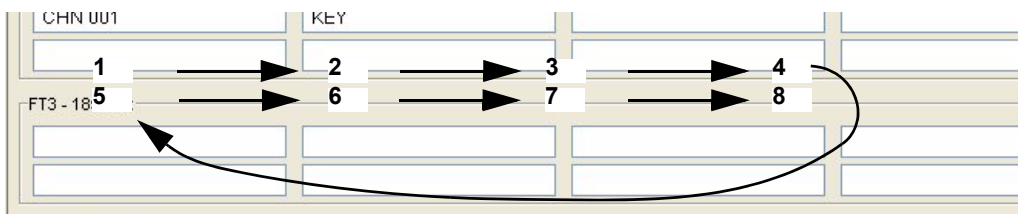
Program the function tones as directed by the system designer, as follows:

1. Click **TRC Command Table** in the navigation pane. The TRC Command Table screen appears as shown in Figure 3-12. The TRC Commands screen allows you to define any or all of the 18 function tones by assigning up to eight station commands per tone.

Guard Tone - 2175 Hz			
MORE			
FT1 - 2050 Hz			
MONITOR			
FT2 - 1950 Hz			
CHN 001	KEY		
FT3 - 1850 Hz			
FT4 - 1750 Hz			
FT5 - 1650 Hz			
FT6 - 1550 Hz			

**Figure 3-12** TRC Command Table Screen

1. Click **the cursor in the desired** field to start entering commands through the keyboard. The commands are executed in sequence.



- For any displayed tone in the TRC Command Table screen: Enter the desired command from Table 3-9 in the cells of that tone, up to eight commands per tone.



**NOTE**

If the Guard tone is set to a frequency that is within 40 Hz of a function tone, that function tone is blanked and therefore unavailable for use.

- Repeat step 2 for all other tones, if required.

**Table 3-9** TRC Commands

Command	Function
ALARM OFF	Commands station not to route alarm alert tones (over the air and/or over the wireline, as defined on the Channel Information screen.
ALARM ON	Commands station to route alarm alert tones (over the air and/or over the wireline, as defined on the Channel Information screen.
CHN XXX	Commands station to tune transmitter and receiver to specified channel. The channel must exist on the Channel Information table. Example: CHN 002.
GATEACC OFF	Commands station not to repeat for users with PLs/DPLs assigned with a User Access of Gated on Multi-Coded Squelch screen.
GATEACC ON	Commands station to repeat for users with PLs/DPLs assigned with a User Access of Gated on Multi-Coded Squelch screen.
KEY	Commands station to key transmitter and remain keyed as long as low level guard tone is received. If a KEY command is queued by the first tone detected, all subsequent tones and their associated commands are ignored until the detection of a subsequent high level guard tone.
KEY ON	Commands station to key transmitter indefinitely. Transmitter may be de-keyed by the KEY OFF command.
KEY OFF	Commands station to de-key transmitter.
MONITOR	Commands station to turn on receiver-to-wireline audio path. Overrides all squelch requirements, if any.
MORE	Not required for QUANTAR/Quantro stations. See Help for details.
MRTI OFF	Disables MRTI (phone patch) feature. MRTI is enabled at station boot.
MRTI ON	Enables MRTI (phone patch) feature capability. Used to cancel MRTI OFF command.
RXPL ON	Commands station to turn on appropriate receiver squelch (as programmed in Channel Information screen for the affected channel). Includes CSQ, PL, and DPL.
RXPL OFF	Commands station to turn off appropriate receiver squelch (as programmed in Channel Information screen for the affected channel). Includes CSQ, PL, and DPL.
RPT ON	Enables repeater mode (if repeater capable). Station repeats when qualifiers, as programmed in analog Rx Activation field in the Channel Information screen, are met.
RPT OFF	Disables repeater mode (if repeater capable). Station repeats when qualifiers, as programmed in analog Rx Activation field in the Channel Information screen, are met.

**Table 3-9** TRC Commands (continued)

Command	Function
SCAN ON	Commands station to begin receiver scanning operation, beginning with first scan-enabled channel in the Channel Scan List. This requires purchase of Scanning Receiver option.
SCAN OFF	Commands station to cease receiver scanning operation. Station remains on the current channel.
SCAN RESUME	If receiver scanning has been suspended, this command causes the station to resume receiver scanning operation.
SCAN SUSPEND	If station is in receiver scanning operation, this command stops the scanning process and places the station on the current channel.
SELALARM OFF	Commands station to stop sending alarm alert tones for current active alarm over the air and/or over the wireline, as defined on the Channel Information screen. Alarm alert tones for any subsequent alarms are routed normally.
SELALARM ON	Cancels SEALARM OFF command. If SEALARM OFF had been used to silence the alarm alert tones for a currently active alarm, issuing the SEALARM ON command allows the tones to be routed normally over the air and/or over the wireline, as defined on the Channel Information screen.
TXPL ON	Commands station to turn on appropriate transmitter squelch code as programmed in Channel Information screen for the affect channel. Includes CSQ, PL, and DPL.
TXPL OFF	Commands station to turn off appropriate transmitter squelch code as programmed in Channel Information screen for the affect channel. Includes CSQ, PL, and DPL.
WAIT XXXXX	Commands station to wait XXXXX msec before executing the next command. Range is 0-10000 (10 sec).

## Programming DC Remote Command Data

QUANTAR and Quantro stations in conventional systems are capable of being controlled by a remote console through a DC current level when:

- Remote Control Type (on Wireline Configuration screen) is set to DC.
- Wireline Option (on Hardware Configuration screen) is set to any valid wireline configuration in the selection list.

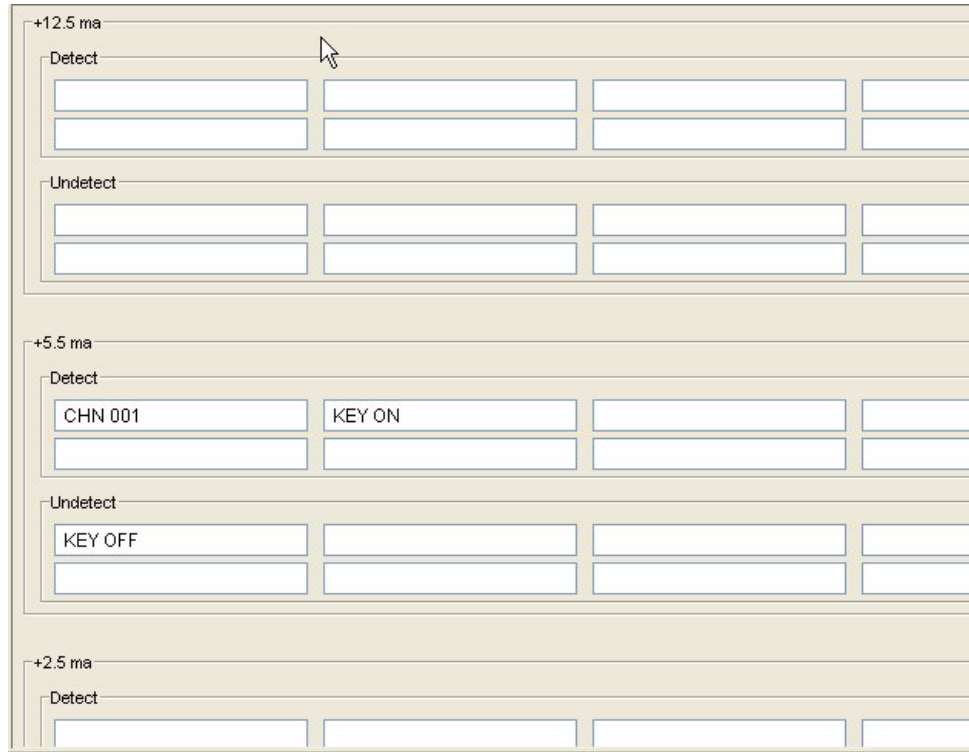
The station contains decoder circuitry that can interpret detection and undetection of up to six DC current levels:

- +12.5 mA
- +5.5 mA
- +2.5 mA
- -12.5 mA
- -5.5 mA
- -2.5 mA

Each current level may represent up to eight station commands that are performed sequentially by the station. The DC Commands screen allows you to define any or all of the six DC currents, in both Detect and Undetect states, by assigning up to eight station commands per current level. When the tone is generated by a tone remote console, the commands are performed in sequence.

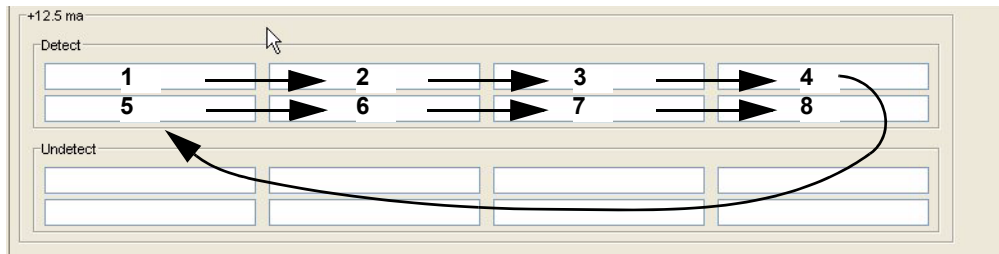
Program the DC remote command data as directed by the system designer, as follows:

1. Click **DC Command Table** in the navigation pane. The DC Configuration Table screen appears (Figure 3-13).



**Figure 3-13** DC Command Table Screen

2. Click **the cursor in the desired field** to start entering commands through the keyboard.



3. For any displayed tone in the DC Command Table screen, enter the desired command from Table 3-9 in the cells for that current level (up to six commands per current level). Repeat step 2 for all other current levels, if required.



**NOTE**

The only command that does not apply to DC Remote Commands Data is KEY.

# Programming the RF Configuration Data Screen

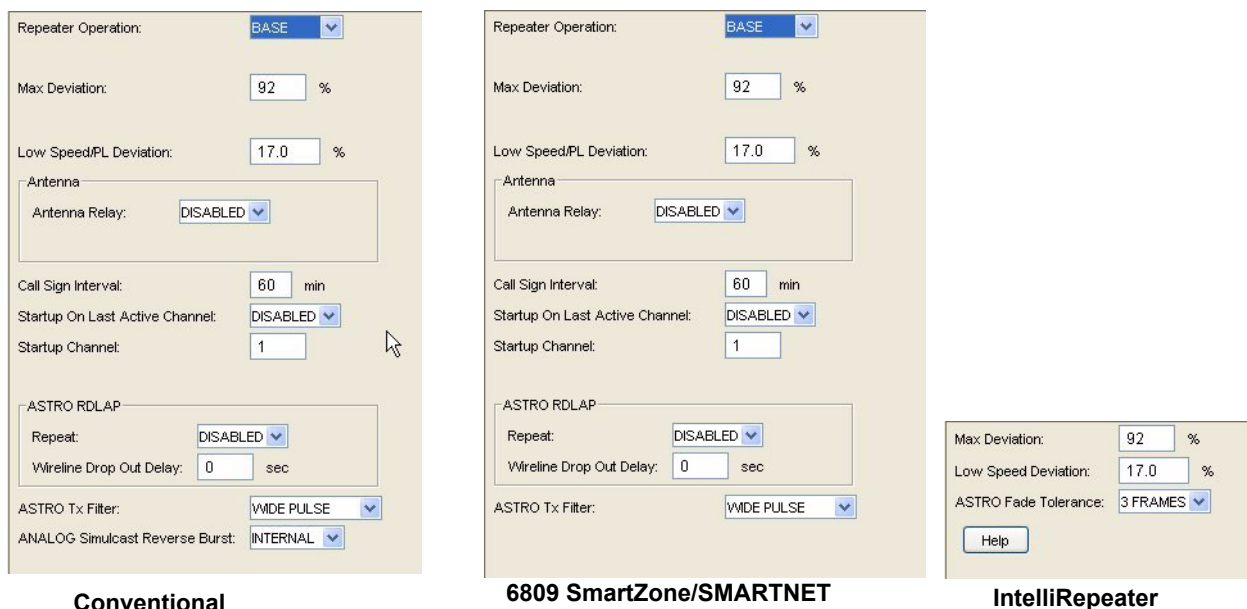
The RF Configuration screen allows you to specify operating parameters and system timing values for the station. The default values programmed into this screen at the factory represent standard typical values, and in most cases, need not be changed. However, all fields are fully editable to accommodate unique system requirements or user-specified values.



## NOTE

Not applicable to DSIII or QUANTAR data base stations.

Click **RF Configuration** in the navigation pane to access the applicable RF Configuration screen (see Figure 3-14). See Table 3-10 for details on each field.



**Figure 3-14** RF Configuration Screens

**Table 3-10** RF Configuration Data Fields

Data field	Description	Range/ Selection	Default	Recommended Setting (if any)
Repeater Operation	Specifies whether station is operating as a base station or a repeater.	<ul style="list-style-type: none"> <li>Base</li> <li>Repeater</li> </ul>	Base	Depends on system design
Max Deviation	Limits the station transmit deviation to a percentage of maximum Tx Rated Deviation set on the Channel Information screen.	0-100%	92%	92% recommended

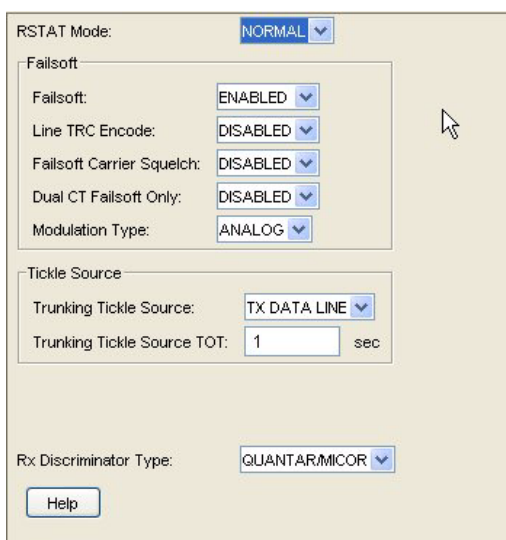
**Table 3-10** RF Configuration Data Fields (continued)

Data field	Description	Range/ Selection	Default	Recommended Setting (if any)
Low Speed/PL Deviation	Specifies the deviation for low speed TDATA for 6809 trunking applications.	0-25%	<ul style="list-style-type: none"> <li>17% for 25 kHz</li> <li>18% for 12.5 kHz</li> </ul>	17% or 18% recommended based on channel bandwidth
Antenna Relay	Specifies whether antenna relay is implemented on station.	<ul style="list-style-type: none"> <li>Disabled</li> <li>Enabled</li> </ul>	Disabled	N/A
Antenna Relay Delay	Specifies the delay to allow relay contacts to close before station transmitter is keyed.	30-90 msec	30 msec	30 msec recommended
Call Sign Interval	Specifies the time interval at which FCC assigned station call sign is broadcast.	1-60 minutes	10	Set time less than or equal to the time specified by the FCC
Startup on Last Active Channel	Specifies that the station starts on the last active channel after a reset.	<ul style="list-style-type: none"> <li>Disabled</li> <li>Enabled</li> </ul>	Disable	Depends on system configuration
Startup Channel	Specifies the channel to which station it is set after a reset. Ignored if Startup on Last Active Channel is enabled.	1-28	1	Depends on system configuration
ASTRO Fade Tolerance	Specifies the number of missed frames before ASTRO message is considered terminated.	1-3 frames	3 frames	Customer defined
Fast Key-Up	Specifies whether the Fast Key-Up feature is implemented between the station and external device. If enabled, station transmitter key-up time is shortened to 10-12 msec. See Fast Keyup Feature section in station manual for details.	<ul style="list-style-type: none"> <li>Disabled</li> <li>Wideband</li> <li>Aux Tx</li> </ul>	Disabled	Customer selected feature
<b>ASTRO RDLAP:</b>				
Repeat	Specifies whether RDLAP data is repeated.	<ul style="list-style-type: none"> <li>Disabled</li> <li>Enabled</li> </ul>	Enabled	Depends on system configuration
Wireline Drop Out Delay	Specifies the length of transmitter hang time following reception of last RDLAP data block.	0-255 sec	0 sec	Depends on system configuration
ASTRO Tx Filter	Affects signal shaping so that the transmitted audio occupies a 25 kHz (wide) or 12.5 kHz (narrow) channel.	<ul style="list-style-type: none"> <li>Wide Pulse</li> <li>Narrow Pulse</li> </ul>	Wide Pulse	Depends on system configuration. Coordinate with subscriber programming
Analog Simulcast Reverse Burst	Specifies whether reverse burst is generated internally by station or by external equipment. For conventional simulcast systems only.	<ul style="list-style-type: none"> <li>Internal</li> <li>External</li> </ul>	Internal	Depends on system configuration
<b>SECURENET:</b>				
Rx code Detect Fade Timer	Setting determines amount of time following a loss of Rx Data before EOM is sent and call is terminated. For example, due to signal fade.	0-9999 msec	80 msec	80 msec recommended
Fade EOM Timer	Setting determines length of EOM signal transmitted following expiration of the RX Code Detect Fade Timer.	0-9999 msec	80 msec	80 msec recommended

## Programming the 6809 Trunking Interface Data

The 6809 Trunking Interface screen allows you to specify operating parameters and system timing values for stations installed in 6809 trunking systems (as set in the System Type selection list). The default values programmed into this screen at the factory represent standard typical values, and in most cases, need not be changed. However, all fields are fully editable to accommodate unique system requirements or customer-specified values.

Click **6809 Trunking Interface** in the navigation pane to access the 6809 Trunking Interface screen (see Figure 3-15). See Table 3-11 for the screen’s data fields.



**Figure 3-15** 6809 Trunking Interface Screen

**Table 3-11** 6809 Trunking Interface Screen Data Fields

Data Field	Description	Range/Selections	Default	Recommended Setting (if any)
RSTAT Mode	Specifies the conditions for RSTAT to go active.	<ul style="list-style-type: none"> <li>Normal: receiver unsquelch</li> <li>Dual CT: dual connect tone (trunking)</li> </ul>	Normal	Depends on system configuration
Failsoft	Specifies whether station has ability to activate failsoft mode.	<ul style="list-style-type: none"> <li>Disabled</li> <li>Enabled</li> </ul>	Enabled	Customer determined
Line TRC Encode	Specifies whether station generates continuous tone (2175 Hz) down wireline when in failsoft mode.	<ul style="list-style-type: none"> <li>Disabled</li> <li>Enabled</li> </ul>	Disabled	Customer determined
Failsoft Carrier Squelch	Specifies whether station repeats on carrier squelch, instead of connect tones, when in failsoft mode.	<ul style="list-style-type: none"> <li>Disabled</li> <li>Enabled</li> </ul>	Disabled	Customer determined
Dual CT Failsoft Only	Specifies whether station requires dual connect tones, instead of single connect tone, when in failsoft mode.	<ul style="list-style-type: none"> <li>Disabled</li> <li>Enabled</li> </ul>	Disabled	Customer determined

**Table 3-11** 6809 Trunking Interface Screen Data Fields (continued)

Data Field	Description	Range/Selections	Default	Recommended Setting (if any)
Modulation Type	Specifies which voice mode is used while in failsoft mode.	<ul style="list-style-type: none"> <li>Analog</li> <li>ASTRO</li> </ul>	Analog	Depends on system configuration
Trunking Tickle Source	Specifies the signal source used to indicate whether 6809 central is functioning properly.	<ul style="list-style-type: none"> <li>TX Data Line</li> <li>Mute Line</li> </ul>	TX Data	Customer determined
Trunking Tickle Source TDT	Specifies the amount of time tickle source must be absent before station considers 6809 central malfunctioning.	1-72 sec	1	<ul style="list-style-type: none"> <li>If tickle source is TX Data, then one second is recommended</li> <li>If tickle source is Mute Line, then 72 sec is recommended</li> </ul>
CSC Logical Channel Number	Specifies the logical channel number to which this repeater is assigned.	1-32	1	Depends on system configuration
Rx Discriminator Type	Specifies the Rx Discriminator Audio characteristics for stations at a 6809 trunking site.	<ul style="list-style-type: none"> <li>QUANTAR/Micor</li> <li>MSF</li> </ul>	QUANTAR/Micor	Depends on system configuration

## Programming the Scan List Configuration Data

The channel scanning feature allows conventional stations and subscribers to continuously scan through a list of channels, looking for carrier activity. If a carrier is detected, the scanning process is suspended. When the carrier is no longer detected, the scanning process resumes.

Scanning may be programmed to start automatically on the station reset or under manual control from the console.

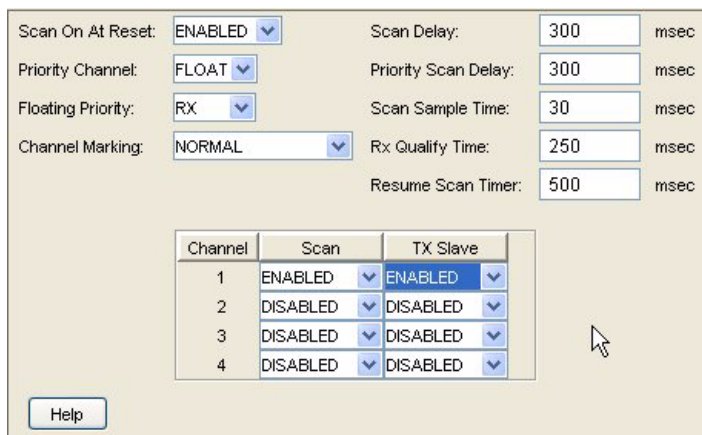


### NOTE

Scanning Receiver must be enabled on the Hardware Configuration screen.

The Scan List Configuration screen (Figure 3-16) provides the parameters necessary to determine the channels in the scanning list, set a priority channel, and to set timing periods related to channel scanning.





**Figure 3-16** Scan List Configuration Screen

In general, the data fields in the upper portion of the screen relate to scanning parameters that affect the overall scanning process. The lower portion of the screen is used to select the channels to be included in the scanning list and to determine which channels, if any, are to be used as repeater channels. To access the Scan List Configuration screen, click **Scan List Configuration** in the navigation pane. See Table 3-12 for the screen’s data fields.

The channels listed in the table (four are shown in Figure 3-16) are the available channels for the particular station. Use this table to enable or disable the scanning feature for the listed channel(s).

The data fields in the TX Slave column allow you to set one or more of the scanning channels to act as repeater channels. For example, when the scanning process detects a carrier on a scanning channel, the transmitter is keyed while locked on that channel.

**Table 3-12** Scan List Configuration Data Fields

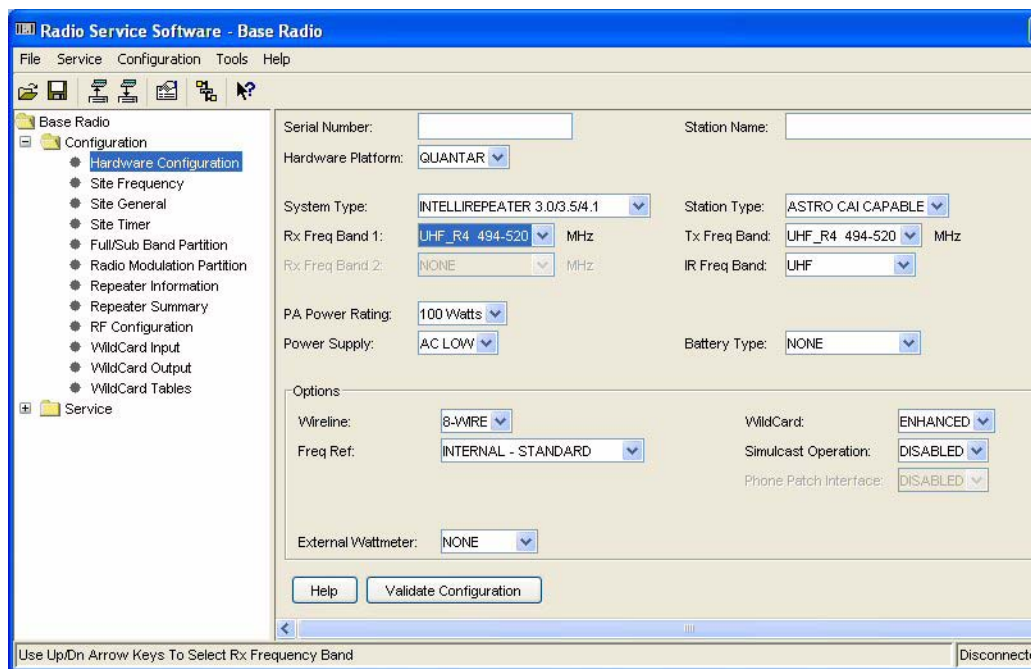
Data Field	Description	Range/ Selections	Default	Recommended Setting (if any)
Scan On At Reset	Specifies whether the station initiates the scanning process when reset.	<ul style="list-style-type: none"> <li>Enabled</li> <li>Disabled</li> </ul>	Disabled	Customer determined
Priority Channel	Specifies if any channel is used as a priority scanning channel. For example, if channel 3 is specified and there are five channels in the scanning list, then the scanning sequence is: 3-1-3-2-3-3-3-4-3-5-3-1...	<ul style="list-style-type: none"> <li>None</li> <li>Float</li> <li>&lt;channel #&gt;</li> </ul>	None	Customer determined
Floating Priority	Instead of specifying a priority channel, this field allows you to use the last active RX, TX, or either RX or TX channels to be the priority channel. Priority Channel must be set to Float.	<ul style="list-style-type: none"> <li>Off</li> <li>RX</li> <li>TX</li> <li>RX + TX</li> </ul>	Off	Customer determined
Channel Marking	Allows a channel that has been determined to be active during the scanning process but that is busy to be marked. When marked, the scanning process does not wait the normal 250 msec when sampling that channel, but rather waits only the 30 msec required for carrier detection.	<ul style="list-style-type: none"> <li>Off</li> <li>Normal</li> <li>Priority</li> <li>Normal + Priority</li> </ul>	Off	Customer determined
Scan Delay	Specifies the amount of time after a non-priority channel becomes inactive before the scanning process continues.	0 to 10,000 msec	3000 msec	Customer determined

**Table 3-12** Scan List Configuration Data Fields (continued)

Data Field	Description	Range/ Selections	Default	Recommended Setting (if any)
Priority Scan Delay	Specifies the amount of time after a priority channel becomes inactive before the scanning process continues.	0 to 10,000 msec	3000 msec	Customer determined
Scan Sample Time	Specifies the amount of time the scanning process listens to each scanning channel for activity before it scans to the next channel.	20 to 10,000 msec	30 msec	Customer determined
Rx Qualify Time	Specifies the amount of time the scanning process listens for PL or DPL after first detecting a carrier on a particular channel.	210 to 4,000 msec	250 msec	Customer determined
Resume Scan Timer	Specifies the amount of time delay to begin the scanning process after the console has issued the resume command.	0 to 10,000 msec	2000 msec	Customer determined
Scan	Specifies whether the displayed channel is used for scanning operation.	<ul style="list-style-type: none"> <li>• Enabled</li> <li>• Disabled</li> </ul>	Disabled	Customer determined
TX Slave	Specifies whether the scan channel acts as a repeater channel, when the scanning process detects a carrier on a scanning channel the transmitter is keyed while locked on that channel.	<ul style="list-style-type: none"> <li>• Enabled</li> <li>• Disabled</li> </ul>	Disabled	Customer determined

# Programming the IntelliRepeater

The RSS program allows the user to set up the operating parameters for a station in an IntelliRepeater network. Figure 3-17 shows the IntelliRepeater screens provided in the navigation pane that are discussed in this section and Table 3-13 provides a description of each of the IntelliRepeater fields. The screens are applicable to both IntelliRepeater selections.



**Figure 3-17** IntelliRepeater Specific Configuration Screens

**Table 3-13** IntelliRepeater Screen Fields

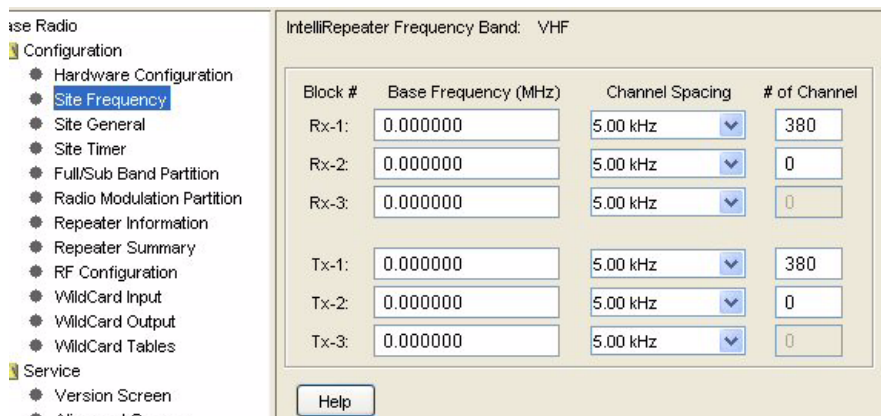
Field	Description
Serial Number	Serial number assigned to the radio by the factory
Station Name	User definable station name
Hardware Platform	Either QUANTAR or Quantro
System Type	<ul style="list-style-type: none"> <li>IntelliRepeater 3.0/3.5/4.1 supports either Analog or ASTRO CAI operation</li> <li>IntelliRepeater 2.0.3/2.7E supports either Analog or ASTRO VSELP operation</li> </ul>
Station Type	Select Analog, ASTRO CAI or ASTRO (VSELP)
RX Freq Band 1	Select the Rx Freq Range from the choice list
RX Freq Band 2	Not used for IR

**Table 3-13** IntelliRepeater Screen Fields (continued)

Field	Description
Tx Freq	Select the Tx Freq Range
IR Freq Band	Select the Trunking Band allocation type from choice list - Defined by system designer
PA Power Rating	Select the PA Type installed in the radio - use choice list
Power Supply	Select Power Supply installed in the radio
Battery Type	Select Battery Type connected to the radio
Wireline	Normally set to 4-wire. The 8-wire selection is used when the Enhanced Wild Card Option is purchased
Wild Card	Set by user to choice to DISABLED, BASIC or ENHANCED
Freq Ref	Select the frequency reference used for this radio - see choice list
Simulcast	Not applicable to IntelliRepeater
External Wattmeter	Enable if an External Wattmeter is connected to the radio

## Programming the Site Frequency Parameters

The Site Frequency screen is available only when VHF or UHF Rx and Tx frequency bands are selected in the Hardware Configuration screen. If the IntelliRepeater is operating in a VHF or UHF band then click **Site Frequency** in the navigation pane to access the Site Frequency screen (Figure 3-18). See Table 3-15 for the screen’s data fields.



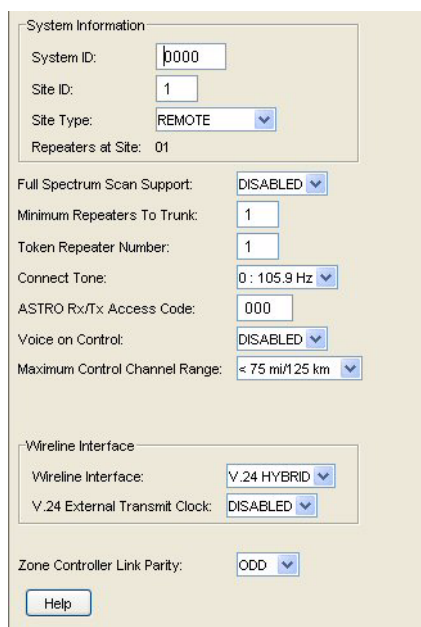
**Figure 3-18** Site Frequency Screen

**Table 3-14** Site Frequency Screen Data Fields

Data Field	Description	Range/ Selections	Default	Recommended Setting (if any)
Block #	VHF and UHF trunking spectrum is divided by FCC into three Rx frequency blocks and three Tx frequency blocks; each block is defined by a base frequency, channel spacing (kHz), and number of channels in the block.	Non-editable	Rx - 1 Rx - 2 Rx - 3  Tx - 1 Tx - 2 Tx - 3	non-editable
Base Frequency	User programming for starting frequency of each block of channels for receive or transmit.	Per each VHF or UHF FCC allocated channel starting frequency	0.00000	As determined by the Station Configuration
Channel Spacing	User Programmable for the FCC allocated channel spacing.	5, 6.25, 10, 12.5, 15, 18.75, 20, 25 (5kHz), 25 (6.25kHz), 30, 31.25, 35, 37.5, 40, 43.75, 50 kHz	5 kHz	As determined by the Station Configuration
# of Channels	VHF and UHF trunking spectrum is divided by FCC into 380 possible Rx channels and 380 possible Tx channels (per band).	0-380	0	As determined by the Station Configuration

## Programming the Site General Parameters

Click **Site General** in the navigation pane to access the Site General screen (Figure 3-19). See Table 3-15 for the screen’s data fields.



**Figure 3-19** Site General Screen

**Table 3-15** Site General Screen Data Fields

Data Field	Description	Range/ Selections	Default	Recommended Setting (if any)
System ID	A four digit field for entry of the system ID number.	0001-FFFF (hex)	0000	As determined by the system configuration, must be the same as TCMS system ID
Site ID	A two digit field for entry of the repeater site ID number used to inform zone controller of the site identity.	1 to 64	1	As determined by the system configuration
Site Type	This field allows two choices for the site type.	Remote Stand-alone	Remote	As determined by the system configuration
Minimum Repeaters to Trunk	This field specifies the minimum number of repeaters that must be operational before the site is allowed to trunk.	2 through maximum number of repeaters	2	Set to half the number of repeaters at site and rounded to next integer value. For example, for a nine repeater site, set this to "5", for an eight repeater site, set it to "4"
Token Repeater Number	In the event that a site with an even number of repeaters suffers a DLAN loss that divides the site in half, this field identifies the number of the repeaters (and therefore the side) that repeats. The other side enters failsoft mode. For example, a site with six repeaters (1-6) and a DLAN loss between 3 and 4 divides the site into two sides (1-3 and 4-6). If the Token Repeater Number is set to "5" then side 4-6 repeats and 1-3 enters failsoft mode.	1 through maximum number of repeaters	1	As determined by the system configuration
Connect Tone	This field allows eight choices: 0 through 7. These correspond to a connect tone frequency. 0 corresponds to 105.9 Hz, 1 corresponds to 76.6 Hz.	Use Help or refer to Appendix XXX.	105.9	As determined by the system configuration and must match the connect tone set in the subscribers
ASTRO Rx/Tx Access Code	This field defines receive/transmit ASTRO Network ID (hex).	000-FFF (hex)	293	Depends on system design
Voice on control	For single station trunked repeater application: Specifies whether station has capability to temporarily drop control channel operation and become a voice channel.	<ul style="list-style-type: none"> <li>Enabled</li> <li>Disabled</li> </ul>	Disabled	Customer determined
Maximum Control Channel Range	Effectively varies the time frame in which a subscriber for service (ISW) can be successfully received. Setting to a smaller range limits access by subscribers farther from site while also increasing chances of false service requests caused by random RF noise.	25 to 595 miles	<75 miles (125 km)	Customer determined
Failsoft Modulation Type	For IntelliRepeater 2.0.3/2.7E: Failsoft Modulation is on the Site General Screen because failsoft modulation is the same for all the channels. Specifies which voice mode is used while in failsoft mode.	<ul style="list-style-type: none"> <li>Analog</li> <li>ASTRO</li> </ul>	Analog	Depends on system configuration
Wireline Interface	The following apply to ASTRO CAI Capable IntelliRepeaters only: <ul style="list-style-type: none"> <li>V.24 Hybrid: Used for mixed mode, analog, and ASTRO systems, where the V.24 interface is used for ASTRO and control, and the Line 1/Line 2 wirelines are used for analog. Used only in trunked systems.</li> <li>V.24 Only: Used for ASTRO only systems where the external connection is either local or through microwave link.</li> </ul>	<ul style="list-style-type: none"> <li>V.24 Only</li> <li>V.24 Hybrid</li> </ul>	V.24 Hybrid	Customer determined

**Table 3-15** Site General Screen Data Fields (continued)

Data Field	Description	Range/Selections	Default	Recommended Setting (if any)
V.24 External Transmit Clock	Specifies whether external synchronization is required for transmit signal. Typically in installations where station and console are connected through a microwave link, RS232 Wireline Interface is used.	<ul style="list-style-type: none"> <li>Disabled</li> <li>Enabled</li> </ul>	Disabled	Customer determined
Zone Controller Link Parity	This defines the parity used to detect communication error with the zone controller.	<ul style="list-style-type: none"> <li>Odd</li> <li>Even</li> </ul>	Odd	Customer determined

## Programming the Site Timer Screen

Click **Site Timer** in the navigation pane to access the Site Timer screen (Figure 3-20). See Table 3-16 for the screen's data fields.

The screenshot shows a window titled "Timeout Timers" with the following settings:

- Link Recovery: 15 sec
- Carrier Malfunction: 50 sec
- Carrier: 500 msec
- Message Trunk: 1000 msec
- Fade: 1200 msec

A "Help" button is located at the bottom left of the window.

**Figure 3-20** Site Timer Screen**Table 3-16** Site Timer Screen Data Fields

Data Field	Description	Range/Selections	Default	Recommended Setting (if any)
Link Recovery	Sets the delay time before noting the loss or recovery of the data link between the station and zone controller and the time before exiting failsoft operation after a link recovery.	15-99 seconds	15	As determined by system configuration
Carrier Malfunction	Sets the delay time before taking a station out of service after a carrier malfunction is detected.	1-254 seconds (when set to 254, time delay is infinite)	50	As determined by system configuration
Carrier	Sets the time a station waits for radio handshakes to be established before leaving the assigned channel.	100-6300 msec	500	As determined by system configuration

**Table 3-16** Site Timer Screen Data Fields (continued)

Data Field	Description	Range/Selections	Default	Recommended Setting (if any)
Message Trunk	Sets the time the station waits before dekey after receiving the disconnect tone.	100-6300 msec	1000	As determined by system configuration
Fade	Sets the wait time before deassigning a channel after handshakes are lost but no disconnect tone is received.	100-6300 msec	1200	As determined by system configuration

## Programming Radio Modulation Partition Screens

Click **Radio Modulation Partition** in the navigation pane to access the Radio Modulation Partition screen. See Figure 3-21 for these screens. See Table 3-18 for the screen’s data fields.



**Figure 3-21** Radio Modulation Partition Screen

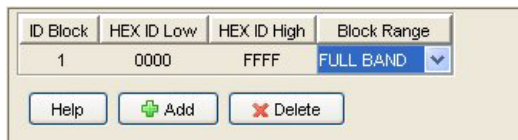
**Table 3-17** Radio Modulation Partition Screen Data Fields

Data Field	Description	Range/Selections	Default	Recommended Setting (if any)
ID Block	A sequential number that represents a given ID range			Depends on system design
Hex ID Low	This represents the low byte of the ID range			Depends on system design
Hex ID High	This represents the high byte of the ID range			Depends on system design
Modulation	Specifies which Modulation to use for the selected block	<ul style="list-style-type: none"> <li>• ASTRO</li> <li>• Analog</li> </ul>	Analog	Depends on system design



## Programming Full/Sub Band Partition Screens

To access the Full/Sub Band Partition screen, click **Full/Sub Band Partition** in the navigation pane. See Figure 3-22 for these screens. See Table 3-18 for the screen’s data fields.



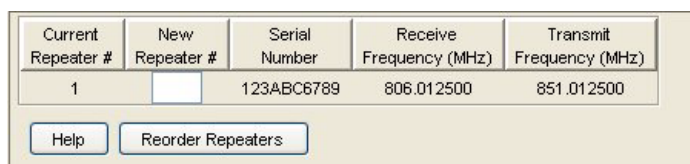
**Figure 3-22** Full/Sub Band Partition and Radio Modulation Partition Screen

**Table 3-18** Full/Sub Band Partition Screen Data Fields

Data Field	Description	Range/Selections	Default	Recommended Setting (if any)
ID Block	A sequential number that represents a given ID range			Depends on system design
Hex ID Low	This represents the low byte of the ID range			Depends on system design
Hex ID High	This represents the high byte of the ID range			Depends on system design
Block Range		<ul style="list-style-type: none"> <li>• Full Band</li> <li>• Sub Band</li> </ul>	Full Band	Depends on system design

## Programming Repeater Summary Screen

This screen allows you to reorder the IntelliRepeaters at the site. To access the Repeater Summary screen, click **Repeater Summary** in the navigation pane. See Figure 3-23.



**Figure 3-23** Repeater Summary Screen

## Programming the Repeater Information Screen

Click **Repeater Information** in the navigation pane to access the Repeater Information screen (see Figure 3-20). See Table 3-16 for the screen's data fields.

Repeater Number: 1 Repeater# 1 of 1

Basic | Advanced

Serial Number: 123ABC6789

Base Repeater Rx Frequency: 0.000000 MHz Rx Channel#: 0

Base Repeater Tx Frequency: 0.000000 MHz Tx Channel#: 380

Base Station Identification:

Control Channel Capability: DISABLED

Preferred Control Channel Rank: 0

Dispatch Capability: ASTRO

Failsort Capability: DISABLED Failsort Modulation: ASTRO

BSI Capability: DISABLED

DFB Capability: DISABLED

Secure Capability: DISABLED

Protect Capability: DISABLED

SubBand Capability: DISABLED

Help Add Repeater Previous Repeater Next Repeater Delete Repeater

**Figure 3-24** Repeater Information Screen - Basic Tab

Repeater Number: 1 Repeater# 1 of 1

Basic | Advanced

Modulation Type: ANALOG

Tx Rated Deviation: 5.000 kHz

Receive Channel BW: WIDE 25-30 kHz Channel Spacing

Tx Power Out: 20 Watts

Tx Power Out Battery Backup: 10 Watts

Rcv Signal Inversion: DISABLED

Analog Repeater Boost: ENABLED

Comander: DISABLED

Noise Canceller: DISABLED

Help Add Repeater Previous Repeater Next Repeater Delete Repeater

**Figure 3-25** Repeater Information Screen - Advanced Tab

**Table 3-19** Repeater Information Screen Data Fields

Data Field	Description	Range/Selections	Default	Recommended Setting (if any)
<b>Basic Tab:</b>				
Repeater Number	Identifies the repeater number selected through this screen.	1-28 digits	1	As determined by the system configuration
Serial Number	This field shows the serial number of the station to which this screen applies.	1 to 10 digits	123ABC6789	Depends on the system design
Base Repeater Rx Frequency	Receive frequency in KHz for the selected repeater.	Follows input of Base Repeater Tx Frequency	45 MHz less than Tx frequency	Non-editable
Base Repeater Tx Frequency	Transmit frequency in MHz for the selected repeater.	Depends on band	851.0125 MHz	Depends on the system design
Base Station Identification	The Morse Code ID for the station. An entry must be provided if BSI Capability is set to Enabled.	Up to eight alpha-numeric characters in length	None	Assigned by FCC. Refer to system design document
Control Channel Capability	Indicates whether the station is capable of operating as a control channel station.	<ul style="list-style-type: none"> <li>• Enabled</li> <li>• Disabled</li> </ul>	Disabled	Enabled if station is to be used as a control channel, if not it is disabled
Preferred Control Channel Rank	Assigns preference level for channel's use as the control channel.	0-4 (0 = disabled)	4	As determined by the system design
Dispatch Capability	Indicates whether the station can make dispatch calls.	<ul style="list-style-type: none"> <li>Disabled</li> <li>Analog</li> <li>ASTRO</li> <li>Analog/ASTRO</li> </ul>	Analog	As determined by the system design
Failsoft Capability	Indicates whether the repeater can operate in the failsoft mode.	<ul style="list-style-type: none"> <li>• Enabled</li> <li>• Disabled</li> </ul>	Disabled	As determined by the system design
BSI Capability	Indicates whether the repeater can operate in the BSI operating mode. If set to Enabled, an entry must be provided for Base Station Identification.	<ul style="list-style-type: none"> <li>• Enabled</li> <li>• Disabled</li> </ul>	Disabled	As determined by the system design
DFB Capability	Indicates whether repeater is capable of dynamic frequency blocking.	<ul style="list-style-type: none"> <li>• Enabled</li> <li>• Disabled</li> </ul>	Disabled	As determined by the system design
Secure Capability	Indicates whether the repeater is capable of operating as a secure station.	<ul style="list-style-type: none"> <li>• 12 Kb ASTRO Secure</li> <li>• Disabled</li> </ul>	Disabled	As determined by the system design
Protect Capability	Prevents the station from being assigned as a control channel or to a dispatch call unless it is the only repeater available.	<ul style="list-style-type: none"> <li>• Enabled</li> <li>• Disabled</li> </ul>	Disabled	As determined by the system design
Subband Capability	Indicates whether the repeater can operate at sub-band frequencies. Allows system to be optimized for more efficient call steering.	<ul style="list-style-type: none"> <li>• Enabled</li> <li>• Disabled</li> </ul>	Disabled	As determined by the system design
Failsoft Modulation Type	For IntelliRepeater 3.0/3.5/4.1: Failsoft Modulation is on the Site Repeater Screen because failsoft modulation can be set individually for each channel. Specifies which voice mode is used while in failsoft mode.	<ul style="list-style-type: none"> <li>• Analog</li> <li>• ASTRO</li> </ul>	Analog	Depends on the system configuration

**Table 3-19** Repeater Information Screen Data Fields (continued)

Data Field	Description	Range/Selections	Default	Recommended Setting (if any)
<b>Advanced Tab:</b>				
Modulation Type	Specifies the type of modulation for current channel. The selections provided depend on the Station Type selected in the Hardware Configuration screen.	<ul style="list-style-type: none"> <li>Analog</li> <li>ASTRO</li> <li>Analog/ASTRO</li> <li>ASTRO RX WIDE DEV</li> <li>Secure XL</li> <li>Analog/Sec XL</li> <li>Secure CFB</li> <li>Analog/Sec CFB</li> <li>Analog CAI</li> <li>Analog/ASTRO CAI</li> <li>CAI Rx Wide Dev</li> </ul>	<ul style="list-style-type: none"> <li>Analog if Station Type is Analog</li> <li>Analog/ASTRO if Station Type is ASTRO Capable</li> </ul>	As determined by the system design
Tx Rated Deviation	Specifies the maximum frequency deviation allowed in channel.	<ul style="list-style-type: none"> <li>5.00 kHz</li> <li>4 kHz</li> <li>2.5 kHz</li> </ul>	5.00 kHz	Determined by FCC per channel type. Depends on the system design
Receive Channel BW	Specifies the frequency spacing (in kHz) between channels.	<ul style="list-style-type: none"> <li>Wide (25-30 kHz)</li> <li>NPSAC (25 kHz)</li> <li>Narrow (12.5-15 kHz)</li> <li>Narrow (12.5 kHz)</li> </ul>	Wide	Determined by FCC per channel type. Depends on the system design
Tx Power Out	Specifies the output power from the station power amplifier module. This field is limited to a pre-determined output power level if the station is equipped with the Limited Output Power option.	<ul style="list-style-type: none"> <li>Quantro: 50% to 110%</li> <li>QUANTAR: 25% to 110%</li> </ul> of the station's power rating	The full power selected in PA Power Rating	Refer to system design document for FCC licensed power rating
Tx Power Out Battery Backup	Specifies the output power from the station power amplifier module when in battery backup mode.	<ul style="list-style-type: none"> <li>Quantro: 50% to 110%</li> <li>QUANTAR: 25% to 110%</li> </ul> of the station's power rating	50% of value selected in PA Power Rating	Customer defined. Set to lower value to extend station operation in battery backup mode
Rcv Signal Inversion	Allows polarity of receive signal to be inverted.	<ul style="list-style-type: none"> <li>Enabled</li> <li>Disabled</li> </ul>	Disabled	Customer defined
Analog Repeater Boost	Specifies whether the received signal is boosted prior to transmission by repeater. Boost = 150% (3 dB). Example: 2 kHz deviation receive signal is repeated at 3 kHz deviation.	<ul style="list-style-type: none"> <li>Enabled</li> <li>Disabled</li> </ul>	Disabled	Customer defined
Compander	Determines whether the companding (compression and expansion) is employed for transmit/receive signals.	<ul style="list-style-type: none"> <li>Enabled</li> <li>Disabled</li> </ul>	Disabled	Applies to 900 MHz only. Must be enabled for 900 MHz stations
Noise Canceller	Determines whether the receiver noise cancellation is employed.	<ul style="list-style-type: none"> <li>Enabled</li> <li>Disabled</li> </ul>	Disabled	Must be enabled for 900 MHz stations. Customer determined

## Programming RF Configuration

Click **RF Configuration** in the navigation pane to access the RF Configuration screen. See Figure 3-26 and Figure 3-27 for views of the RF Configuration screens. See Table 3-20 for the screen's data fields.

Repeater Operation: BASE

Max Deviation: 92 %

Low Speed/PL Deviation: 17.0 %

Antenna  
Antenna Relay: DISABLED

Call Sign Interval: 60 min

Startup On Last Active Channel: DISABLED

Startup Channel: 1

ASTRO RDLAP  
Repeat: DISABLED  
Wireline Drop Out Delay: 0 sec

ASTRO Tx Filter: WIDE PULSE

ANALOG Simulcast Reverse Burst: INTERNAL

Conventional - Analog

Repeater Operation: BASE

Max Deviation: 92 %

Low Speed/PL Deviation: 17.0 %

Antenna  
Antenna Relay: DISABLED

Call Sign Interval: 60 min

Startup On Last Active Channel: DISABLED

Startup Channel: 1

ASTRO Fade Tolerance: 3 FRAMES

ASTRO RDLAP  
Repeat: DISABLED  
Wireline Drop Out Delay: 0 sec

ASTRO Tx Filter: WIDE PULSE

ANALOG Simulcast Reverse Burst: INTERNAL

Conventional - ASTRO

Figure 3-26 RF Configuration Screen - Conventional Stations

Max Deviation: 92 %

Low Speed Deviation: 17.0 %

ASTRO Fade Tolerance: 3 FRAMES

Help

IntelliRepeater - Analog

Max Deviation: 92 %

Antenna Relay Delay: 30 msec

Low Speed Deviation: 17.0 %

Rx Carrier Detect Fade Timer: 80 msec

ASTRO Fade Tolerance: 3 FRAMES

Help

IntelliRepeater - ASTRO

Repeater Operation: BASE

Max Deviation: 92 %

Low Speed/PL Deviation: 17.0 %

Antenna  
Antenna Relay: DISABLED

Call Sign Interval: 60 min

Startup On Last Active Channel: DISABLED

Startup Channel: 1

ASTRO RDLAP  
Repeat: DISABLED  
Wireline Drop Out Delay: 0 sec

ASTRO Tx Filter: WIDE PULSE

6809 Trunking - Analog

Repeater Operation: BASE

Max Deviation: 92 %

Low Speed/PL Deviation: 17.0 %

Antenna  
Antenna Relay: DISABLED

Call Sign Interval: 60 min

Startup On Last Active Channel: DISABLED

Startup Channel: 1

ASTRO Fade Tolerance: 3 FRAMES

ASTRO RDLAP  
Repeat: DISABLED  
Wireline Drop Out Delay: 0 sec

ASTRO Tx Filter: WIDE PULSE

6809 Trunking - ASTRO

Figure 3-27 RF Configuration Screen - IntelliRepeater and 6809 Trunking Stations

**Table 3-20** RF Configuration Data Fields

Data Field	Description	Range/ Selections	Default	Recommended Setting (if any)
Repeater Operation	This specifies whether the station is used as a base station or repeater.	<ul style="list-style-type: none"> <li>• Base</li> <li>• Repeater</li> </ul>	Base	Depends on system configuration
Max Deviation	Limits the station transmit deviation to a percentage of maximum as set on the Channel Information screen.	0-100%	92%	92% recommended
Low Speed/PL Deviation	Specifies deviation for low speed TDATA for 6809 trunking applications.	0-25%	<ul style="list-style-type: none"> <li>• 17% for 25 kHz</li> <li>• 18% for 12.5 kHz</li> </ul>	Use value shown for the bandwidth in use
Antenna Relay	This specifies whether the antenna relay is in use.	<ul style="list-style-type: none"> <li>• Enabled</li> <li>• Disabled</li> </ul>	Disabled	Depends on system configuration
Call Sign Interval	Specifies time intervals at which FCC assigned station call sign is broadcast.	1-60 minutes	60 min.	Set time less than or equal to the time specified by the FCC
Startup on Last Active Channel	Specifies that the last active channel is used as the current startup channel if enabled. Otherwise, the startup channel is specified in the Startup Channel field.	<ul style="list-style-type: none"> <li>• Enabled</li> <li>• Disabled</li> </ul>	Disabled	Depends on system configuration
Startup Channel	Specifies the channel selected as the Startup Channel after reset.	1 to 16	1	Depends on system configuration
ASTRO Fade Tolerance	Specifies the number of missed frames before ASTRO message is considered.	1-3 frames	3 frames	Customer defined
ASTRO Tx Filter	Selects the ASTRO transmit modulation filter to be used.	<ul style="list-style-type: none"> <li>• Wide Pulse</li> <li>• Narrow Pulse</li> </ul>	Wide Pulse	System dependent
Analog Simulcast Reverse Burst	Specifies the appropriate simulcast reverse burst.	<ul style="list-style-type: none"> <li>• Internal</li> <li>• External</li> </ul>	Internal	System dependent (for conventional simulcast only)
Repeat	Specifies whether ASTRO RDLAP data is repeated.	<ul style="list-style-type: none"> <li>• Enabled</li> <li>• Disabled</li> </ul>	Disabled	System dependent
Wireline Drop Out Delay	Specifies the amount of hang time added to the end of an RDLAP and ASTRO CAI WL transmission.	0-999 seconds	0 sec	System dependent

## Programming the Codeplug Data into a Conventional or 6809 Station or ASTRO-TAC Comparator

After saving the codeplug data to an archive file on the PC hard disk, you must program the codeplug data into a conventional or 6809 station's codeplug.



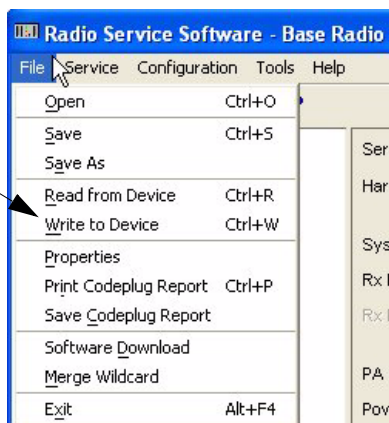
**NOTE**

When programming the codeplug, you may be asked whether you want to condition the codeplug. Follow the instructions in the message window to perform this task. Conditioning is required only once.

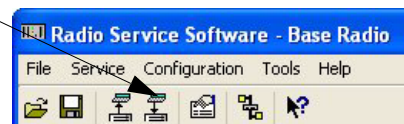
With the PC connected and the RSS program running, perform the following to program data into the station codeplug:

1. From the **File** menu, select **Write to Device**, or **Write to Device** icon on the toolbar.

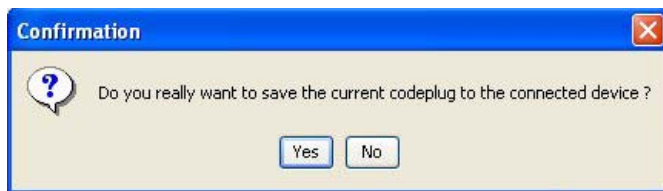
**File/Write to Device Menu Item**



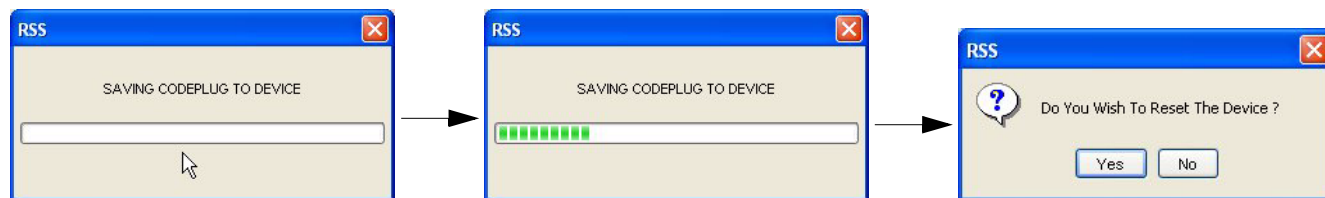
**Save file icon**



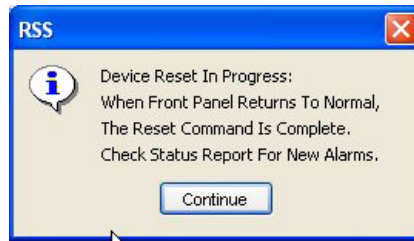
A confirmation window appears.



2. Click **Yes**. The progress of the write operation appears. When the operation is complete, an RSS message window asks whether you would like to reset the device.



3. Click **Yes** to reset the device to activate the codeplug you just wrote to the device. A message window appears stating that a reset is in progress.



4. Click **Continue**. On reset the following window is opened.



5. Click **Continue**. The main RSS window appears.

## Programming the Codeplug Data into an IntelliRepeater Station Installed in a SmartZone 2.0.3 or 2.7E System

After saving the codeplug data to an archive file on the PC hard disk, you must program the codeplug data into a conventional or 6809 station's codeplug.



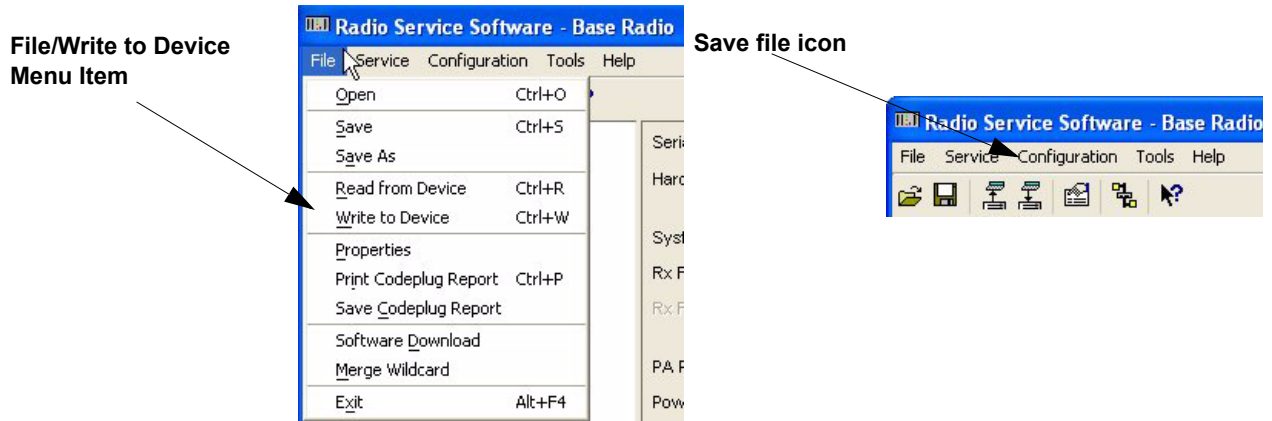
### NOTE

When programming the codeplug, you may be asked whether you want to condition the codeplug. Follow the instructions in the message window to perform this task. Conditioning is required only once.

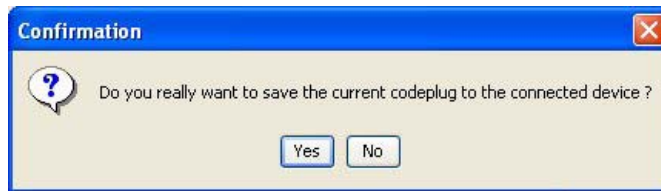
With the PC connected and the RSS program running, perform the following to program data into the station codeplug:

1. From the **File** menu, select **Write to Device**, or click **Write to Device** icon on the toolbar.





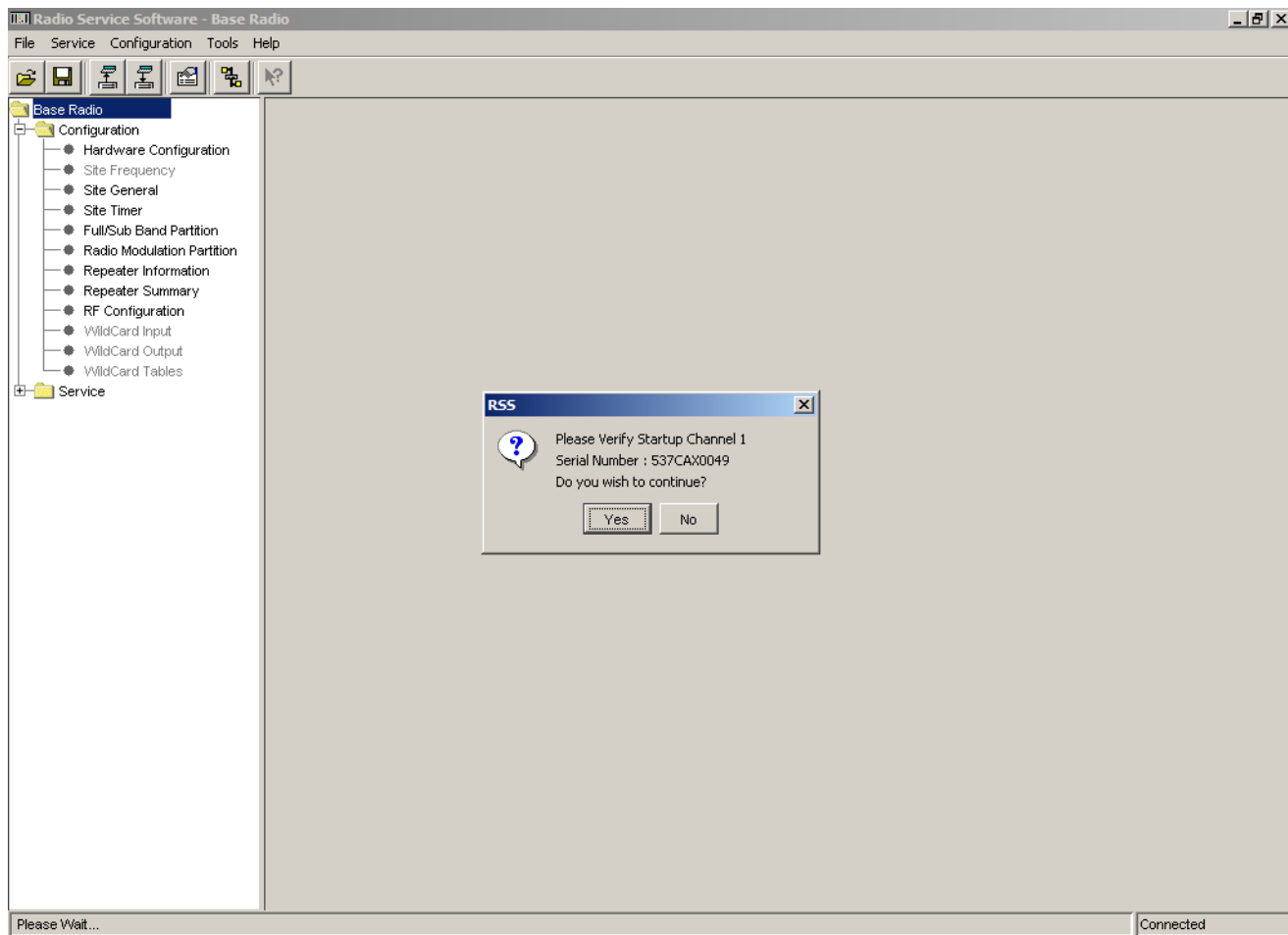
A confirmation window appears.



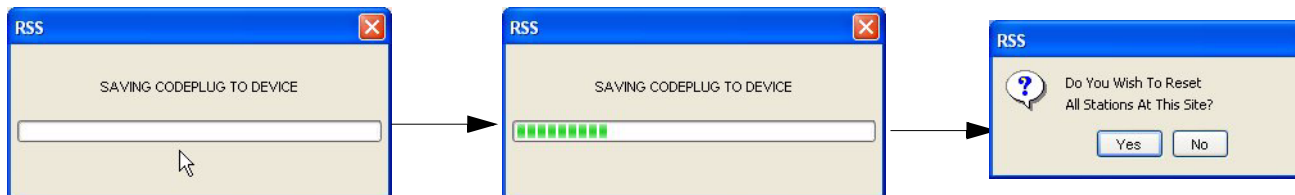
2. Click **Yes**. After a few seconds, the following **Please Enter the Start Up Channel** window appears.



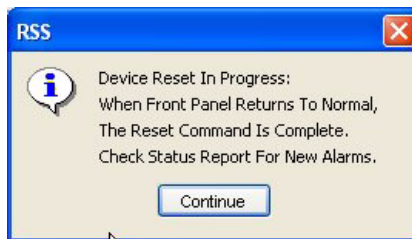
3. Verify that the displayed channel is the start up channel. Change if required. Then click **Next >>**. A message window appears asking for verification of the Startup Channel and the serial number.



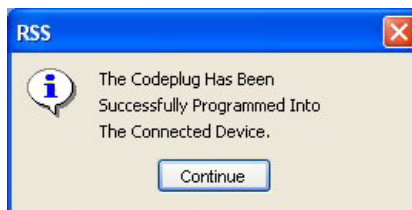
4. Click **Yes** to start the codeplug write operation. The progress of the write operation appears. When the operation is complete, an RSS message window asks whether you would like to reset the device.



5. Click **Yes** to reset all connected IntelliRepeaters to activate the codeplug. A message window appears stating that a reset is in progress.



6. Click **Continue**. On reset, the following window appears.



7. Click **Continue**. The display returns to the main RSS window.

## Programming the Codeplug Data into an IntelliRepeater Station Installed in a SmartZone 3.0, 3.5, or 4.1 System

After saving the codeplug data to an archive file on the PC hard disk, you must program the codeplug data into a conventional or 6809 station's codeplug.

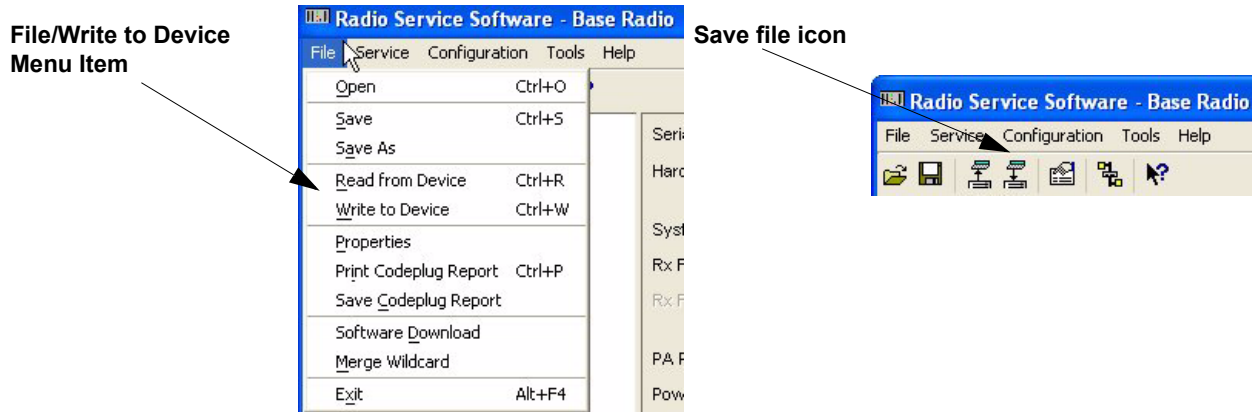


### NOTE

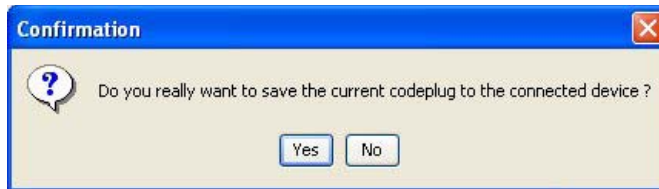
When programming the codeplug, you may be asked whether you want to condition the codeplug. Follow the instructions in the message window to perform this task. Conditioning is required only once.

With the PC connected and the RSS program running, perform the following to program data into the station codeplug:

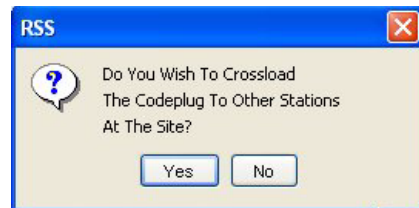
1. From the **File** menu, select **Write to Device**, or click **Write to Device** icon on the toolbar.



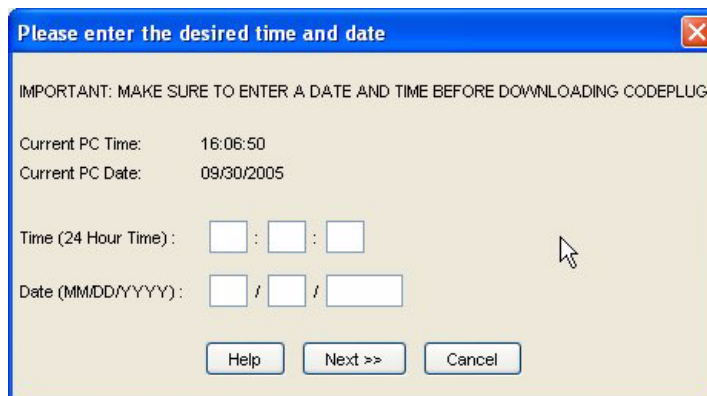
A confirmation window appears.



2. Click **Yes**. After a few seconds the following crossload message window appears.



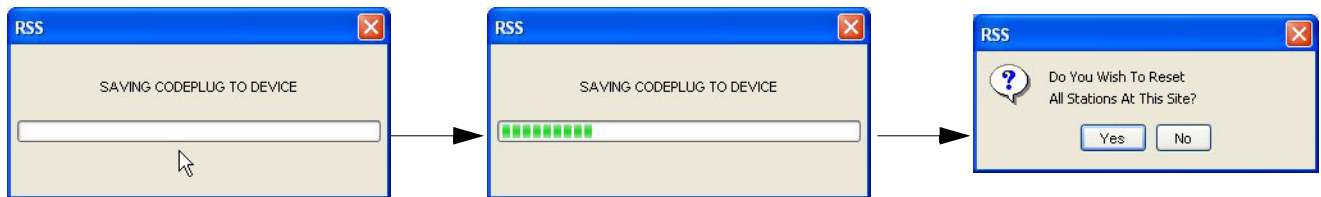
3. Click **Yes** to write the codeplug to the connected IntelliRepeater station and then have that station load on each IntelliRepeater connected to it with the codeplug. The following **Please enter the desired time and date** window appears.



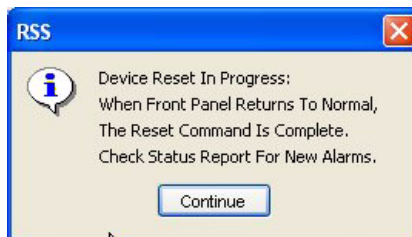
4. Enter the current date and time.
5. When complete, click **Next**. The following **Please Enter the Start Up Channel** window appears.



6. Verify that the displayed channel is the start up channel. Change if required. Then click **Next>>**.
7. Click **Yes** to start the codeplug write operation. The progress of the write operation appears. When the operation is complete, an RSS message window asks whether you would like to reset the device.



8. Click **Yes** to reset all connected IntelliRepeaters to activate the codeplug. A message window is opened stating that a reset is in progress.



9. Click **Continue**. On reset, the following window is opened.



10. Click **Continue**. The display returns to the main RSS window.

## Performing Station Alignment

Some of the station tuning, alignment, and adjustment tasks have been performed in the factory prior to shipment. These procedures do not need to be performed at the time of installation and are generally required only after maintenance of certain modules. These procedures are listed below with their location in this manual.

- “Aligning Power Output Procedure” on page 6-4
- “Aligning Power Output Procedure for a Quantro 350W VHF Station” on page 6-7
- “Aligning Tx Deviation Gain Adjust Procedure, 350W VHF Stations” on page 6-11
- “Aligning Reference Modulation Compensation Procedure” on page 6-14

Certain site-specific alignment tasks must be performed during optimization at the time they are installed and prior to being placed into service. The tasks required are shown below:

- “RX and TX Wireline Alignment” on page 3-55
- “Aligning Radio Signal Strength Indicator (RSSI)” on page 3-68
- “Aligning Squelch Adjust Procedure” on page 3-71
- “Equalizing Batteries” on page 3-73
- “Calibrating Reference Oscillator Procedure” on page 3-75
- “Setting ASTRO Tx Align and Test Procedure” on page 3-82
- “Generating ASTRO Test Patterns” on page 3-85
- “TDATA Calibration (6809 Trunking Station Only)” on page 3-88
- “ASTRO Bit Error Rate Reports” on page 3-90



### IMPORTANT

Before performing any of the station alignment procedures, you must dekey the station transmitter. In addition, when you enter the Alignment Screen, the following prompt is displayed, "The station is Automatically put into Access Disable mode. A station reset is required to return the station to Access Enable. Do you want to continue?" Click **Yes** to continue. When the alignment procedures are completed, deactivate Access Disable and restore the station to normal operation by performing a station reset.

**IMPORTANT**

When entering data in any of the alignment screen fields, you must click **Save** to save the value to the station. If you enter a parameter value and exit the alignment screen without saving the value, the station continues to operate using the previous value.

**NOTE**

If you experiment with a parameter value without intending to permanently change the value stored in the station, do not click **Save** and reset the station to restore the original parameter value(s).

## Required Test Equipment

The following test equipment is required for optimization:

- Motorola R2001 communications analyzer (or equivalent)
- Motorola R2600 communications analyzer (or equivalent)
- Motorola R2650 ASTRO communications analyzer (or equivalent)

## RX and TX Wireline Alignment

The station may be equipped with a 4-wire or 8-wire wireline interface board. Depending on the system application and the specific wireline board, the following wireline circuit configurations are supported:

- 2-wire half duplex
- 4-wire half duplex
- 4-wire full duplex
- 6-wire full duplex
- 8-wire full duplex

Alignment of the receive (Rx) and transmit (Tx) circuits is required depending on the system application, wireline circuit configuration, and whether equalization is required or desired. Use Table 3-21, Table 3-22, and Table 3-23 to determine the Rx and Tx lines that require alignment and/or equalization and the specific alignment procedure(s) to perform. The following examples show you how to use the tables:

- **Example 1:** For a station programmed for 4-wire operation, ALC disabled, and not in a voting system, Table 3-21 shows that Line 1 requires alignment procedure E and Line 2 requires alignment procedure A. Equalization is optional because the station is not in a voting system.

- **Example 2:** For a station programmed for 4-wire operation, ALC enabled, and in a voting system, Table 3-21 shows that Line 1 requires no alignment and that Line 2 requires alignment procedure A. The Equalization Matrix shows that Line 2 also requires alignment procedures B, D, and C (if needed).
- **Example 3:** For a station programmed for 8-wire operation and ALC enabled, Table 3-21 shows that Line 1 requires alignment procedure E, Line 2 requires alignment procedure A, Line 3 requires no alignment, and Line 4 requires alignment procedure A.

**Table 3-21** RX/TX Wireline Alignment Matrix

Wireline Circuit Configuration <sup>1</sup>	Automatic Level Control (ALC)	Alignment Procedure Required			
		L1 (TX)	L2 (RX)	L3 (TX)	L4 (RX)
2-wire	Off	Note 2	A and E	N/A	N/A
	On		A and E		
4-wire	Off	E	A	N/A	N/A
	On	None	A		
6-wire	Off	E	A	E	N/A
	On	E	A	None	
8-wire	Off	E	A	E	A
	On	E	A	None	A

## Notes:

1. The 2, 4, 6, and 8-wire configurations provide direct connection to a console. Stations in voting systems must be configured for 4-wire configuration.
2. For 2-wire configurations, Rx and Tx alignments are both performed on Line 2.

**Table 3-22** RX/TX Wireline Equalization Matrix

Equalization Required for Voice or Status Tone (station in voting system)	Alignment Procedure Required			
	L1 (TX)	L2 (TR)	L3 (TX)	L4 (RX)
Voice	N/A	B C (if required)	N/A	None
Status Tone	N/A	D	N/A	None

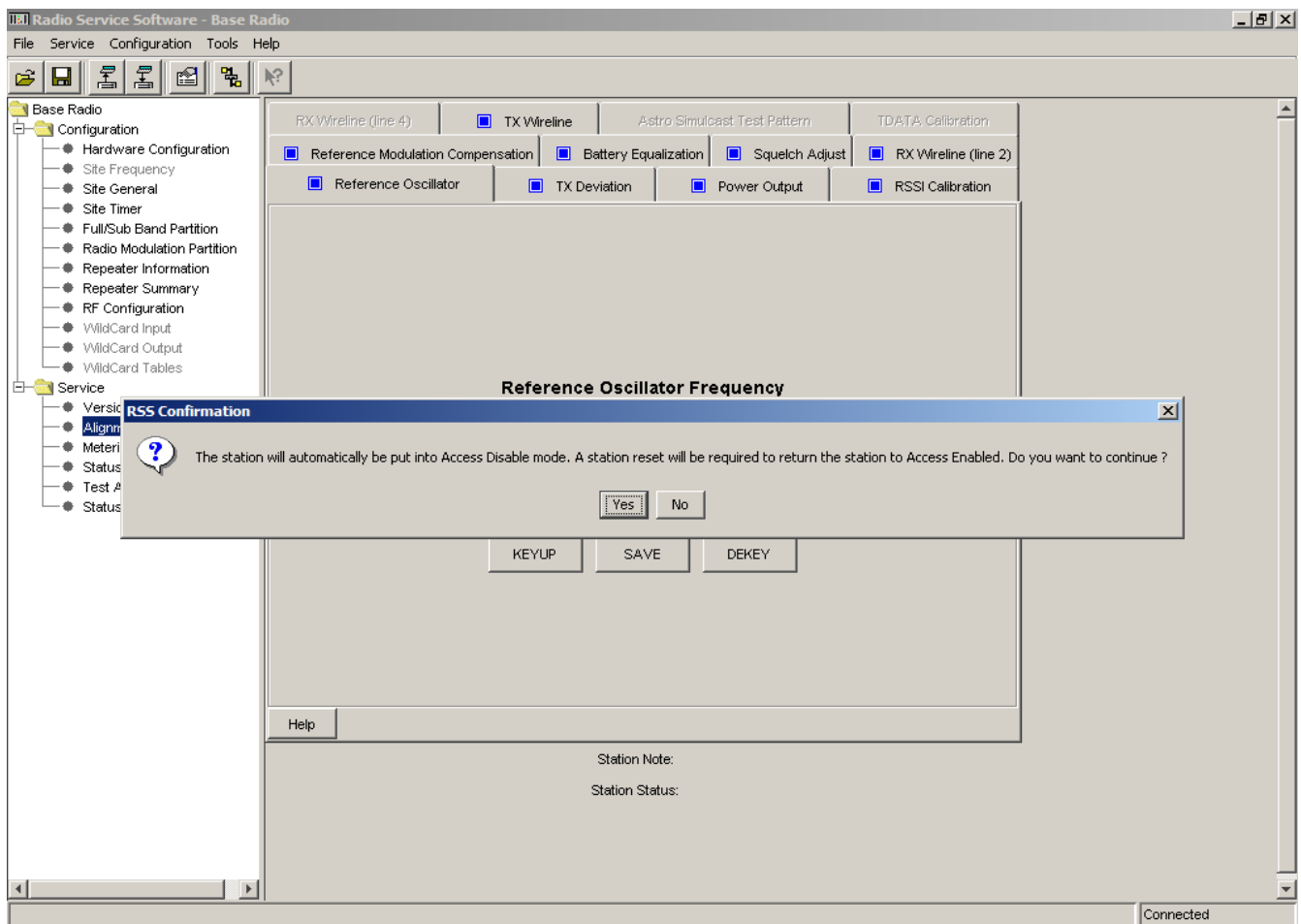
**Table 3-23** RX Wireline ASTRO Link Management Tone Alignment Matrix

Alignment Required for ASTRO Station with Hybrid Link	Alignment Procedure Required			
	L1 (TX)	L2 (TR)	L3 (TX)	L4 (RX)
Link Management Tone	N/A	F	N/A	N/A



## Procedure A: Rx Wireline Alignment Procedure

1. Disconnect the station's receive antenna cable.
2. Launch the RSS program as outlined in "Launching the RSS Program" on page 2-12.
3. Read the station's codeplug as outlined in "Reading the Device Codeplug" on page 2-14. You are now connected to the station.
4. Click the + sign next to Service to expand the Service menu.
5. Click **Alignment Screen** in the navigation pane.



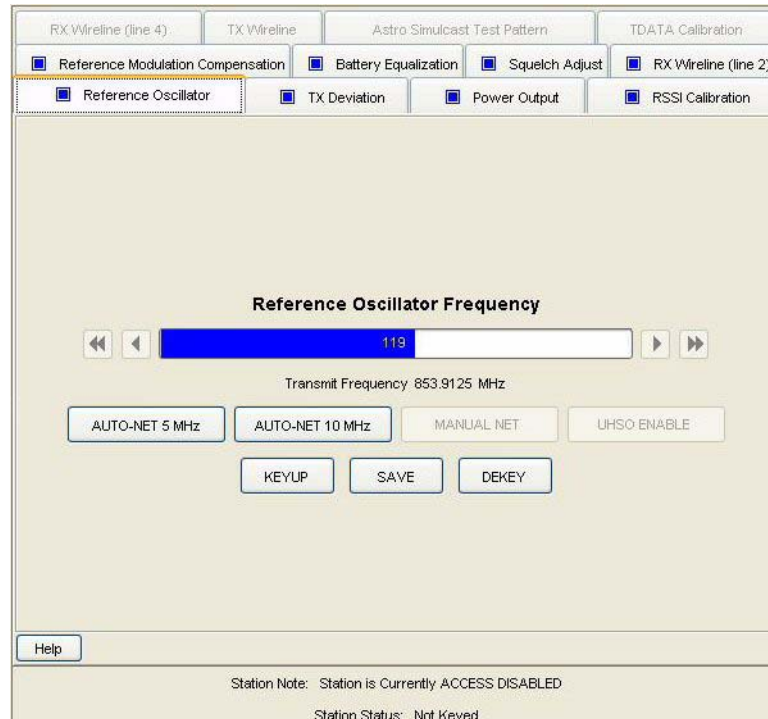
6. Click **Yes** to continue.



### NOTE

When the alignment procedures are completed, deactivate Access Disable and restore the station to normal operation by performing a station reset.

The Reference Oscillator Alignment screen appears.



7. Click **RX Wireline (Line 2)** tab, a confirmation window appears.
8. Click **Yes**. The **Rx Wireline (Line 2)** screen appears.



9. In the **Rx Wireline Level (1 kHz) field**: Enter the wireline level desired for a received RF signal at 60% of the rated system deviation. Typically, the wireline level is defined in your system's design document. The allowable range is -20 to 0 dBm.
10. Click **Save**. The station automatically adjusts for the Rx wireline level you entered and stores the value in station memory.

**NOTE**

Pressing the **Enter** key does not save the entered value to the station.

11. Repeat this procedure for Rx Wireline (Line 4) if applicable.

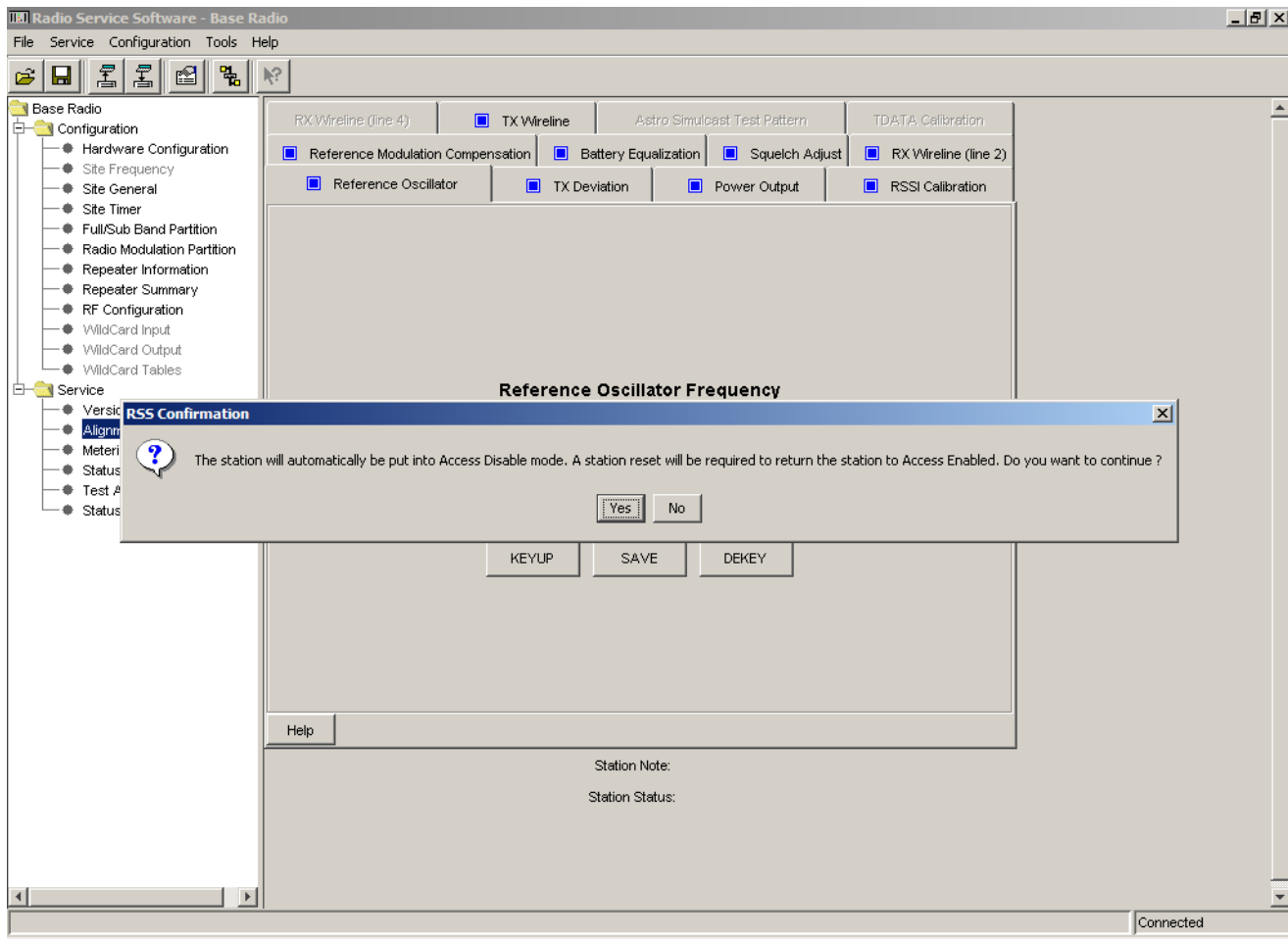
## Procedure B: Rx Wireline Equalization Alignment Procedure

This procedure applies only for a station that is part of a receiver voting system, such as Spectra-TAC, Digi-TAC, or ASTRO-TAC. To adjust for Rx Wireline equalization, perform the following procedure.

**NOTE**

If the comparator and station are not collocated, then two technicians are required to perform this procedure, one at the comparator and one at the station.

1. At the comparator, connect a high-impedance AC voltmeter across the phone line input corresponding to the station/receiver being aligned.
2. Launch the RSS program as outlined in “Launching the RSS Program” on page 2-12.
3. Read the station's codeplug as outlined in “Reading the Device Codeplug” on page 2-14. You are now connected to the station.
4. Click the + sign next to Service to expand the Service menu.
5. Click **Alignment Screen** in the navigation pane.



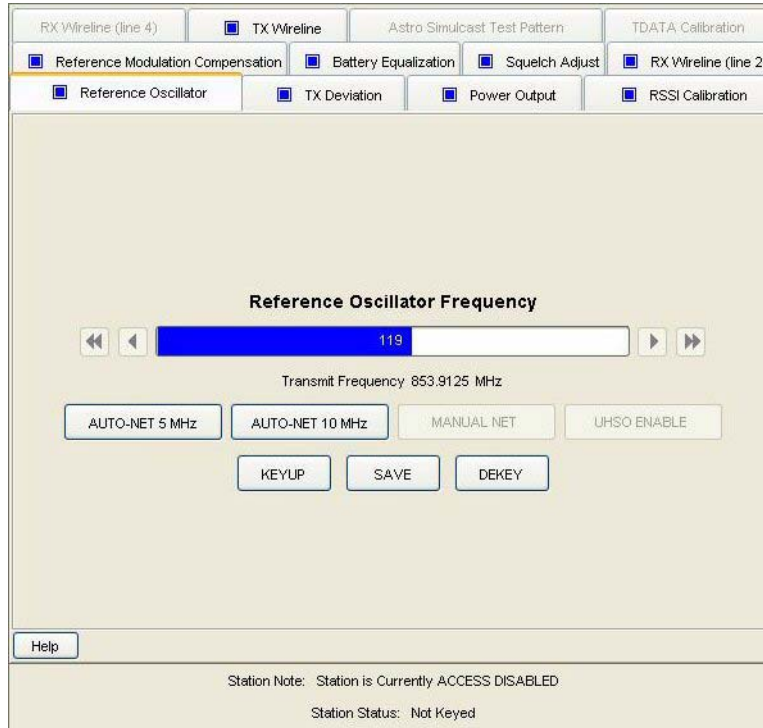
6. Click **Yes** to continue.



### NOTE

When the alignment procedures are completed, deactivate Access Disable and restore the station to normal operation by performing a station reset.

The Reference Oscillator Alignment screen appears.



7. Click the **RX Wireline (Line 2)** tab. The **Rx Wireline (Line 2)** screen appears.



- Click **Tone On**, to cause the station/receiver to generate a 1 kHz test tone (at the level specified in “Procedure A: Rx Wireline Alignment Procedure” on page 3-57). Measure (in dBm) and record the value as indicated on the AC voltmeter connected to the comparator.

		Current	Stored
<input type="button" value="Tone On"/>	<b>RX Wireline Level (1 KHz)</b>	-6 dBm	-6 dBm
<input type="button" value="Tone Off"/>	<b>Audio Level</b>	-1.6 dBm	

Press to turn on the 1 KHz tone

- Click **Tone Off** near the bottom of the pane.

### Local Oscillator Boost Equalization (Optional)

- Click **Tone On** for Local Oscillator (LO) Boost Adjust Level @ 400 Hz in the Rx Wireline Equalization section, to cause the station/receiver to generate a 400 Hz alignment tone. Measure (in dBm) and record the value.

		Current	Stored
<input type="button" value="Tone On"/>	<b>LO Boost Adjust Level @400 Hz</b>	0.0 dB	0.0 dB
<input type="button" value="Tone On"/>	<b>LO Boost Adjust Level @ 2500 Hz</b>	0.0 dB	0.0 dB
<input type="button" value="Set Freq"/>	<b>Hi Boost Frequency</b>	2500 Hz	2500 Hz

Press to turn on the LO Boost tone @ 2500 Hz

- Click **Tone Off** near the bottom of the pane.
- Subtract the absolute value measured in step 8 from the absolute value measured in step 10 and enter the result in LO Boost Adjust Level @ 400 Hz Current field.

#### Example:

-22.8 dBm measured in step 8.

-25.4 dBm measured in step 10.

$25.4 - 22.8 = 2.6$  (if the result is negative, use 0)

Enter 2.6 in LO Boost Adjust Level @ 400 Hz Current field.

### Hi Boost Level Equalization



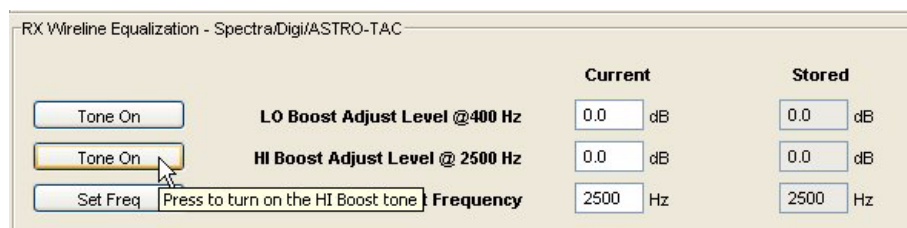
#### NOTE

In most cases, the default 2500 Hz Hi Boost Frequency is acceptable. If the telephone lines exhibit a notch or peak at 2500 Hz, you may need to change the boost frequency by entering another frequency, such as between 2200 Hz and 2800 Hz, in the Hi Boost Frequency field and then click the **Set Freq.**

- Click **Tone On**, to cause the station/receiver to generate a 1 kHz test tone (at the level specified in “Procedure A: Rx Wireline Alignment Procedure” on page 3-57). Measure (in dBm) and record the new value as indicated on the AC voltmeter connected to the comparator.



- Click **Tone On** for HI Boost Adjust Level @ 2500 Hz in the Rx Wireline Equalization section, to cause the station/receiver to generate a 2500 Hz alignment tone. Measure (in dBm) and record the value.



- Click **Tone Off** near the bottom of the pane.
- Subtract the absolute value measured in step 13 from the absolute value measured in step 14 and enter the result in LO Boost Adjust Level @ 400 Hz Current field.

**Example:**

-22.8 dBm measured in step 13.

-27.5 dBm measured in step 14.

$27.5 - 22.8 = 4.7$  (if the result is negative, use 0)

Enter 4.7 in HI Boost Adjust Level @ 2500 Hz Current field.

- After all equalization settings have been entered, click **Save** at the bottom of the pane to save the values to non-volatile memory in the station.

**Procedure C: Status Tone Level Alignment Procedure**

This procedure is required only for stations in the following configurations:

- SPECTRA-TAC voting systems
- Digi-TAC voting systems
- IntelliRepeater stations

Status tone level alignment is used to set the analog monitor tone level for ASTRO systems using hybrid links.



**NOTE**

0 dB status tone is not supported by QUANTAR and Quantro stations.



### NOTE

Although status tones are not used in IntelliRepeater systems, status tone level equalization must be performed to allow system line tests.

1. Click **Tone On** to generate a 2175 Hz alignment status tone. Measure (in dBm) and record the value.
2. Click **Tone Off** near the bottom of the pane.
3. Subtract the absolute value measured in step 13 of Procedure B from the absolute value measured in step 1 of this procedure, and subtract 21.6 (for 13 dB status tone system) from the result. Enter the result in Status Tone Level Current field.

#### Example:

-22.8 dBm measured in step 13.

-31.9 dBm measured in step 1.

$$31.9 - 22.8 = 9.1$$

$$9.1 - 21.6 = -12.5$$

Enter -12.5 in Status Tone Level Current field.

4. After all equalization settings have been entered, click **Save** to save the values to non-volatile memory in the station.

## Procedure D: Optional Hi Boost Fine Tuning Procedure

The voting algorithm in a receiver voting system depends on the flatness of the received audio signal between 2000 Hz and 3000 Hz. This flatness is affected by the frequency and amplitude response of the phone lines between the receiver and the comparator.

There may be some cases where the Hi Boost equalization procedure (“Procedure B: Rx Wireline Equalization Alignment Procedure” on page 3-59) does not result in the optimum boost setting. This is usually indicated by a high amount of “wrong site” voting (resulting in poor audio quality).

If the system exhibits a significant amount of “wrong site” voting, first check the phone lines and ensure that they meet the required specifications. If within specifications, the following procedure is provided to allow you to fine tune the Hi Boost level setting to improve voting accuracy.

1. Click the **RX Wireline (Line 2)** tab. The Rx Wireline (Line 2) screen appears.



Reference Oscillator	TX Deviation	Power Output	RSSI Calibration
RX Wireline (line 4)	TX Wireline	Astro Simulcast Test Pattern	TDATA Calibration
Reference Modulation Compensation	Battery Equalization	Squelch Adjust	RX Wireline (line 2)
<input type="button" value="Tone On"/>		<b>Current</b> <b>RX Wireline Level (1 KHz)</b> -6.0 dBm <b>Peak Audio Level</b> -1.6 dBm	<b>Stored</b> -6.0 dBm
RX Wireline Equalization - Spectra/Digi/ASTRO-TAC			
<input type="button" value="Tone On"/>		<b>Current</b> <b>LO Boost Adjust Level @400 Hz</b> 0.0 dB	<b>Stored</b> 0.0 dB
<input type="button" value="Tone On"/>		<b>Current</b> <b>HI Boost Adjust Level @ 2500 Hz</b> 0.0 dB	<b>Stored</b> 0.0 dB
<input type="button" value="Set Freq"/>		<b>Current</b> <b>HI Boost Frequency</b> 2500 Hz	<b>Stored</b> 2500 Hz
<input type="button" value="Tone On"/>		<b>Current</b> <b>Status Tone Level Below Peak Audio</b> -13.0 dB	<b>Stored</b> -13.0 dB
		<b>Current</b> <b>Alert Tone Level Below Peak Audio</b> -10.0 dB	<b>Stored</b> -10.0 dB
		<input type="button" value="Tone Off"/> <input type="button" value="Save"/>	
<input type="button" value="Help"/>			
Station Note: Station is Currently ACCESS DISABLED Station Status: Not Keyed			

2. At the comparator, connect a high impedance AC voltmeter across the phone line input corresponding to the station/receiver being aligned.
3. Click **Tone On** for 2200 Hz and record the value displayed on the voltmeter.
4. Click **Tone Off**.
5. Click **Tone On** for 2500 Hz and record the value displayed on the voltmeter.
6. Click **Tone Off**.
7. Click **Tone On** for 2800 Hz and record the value displayed on the voltmeter.
8. Click **Tone Off**.
9. Calculate the mathematical average of the three voltmeter readings and compare the result to the value measured in step 13 of "Procedure B: Rx Wireline Equalization Alignment Procedure" on page 3-59.

**Example:**

2200 Hz Level: -21.9 dBm

2500 Hz Level: -22.8 dBm

2800 Hz Level: -23.7 dBm

Total = -68.4 dBm

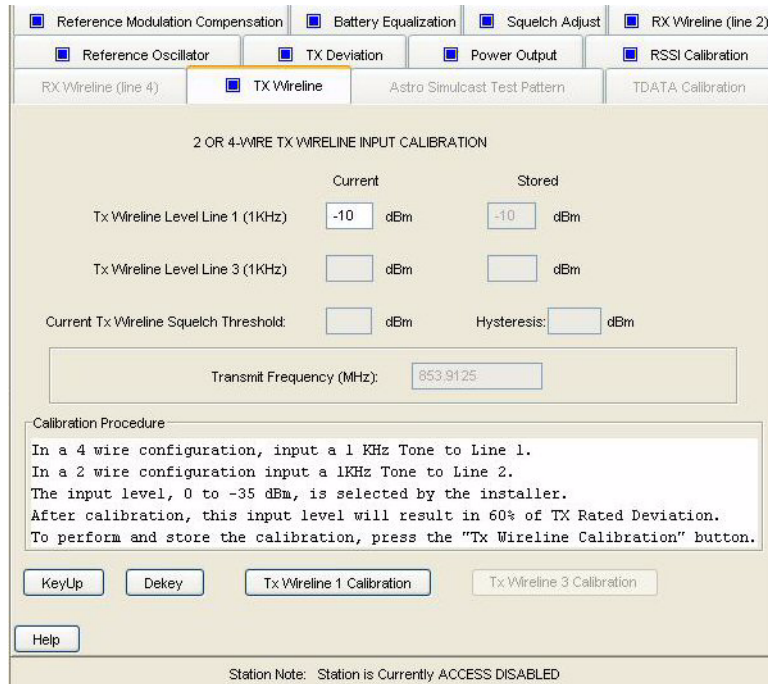
$-68.4 \div 3 = -22.8 \text{ dBm}$

- Because -22.8 dBm is equal to the value measured in step 13 of “Procedure B: Rx Wireline Equalization Alignment Procedure” on page 3-59, the equalization may be considered optimally set and no further action is required.
  - However, if the result in the above calculation is different than the value measured in step 13 of “Procedure B: Rx Wireline Equalization Alignment Procedure” on page 3-59, the Hi Boost Adjust Level, proceed to step 10.
10. Subtract the average, as calculated above, from the value measured in step 13 of “Procedure B: Rx Wireline Equalization Alignment Procedure” on page 3-59.
  11. Add the value from the previous step to the value currently displayed in the Hi Boost Adjust Level field. In this case:  
$$23.2 \text{ dBm} - 22.8 \text{ dBm} = 0.4 \text{ dBm}$$
$$0.4 \text{ dBm} + 4.7 \text{ dBm} = 5.1 \text{ dBm}$$
  12. Enter 5.1 in the Hi Boost Adjust Level current field.
  13. Click **Save**.
  14. Repeat steps 3 through 13 until the value measured in step 13 of “Procedure B: Rx Wireline Equalization Alignment Procedure” on page 3-59 and the average of the 2200, 2500, and 2800 Hz measurements are equal.  

If the preceding procedure does not produce an optimally equalized phone line, repeat the procedure using five evenly spaced alignment tones, such as 2200, 2350, 2500, 2650, and 2800 Hz.

## Procedure E: Aligning TX Wireline Procedure

1. If present, disconnect the phone line connected at the orange screw terminal, otherwise proceed to the next step.
2. If phone line connections have been made through the 50-pin Telco connector, disconnect it, otherwise proceed to the next step.
3. Click the **TX Wireline** tab. The TX Wireline screen appears.



4. Connect the signal generator to the station as shown in Figure 3-28.

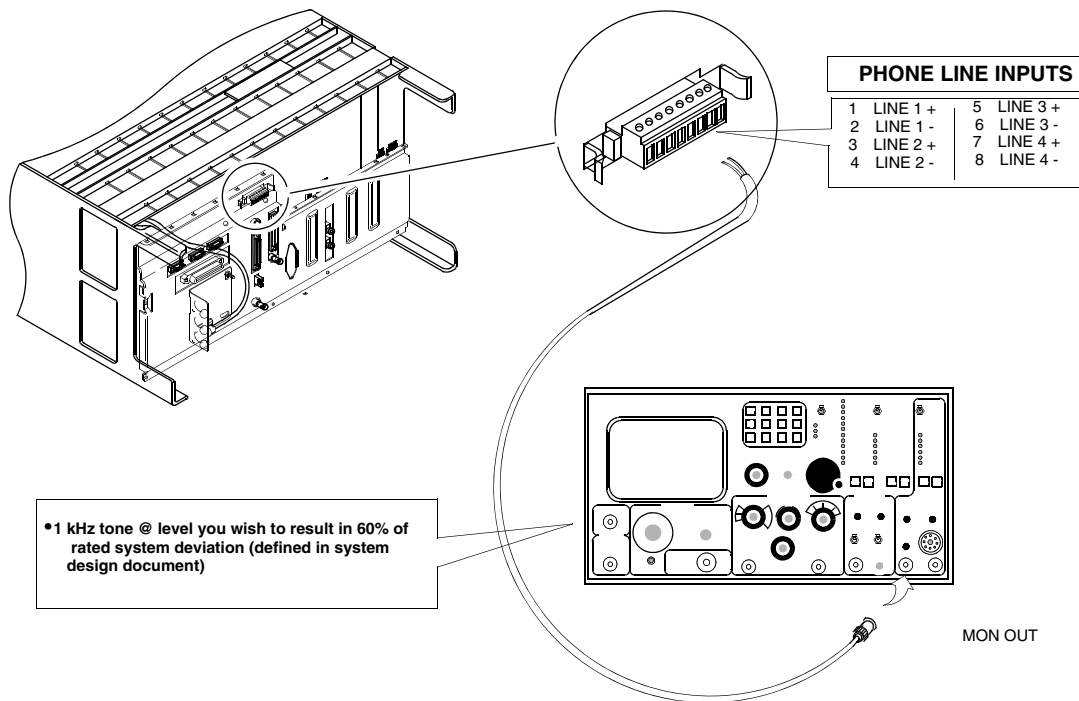


Figure 3-28 TX Wireline Alignment Setup

- For 2-wire audio circuits: Line 2 is used for both receive and transmit.
  - For 4-wire phone line circuits: Line 1 is used for transmit audio.
  - For 6-wire and 8-wire phone line circuits: Line 1 and Line 3 are used for transmit audio.
5. Click **Tx Wireline 1 Calibration**. The station automatically adjusts for the TX Wireline level and stores the value(s) in memory.

## Procedure F: Aligning ASTRO Link Management Tone Procedure

This procedure is required only for ASTRO stations with hybrid links, including conventional, 6809 trunking, and IntelliRepeater trunking.

1. Click **Rx Wireline (Line 2)** tab. The **Rx Wireline (Line 2)** screen appears.

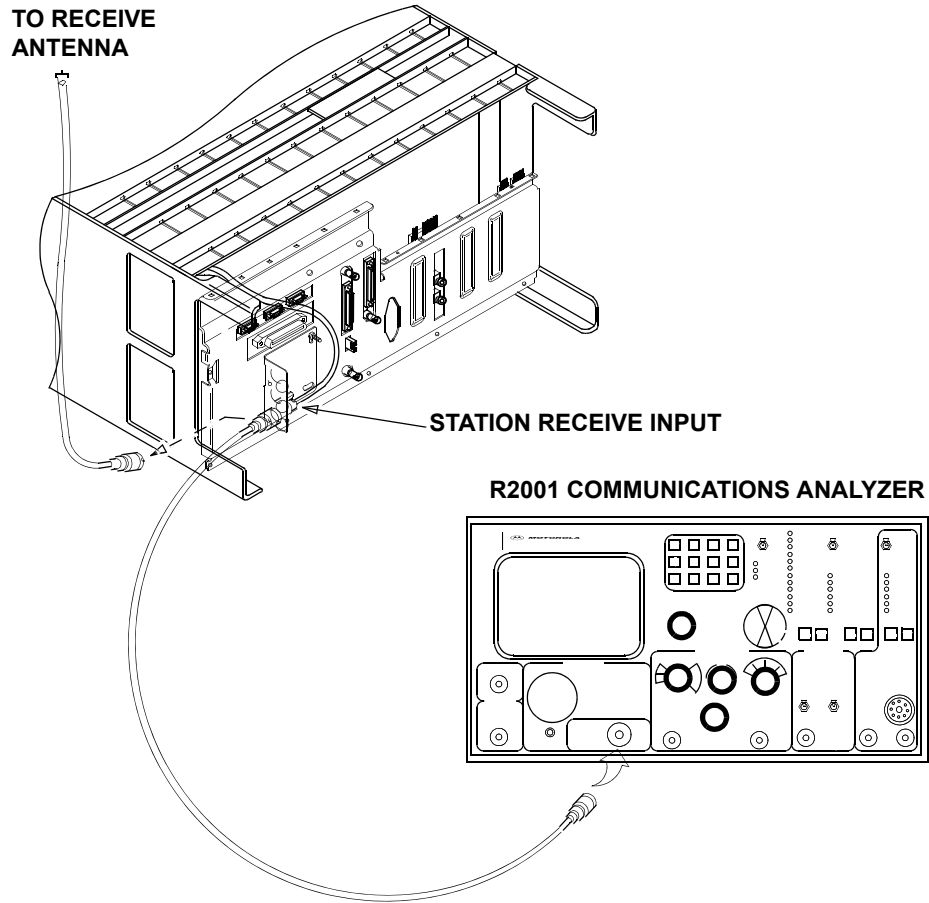
Setting	Current	Stored
RX Wireline Level (1 KHz)	-6.0 dBm	-6.0 dBm
Peak Audio Level	-1.6 dBm	
LO Boost Adjust Level @400 Hz	0.0 dB	0.0 dB
HI Boost Adjust Level @ 2500 Hz	0.0 dB	0.0 dB
HI Boost Frequency	2500 Hz	2500 Hz
Status Tone Level Below Peak Audio	-13.0 dB	-13.0 dB
Alert Tone Level Below Peak Audio	-10.0 dB	-10.0 dB

Station Note: Station is Currently ACCESS DISABLED  
Station Status: Not Keyed

2. Set the Status Tone Level as required by the System Installation Guidelines (typically -10 dBm). This example shows a setting of -13 dBm.

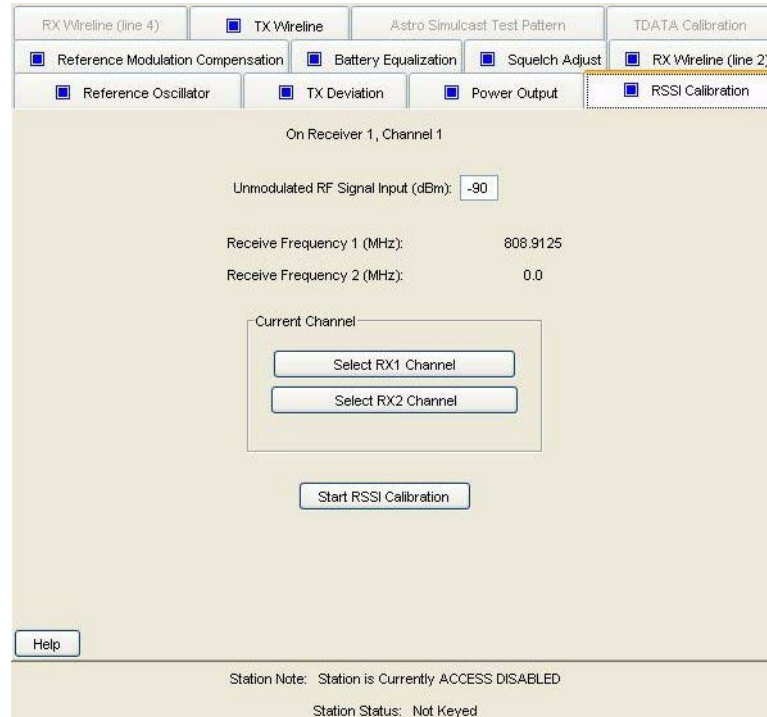
## Aligning Radio Signal Strength Indicator (RSSI)

1. Connect the station to the communications analyzer as shown in Figure 3-29.



**Figure 3-29** RSSI Alignment Test Setup

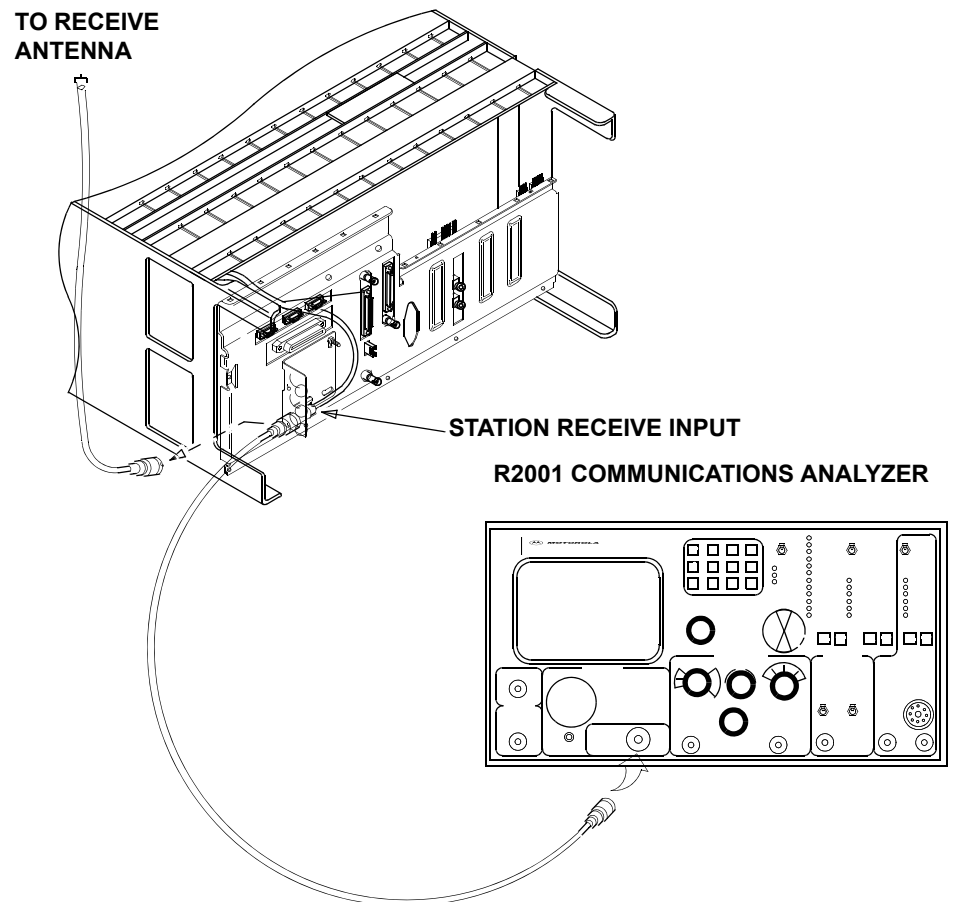
2. Click the **RSSI Calibration** tab. The RSSI Calibration screen appears.



3. Turn the communications analyzer on and set it as follows:
  - Generate
  - Frequency: Set the station's receive frequency
  - Output level: -90 dBm
  - Modulation: None
4. Click **Select RX1** Channel.
5. Click **Start RSSI Calibration**. The station automatically calibrates the receiver circuitry and stores the setting in station memory.
6. **If the station is equipped with two receiver modules:** Click **Select RX2** channel. **Otherwise:** you have completed this procedure.
7. Change the frequency on the communications analyzer to that of the second receive channel.
8. Click **Start RSSI Calibration**. The station automatically calibrates the receiver circuitry and stores the setting in station memory.

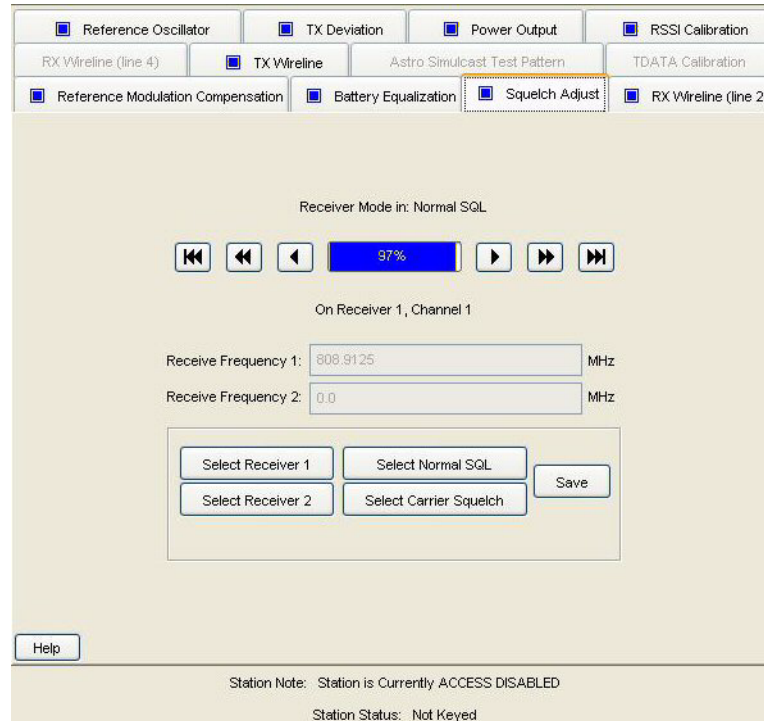
## Aligning Squelch Adjust Procedure

1. Connect the station as shown Figure 3-30.

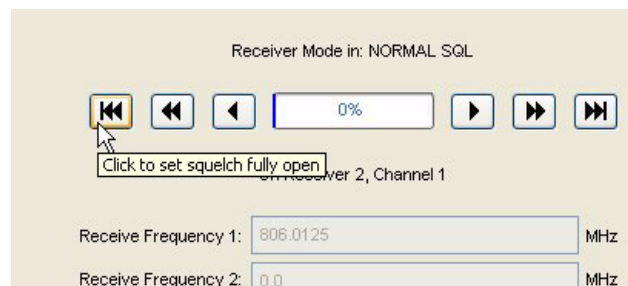


**Figure 3-30** Squelch Adjust Alignment Setup

2. Set the communications analyzer as follows:
  - **Frequency:** Set to the station's receive frequency.
  - **Output level:** Set as specified in the system design document. Typically, set to 12 dB SINAD or 20 dB quieting RF level.
  - **Modulation:** None
3. Click the **Squelch Adjust** tab. The Squelch Adjust screen appears.



4. Click **Select Receiver 1**.
5. Click the triple arrows pointing to the left to set the squelch to fully open.



6. Turn on the station's local speaker and verify that you can hear carrier noise.
  - If you hear carrier noise proceed to the next step.
  - If you do not hear carrier noise, resolve the problem before proceeding.
7. Use the right pointing arrows to set the squelch until the noise is squelched. Wait at least one second between each arrow click to allow the squelch circuitry to adjust.



#### NOTE

The single arrow moves the squelch by single units, the double arrow by 7 units, and the triple all the way to 100% (tight).



8. When the carrier noise is squelched, use the left pointing arrows to adjust the squelch toward “open” until carrier noise is again heard. Wait at least one second between each arrow click to allow the squelch circuitry to adjust.
9. Click **Save**. The squelch setting is saved to the station.
10. If the station has two receivers, click **Select Receiver 2** and perform steps 7 through 9. Otherwise squelch setting is complete.

**NOTE**

Trunking stations (IntelliRepeater or 6809 SMARTNET/SmartZone stations) must be configured for mixed mode, ANALOG/ASTRO CAI, operation in order for them to detect interfering carriers. The threshold for detecting the interfering carrier is set by performing the Carrier Squelch alignment. A station that is configured for ASTRO CAI only operation does not perform the carrier detect function properly.

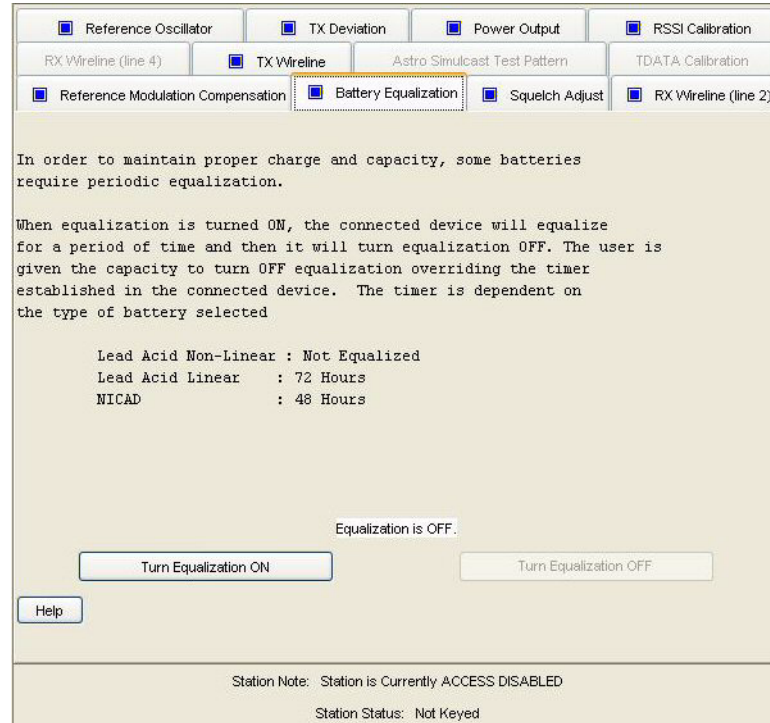
## Equalizing Batteries

Sites equipped with storage batteries to provide station power in case of primary power failure require the battery cells be equalized periodically. It is recommended that the batteries be equalized at the time of installation, and henceforth according to the schedule recommended by the battery manufacturer.

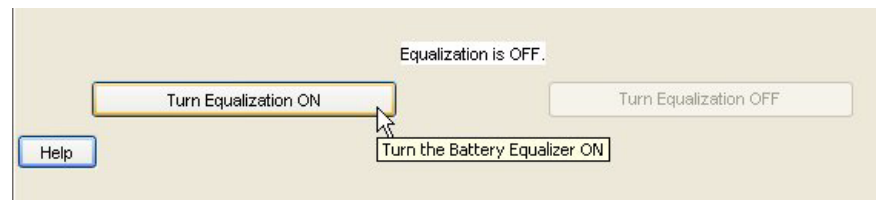
Battery equalization is a process under which the charging voltage to the batteries is slightly boosted for a period of time, typically 48 hours to 72 hours. This slight overcharging causes the individual cells to regenerate equally and provide nearly identical output voltages.

### For QUANTAR Stations:

1. Click the **Battery Equalization** tab. The Battery Equalization screen appears.

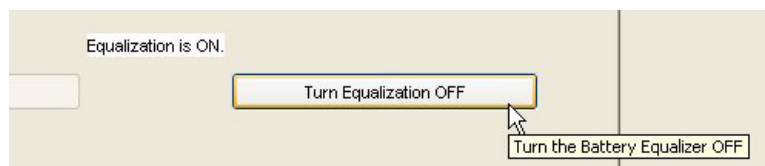


2. Click **Turn Equalization On** to start the process.



The station power supply boosts battery charging voltage slightly for a period of time determined by the type of batteries being used, as specified in the Hardware Configuration screen. A timer in the station controls the length of time that the boosted charging voltage is applied and automatically sets the charging voltage to its normal level when the timer expires.

3. If you must stop the process manually, click **Turn Equalization Off**.



## For Quantro Stations:



### NOTE

Battery equalization for Quantro stations is performed manually. To equalize the batteries in a Quantro station, perform the following procedure:

1. Toggle the **Float/Equalize** switch located on the power supply control board to the Equalize position.
2. Time the boosted charging period yourself.
3. When the appropriate time has expired, toggle the switch to the **Float** position.

## Calibrating Reference Oscillator Procedure

The circuit device(s) that set the station's reference frequency exhibit slight variations in operating characteristics over time. Approximately 90% of these variations occur in the first year, whether the station is in-service or in storage and non-operational. Therefore, it is necessary to calibrate the reference oscillator during optimization.

It is recommended that the frequency measurement equipment has an accuracy 10 times greater than the accuracy required for the measurement. For example, if the frequency must be measured to within  $\pm 5$  pulses per minute (PPM), the accuracy of the measurement equipment should be  $\pm 0.5$  PPM.

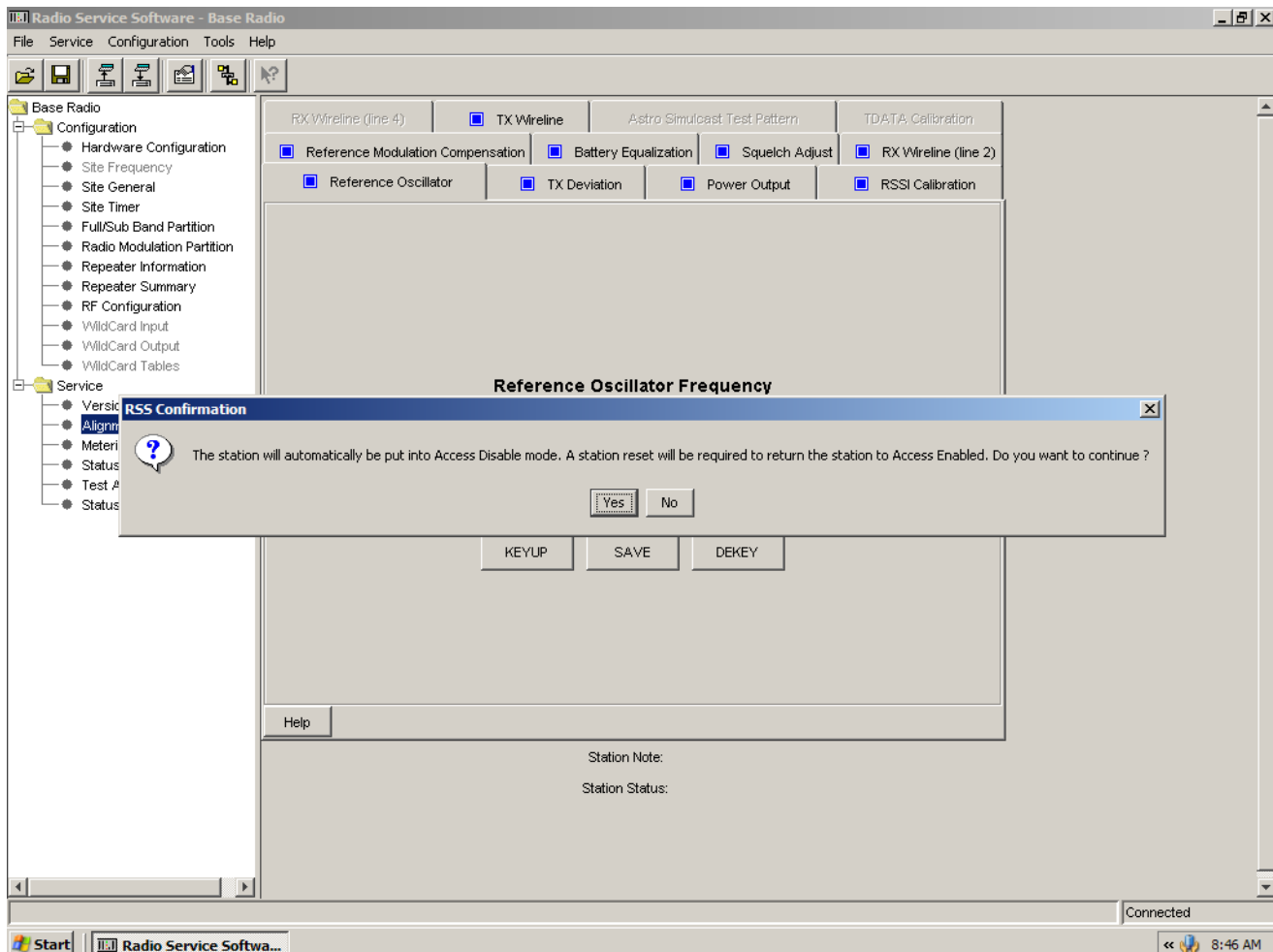
The reference oscillator calibration procedure depends on the station configuration. Currently, there are three possible configurations. Perform the calibration procedure that corresponds to the station's configuration:

- Internal reference oscillator (located on the station control board):
  - "Reference Oscillator Calibration: Internal Reference Oscillator - Manual Procedure" on page 3-75, or
  - "Reference Oscillator Calibration: Internal Reference Oscillator - Auto-Net Procedure" on page 3-77
- External source, typically 5 MHz: "Reference Oscillator Calibration: External Reference Oscillator" on page 3-78
- UHSO (option X873AA): "Reference Oscillator Calibration: Internal Ultra High Stability Oscillator (UHSO)" on page 3-78

### Reference Oscillator Calibration: Internal Reference Oscillator - Manual Procedure

1. Set up the station and R2001 analyzer with an external frequency standard to measure the station's transmitter frequency.
2. Disconnect the station's receive antenna cable.
3. Launch the RSS program as outlined in "Launching the RSS Program" on page 2-12.

4. Read the station's codeplug as outlined in "Reading the Device Codeplug" on page 2-14. You are now connected to the station.
5. Click the + sign next to Service to expand the Service menu.
6. Click **Alignment Screen** in the navigation pane.



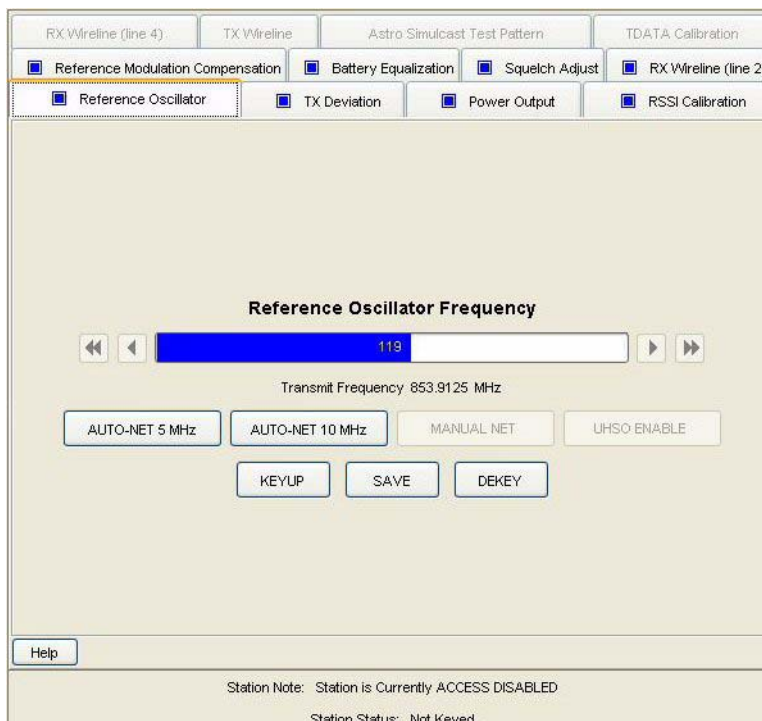
7. Click **Yes** to continue.



#### NOTE

When the alignment procedures are completed, deactivate Access Disable and restore the station to normal operation by performing a station reset.

The Reference Oscillator Alignment screen appears.

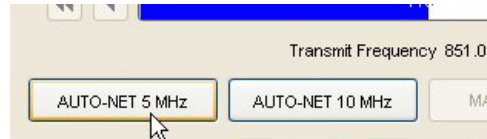


Generally, the Reference Oscillator screen appears as the default screen as shown above.

8. Observe the frequency reading on the R2001 analyzer as you click **Keyup** to key the station transmitter.
  - If the observed transmit frequency reading is not the same as that specified by the FCC for that station, adjust the internal reference oscillator using the right or left arrows on either side of the Reference Oscillator Frequency graph until you obtain a reading on the analyzer as close as possible to the FCC-specified transmit frequency for that station.
  - If the observed reading equals that specified by the FCC for that station, no changes are required.
9. Click **Dekey** to dekey the station.
10. If you adjusted the reference oscillator frequency, click **Save** to save the reference oscillator value. Otherwise, this procedure is complete. Disconnect the test equipment.

### Reference Oscillator Calibration: Internal Reference Oscillator - Auto-Net Procedure

1. Connect the output of a stable 5 MHz or 10 MHz reference source to the BNC connector located at the bottom of the station control module front panel.
2. Set the frequency source for  $1.0 \pm 0.5V$  RMS output.
3. Click either **Auto-Net 5 MHz** or **Auto-Net 10 MHz**, depending on the reference in use, to begin the calibration process using the test reference source. The status area of the screen displays the progress.



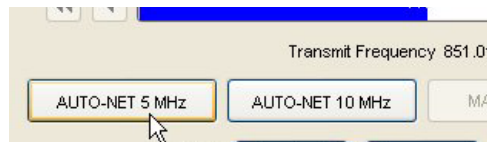
4. When the process is complete, close the Completed Successfully message window. The oscillator adjustment data is saved to the station codeplug and the station dekeys.

## Reference Oscillator Calibration: External Reference Oscillator

This procedure is required only if the station transmitter and/or receiver do not lock, as indicated by the Tx Lock LED off or the Rx Fail LED lit when the external source is present and on.

The accuracy of this procedure depends on the accuracy of the external source. Ensure that the 5 or 10 MHz source provides the required accuracy, as defined in Table 1 in the Routine Maintenance section of the relevant functional manual for the station.

1. Connect the output of the stable 5 or 10 MHz external reference source to either the BNC connector located at the bottom of the station control module front panel or the BNC connector located on the station backplane.
2. Click either **Auto-Net 5 MHz** or **Auto-Net 10 MHz**, depending on the reference in use, to begin the calibration process using the test reference source. The status area of the screen displays the progress.



3. When the process is complete, close the Completed Successfully message window. The oscillator adjustment data is saved to the station codeplug and the station dekeys.

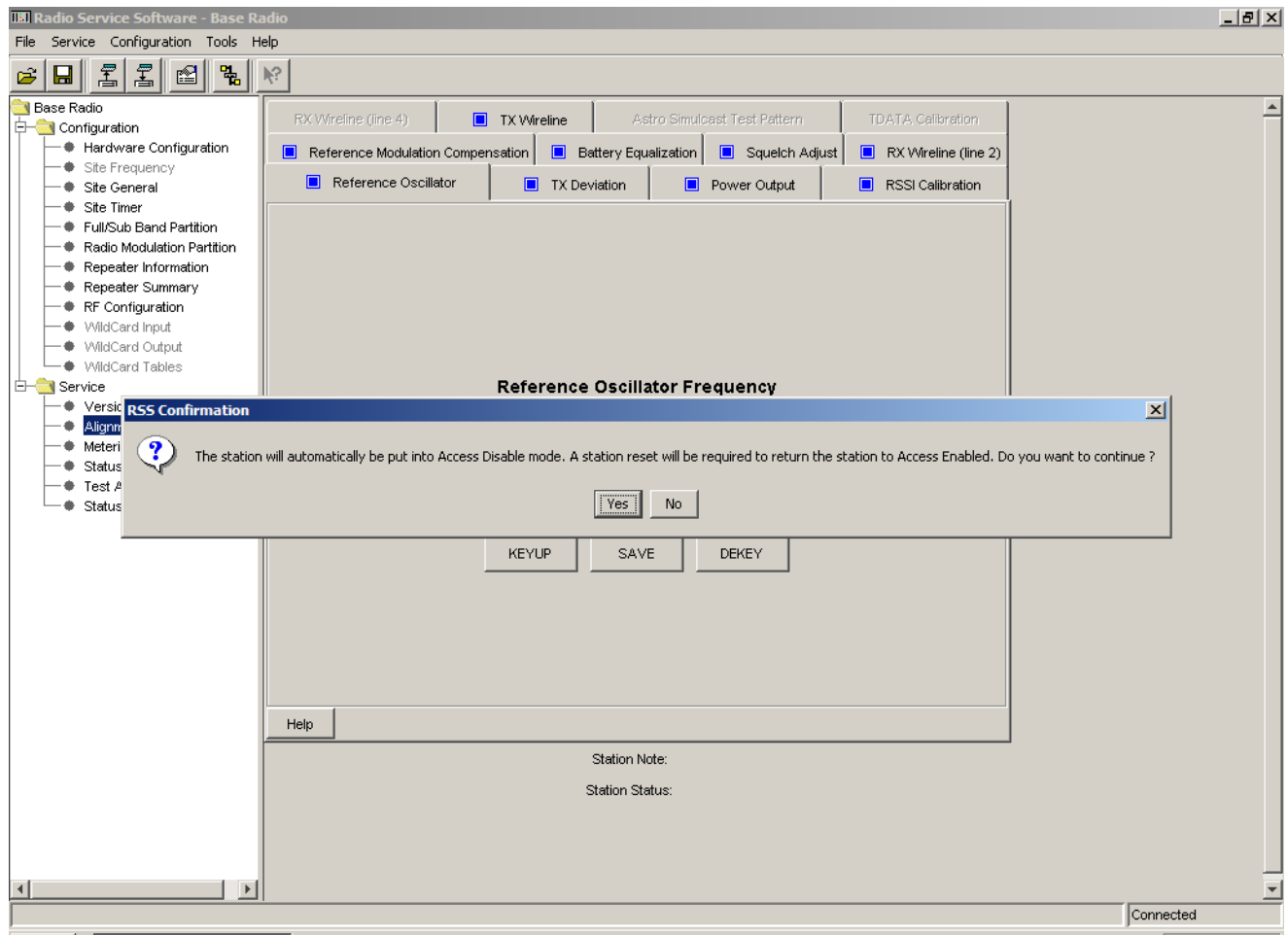
## Reference Oscillator Calibration: Internal Ultra High Stability Oscillator (UHSO)

This procedure is required only if the station transmitter and/or receiver do not lock, as indicated by the Tx Lock LED being off or the Rx Fail LED lit when the UHSO source is present and on.

The accuracy of this procedure depends on the accuracy of the external source. Ensure that the 5 or 10 MHz source provides the required accuracy, as defined in Table 1 in the Routine Maintenance section of the relevant functional manual for the station.

1. Set up the station and R2001 analyzer with an external frequency standard to measure the station's transmitter frequency.
2. Turn the station on and allow it to warm up for about 60 minutes.
3. Launch the RSS program as outlined in "Launching the RSS Program" on page 2-12.
4. Read the station's codeplug as outlined in "Reading the Device Codeplug" on page 2-14. You are now connected to the station.

5. Click the + sign next to Service to expand the Service menu.
6. Click **Alignment Screen** in the navigation pane.



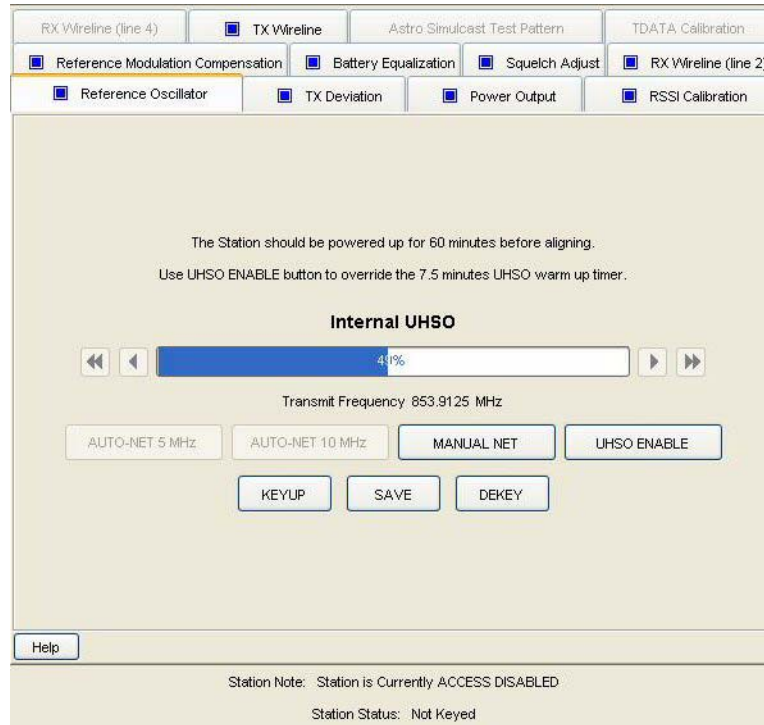
7. Click **Yes** to continue.



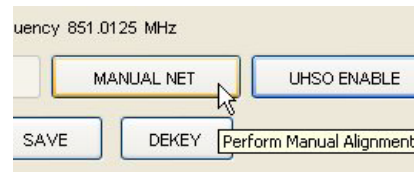
#### NOTE

When the alignment procedures are completed, deactivate Access Disable and restore the station to normal operation by performing a station reset.

The Reference Oscillator Alignment screen appears.

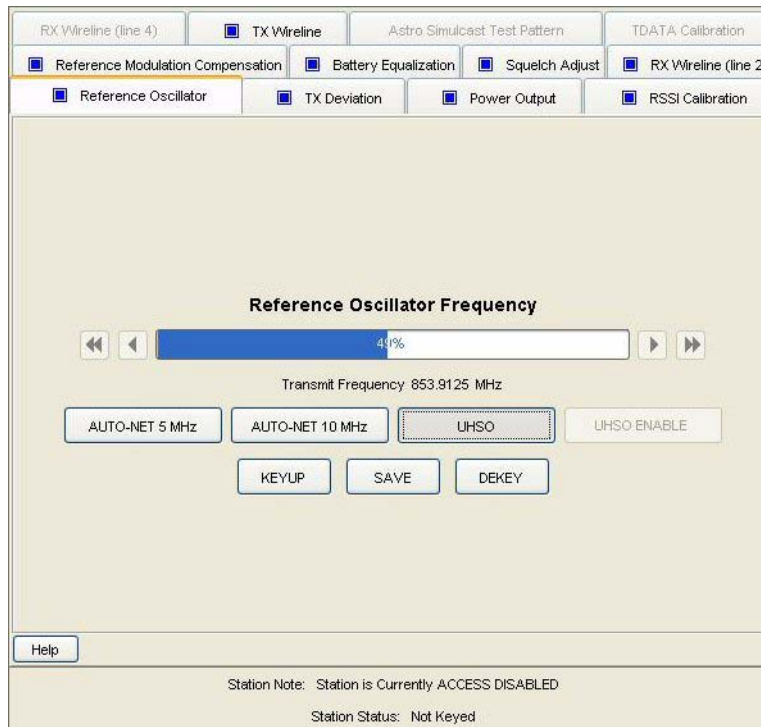


8. If the station transmitter and/or receiver do not lock, as indicated by the Tx Lock LED being off or the Rx Fail LED lit when the UHSO source is present and on, click **Manual Net**. Otherwise proceed to step 12.

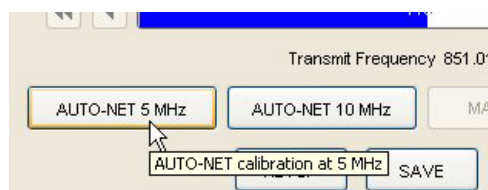


The following screen appears.





9. Connect the output of the stable 5 or 10 MHz external reference source to either the BNC connector located at the bottom of the station control module front panel, or to the BNC connector located on the station backplane.
10. Click either **Auto-Net 5 MHz** or **Auto-Net 10 MHz**, depending on the reference in use, to begin the calibration process using the test reference source. The status area of the screen displays the progress.



11. When the process is complete, close the Completed Successfully message window. The oscillator adjustment data is saved to the station codeplug and the station dekeys. If the internal reference oscillator has been calibrated, proceed to the next step.
12. Click **Keyup** to key the station.
13. While observing the R2001 analyzer display, adjust the station's reference oscillator using the left or right arrows until the R2001 displays the specified FCC transmit frequency.
14. Click **Save** to save the setting in the station.
15. Click **Dekey** to dekey the station.

## Setting ASTRO Tx Align and Test Procedure



### NOTE

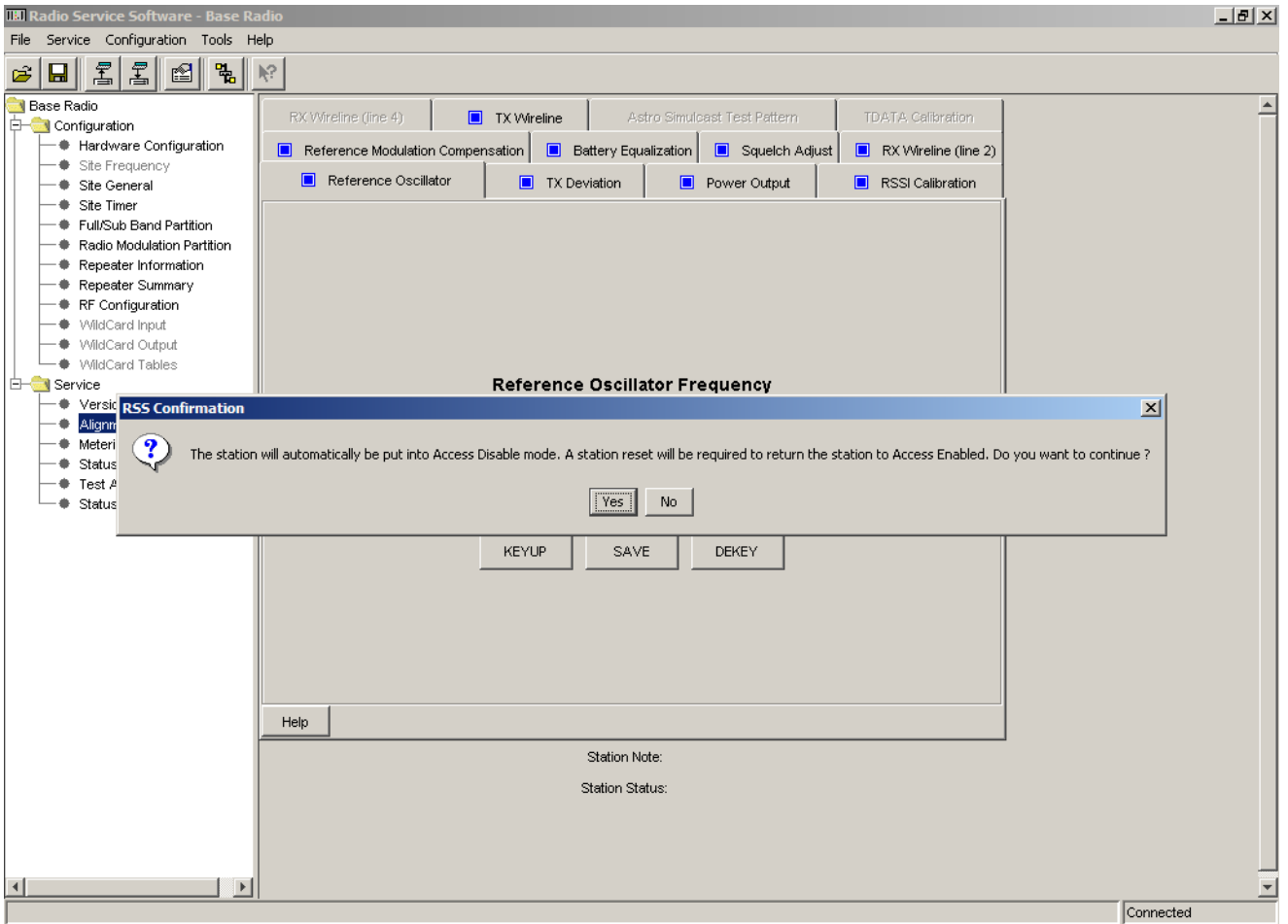
This procedure applies only to conventional and 6809 trunking stations.

In an ASTRO simulcast system, all station transmitters are synchronized to a 1 pulse per second (pps) signal from a global positioning satellite (GPS) receiver. The 1 pps signal provides a common time reference for each of the transmitters. The ASTRO signaling information arriving at the station transmitter includes timestamps that specify the launch time for the voice and data transmissions.

In any simulcast system, small zones of poor subscriber reception (nulls) may occur in the overlapping coverage areas from multiple transmitters. Fine adjustment of the launch time from one specific transmitter site or a combination of sites can be used to fill in these null zones. Fine launch time adjustments can also be used to compensate for GPS 1 pps propagation variations (due to factors such as cable lengths).

Because the launch timestamps permit only 20  $\mu$ s resolution, the ASTRO Alignment and Test alignment screen is provided to allow you to specify a value with 0.1  $\mu$ s resolution that is added to the arriving timestamp value to provide an adjusted launch time. The specified ASTRO simulcast launch time offset value applies only to ASTRO simulcast systems and is considered optional. The factory default offset value is 0 (zero), causing no adjustment to the launch time specified by the arriving timestamp value.

1. Launch the RSS program as outlined in “Launching the RSS Program” on page 2-12.
2. Read the station’s codeplug as outlined in “Reading the Device Codeplug” on page 2-14. You are now connected to the station.
3. Click the + sign next to Service to expand the Service menu.
4. Click **Alignment Screen** in the navigation pane.



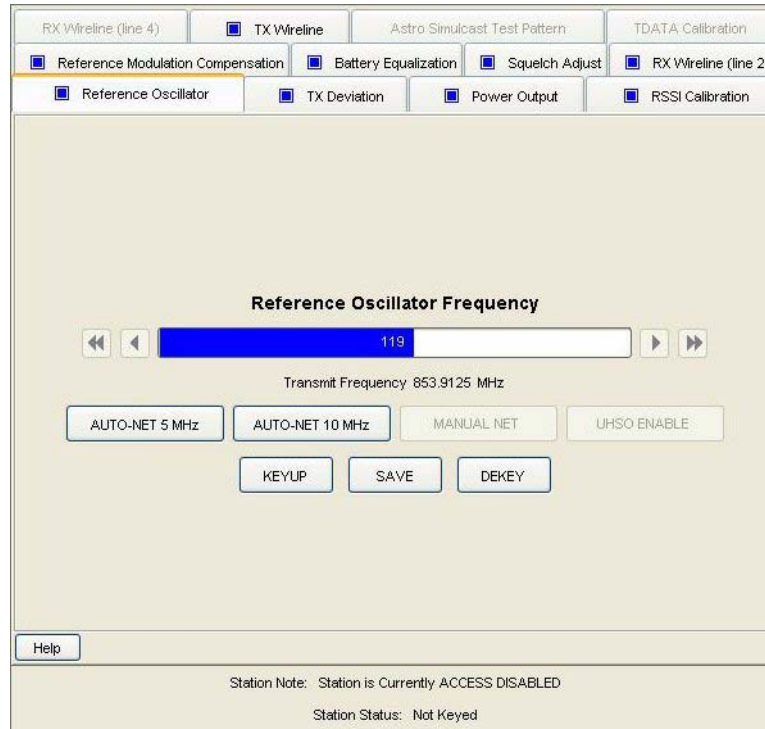
5. Click **Yes** to continue.



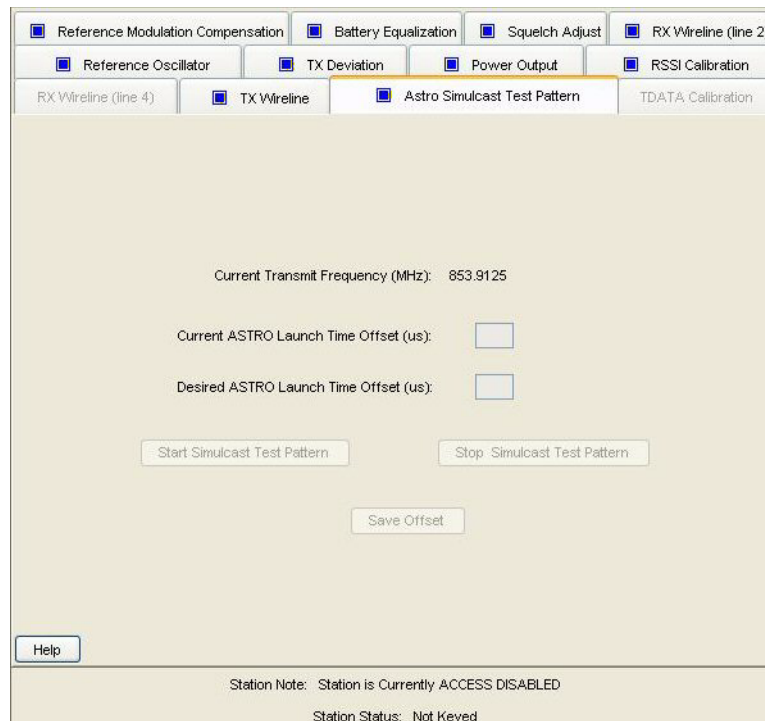
**NOTE**

When the alignment procedures are completed, deactivate Access Disable and restore the station to normal operation by performing a station reset.

The Reference Oscillator Alignment screen appears.



6. Click the **ASTRO Simulcast Test Patterns** tab. The ASTRO Simulcast Test Patterns screen appears.



7. Enter the desired offset value (0.1  $\mu\text{s}$  resolution) in the **Desired ASTRO Launch Time Offset ( $\mu\text{s}$ )** field. The current value is shown in the **Current ASTRO Launch Time Offset ( $\mu\text{s}$ )** field.
8. Click **Save Offset**.
9. Click **Reset Station** to activate the new offset value.



#### NOTE

Within a particular ASTRO simulcast system, in order to operate stations running release R10.05.00 (or later) with stations running release R10.04.00 (or later), you must add 208  $\mu\text{s}$  to the offset value entered in step 7 in each station running release R10.05.00 (or later). This compensates for an internal 208  $\mu\text{s}$  transmit delay in earlier stations and allows newer and older stations to operate within the same ASTRO simulcast system.

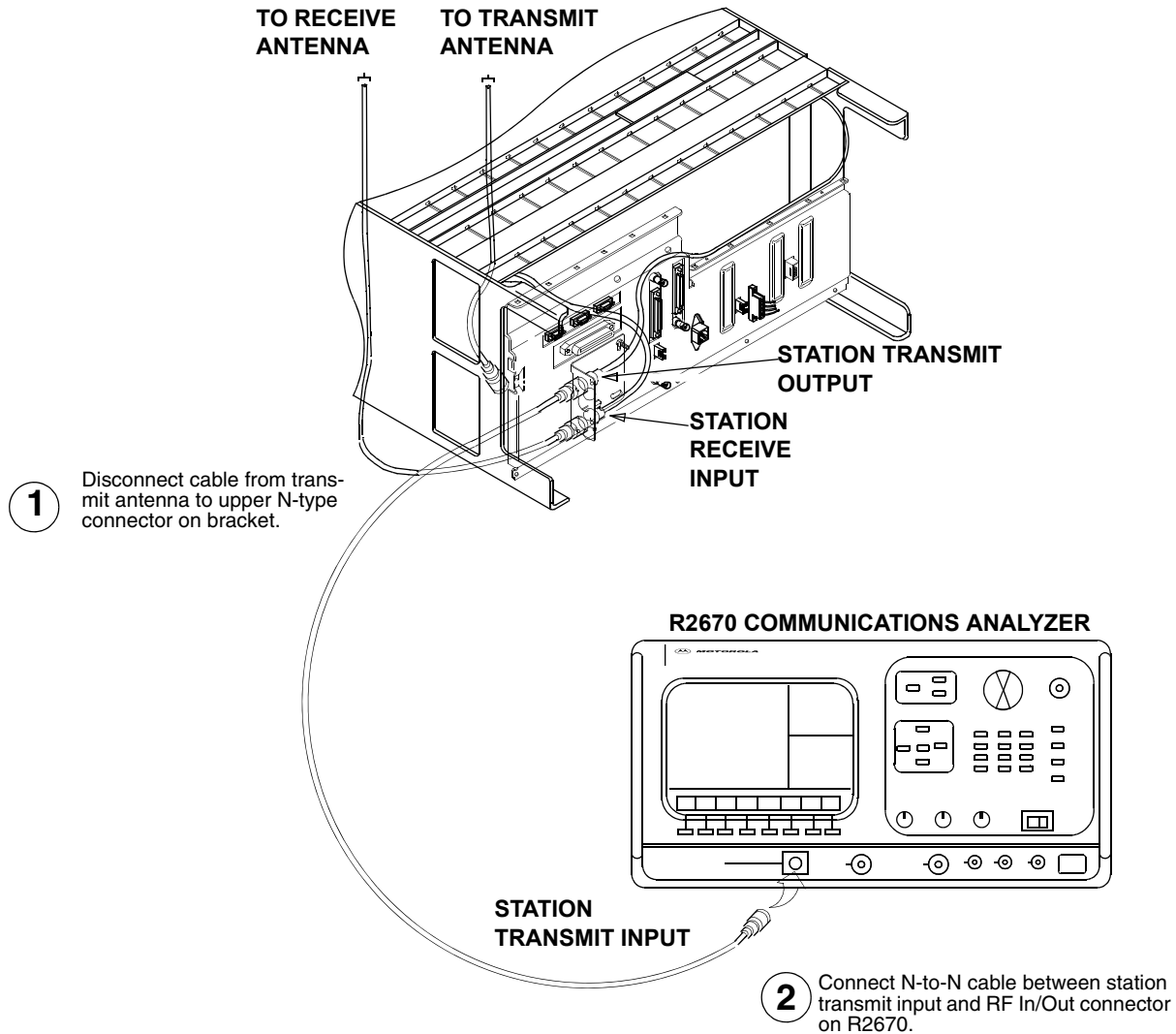
## Generating ASTRO Test Patterns

The station is capable of generating any of the following four test patterns:

- Standard transmitter symbol rate (STD DEV)
- Standard transmitter low deviation (LOW DEV)
- V.52 Deviation
- Standard transmitter C4FM modulation (C4FM)

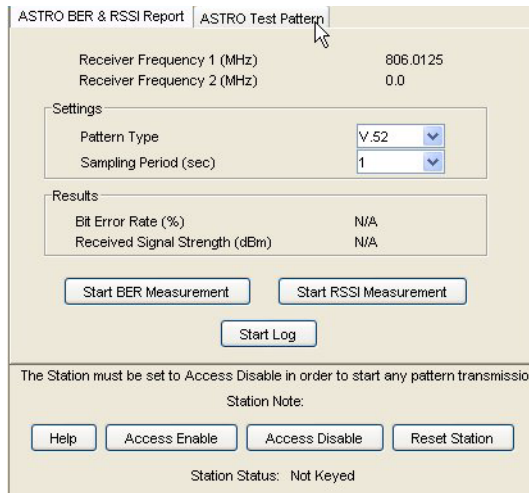
By causing the station to generate these tones and then viewing them on an R2670 analyzer, you may verify that the station is compliant with ASTRO Project 25 signaling specifications.

1. Connect the station and R2670 analyzer as shown in the following figure.

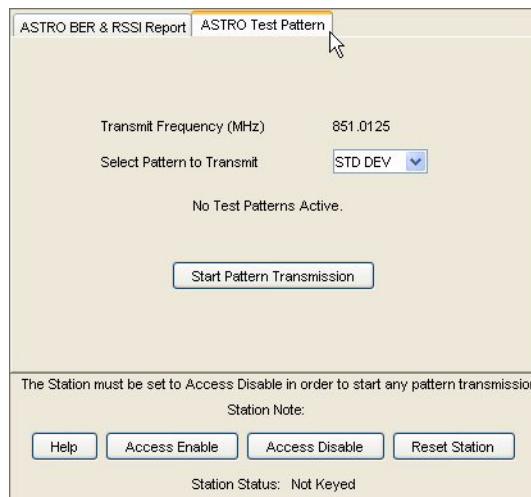


2. Launch the RSS program as outlined in “Launching the RSS Program” on page 2-12.
3. Read the station’s codeplug as outlined in “Reading the Device Codeplug” on page 2-14. You are now connected to the station.
4. Click the + sign next to Service to expand the Service menu.

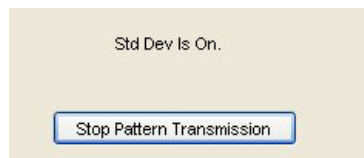
5. Click **Test and Measurement Screen** in the navigation pane. The following Test and Measurement screen appears.



6. Click the **ASTRO Test Patterns** tab. The following ASTRO Test Patterns screen appears.



7. Select the desired pattern from the **Select Pattern to Transmit** list.
8. Click **Start Pattern Transmission** to transmit the selected pattern. The screen indicates that the test pattern is now on.

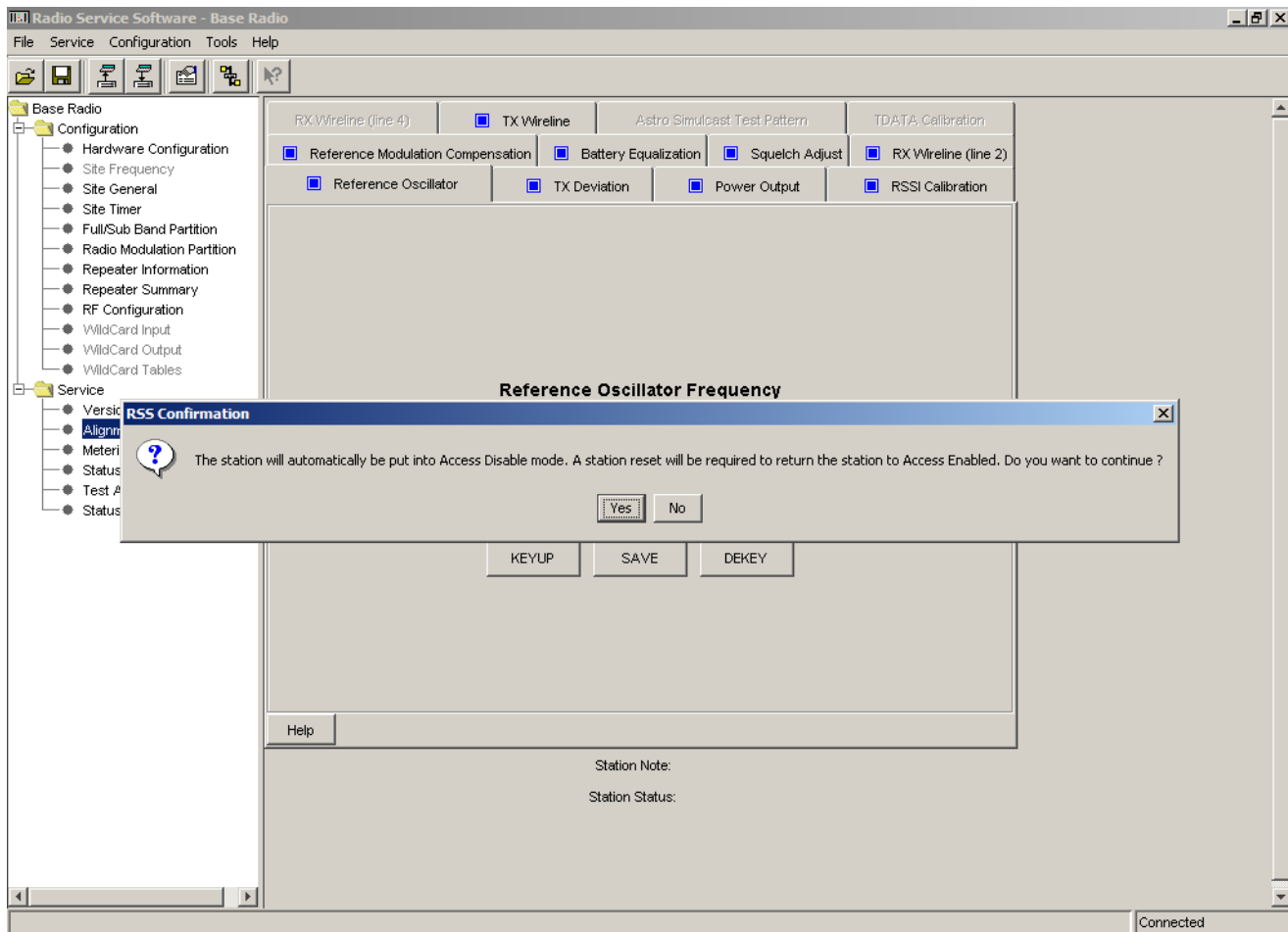


9. Observe the pattern on the R2670 display. Compare the pattern's deviation with that specified in the Help file by clicking **Help**.

- If it matches the specified deviation, proceed to step 10.
  - If it does not match the specified deviation, troubleshoot and repair.
10. Click **Stop Pattern Transmission** to stop the transmission.
  11. If required to select another pattern, proceed to step 7 and repeat steps 7 through 10. Otherwise, the procedure is complete. Disconnect the test equipment.

## TDATA Calibration (6809 Trunking Station Only)

1. Launch the RSS program as outlined in “Launching the RSS Program” on page 2-12.
2. Read the station’s codeplug as outlined in “Reading the Device Codeplug” on page 2-14. You are now connected to the station.
3. Click the + sign next to Service to expand the Service menu.
4. Click **Alignment Screen** in the navigation pane.



5. Click **Yes** to continue.

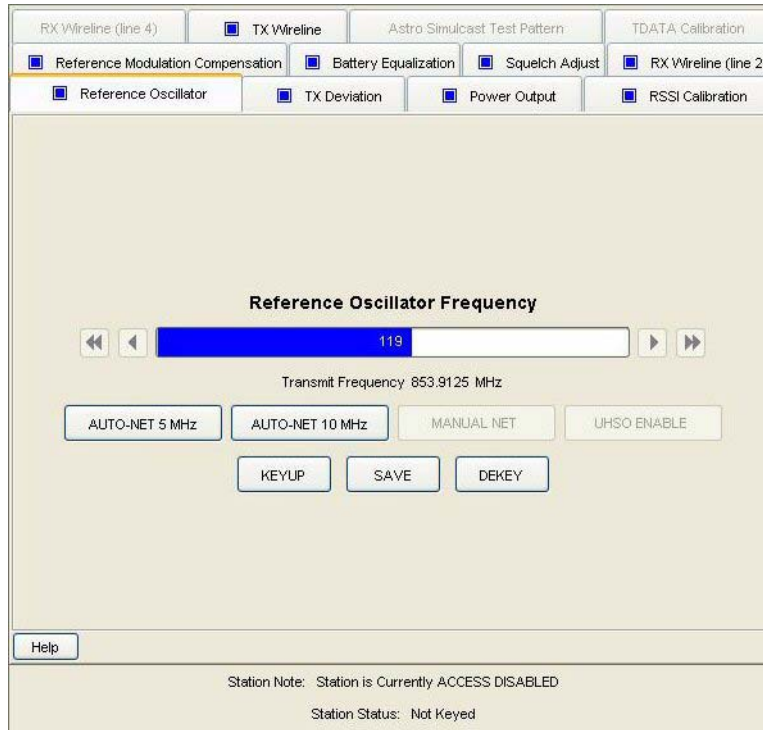




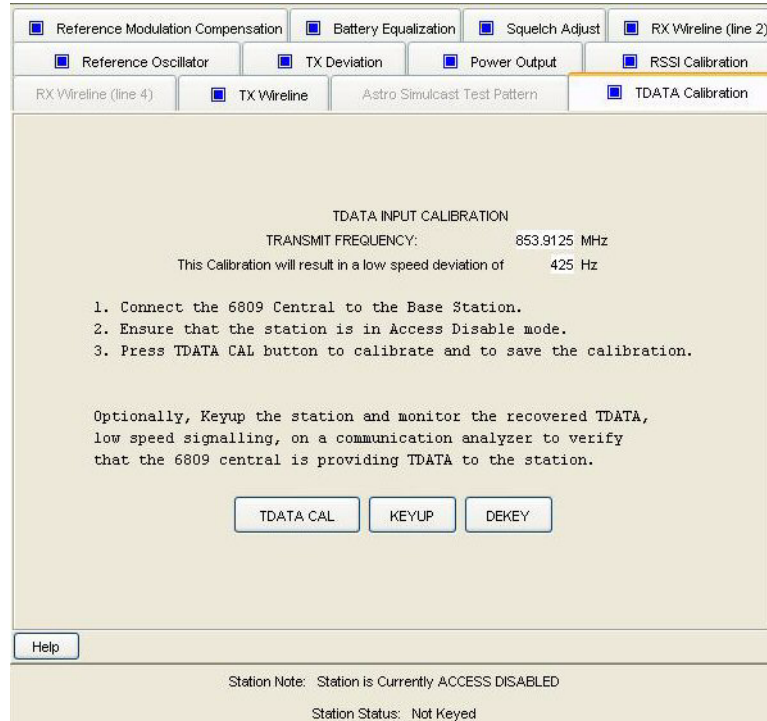
**NOTE**

When the alignment procedures are completed, deactivate Access Disable and restore the station to normal operation by performing a station reset.

The Reference Oscillator Alignment screen appears.



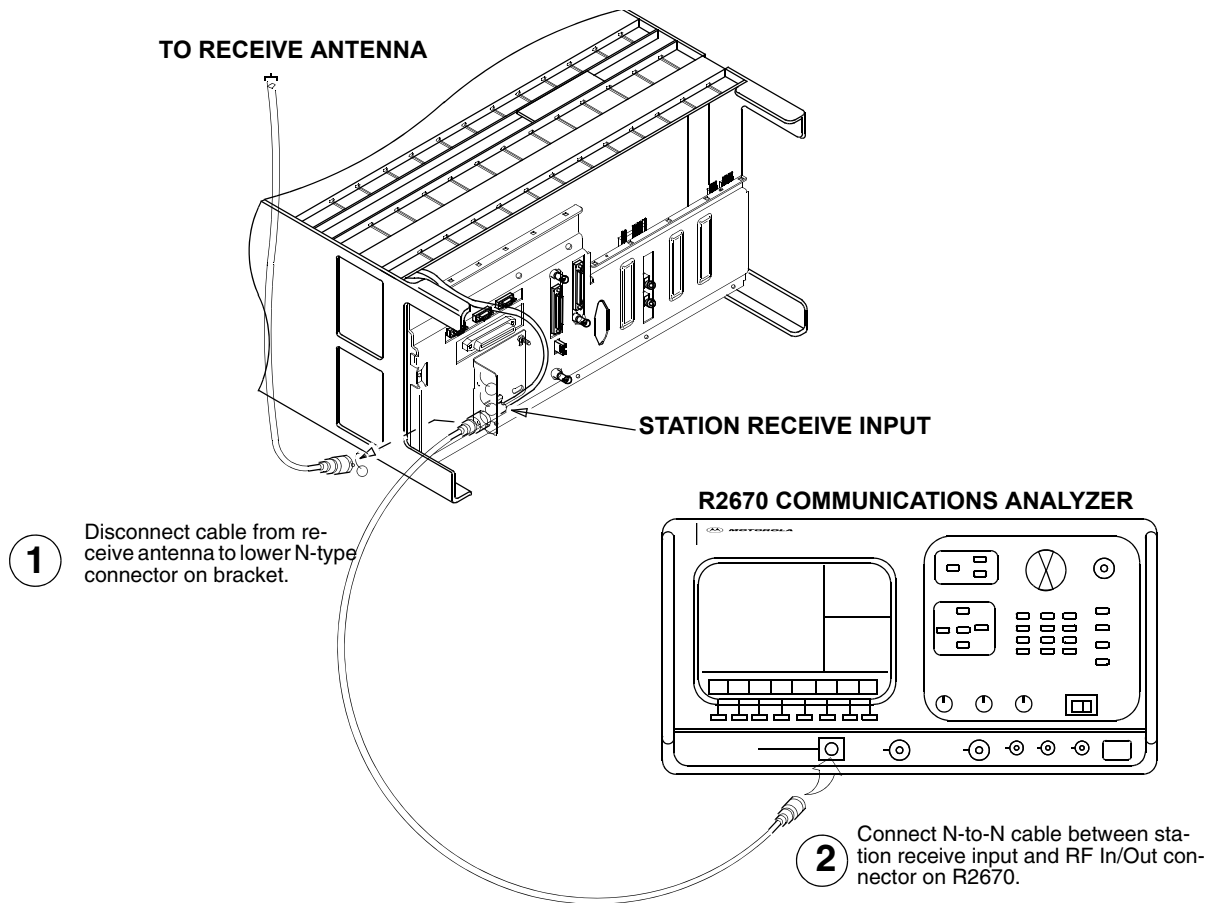
6. Click the **TDATA Calibration** tab. The TDATA Calibration screen appears.



7. Follow the instructions on the screen. Note that the low speed deviation (shown as 850 Hz above) is determined by the setting of the low speed deviation data field on the RF Configuration screen.

## ASTRO Bit Error Rate Reports

1. Connect the station and R2670 analyzer.



2. Set the R2670 as follows:
  - Frequency: Set to station's Rx frequency
  - Output level: 0.5  $\mu$ V (-113 dBm)
  - Modulation: V.53 or Project 25 1011 Pattern, as applicable
3. Launch the RSS program as outlined in "Launching the RSS Program" on page 2-12.
4. Read the station's codeplug as outlined in "Reading the Device Codeplug" on page 2-14. You are now connected to the station.
5. Click the + sign next to Service to expand the Service menu.
6. Click **Test and Measurement Screen** in the navigation pane. The Test and Measurement screen appears.

ASTRO BER & RSSI Report | ASTRO Test Pattern

Receiver Frequency 1 (MHz) 806.0125  
Receiver Frequency 2 (MHz) 0.0

Settings

Pattern Type V.52  
Sampling Period (sec) 1

Results

Bit Error Rate (%) N/A  
Received Signal Strength (dBm) N/A

Start BER Measurement Start RSSI Measurement  
Start Log

The Station must be set to Access Disable in order to start any pattern transmission

Station Note:

Help Access Enable Access Disable Reset Station

Station Status: Not Keyed

7. Select either **V.52** or **Project 25** from the Pattern Type list, as applicable.
8. Click either **Start BER Measurement** or **Start RSSI Measurement**, as applicable. One of the following screens appear with measurement values for the following:
  - Absolute RSSI (dBm)
  - Relative RSSI (dB)
  - Bit Error Rate %

## Post-Optimization Checkout

---

After optimizing the equipment at a new installation, you should perform some basic tests to verify that the equipment is functioning properly within the system.

- Perform Station Diagnostics

Diagnostics are run continuously on the station. If errors are detected, they are logged to the Status Report. Check the Status Report for errors.

- Frequency, Deviation, and Output Power

Using standard measuring methods, verify that the station meets specifications for frequency, deviation, and output power.

- Place Call to Subscriber

Plug a handset with Push-To-Talk (PTT) into the handset RJ-11 jack located on the front panel of the station control module. Place a call to a subscriber unit located a reasonable distance from the site. You should be able to talk and listen in simplex mode using the handset and PTT switch. This verifies all operating functions of the station that are included in the RF link, such as the receiver, power amplifier, exciter, and antenna system, and certain audio circuits in the station control module.

- Place Call to Console

For analog only conventional stations that are connected to a remote console, establish communications using the intercom pushbutton located on the front panel of the station control board and a handset or microphone. This test verifies proper operation of the wireline circuitry, phone lines, and certain audio circuits in the station control module.

**THIS PAGE INTENTIONALLY LEFT BLANK.**

# Optimizing the ASTRO-TAC Comparator

---

ASTRO-TAC comparators must be optimized after they are initially installed and after maintenance actions such as retuning or replacing modules. Optimization includes tasks such as verifying the comparator hardware configuration, performing alignment, and programming the comparator's codeplug. The general process for optimizing a base comparator is as follows:

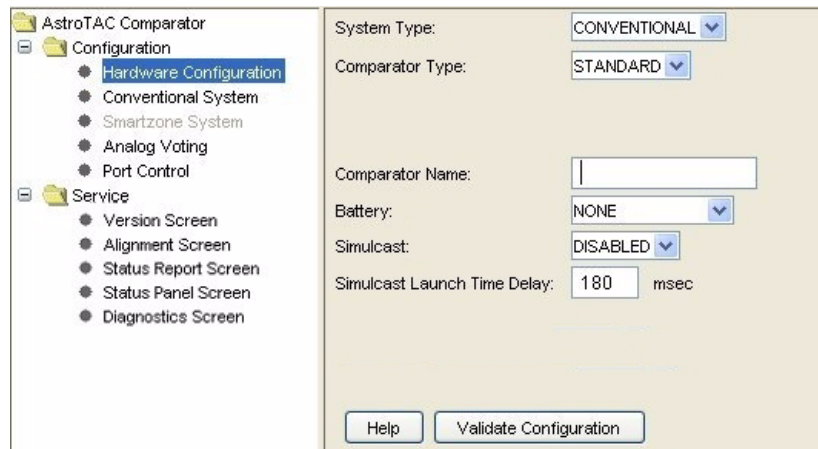
1. Connect the RSS computer to the comparator. See “Connecting the PC to the Device RSS Port” on page 2-11.
2. Launch the RSS program as outlined in “Launching the RSS Program” on page 2-12.
3. Read the comparator's codeplug. See “Reading the Device Codeplug” on page 2-14.
4. Verify that the comparator's configuration data, as sent from Motorola, is as specified in the purchase order. See “Verifying the Comparator's Configuration Data” on page 4-2.
5. Customize the codeplug for the comparator's specific installation if required. See the following as required for the specific system:
  - “Programming the IP Address” on page 3-6
  - “Programming the MAC Address” on page 3-7
  - “Setting the Device's Date and Time” on page 3-8
  - “Creating the Station's Password” on page 8-2
  - “Programming the Comparator” on page 4-3
6. Save the updated configuration data to a file on the RSS computer as an archive of the comparator's current configuration as outlined in “Saving Configuration Data to an Archive File” on page 2-22.
7. Save the updated configuration data to the comparator's codeplug as outlined in “Writing Codeplug Data to the Device” on page 2-20.

# Verifying the Comparator's Configuration Data

Each comparator ships from Motorola's factory with a codeplug that has been custom programmed based on information on the sales order. A portion of the comparator codeplug data includes definitions of the comparator hardware configuration, including serial number, ID, types of modules installed, and system and modulation type. It is recommended that you use the RSS to view this data to ensure that it agrees with the equipment you are currently optimizing. Also verify that the equipment configuration agrees with the "vend ticket" shipped with the equipment.

To access the connected comparator's current configuration data, perform the following procedure:

1. Click the + sign on the Configuration node in the navigation pane to expand the Configuration branch.

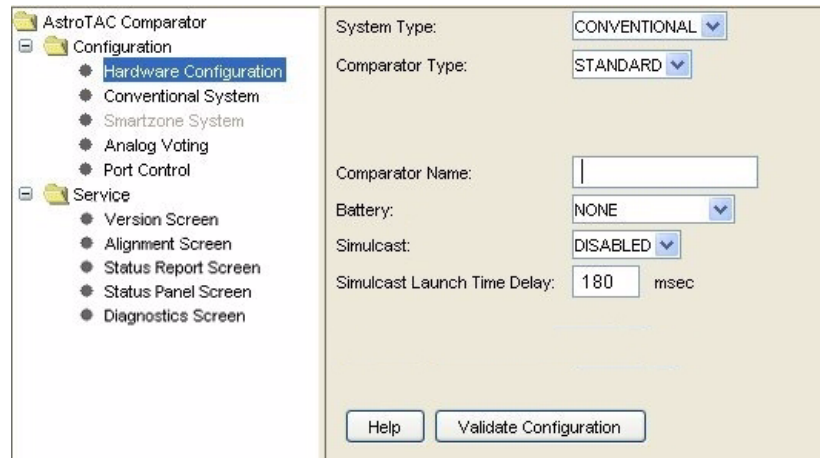


2. Click **Hardware Configuration** to display the comparator's retrieved configuration data as shown in the example above. You can now read the comparator's configuration data as programmed at the factory.
3. Review the comparator data shown to verify that it matches the equipment and the user's requirements. In most cases it matches, but there are circumstances where there may be discrepancies such as missing information on the original sales order, requiring the factory to leave certain fields at default values.
4. Change the data as required and when done save the configuration data to either:
  - An archive file as outlined in "Saving Configuration Data to an Archive File" on page 2-22, or
  - The comparator's codeplug as outlined in "Writing Codeplug Data to the Device" on page 2-20.



## Programming the Comparator

The RSS program allows the user to set up the operating parameters for an ASTRO-TAC comparator. Figure 4-1 shows the ASTRO-TAC comparator screens provided in the navigation pane that are discussed in this section.



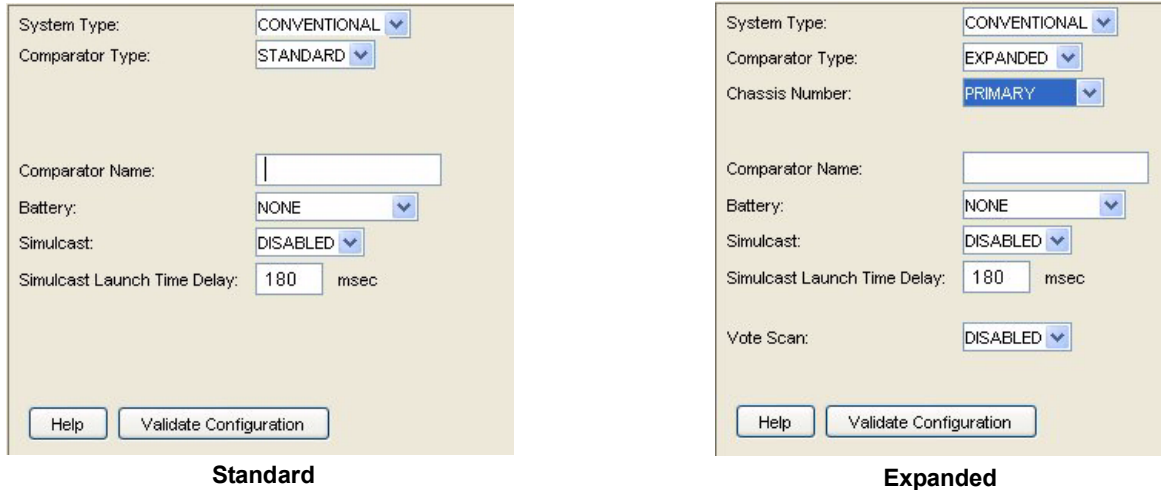
**Figure 4-1** Comparator Configuration Screen

Two ASTRO-TAC comparator systems are supported:

- The 3.6 version: This is a standard 16 port comparator.
- The 3.9 version: Supports both standard and expanded comparator configurations. The expanded comparator provides for a primary comparator with up to two ports for digital interface units (DIUs), and up to four expanded comparators, which support up to 64 ports for stations and receivers.

## Programming the Hardware Configuration Screen

Click **Hardware Configuration** in the navigation pane to access the Hardware Configuration screen (Figure 4-2). See Table 4-1 for the screen's data fields.



**Figure 4-2** Hardware Configuration Screen

**Table 4-1** Hardware Configuration Screen Data Fields

Data Field	Description	Range/Selections	Default	Recommended Setting (if any)
<b>Standard</b>				
System Type	This field provides for specifying the system in which the comparator is installed.	<ul style="list-style-type: none"> <li>Conventional</li> <li>Smartzone</li> </ul>	Conventional	System dependent
Comparator Name	This provides for identifying the comparator.	Up to 10 alpha-numeric characters	N/A	Customer defined
Battery	This specifies the battery type installed in the comparator.	<ul style="list-style-type: none"> <li>None</li> <li>LEAD_ACID_LIN</li> <li>LEAD_ACID_NON</li> <li>NICAD</li> </ul>	N/A	Must match the battery installed in the comparator
Simulcast	Specifies whether the comparator is installed in a simulcast system.	<ul style="list-style-type: none"> <li>Enabled</li> <li>Disabled</li> </ul>	Disabled	System dependent
Simulcast Launch Time Delay	Specifies the delay required for transmission in a simulcast system.	0 to 999 msec	180	System dependent
Vote Scan	Used by multicast channels. Enabling allows for the addition of a preamble to all TSBK control messages in the TSBK Preamble Duration Field.	<ul style="list-style-type: none"> <li>Enabled</li> <li>Disabled</li> </ul>	Disabled	System dependent
TSBK Preamble Duration	Accessible only when Vote Scan is enabled.	0 to 999 msec	0	System dependent
<b>Expanded</b>				
Comparator Type	This specifies the voting system that the comparator is installed in: standard or expanded.	<ul style="list-style-type: none"> <li>Standard</li> <li>Expanded</li> </ul>	Standard	System dependent
Chassis Number	This specifies the comparator's chassis number for a comparator installed in an expanded system.	<ul style="list-style-type: none"> <li>Primary</li> <li>Secondary1</li> <li>Secondary2</li> <li>Secondary3</li> <li>secondary4</li> </ul>	Primary	System dependent

## Programming the Conventional System Screen

Click **Conventional System** in the navigation pane to access the Conventional System screen (Figure 4-3). See Table 4-2 for the screen's data fields.

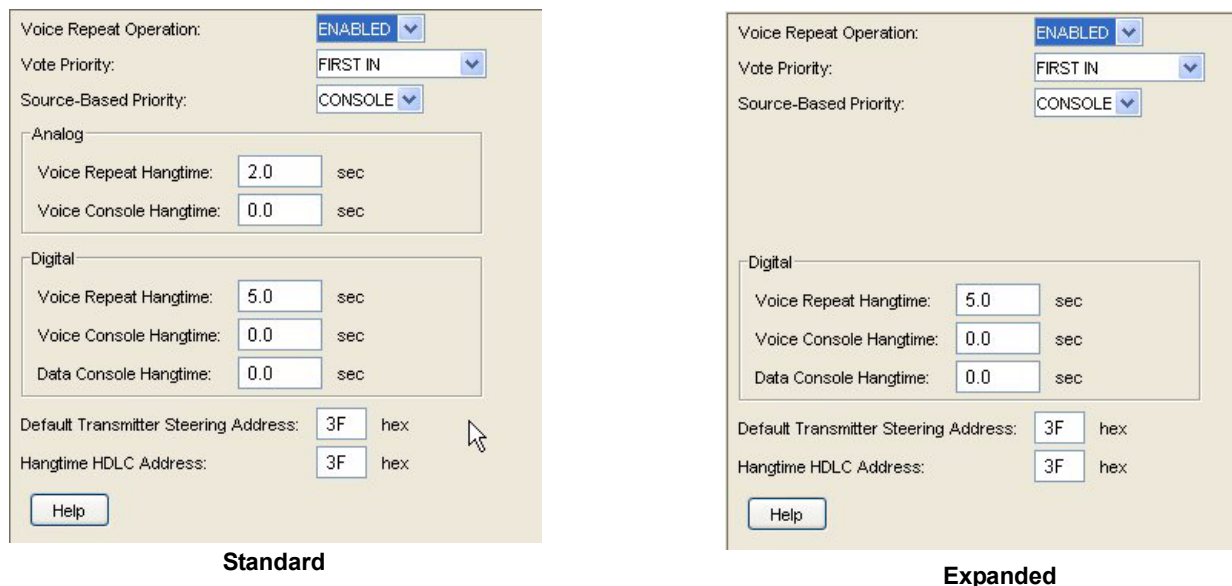


Figure 4-3 Conventional System Screen

Table 4-2 Conventional System Screen Data Fields

Data Field	Description	Range/Selections	Default	Recommended Setting (if any)
Voice Repeat Operation	Specifies whether voice repeat operation is used.	<ul style="list-style-type: none"> <li>Enabled</li> <li>Disabled</li> </ul>	Disabled	System dependent
Vote Priority	Specifies the high priority source.	<ul style="list-style-type: none"> <li>Analog&gt;Digital</li> <li>Digital&gt;Analog</li> <li>First In</li> </ul>	First In	System dependent
Digital Voice Repeat Hangtime	Specifies the length of time a station connected to a comparator remains keyed-up and transmitting silence at the conclusion of a digital voice call sourced by a subscriber unit.	0.0 to 15.0 seconds	5.0 seconds	System dependent
Digital Voice Console Hangtime	Specifies the amount of time a station connected to a comparator remains keyed-up and transmitting silence at the conclusion of a digital voice call sourced by a console.	0.0 to 15.0 seconds	0.0 seconds	System dependent
Digital Data Console Hangtime	Specifies the amount of time a station connected to a comparator remains keyed-up and transmitting silence at the conclusion of a digital data call sourced by a console (DIU port).	0.0 to 15.0 seconds	0.0 seconds	System dependent
Default Transmitter Steering Address	Specifies the address that the comparator uses when there is no unique address specified in the source message that the comparator is sending to stations.	00 to 3F (hex)	3F (hex)	System dependent
Hangtime HDLC Address	Specifies which station(s) transmits hangtime generated by the comparator.	00 to 3F (hex)	3F (hex)	System dependent

**Table 4-2** Conventional System Screen Data Fields (continued)

Data Field	Description	Range/Selections	Default	Recommended Setting (if any)
Analog Voice Repeat Hangtime	Specifies the amount of time a station connected to a comparator remains keyed-up and transmitting silence at the conclusion of an analog voice call sourced by a subscriber unit.	0.0 to 15.0 seconds	2.0 seconds	System dependent
Analog Voice Console Hangtime	Specifies the amount of time a station connected to a comparator remains keyed-up and transmitting silence at the conclusion of an analog voice call sourced by a console.	0.0 to 15.0 seconds	0.0 seconds	System dependent

**NOTE**

When data site steering is used in conventional systems, all stations must be configured for any Site Number from 2 to 62 but not 01.

## Programming the Smartzone System Screen

Click **Smartzone System** in the navigation pane to access the Smartzone System screen (Figure 4-4). See Table 4-3 for the screen's data fields.

**Figure 4-4** Smartzone System Screen**Table 4-3** Smartzone System Screen Data Fields

Data Field	Description	Range/Selections	Default	Recommended Setting (if any)
Failsoft Enable	This specifies whether the comparator operates in failsoft mode.	<ul style="list-style-type: none"> <li>Enabled</li> <li>Disabled</li> </ul>	Disabled	System dependent
Failsoft Mode	This specifies whether the comparator operates in digital or analog mode while in failsoft mode.	<ul style="list-style-type: none"> <li>Digital</li> <li>Analog</li> </ul>	Digital	System dependent
Channel Number	This specifies the channel number for the comparator.	<ul style="list-style-type: none"> <li>None</li> <li>1 through 28</li> </ul>	None	System dependent
Vote Priority	This specifies the high priority source.	<ul style="list-style-type: none"> <li>Analog&gt;Digital</li> <li>Digital&gt;Analog</li> <li>First In</li> </ul>	First In	System dependent

## Programming the Analog Voting Screen

Click **Analog Voting** in the navigation pane to access the Analog Voting screen (Figure 4-5). See Table 4-4 for the screen's data fields.

The screenshot shows the Analog Voting configuration screen with the following fields and values:

- Analog Voting Sample Period: 50 msec
- Analog First Vote Settle Time: 40 msec
- Analog Vote:
  - Vote And Hold Operation: DISABLED (dropdown menu)
  - First Vote Hold Time: 250 msec
  - Voting Hold Time: 250 msec
- Analog Signal Quality Debounce Time: 150 msec
- Analog Line Transient Settle: 20 msec
- Analog Voting Hysteresis: 1.1 dB

A Help button is located at the bottom left of the screen.

**Figure 4-5** Analog Voting Screen

**Table 4-4** Analog Voting Screen Data Fields

Data Field	Description	Range/Selections	Default	Recommended Setting (if any)
Analog Voting Sample Period	Provides for greater accuracy in determining the noise content of a signal by increasing the interval of time over which the analog signal quality is averaged.	5 to 10,000 msec	50 msec	System dependent
Analog First Vote Settle Time	Prevents infrastructure induced transients at the beginning of a call from degrading the initial voting decisions for each PTT.	5 to 10,000 msec	40 msec	System dependent
Vote and Hold Operation	Specifies the state of the analog vote and hold feature.	<ul style="list-style-type: none"> <li>• Enabled</li> <li>• Disabled</li> </ul>	Disabled	System dependent
First Vote Hold Time	Ensures that the voted port does not switch for a fixed amount of time after it is selected as the voted port for the first time.	5 to 10,000 msec	250 msec	System dependent
Voting Hold Time	Ensures that the voted port does not switch for a fixed amount of time after it is selected as the voted port.	5 to 10,000 msec	250 msec	System dependent
Analog Signal Quality Debounce Time	Specifies the amount of time a signal must be of higher quality than the current voted port before it is eligible to be routed as the voted port.	5 to 10,000 msec	150 msec	System dependent
Analog Line Transient Settle	Ensures that any transient on a port during the initial portion of an analog call is excluded from the signal quality measurement.	5 to 10,000 msec	20 msec	System dependent
Analog Voting Hysteresis	Ensures that ports with signals of imperceptible difference in noise content are not alternatively selected as the voted port.	0 to 12.0 dB	1.1 dB	System dependent

## Programming the Port Control Screen

Click **Port Control** in the navigation pane to access the Port Control screen (Figure 4-6). See Table 4-5 for the screen's data fields.

The screenshot shows the Port Control screen with the following fields and values:

- Port Number: 1 (PORT# 1 of 16)
- Port Type: STATION/RECEIVER (dropdown menu)
- Port Alias: NONE
- Link Type: V.24 LINK - EXTERNAL TRANSMIT CLOCK (dropdown menu)
- Digital Input Delay: 0 msec
- Data Site Steering Port: 1

Navigation buttons at the bottom include: Help, Previous Comparator, Previous Port, Next Port, and Next Comparator.

**Figure 4-6** Port Control Screen

**Table 4-5** Port Control Screen Data Fields

Data Field	Description	Range/Selections	Default	Recommended Setting (if any)
Port Number	This specifies the comparator port currently being configured.	1 through 16	1	System dependent
Port Type	This specifies to which device the port is connected.	<ul style="list-style-type: none"> <li>Disabled</li> <li>Station/Receiver</li> <li>DIU (conventional systems only)</li> <li>AEB (Smartzone systems only)</li> </ul>	Disabled	System dependent
Port Alias	This identifies the alias name that is assigned to the port.	Up to 10 alpha-numeric characters.	None	Customer determined
Link Type	This specifies what type of link connects the port and the device.	<ul style="list-style-type: none"> <li>Modem - 37 dBm</li> <li>Modem - 28 dBm</li> <li>V.24 Link - Internal Transmit Clock</li> <li>V.24 Link - External Transmit Clock</li> <li>Hybrid Link - Internal Transmit Clock</li> <li>Hybrid Link - External Transmit Clock</li> </ul>	V.24 Link - Internal Transmit Clock	System dependent

**Table 4-5** Port Control Screen Data Fields

Data Field	Description	Range/Selections	Default	Recommended Setting (if any)
Digital Input Delay	Specifies the amount of time required for a digital signal to travel from the station's wireline port to the comparator's input wireline port.	0 to 999 msec	0 msec	System dependent
DIU Rank	For a port connected to a DIU only; Specifies the rank among all connected DIUs that this port is given.	0 to 15	0	System dependent
Data Site Steering Port	Specifies the port number of the transmitting base stations that is closest to this port's receiver.	1 to 16	1	System dependent
<b>Modem Fields (conventional systems only)</b>				
Input Level Differential	Specifies the numerical difference between the port's modem or idle tone input signal level and the port's analog voice input signal level.	-20 to +3 dB	0 dB	System dependent
Analog Output Level	Specifies the output signal level used when transmitting an analog signal.	0 to -20 dBm	-14 dBm	System dependent
Modem Output Level	Specifies the signal level leaving the comparator on the port's 2-wire output when a modem link is either idle or supporting a digital call.	-20 to +3 dBm	-14 dBm	System dependent
Output Analog Link Timer	Specifies how often a link is transitioned to a digital state and a message is sent to verify that the link is functional and active.	10 to 300 sec	120 sec	System dependent
<b>Hybrid V.24 Link Fields (conventional and Smartzone systems)</b>				
Input Level Differential	Specifies the numerical difference between the port's modem or idle tone input signal level and the port's analog input signal level.	-20 to +3 dB	0 dB	System dependent
Analog Output Level	Specifies the output signal level used when transmitting an analog signal.	0 to -20 dBm	-14 dBm	System dependent
Idle Tone Output Level	Specifies the output level of the idle tone on the analog portion of the hybrid link when the analog side of the link is idle.	0 to -20 dBm	-10 dBm	System dependent

## Performing Comparator Alignment

Certain site-specific alignment tasks must be performed during optimization at the time they are installed and prior to being placed into service. The tasks required are shown below:

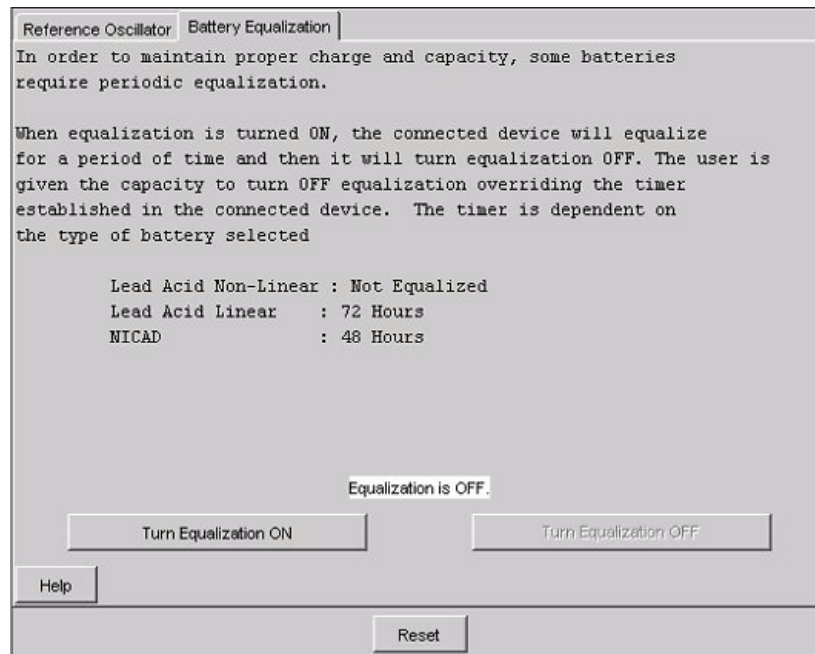
- "Equalizing Batteries" on page 4-10
- "Reference Oscillator Calibration Procedures" on page 4-10

## Equalizing Batteries

Sites equipped with storage batteries to provide comparator power in case of primary power failure require that the battery cells be equalized periodically. It is recommended that the batteries be equalized at the time of installation, and henceforth according to the schedule recommended by the battery manufacturer.

Battery equalization is a process under which the charging voltage to the batteries is slightly boosted for a period of time, typically 48 hours to 72 hours. This slight overcharging causes the individual cells to regenerate equally and provide nearly identical output voltages.

1. Click the **Battery Equalization** tab. The following Battery Equalization screen appears.



2. Click **Turn Equalization On** to start the process. The comparator power supply boosts the battery charging voltage slightly for a period of time determined by the type of batteries being used, as specified in the **Hardware Configuration** screen. A timer in the comparator controls the length of time that the boosted charging voltage is applied and automatically sets the charging voltage to its normal level when the timer expires.
3. If you must stop the process manually, click **Turn Equalization Off**.

## Reference Oscillator Calibration Procedures

The circuit device(s) that set the comparator's reference frequency exhibit slight variations in their operating characteristics over time. Approximately 90% of these variations occur in the first year, whether the comparator is in-service or in storage and non-operational. Therefore, it is necessary to calibrate the reference oscillator during optimization.



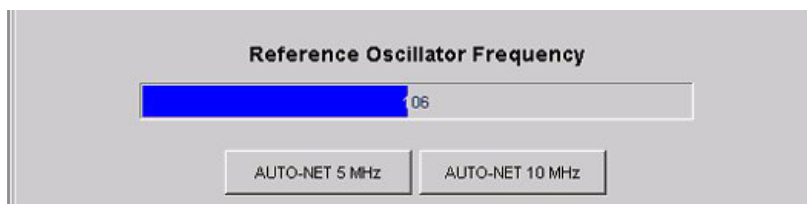
It is recommended that the frequency measurement equipment have an accuracy of 10 times greater than the accuracy required for the measurement. For example, if the frequency must be measured to be within  $\pm 5$  PPM, the accuracy of the measurement equipment should be  $\pm 0.5$  PPM.

The reference oscillator calibration procedure depends on the comparator configuration. There are two possible configurations. Perform the calibration procedure that corresponds to the comparator's specific configuration:

- Internal reference oscillator (located on the comparator control board) “Internal Reference Oscillator – Auto-Net Procedure” on page 4-11
- External source, typically 5 MHz: “External Reference Oscillator Calibration” on page 4-11

### Internal Reference Oscillator – Auto-Net Procedure

1. Connect the output of a stable 5 MHz or 10 MHz reference source to the BNC connector located at the bottom of the comparator control module front panel.
2. Set the frequency source for  $1.0 \pm 0.5$  V RMS output.
3. Click either **Auto-Net 5 MHz** or **Auto-Net 10 MHz**, depending on the reference in use, to begin the calibration process using the test reference source. The status area of the screen displays the progress.

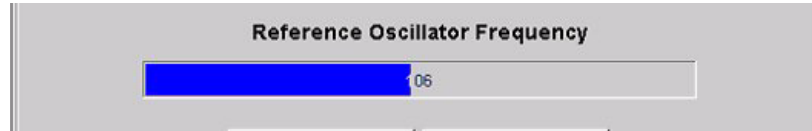


4. When the process is complete, close the Completed Successfully message window. The oscillator adjustment data is saved to the comparator codeplug and the comparator dequeys.

### External Reference Oscillator Calibration

This procedure is required only if the comparator reference oscillator does not lock. The accuracy of this procedure depends on the accuracy of the external source. Ensure that the 5 MHz or 10 MHz source provides the required accuracy, as defined in Table 1 in the Routine Maintenance section of the relevant functional manual for the comparator.

1. Connect the output of the stable 5 MHz or 10 MHz external reference source to either the BNC connector located at the bottom of the comparator control module front panel, or the BNC connector located on the comparator backplane.
2. Click either **Auto-Net 5 MHz** or **Auto-Net 10 MHz**, depending on the reference in use, to begin the calibration process using the test reference source. The status area of the screen displays the progress.



3. When the process is complete, close the Completed Successfully message window. The oscillator adjustment data is saved to the comparator's codeplug and a success message appears to the user.

## Diagnostics and Status

---

The RSS provides tools for troubleshooting and maintaining the station equipment. These include a status report log, a status panel display screen, diagnostic metering, and the ability to print a text version of the codeplug data to either a printer or a file.

- **Status Report Log:** The station reports status conditions resulting from operational or software malfunctions. Additionally, each of the diagnostics has associated with it a corresponding status. A status log, maintained in station memory, accumulates all status event data since the last station turns on. This status log may be retrieved, displayed, and used to aid in troubleshooting the station.
- **Status Panel Display:** The status panel display provides an “instrument panel” that displays station operating information and status messages. (The Status Panel menu also provides selections to display the current station software version).
- **Digital Metering:** The RSS allows access to critical metering points throughout the station circuitry and displays the current measurements. The readings may be compared with accepted ranges to aid in isolating a faulty module.
- **Print Codeplug Report:** A text version of the codeplug parameters and current settings may be printed to a printer connected to the RSS PC.
- **Save Codeplug Report:** A text version of the codeplug parameters and current settings may be printed to a file on the RSS PC hard disk.
- **Remote Station Disabling/Enabling:** This feature is typically used to disable (and subsequently enable) a station from a remote location through an RSS dial-up connection.

## Station/Comparator Status Messages

---

Status messages may be generated by any or all of the following sources:

- Diagnostics run at station power-up and/or at station reset may fail and generate status messages.
- Diagnostics run continuously during normal station operation.
- Status events log provides information about:
  - Internal abnormal operation provides information about the station itself.

- External abnormal operation provides information about the system in which the station is installed.

Status messages are time stamped and stored in the station memory in a status log file. Any subsequent status messages are appended to the file, resulting in an accumulation of status data. The RSS allows the status log file to be retrieved and displayed, providing useful diagnostics information to aid in troubleshooting the station. This section describes how to access, read, and interpret the status report data.

1. Connect the PC to the station as outlined in “Connecting the PC to the Device RSS Port” on page 2-11.
2. Launch the RSS program as outlined in “Launching the RSS Program” on page 2-12.
3. Read the station’s codeplug as outlined in “Reading the Device Codeplug” on page 2-14.
4. The Service screens provide access to the following status screens:
  - Metering Screens, see “Station Metering Screens” on page 5-2
  - Status Report Screen, see “Station/Comparator Status Report Screen” on page 5-3
  - Status Panel Screen, see “Station Status Panel Screen” on page 5-26
  - Version Screen, see “Station/Comparator Software Version” on page 5-30

## Station Metering Screens

The RSS allows you to access various critical metering points throughout the station circuitry and display the current measurements or status in the Metering Screen. The readings may be compared with accepted ranges to aid in troubleshooting. The Metering menu screen allows access to critical test points for the following station modules:

- Station Control / Wireline Interface Module
- Exciter Module
- Power Amplifier Module (QUANTAR only)
- Receiver Module
- Power Supply Module (QUANTAR only)
- Internal High Stability Oscillator

When you initially click Metering Screen in the navigation pane, “N/A” appears for all metering values for a few seconds until the data becomes valid. “N/A” appears for any metering point not applicable for the station after all valid values are displayed.

Click the appropriate tab to display the Metering screen for the desired module. A list of key metering points appears along with the acceptable value ranges for each metering point. See Figure 5-1 for an example.

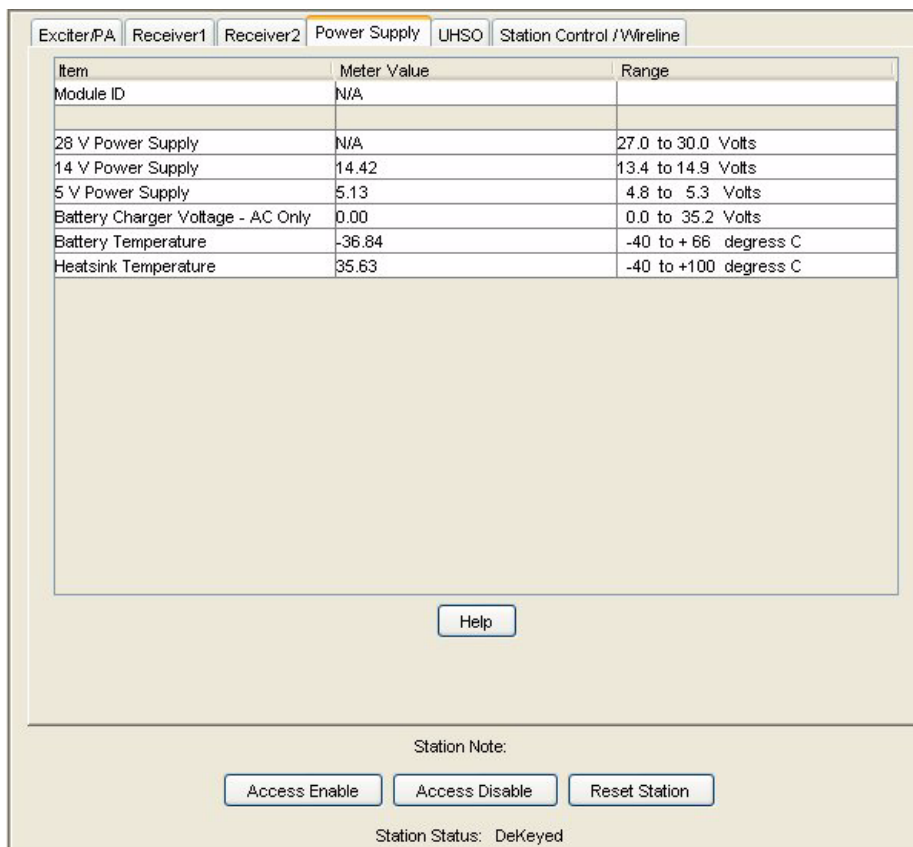


Figure 5-1 Station Metering Screen Example

## Station/Comparator Status Report Screen

The Status Report screen is comprised of a list of status messages, each with a date and time stamp indicating when the status message first occurred and last occurred (in relation to the last station power-up). The status list continues to grow, with previously unreported status messages added to the end of the list. The station stores up to 128 status messages in the log. Subsequent status messages overwrite the oldest status messages in the log on a first in/first out basis. If the number of messages exceed that which can be displayed, a scroll bar is provided on the right side of the screen. See Figure 5-2 and Figure 5-3 for examples.

The status screens provide information that can be used during troubleshooting along with performing the troubleshooting procedures located in the equipment service manual.

Software Download ID	00000A1E1E9E	Station Name	BOSTON_FIRE_#3
Device Date/Time	1900/01/01.02:15:21	Serial Number	448CAX0252
Station Control FW	R020.12.034	Station Wireline FW	R020.12.008
Station Exciter FW	R020.09.010	Codeplug Version	12

First Occurrence	Last Occurrence	Count	Message
1900/01/01.00:00:00	1900/01/01.00:00:00	1	SC ROOT 665 SYS_RESET 1
1900/01/01.00:00:07	1900/01/01.00:00:07	1	SC EXECUTE_STARTUP_DIAGS 156 DIAG_FAILED PS_BAT_CHR

Help      Clear All      Save Report      Refresh

Figure 5-2 Station Status Report Screen Example

Software Download ID	000002FC31B6	Serial Number	N/A
Device Date/Time	2005/12/06 10:36:05	AstroTAC Wireline FW	VL_R03.07.003
AstroTAC Control FW	OC_R03.07.005	Codeplug Version	3.9

First Occurrence	Last Occurrence	Count	Message
1995/08/19.20:41:53	1995/08/19.20:41:53	1	AC1 Fatal Internal Software Error #044 2
1995/08/19.20:41:53	1995/10/28.18:01:35	9	AC1 System Reset. 0
1995/08/19.20:42:07	1995/10/28.18:01:49	9	AC1 Comparator Heartbeat function enabled 2
1995/08/19.20:42:07	1995/10/28.18:01:49	6	PORT 01 W/L1 Link Initializing:Box Reset 7
1995/08/19.20:42:22	1995/10/28.18:02:04	6	PORT 01 W/L1 Link Failure 7
1995/08/19.20:50:36	1995/08/19.20:50:36	1	AC1 Fatal Internal Software Error #018 2
1995/08/19.20:50:47	1995/08/19.20:50:47	1	AC1 No wirelines present in comparator. 1
1995/08/19.20:50:47	1995/08/19.20:50:47	1	AC1 W/L 1 missing - 1 or more ports enabled 1
1995/08/20.14:56:36	1995/10/28.18:01:35	5	AC1 Reset ordered by RSS 40
1995/08/20.14:56:51	1995/08/20.15:04:41	2	PORT RS AC1 Link Initializing:Box Reset 39
1995/08/20.14:57:06	1995/08/20.15:04:56	2	PORT RS AC1 Link Failure 39
1995/08/20.15:34:04	1995/08/21.20:35:23	2	AC1 W/L 1 present - All ports disabled 1
1995/08/21.20:35:12	1995/08/21.20:35:12	1	AC1 Fatal Internal Software Error #046 49
1995/08/21.20:53:36	1995/08/21.20:53:36	1	AC1 Fan state set to AUTO via RSS 1
1995/10/07.00:15:46	1995/10/07.00:16:01	2	PORT 01 W/L1 Link Initializing Cleared 7
1995/10/07.00:15:46	1995/10/07.00:15:46	1	PORT 01 W/L1 Link Failure Cleared 7
1995/10/07.00:15:47	1995/10/07.00:15:47	1	AC1 Fatal Internal Software Error #044 2
1995/10/22.23:58:54	1995/10/22.23:58:54	1	PORT 01 W/L1 Link Initializing:CD Timeout 7
1995/10/22.23:58:54	1995/10/22.23:58:54	1	PORT 01 W/L1 Illegal CD Transition 5
1995/10/28.18:05:22	2005/12/06.10:36:04	2	AC1 OS date reset via RSS 40
2005/12/06.18:05:23	2005/12/06.10:36:04	2	AC1 OS time reset via RSS 40

Help
Clear All
Save Report
Save Alerts
Refresh

Figure 5-3 Comparator Status Report Screen Example

### Station/Comparator-Generated Status Messages

Table 5-1 lists status messages generated within the station/comparator. Many of the station/comparator-generated status messages do not indicate that service is required. They merely indicate that an event has occurred. These events provide the technician with status information that can be useful in debugging other issues should they arise. These status messages may be grouped into three categories:

- Internal System Status Messages
- Status messages resulting from incorrect RSS programming
- Hardware-Generated Status Messages

Recommendations for interpreting and responding to these status messages are provided below and in Table 5-1.

- **Internal System Status Messages:** These messages are reported by the station and provide a highly detailed account of the internal operation of the station. Status messages of this type are often associated with the data in internal registers, data communications between ICs on the station circuit boards, and various other software processes. These status messages may result from such occurrences as a power glitch/failure, lightning strike, or phone line malfunctions, any of which are capable of corrupting internal station data. Due to the precision of the ASTRO signaling protocol, minor errors in signaling protocol may result in status messages (even though these may not be service-affecting).
- **Incorrect RSS Programming:** Status messages in this category usually result from incorrect or invalid codeplug programming.
- **Hardware-Generated Status Messages:** Status messages of this type are the result of a station or external hardware malfunction.

**Table 5-1** Station / Comparator-Generated Status Messages

Station-Generated Status Message	Source		
	Internal System Status	Incorrectly Programmed RSS	Hardware Failure
ABORT SEQUENC	✓		
abort streaming	✓		
ACCESS_DISABLE_ABORT_V52	✓		Exciter, Power Amp, UHSO, 5 MHz External Ref, 1PPS GPS, Battery Revert Mode, Loss of 16.8 MHz
ACCESS_TO_PRES_MEM_FAILED	✓		
A_D ERROR	✓		
ALREADY DISABLED	✓		
ANALOG_LINK_FAIL_ACTIVE	✓		
ANALOG_LINK_FAIL_INACTIVE	✓		
ANT_RLY_SHORT_ALARM			Power Amplifier Antenna Relay
ASTRO_FRAME_OVERWRITE	✓		
ASTRO_TEST_TONE_ABORTED	✓		
BAD BD LENGTH	✓		
BAD_ERROR_LOG_ENTRY	✓		
BAD_EXT_WATTMETER_TYPE	✓		
BAD_HC11_OPCODE	✓		
BAD_INT_WATTMETER_TYPE	✓		



**Table 5-1** Station / Comparator-Generated Status Messages (continued)

Station-Generated Status Message	Source		
	Internal System Status	Incorrectly Programmed RSS	Hardware Failure
BAD_NVM_MCS_READ	✓		
BAD_NVM_MCS_WRITE	✓		
BAD_PENDULUM_COMMAND	✓		
BAD_PRES_MEM_SIZE	✓		
BAD_V.24_CONNECTION	✓		
Base station alarm send failed	✓		
BATTERY_TEMP_PROBE_ALARM			Battery Temp Probe Not Present
BATT_REVERT_ALARM	✓		
BTRY OVR ALARM	✓		
buffer is empty Isr was called	✓		
buffer is not last in frame but SCCE is RXF	✓		
CALLSIGN_INVALID		Verify Call Sign entered on Channel Information Screen	
Cannot allocate buffer	✓		
CANNOT_GET_APP	✓		
CANNOT_GET_BOOT2	✓		
CANNOT_LOCK_EXT_REF			External Ref Not Present
CD_LOST_TIMER_EXPIRED	✓		
CD_LOST_WITH_ANA_START	✓		
CD_LOST_WITHOUT_ANA_START	✓		
CIRC_TEMP_ALARM	✓		Circulator
CIRCULAR_QUEUE_CLUSTERS		Check system programming	
CONSOLE REQUEST INDV ID <xxxx> SAME AS RADIO ID	✓		
COULD_NOT_OPEN_FILE	✓		
CP_TIMEOUT	✓		
CP_TO_OLD_FOR_17_TRCS	✓		
CRC ERRO	✓		

**Table 5-1** Station / Comparator-Generated Status Messages (continued)

Station-Generated Status Message	Source		
	Internal System Status	Incorrectly Programmed RSS	Hardware Failure
CRC_LINK_DEGRADATION	✓		
CROSSLOAD_CODEPLUG_ERROR	✓		
CTS_ASSERTED	✓		
CTS or CD were lost on loopback	✓		
CTS_REMOVED	✓		
CU one minute update	✓		
CURR ACK SEMA V FAILED	✓		
CURRENT ACK SEMAP4 CREATE FAILED	✓		
CURRENTLY ACK P FAILED	✓		
CURRENTLY ACK V FAILED	✓		
DAMQ_FLUSH	✓		
Data block timeout	✓		
DATA_READY_ALREADY	✓		
DATA_READY_TIMED_OUT	✓		
DATA_UNDERRUN	✓		
dbs_bs_abort_tx failed	✓		
dbs_bs_change_busy failed	✓		
dbs_bs_config failed	✓		
dbs_bs_console_read () failed	✓		
dbs_bs_console_write () failed	✓		
dbs_bs_read_eeprom () failed	✓		
dbs_bs_send_mid failed	✓		
dbs_bs_set_st_id failed	✓		
dbs_bs_write_eeprom () failed	✓		
DBS_NVM_PTTN_ERROR			Station Control
Debug Queue create failed	✓		
Debug Task creation failed	✓		
Debug Task start failed	✓		
Default in switch	✓		

**Table 5-1** Station / Comparator-Generated Status Messages (continued)

Station-Generated Status Message	Source		
	Internal System Status	Incorrectly Programmed RSS	Hardware Failure
DETECTED_MODEM_RESET	✓		
DETERMINE_STATION_MODE	✓		
DIAG_TEST_RESULT_MISMATCH	✓		
DIU_ACK_MSG_NOT_MATCH	✓		
DIU_NACK_MSG_NOT_MATCH	✓		
DIU_3_NOACKS	✓		
DL_CMD_QUEUE_CREATE_FAILED	✓		
DLM_OPERATING_PROPERLY	✓		
DOB_TIMEOUT	✓		
DPL_INACTIVE_WHEN_PL_ACTV	✓		
DPLL_ERROR	✓		
DRIVER_OVERDRIVE_ALARM			Exciter Power Amplifier
DSP_TIMEOUT	✓		
DSTN_FILE_WRITE_ERROR	✓		
E_A_D_RETURN	✓		
E_BAD_NVM_WC_WRITE			Station Control
E_BAD_OPCODE	✓		
E_CREATE_STREAM_SOCKET	✓		
EEPROM_CHKSUM_ALARM			Exciter
E_ERASE_FLASH	✓		
E_FRAME_INDEX_OUT_OF_SYNC	✓		
E_ILLEGAL_PORT_NUMBER	✓		
END_QSEND_FAILED	✓		
ENTERING_FLASH_MODE	✓		
ENTERING_NORMAL__MODE	✓		
E_PARAMETER_RANGE	✓		
E_PEND_OUT_OF_BOUNDS_ADJ	✓		
ERASE_FLASH_REQ	✓		
E_RECEIVE_SOCKET_DATA	✓		

**Table 5-1** Station / Comparator-Generated Status Messages (continued)

Station-Generated Status Message	Source		
	Internal System Status	Incorrectly Programmed RSS	Hardware Failure
ERROR_IN_COPY_FILE	✓		
ERROR_IN_PERFORM_DECOMP	✓		
ERROR_IN_PROC_APP_HEADER	✓		
Error out of range	✓		
E_STN_NOT_ACCESS_DISABLED	✓		
E_SWITCH_SCS_RESET_REQ	✓		
E_TIME_DATE_SET	✓		
E_UHSO_OUT_OF_BOUNDS_ADJ	✓		
event received no message in Queue	✓		
E_WC_SCAN_CMD_TYPE	✓		
EXCEPTION			Station Control
EXCITER ALARM	✓		Exciter Power Amplifier
EXCITER_SPIF_TIMEOUT	✓		
EXT_CIRC_TEMP_ALARM (High Power <i>QUANTAR</i> Only)			Extrnl. Circ.
EXT_WM_FWD_PWR_ALARM ( <i>Quantro</i> Only)			Exciter Power Amplifier
EXT_WM_REFL_PWR_ALARM ( <i>Quantro</i> Only)			Exciter Power Amplifier
EXT_WM_VSWR_ALARM ( <i>Quantro</i> Only)			Exciter Power Amplifier
FAILSOFT			Trunking Failure
FAN_FAILURE_ALARM			Cooling Fan(s)
FINISH_NVM_CONDITIONING	✓		
First block in the middle of another frame	✓		
FORCE_MODEM_HARD_RESET	✓		
FORCE_MODEM_LONG_TRAIN	✓		
FORCE_MODEM_SOFT_RESET	✓		
Frame abort received	✓		
frame_abort sending failed	✓		

**Table 5-1** Station / Comparator-Generated Status Messages (continued)

Station-Generated Status Message	Source		
	Internal System Status	Incorrectly Programmed RSS	Hardware Failure
FRAME_LENGTH VIOLATION	✓		
FRAMES_RCVD_DURING_IDLE	✓		
FREQUENT_RESET	✓	Check status log for cause of reset	
FRMR ARRIVED WITH:	✓		
FWD PWR ALARM	✓		
GENERIC_ALARM_1 thru 5	✓		
GET_CP_TIMESTAMP	✓		
GCU start task failed	✓		
GCU task create failed	✓		
gmm task creation failed	✓		
gmm task start failed	✓		
GSM start task failed	✓		
GSM task create failed	✓		
HC11_BAD_LENGTH	✓		
HC11_COMM_OK	✓		
HC11_MSG_RETRIES_FAILED	✓		
HC11_NOSPIF	✓		
HC11_NO_RESP	✓		
HC11_PORT_ACCESS_FAILURE	✓		
hcl task create failed	✓		
hcl task start failed	✓		
hct task create failed	✓		
hct task start failed	✓		
HDLC FRAME ABORTED on Receive	✓		
HDLC_FRAMES_QUEUE_CREATE_FAILED	✓		
hdlc in partn creation failed	✓		
hdlc out partn creation failed	✓		
HDLC PENDING QUEUE CREATE FAILED	✓		
HDLC_TASK_UNINITIALIZED	✓		

**Table 5-1** Station / Comparator-Generated Status Messages (continued)

Station-Generated Status Message	Source		
	Internal System Status	Incorrectly Programmed RSS	Hardware Failure
HDLC TX QUEUE CREATE FAILED	✓		
HDLC_TX_OVERRUN_ERROR	✓		
HDLC WINDOW_FULL	✓		
hcl task create failed	✓		
hcl task start failed	✓		
HDL WAKEAFTER_FAILED	✓		
hdr task create failed	✓		
hdr task start failed	✓		
hdt task create failed	✓		
hdt task start failed	✓		
HIGH_POWER_RAIL			Power Supply Exciter Power Amplifier
HIGH_FINAL_PA_VSWR_ALARM			Power Amplifier
HIGH_PA_TEMP_ALARM			Power Amplifier
HIGH_TX_FINAL_VSWR_ALARM			Exciter Power Amplifier
HOLD QUEUE CREATE FAILED	✓		
HOST_TO_TX_CHKSUM_ERR	✓		
hpl task create failed	✓		
hpl task start failed	✓		
hpt task create failed	✓		
hpt task start failed	✓		
HPT_TASK_UNINITIALIZED	✓		
Idles Illegal Option	✓		
I Frame should not arrive so far..	✓		
ILLEGAL_RX_SPACING	✓		
ILLEGAL_TX_EEPROM_ADDRESS	✓		
INCOMPAT_CODEPLUG	✓	Upgrade and download latest version codeplug	

**Table 5-1** Station / Comparator-Generated Status Messages (continued)

Station-Generated Status Message	Source		
	Internal System Status	Incorrectly Programmed RSS	Hardware Failure
INDV ID <xxxx> GRP <xxxx>: EMERGENCY RQST DOWNGRADE		Misprogrammed subscriber radio	
INDV ID <xxxx> GRP <xxxx> FROM CNSL: MULTIGRP RQST ON TALKGRP		Misprogrammed subscriber radio	
INDV ID <xxxx> GRP <xxxx> FROM CNSL: NOT EMERGENCY CAPABLE		Misprogrammed subscriber radio	
INDV ID <xxxx> GRP <xxxx> FROM CNSL: TALKGRP RQST ON MULTIGRP		Misprogrammed subscriber radio	
INDV ID <xxxx> GRP <xxxx> FROM RADIO: MULTIGRP RQST ON TALKGRP		Misprogrammed subscriber radio	
INDV ID <xxxx> GRP <xxxx> FROM RADIO: TALKGRP RQST ON MULTIGRP		Misprogrammed subscriber radio	
INDV ID <xxxx> GRP <xxxx> FROM WRLN: MULTIGRP RQST ON TALKGRP		Misprogrammed subscriber radio	
INDV ID <xxxx> GRP <xxxx> FROM WRLN: TALKGRP RQST ON MULTIGRP		Misprogrammed subscriber radio	
INDV ID <xxxx> GRP ID <xxxx>: INVALID GRP RECEIVED FROM CNSL		Misprogrammed subscriber radio	
INDV ID <xxxx> GRP ID <xxxx>: INVALID GRP RECEIVED FROM RADIO		Misprogrammed subscriber radio	
INDV ID <xxxx> MULTIGRP <xxxx>: TLKGRP-MULTIGRP MISMATCH		Misprogrammed subscriber radio	
INDV ID <xxxx>: SAC RECORD NOT AVAILABLE		Check system programming	
INIT_ACCESS_CTRL_PORTS	✓		
INIT_FROM_BAD_LM_SW_STATE	✓		
INIT_FROM_BAD_RR_SW_STATE	✓		
INIT_FROM_LOSS_OF_CD	✓		
INIT_FROM_MAX_INBND_TIMER	✓		
INIT_FROM_MODEM_DIAG_FAIL	✓		
INIT_FROM_RESET	✓		
INIT_FROM_RR_ACT_TIMER	✓		
INIT_FROM_TOO_MANY_SABMS	✓		
INIT_FROM_USER_ENABLE	✓		

**Table 5-1** Station / Comparator-Generated Status Messages (continued)

Station-Generated Status Message	Source		
	Internal System Status	Incorrectly Programmed RSS	Hardware Failure
INIT_FROM_V24_CD_LOSS	✓		
INIT_FROM_V52_FAILURE	✓		
INIT_FROM_XID_MGMT	✓		
INITIALIZATION_FAILURE	✓		
INITIALIZE_FLED	✓		
INITIALIZE_FP	✓		
INITIALIZE_GPS	✓		
INITIAL_SEARCH_GPS_FAILURE			No 1 pps GPS input to station
INITIAL_SYNC_1PPS_FAILURE			No 1 pps GPS input to station
INIT_ISV_CROSSLOAD_CLIENT	✓		
INIT_SCST	✓		
INT_WM_FWD_PWR_ALARM		Re-align power out	Wireline Exciter Power Amplifier
INT_WM_REFL_PWR_ALARM		Re-align power out	Wireline Exciter Power Amplifier
INT_WM_VSWR_ALARM		Re-align power out	Exciter Power Amplifier
INVALID_CMD_IN_FILE	✓		
INVALID_CODEPLUG	✓	Upgrade and download latest version codeplug	
INVALID_COMMAND_MESSAGE	✓		
INVALID_CPLUG_CHECKSUM	✓		
INVALID DUAL WORD ISW	✓		
INVALID_FREQ_BAND	✓	Verify frequency entered on Hardware Configuration Screen	
Invalid GIB opcode	✓		
INVALID GROUP ID <xxx> RECEIVED FROM MANAGER		Misprogrammed system or subscriber radio	



**Table 5-1** Station / Comparator-Generated Status Messages (continued)

Station-Generated Status Message	Source		
	Internal System Status	Incorrectly Programmed RSS	Hardware Failure
INVALID INDV ID <xxx> RECEIVED FROM CONSOLE		Misprogrammed system or subscriber radio	
INVALID INDV ID <xxx> RECEIVED FROM MANAGER		Misprogrammed system or subscriber radio	
INVALID INDV ID <xxx> RECEIVED FROM RADIO		Misprogrammed system or subscriber radio	
INVALID_LAUNCH_TIME	✓		
INVALID_MCS_TABLE_ENTRY	✓		
INVALID_METERING_VALUE	✓		
INVALID_PL_DPL_DETECT	✓		
INVALID_SCC	✓		
INVALID SINGLE WORD ISW	✓		
INVALID_SPI_MSG_LENGTH	✓		
INVALID_SPI_OPCODE	✓		
INVALID_TX_DATA_READY_CODE	✓		
INVALID_WC_STATE		Out of Date RSS	
INVALID_WIRELINE_BOARD			Wireline
ISV_CLIENT	✓		
Last block arrived but frame_buf_ptr ==NULL	✓		
last_buf sending failed	✓		
LAUNCH_TIME_OVERRIDE	✓		
LINK_FAILURE_ACTIVE	✓		
LINK_FAILURE_INACTIVE	✓		
LINK_HWR_INIT	✓		
LINK_HWR_INIT_COMPLETE	✓		
LINK_INIT_ACTIVE	✓		
LINK_INIT_INACTIVE	✓		
LINK MNG QUEUE CREATE FAILED	✓		
LINK STILL DOWN	✓		

**Table 5-1** Station / Comparator-Generated Status Messages (continued)

Station-Generated Status Message	Source		
	Internal System Status	Incorrectly Programmed RSS	Hardware Failure
LOCAL_LINK_HWR_FAILURE			Wireline <i>ASTRO</i> Modem
LOCAL_LINK_HWR_OK	✓		
LOG_TX_INHIBIT_FROM_WL	✓		
LOST_CD_WHILE_OP_PROP	✓		
LOW_POWER_RAIL			Power Supply Exciter Power Amplifier
LT_SEND_FAILURE			Wireline <i>ASTRO</i> Modem
LT_SEND_OK	✓		
malloc () failed	✓		
MAX_INBND_ANA_TMR_EXP_L1	✓		
MCS_MAX_CALLS	✓		
MCS_MAX_TIME	✓		
MCS_NVM_PTTN_ERROR			Station Control
Middle block arrived but frame_buf_ptr ==NULL	✓		
MI_NVM_PTTN_ERROR			Station Control
MISSED_ANA_STOP_ON_TX_WL	✓		
Modem/Cable	✓		
MODEM_COMMAND_FAILURE			Wireline <i>ASTRO</i> Modem
MODEM_FAILURE_ACTIVE			Wireline <i>ASTRO</i> Modem
MODEM_FAILURE_INACTIVE	✓		
MODEM_FAST_TRAINED	✓		
MODEM_LONG_TRAINED	✓		
MODEM_TRAINED_ON_DATA	✓		
Monitor partition create failed	✓		
Monitor Queue Create failed	✓		
morse_complete sending failed	✓		
Morse id timedout	✓		

**Table 5-1** Station / Comparator-Generated Status Messages (continued)

Station-Generated Status Message	Source		
	Internal System Status	Incorrectly Programmed RSS	Hardware Failure
MTRING_STRT_STOP_MISMATCH	✓		
NACK_ERROR	✓		
NEGATIVE_BLOCK_COUNT	✓		
NEW_CODEPLUG_RECV	✓		
NO_BUFFERS	✓		
NO_CMD_FOUND			Corrupt RSS installation, corrupt upgrade installation
NO_LAST_TX_BUFFER	✓		
NO_EXCITER_PA_MATCH		Verify Programming	
NO_FORWARD_PWR			Exciter Power Amplifier
Non frame on frame Queue	✓		
non HH_L1_L2_CTYPE arrived	✓		
NON OCTET	✓		
Non-preempt mode failed	✓		
NO_PA_DETECTED		Verify Programming	Power Amplifier
NO RX BD!!! OVERRUN	✓		
Not RDLAP_19200	✓		
NOT_ENOUGH_MEMORY	✓		
null partition id	✓		
Null value variable	✓		
NVM_CONDITIONING_ERROR			Station Control
ODR_CAL_CIRC_TEMP_ALRM			Exciter Power Amplifier
ODR_CAL_PA_FAIL_ACTIVE			Exciter Power Amplifier
ODR_CAL_FINL_PA_VSWR_ALRM			Exciter Power Amplifier
ODR_CAL_NO_FWD_PWR_ALRM			Exciter Power Amplifier

**Table 5-1** Station / Comparator-Generated Status Messages (continued)

Station-Generated Status Message	Source		
	Internal System Status	Incorrectly Programmed RSS	Hardware Failure
ODR_CAL_NOT_KEYED_2_SECS			Exciter Power Amplifier
ODR_CAL_OPN_PWR_LOOP_ALRM			Exciter Power Amplifier
ODR_CAL_PA_FAN_ALRM			Exciter Power Amplifier
ODR_CAL_PA_LO_SUPPLY_ALRM			Power Supply Exciter Power Amplifier
ODR_CAL_PA_TEMP_ALRM			Exciter Power Amplifier
ODR_CAL_POWER_LEVEL_ALARM			Exciter Power Amplifier
ODR_CAL_TX_FINL_VSWR_ALRM			Exciter Power Amplifier
ODR_CAL_TX_HOLDOFF_ACTIVE			Exciter Power Amplifier
ODR_CAL_TX_INHIBIT_ACTIVE			Exciter Power Amplifier
ODR_CAL_TX_LOCK_ALRM			Exciter Power Amplifier
ODR_CAL_TX_LOCK_INACTIVE			Exciter Power Amplifier
ODR_CAL_UNABLE_START			Exciter Power Amplifier
old event detected	✓		
OPEN_POWER_LOOP_ALARM			Exciter Power Amplifier
Outbound MDC message arrived	✓		
Outbound msg received	✓		
OUT_OF_BUFFERS	✓		
OVERRUN ERROR	✓		
OVERVOLTAGE_ALARM			Power Supply Exciter Power Amplifier

**Table 5-1** Station / Comparator-Generated Status Messages (continued)

Station-Generated Status Message	Source		
	Internal System Status	Incorrectly Programmed RSS	Hardware Failure
P1_FIVE_OR_TEN_MHZ_LOST		Perform auto-netting procedure in Chapter 4	Station Control 5 MHz External Reference
P1_PENDULUM_LOST			Station Control
PA ALARM			Power Supply Exciter Power Amplifier
PA_LOW_SUPPLY_ALARM			Power Supply Power Amplifier
PA_ON_ALARM	✓		
PEND RECEIVE FAILED	✓		
PHYSICAL TX ERROR	✓		
PIB ALARM	✓		PIB Board
PL_INACTIVE_WHEN_DPL_ACTV	✓		
PORT_ACCESS_FAILURE	✓		
PP_NVM_PTTN_ERROR			Station Control
Preempt mode failed	✓		
PRIORITY_REQUEST_FAILURE	✓		
PROCESS_MOVE_CMD	✓		
PROC_HEADER_BYTE_ERR	✓		
Psos error	✓		
Psos Event After failed	✓		
Psos event receive failed	✓		
Psos EventSend failed	✓		
Psos get buff failed	✓		
Psos no event	✓		
Psos PPartition create failed	✓		
Psos Receive failed	✓		
Psos RetBuf fail	✓		
Psos Send failed	✓		
Psos TaskDelete failed	✓		

**Table 5-1** Station / Comparator-Generated Status Messages (continued)

Station-Generated Status Message	Source		
	Internal System Status	Incorrectly Programmed RSS	Hardware Failure
Psos TaskResume failed	✓		
Psos task wake after failed	✓		
Psos Timer Cancel failed	✓		
PWR SPLY ALARM	✓		Power Supply Exciter Power Amplifier
Q_RECEIVE_TIMED_OUT	✓		
QUEUE_AND_COUNT_MISMATCH	✓		
Queue create failed	✓		
RADIO REQUEST INDV ID <xxxx> SAME AS CONSOLE ID		Misprogrammed system or subscriber radio	
RAW RX QUEUE CREATE FAILED	✓		
rawrxq create failed	✓		
RCVD_BAD_ADDR_FRAME	✓		
RCVR_FAILED			Receiver
RCVR_NOT_COMP		Verify Programming	Receiver
READ_BYTE_COUNT_FAILURE	✓		
READ_IP_HDLC_ERROR	✓		
READY_TO_SIMULCAST	✓		
RECEVIE_FNAME_ERR	✓		
RECV_SOCKET_DATA_ERR	✓		
REFL PWR ALARM			
REGAINED_CD_WHILE_OP_PROP	✓		
REL DATA WHILE GOING DOWN	✓		
remote out q creation failed	✓		
remote partiton create failed	✓		
RE_SEARCH_GPS_FAILURE			No 1 pps GPS input to station
RESET	✓		
RESET_DLM_STATE_VARIABLES	✓		

**Table 5-1** Station / Comparator-Generated Status Messages (continued)

Station-Generated Status Message	Source		
	Internal System Status	Incorrectly Programmed RSS	Hardware Failure
RESET_FROM_ADDR_ERROR	✓		
RESET_FROM_BUS_ERROR	✓		
RESET_FROM_UNINIT_VECTOR	✓		
Restart by MDC command	✓		
RE_SYNC_1PPS_FAILURE			No 1 pps GPS input to station
RETRIEVED_OLD_CLST_STATIC	✓		
RETRIEVED_OLD_LAUNCH_TIME	✓		
RETRY_REQUIRED	✓		
RF key down	✓		
ridleg creation failed	✓		
Rid task creation failed	✓		
Rid task start failed	✓		
ring creation failed	✓		
Rin task creation failed	✓		
Rin task start failed	✓		
rmm_control queue create failed	✓		
ROUTINE_INIT_FAILED	✓		
routq creation failed	✓		
rout task creation failed	✓		
rout task start failed	✓		
RSS_TEST_TONE_OVERRIDE	✓		
RTS_ASSERTED	✓		
RTS_REMOVED	✓		
RX2_LOCK_FAIL		Incorrectly programmed receive frequency on Channel Information Screen	Receiver
rxbdq create failed	✓		
RXB_EVENT_DETECTED	✓		
rx_block sending failed	✓		

**Table 5-1** Station / Comparator-Generated Status Messages (continued)

Station-Generated Status Message	Source		
	Internal System Status	Incorrectly Programmed RSS	Hardware Failure
RX_LOCK_FAIL		Incorrectly programmed receive frequency on Channel Information Screen	Receiver
Rx off but msg received	✓		
RX_SNET_SYNC_ERROR	✓		Receiver
rx_station_id sending failed	✓		
SAM ALARM	✓		SAM Board
SAM_NOT_RESPONDING			SAM Board
SA_NVM_PTTN_ERROR			Station Control
SCAN_RX_ACT_INCOMPATIBLE		Verify RSS Programming	
SCAN_ZERO_FREQS_INCOMPAT		Verify RSS Programming	
scc rx part create failed	✓		
scc tx part create failed	✓		
SC_NVM_PTTN_ERROR			Station Control
SC_REQUESTED_RETRANSMIT	✓		
SCS_COMMAND	✓		
SDMA_BUS_ERROR	✓		
SECURENET_BUFFER_ERROR	✓		
send DSP block failed	✓		
SHTERM_BACK_TO_BACK	✓		
SHTERM_NO_TRK_LC	✓		
SHTERM_RCVD_DURING_IDLE	✓		
SITE_CONTROL_ERROR	✓		
SOURCE_FILE_READ_ERROR	✓		
SPI_BUFFER_FULL	✓		
SPI_NOSPIF	✓		
SPI_TIMEOUT	✓		
SR_NVM_PTTN_ERROR			Station Control



**Table 5-1** Station / Comparator-Generated Status Messages (continued)

Station-Generated Status Message	Source		
	Internal System Status	Incorrectly Programmed RSS	Hardware Failure
STARTED_ANALOG_RX_WL_CALL	✓		
STARTED_ANALOG_TX_WL_CALL	✓		
START_NVM_CONDITIONING	✓		
STATION_CTRL_FAN_FAIL			Station Control cooling fan on backplane failed
STATION NOT DEKEYED	✓		
STATION_PORTNAME_CLST	✓		
STATION_RCVD_SABM	✓		
STATION_RCVD_UA	✓		
STATION_SENT_SABM	✓		
STATION_SENT_UA	✓		
STN_RCVD_ANALOG_START_ICW	✓		
STN_RECVD_ANALOG_STOP_ICW	✓		
STN_RECVD_STAND_ALONE_ICW	✓		
STN_SENT_ANALOG_START_ICW	✓		
STN_SENT_ANALOG_STOP_ICW	✓		
STN_SENT_STAND_ALONE_ICW	✓		
STOPPED_ANALOG_RX_WL_CALL	✓		
STOPPED_ANALOG_TX_WL_CALL	✓		
streaming still on	✓		
SWITCH_DEFAULT	✓		
TASK_SWARE_ERROR	✓		
tca task creation failed	✓		
tca task start failed	✓		
TestMsg partition create failed	✓		
TCH Create failed	✓		
TCH Start failed	✓		
Test Failed. L2 does not respond.	✓		
TIME_DATE_SET	✓		

**Table 5-1** Station / Comparator-Generated Status Messages (continued)

Station-Generated Status Message	Source		
	Internal System Status	Incorrectly Programmed RSS	Hardware Failure
TMON Create failed	✓		
TMON Start failed	✓		
TOD_LINK_DEGRADATION_OFF	✓		
TOD_LINK_DEGRADATION_ON	✓		
TOTAL_CD_ASSERTED	✓		
TOTAL_CD_LOST	✓		
TRACKING_1PPS_FAILURE			No 1 pps GPS input to station
Traffic timer expired Unexpectedly	✓		
Traffic timer expired while GOINGUP	✓		
TRUNKING_LC_OVERWRITE	✓		
TSTAT_FAILURE	✓		
txbdq create failed	✓		
TX block failed	✓		
tx_complete send failed	✓		
TX_DATA_RDY_DURING_IDLE	✓		
TX_EEPROM_CHECKSUM_FAILED	✓	Realign Exciter	
TX_FREQ_NOT_DIV_BY_5K_6250		Verify Programming	
TX_LOCK_ALARM		Incorrectly programmed transmit frequency on Channel Information Screen	Exciter
TX_POWER_LEVEL_ALARM			Exciter Power Amplifier
TX_SPI_RECEIVE_BUFF_FULL	✓		
TX_SYNTH_NOT_PROGRAMMABLE		Incorrectly programmed transmit frequency on Channel Information Screen	
TX_TO_HOST_CHKSUM_ERR	✓		
UHSO ALARM			
UHSO_COLD	✓		

**Table 5-1** Station / Comparator-Generated Status Messages (continued)

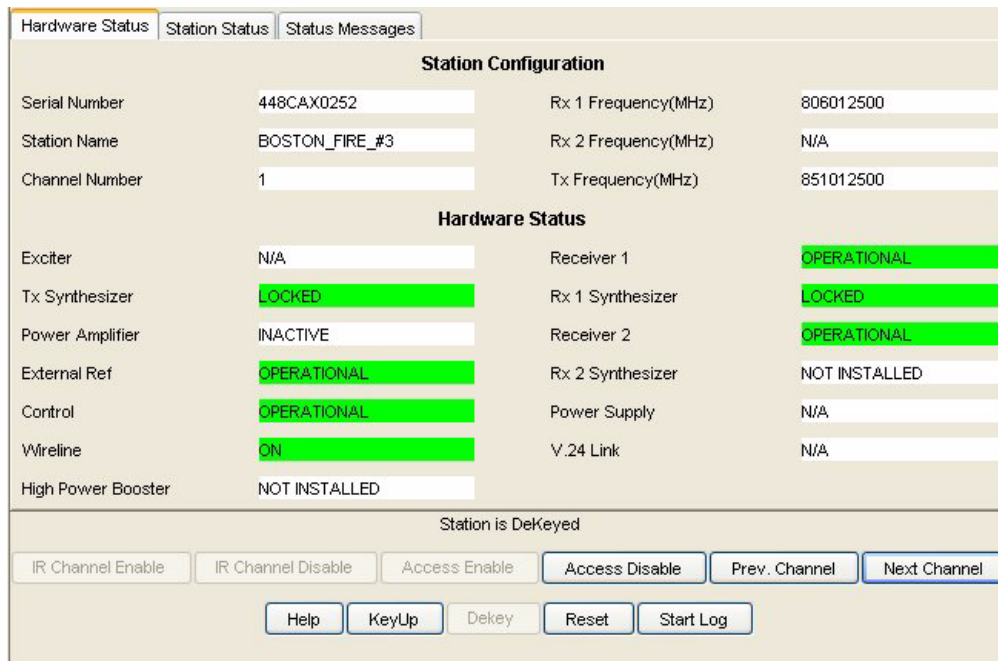
Station-Generated Status Message	Source		
	Internal System Status	Incorrectly Programmed RSS	Hardware Failure
UHSO_MANUAL_OVERRIDE	✓		
UHSO_WARM	✓		
UNABLE_ALLOCATE_MEMORY	✓		
UNABLE_TO_CALLOC_MEMORY	✓		
UNABLE_TO_OPEN_FILE	✓		
UNDEFINED ERRO	✓		
Unexpected DBS subsystem (source/target)	✓		
UNEXPECTED_ELSE	✓		
Unexpected event	✓		
Unexpected frame	✓		
Unexpected loopback result message	✓		
Unexpected message	✓		
UNEXPECTED_MSG_RESP	✓		
UNEXPECTED_OPCODE	✓		
UNEXPECTED_TERMINATION	✓		
UNEXPECTED_TIMER_MSG	✓		
Uninitialized error	✓		
UNKNOWN_EVNT_RECEIVED	✓		
unknown host or dl_cmd	✓		
Unknown idle option	✓		
UNKNOWN_MODEM_TRAIN_TYPE	✓		
Unknown SCCE event	✓		
UNKNOWN_SIMULCAST_STATE	✓		
UNKNOWN_TX_SPI_ERROR_CODE	✓		
Unrecognized base station alarm	✓		
UNSUPPORTED_INTERRUPT	✓		
Unsupported protocol type	✓		
V52_LAUNCH_TIME_ERR	✓		
VARIABLE_OUT_OF_RANGE	✓		

**Table 5-1** Station / Comparator-Generated Status Messages (continued)

Station-Generated Status Message	Source		
	Internal System Status	Incorrectly Programmed RSS	Hardware Failure
VERSION_MISMATCH	✓		
WB_PATH_ATTENUATION_MAX	✓		
WB_PATH_ATTENUATION_MIN	✓		
WC_NVM_PTTN_ERROR			Station Control
WL ALARM			Wireline
WL_DIG_CON_IS_DIGITAL	✓		
WL_DIG_CON_IS_MODEM	✓		
WL_LINK_TYPE_IS_MODEM	✓		
WL_LINK_TYPE_IS_V.24	✓		
WL_REQUESTED_RETRANSMIT	✓		
WL_STARTUP_ERROR		Verify RSS Programming	Wireline and/or firmware
WRITE_BYTE_COUNT_FAILURE	✓		
WRITE_NVM_FAILURE	✓		Station Control
WRITE_SOCKET_DATA_ERR	✓		
WRITE_TO_PROTECTED_TX_EEP	✓		
Wrong ack type	✓		
Wrong MDC ack type	✓		
XDATA_ERR	✓		

## Station Status Panel Screen

The Station Status Panel Screen provides three screens that display station maintenance and operational status information and station software version. Function keys allow you to control various station operating characteristics through the PC keyboard. See Figure 5-4 for the Station Status Panel screen example.



**Figure 5-4** Station Status Panel Screen Example

To generate station status, click **Status Panel Screen** in the navigation pane. Station operating and maintenance information appears. The buttons on the screen are described in Table 5-2.

**Table 5-2** Status Panel Screen Buttons

Button	Description
<b>General Buttons</b>	
Next Channel	Changes station operating channel incrementally
Prev channel	Changes station operating channel decrementally
IR Channel Enable	Enables repeater mode
IR Channel Disable	Disables repeater mode
KeyUp	Turns on station transmitter
Dekey	Turns off station transmitter
Reset	Performs a “warm” station reset (same reset as simultaneously pressing Vol Up, Vol Dn, and Intercom buttons on Station Control Module front panel).
Access Disable	Toggles Access Disable Mode on
Access Enable	Toggles Access Disable Mode off

**Table 5-2** Status Panel Screen Buttons (continued)

Button	Description
Start Log	Starts the logging of messages.
<b>Station Status</b>	
Local Speaker Volume >	Increments speaker volume in 5 unit steps
Local Speaker Volume <	Decrements speaker volume in 5 unit steps
Intercom On	Toggles Intercom mode on
Intercom Off	Toggles Intercom mode off
Rcvr Squelch OFF/CSQ/PL	Cycles through CSQ OFF, CSQ, and PL

## Comparator Status Panel Screen

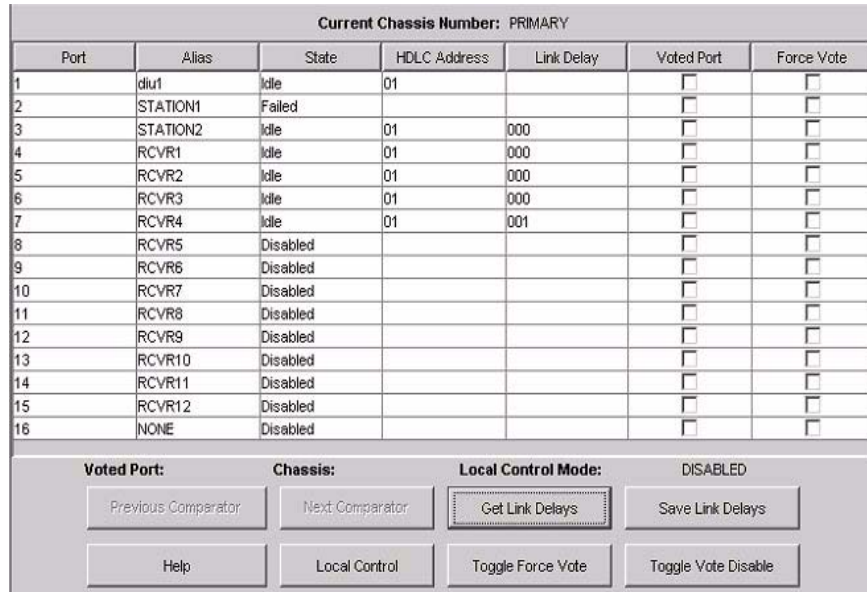
The comparator Status Panel Screen provides operational information about the comparator’s ports. See Figure 5-5 and Figure 5-6 for examples of this screen for the two comparator configurations.

Current Chassis Number: PRIMARY						
Port	Alias	State	HDLC Address	Link Delay	Voted Port	Force Vote
1	diu1	Failed			<input type="checkbox"/>	<input type="checkbox"/>
2	STATION1	Disabled			<input type="checkbox"/>	<input type="checkbox"/>
3	STATION2	Disabled			<input type="checkbox"/>	<input type="checkbox"/>
4	RCVR1	Disabled			<input type="checkbox"/>	<input type="checkbox"/>
5	RCVR2	Disabled			<input type="checkbox"/>	<input type="checkbox"/>
6	RCVR3	Disabled			<input type="checkbox"/>	<input type="checkbox"/>
7	RCVR4	Disabled			<input type="checkbox"/>	<input type="checkbox"/>
8	RCVR5	Disabled			<input type="checkbox"/>	<input type="checkbox"/>
9	RCVR6	Disabled			<input type="checkbox"/>	<input type="checkbox"/>
10	RCVR7	Disabled			<input type="checkbox"/>	<input type="checkbox"/>
11	RCVR8	Disabled			<input type="checkbox"/>	<input type="checkbox"/>
12	RCVR9	Disabled			<input type="checkbox"/>	<input type="checkbox"/>
13	RCVR10	Disabled			<input type="checkbox"/>	<input type="checkbox"/>
14	RCVR11	Disabled			<input type="checkbox"/>	<input type="checkbox"/>
15	RCVR12	Disabled			<input type="checkbox"/>	<input type="checkbox"/>
16	NONE	Disabled			<input type="checkbox"/>	<input type="checkbox"/>

<b>Voted Port:</b>	<b>Chassis:</b>	<b>Local Control Mode:</b>	DISABLED
Previous Comparator	Next Comparator	Get Link Delays	Save Link Delays
Help	Local Control	Toggle Force Vote	Toggle Vote Disable

**Figure 5-5** Status Panel Screen Example: Primary Comparator in an Expanded Configuration



**Figure 5-6** Status Panel Screen Example: Standard Comparator

After clicking Status Panel Screen in the navigation pane, various comparator operating and maintenance information appears. The buttons on the screen are described in Table 5-3.

**Table 5-3** Comparator Status Panel Screen Buttons

Button	Description
<b>General Buttons</b>	
Next Comparator	Changes comparator incrementally
Prev channel	Changes comparator decrementally
Get Link Delays	
Save Link Delays	
Help	Context sensitive help
Local Control	
Toggle Force Vote	
Toggle Vote Disable	
<b>Check Boxes</b>	
Vote Port	
Force Vote	

## Station/Comparator Software Version

The Version Screen provides the currently installed software versions. See Figure 5-7.

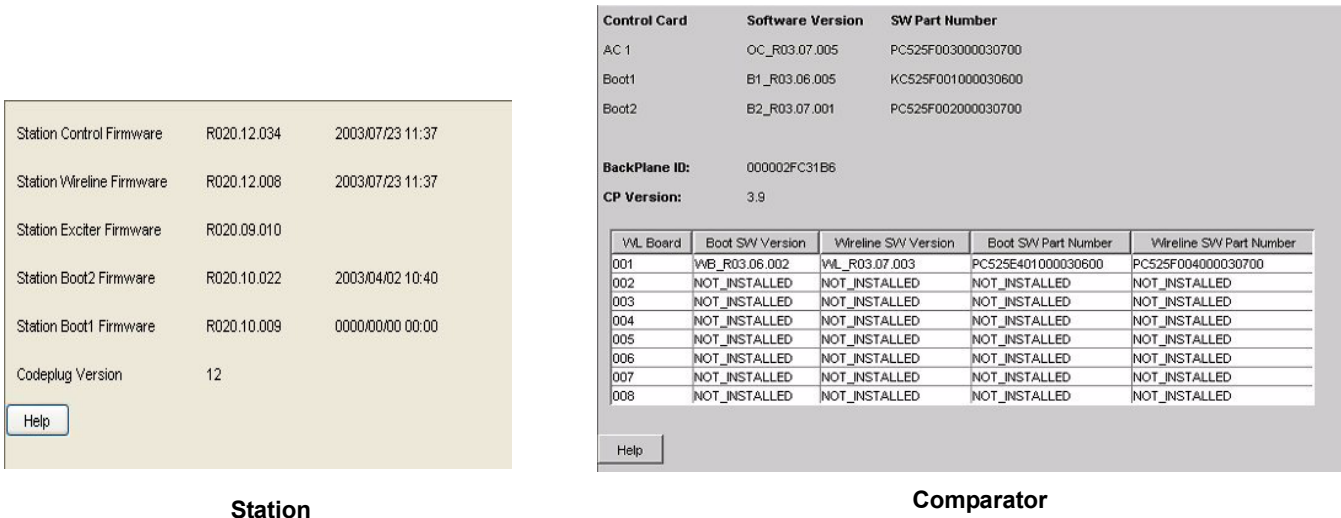


Figure 5-7 Station and Comparator Version Screens

## Setting Date and Time

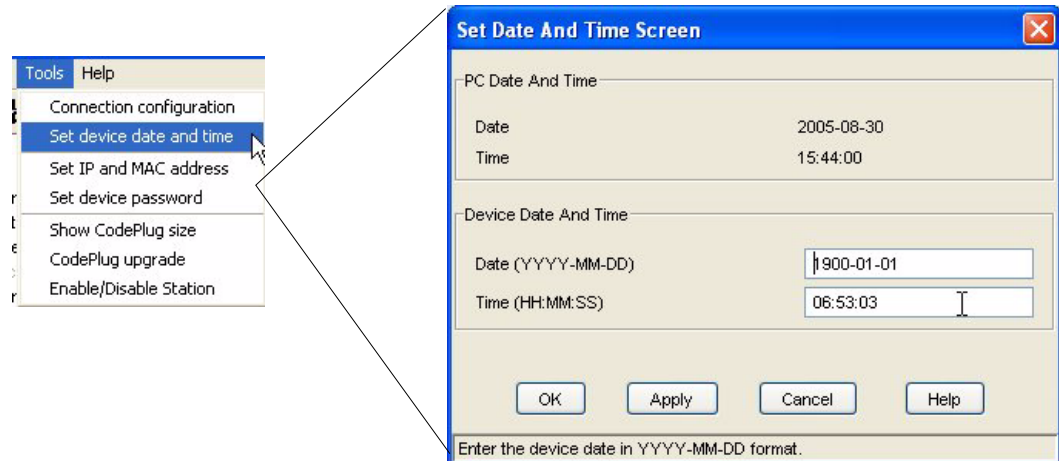
In most situations, the station's internal clock is set for the current date and time for the location in which it is installed. This ensures that timestamps associated with any status messages provide correlation with the actual time of occurrence of the event.

The PC Date and PC Time fields provide the current date and time of the PC's clock, and are not editable. The Device Date and Device Time fields are filled with the current date and time as read from the station. These fields are editable and can be changed to the requirements of any given installation.

To change the station's date and /or time, perform the following procedure:

1. From the **Tools** menu, select **Set device date and time**. The Set Date and Time Screen window appears.





2. Edit the Date and/or Time fields as required for the site's location.
3. Click **OK** to save the Date and Time to the device and close the window. Click **Apply** to save the Date and Time to the device without closing the window.

## Codeplug Reports

---

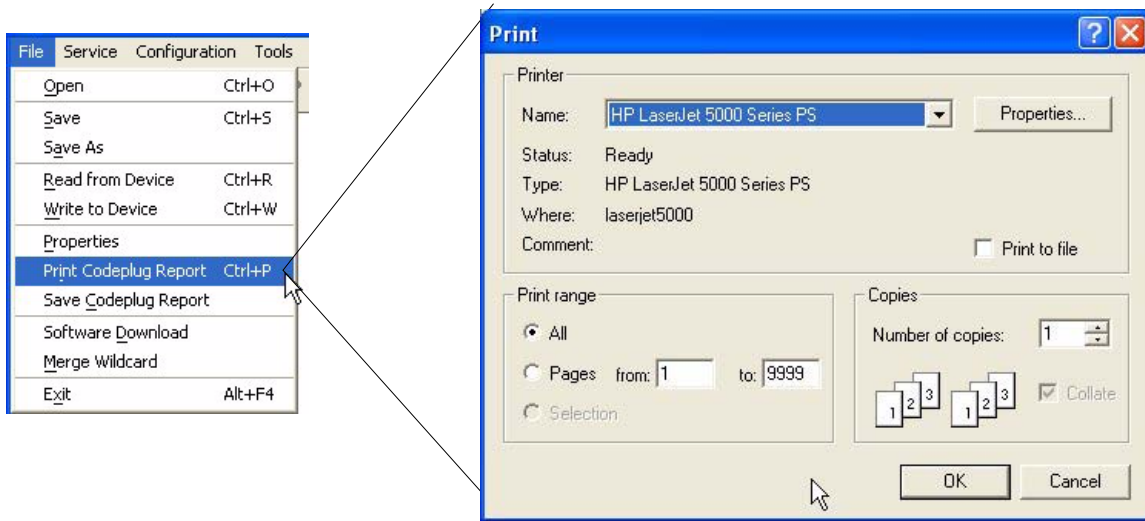
A text version of the codeplug parameters and current settings may be:

- Printed to a printer connected to the PC: See “Printing a Codeplug Report” on page 5-31.
- Saved to a file on the PC hard disk: See “Saving the Codeplug Report to a File” on page 5-32.

## Printing a Codeplug Report

To print the codeplug report on paper, perform the following procedure:

1. From the **File** menu, select **Print Codeplug Report**. The Print window appears.

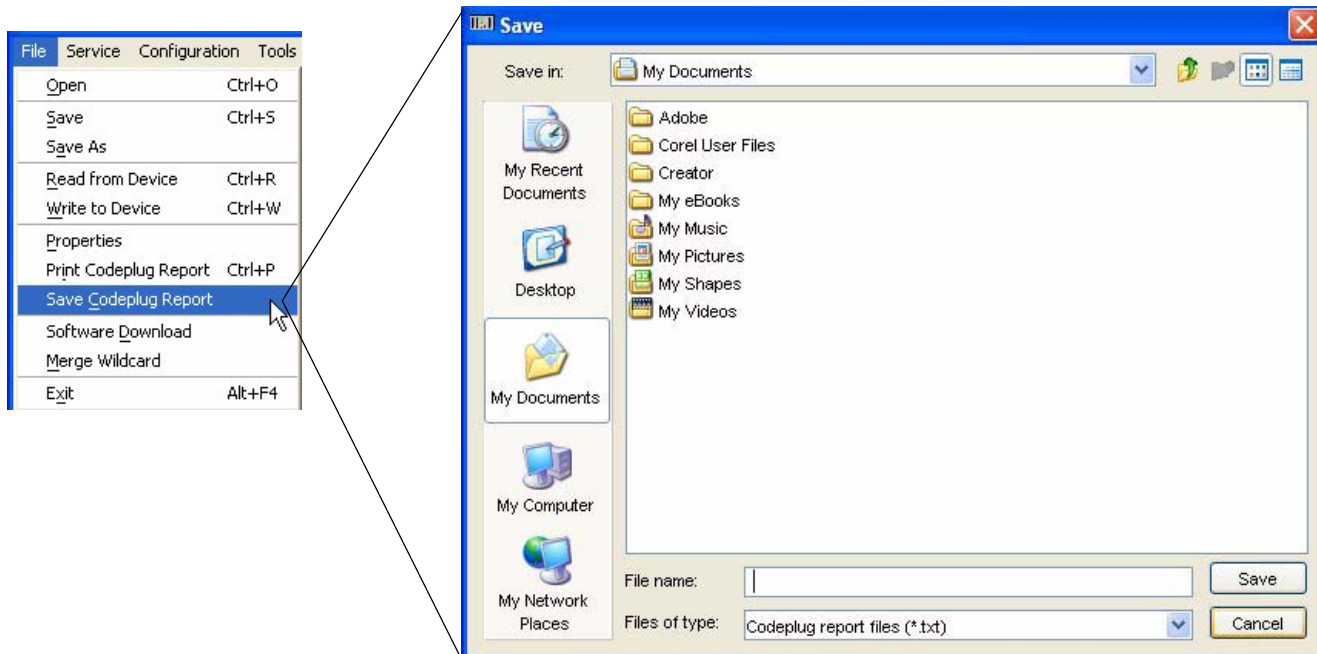


2. If required, configure the printer connected to the RSS PC and then click **Print**. The RSS program formats the report and sends it to the printer.

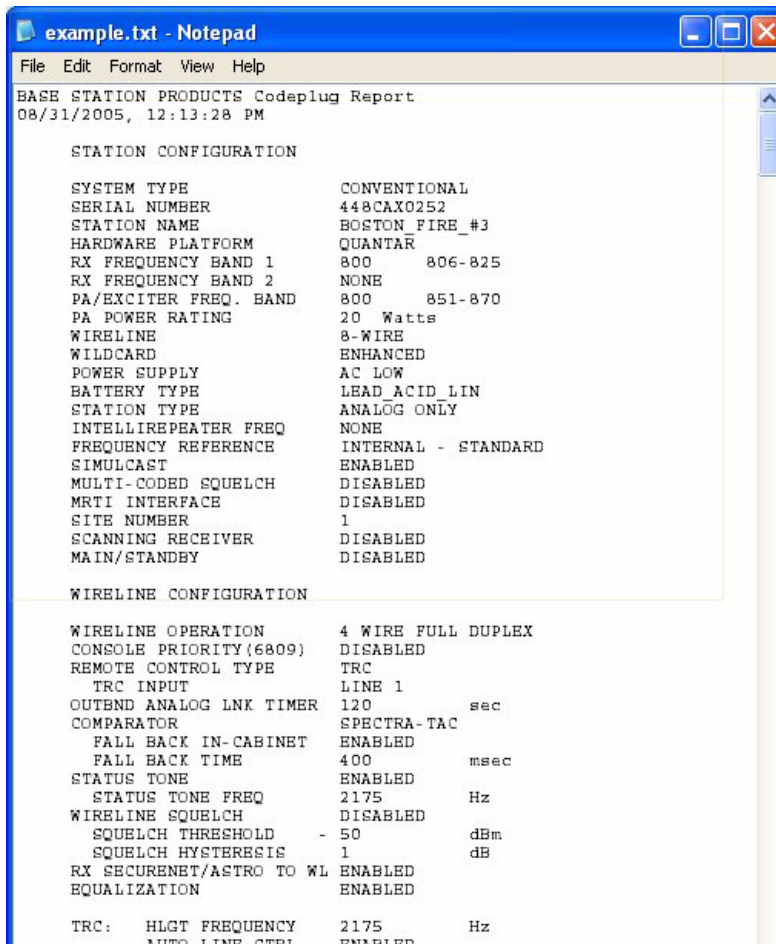
## Saving the Codeplug Report to a File

To save the codeplug report to a file, perform the following procedure:

1. From the **File** menu, select **Save Codeplug Report**. The following browser window appears.



2. If required, browse to the directory where you want to store the codeplug data text file.
3. Name the file by typing the filename in the Filename field. The file is saved as a .txt file.
4. Click **Save**. The RSS program formats and then saves the codeplug data text file to disk. Figure 5-8 provides an example of a saved codeplug report opened using a text editor.



```

example.txt - Notepad
File Edit Format View Help
BASE STATION PRODUCTS Codeplug Report
08/31/2005, 12:13:28 PM

STATION CONFIGURATION

SYSTEM TYPE             CONVENTIONAL
SERIAL NUMBER           448CAX0252
STATION NAME            BOSTON FIRE_#3
HARDWARE PLATFORM      QUANTAR
RX FREQUENCY BAND 1    800      806-825
RX FREQUENCY BAND 2    NONE
PA/EXCITER FREQ. BAND 800      851-870
PA POWER RATING        20 Watts
WIRELINE               8-WIRE
WILDCARD               ENHANCED
POWER SUPPLY           AC LOW
BATTERY TYPE           LEAD ACID LIN
STATION TYPE           ANALOG ONLY
INTELLIREPEATER FREQ  NONE
FREQUENCY REFERENCE    INTERNAL - STANDARD
SIMULCAST              ENABLED
MULTI-CODED SQUELCH    DISABLED
MRTI INTERFACE         DISABLED
SITE NUMBER            1
SCANNING RECEIVER      DISABLED
MAIN/STANDBY           DISABLED

WIRELINE CONFIGURATION

WIRELINE OPERATION     4 WIRE FULL DUPLEX
CONSOLE PRIORITY(6809) DISABLED
REMOTE CONTROL TYPE    TRC
  TRC INPUT             LINE 1
OUTBND ANALOG LNK TIMER 120      sec
COMPARATOR             SPECTRA-TAC
  FALL BACK IN-CABINET ENABLED
  FALL BACK TIME        400      msec
STATUS TONE            ENABLED
STATUS TONE FREQ       2175     Hz
WIRELINE SQUELCH       DISABLED
SQUELCH THRESHOLD      - 50      dBm
SQUELCH HYSTERESIS     1        dB
RX SECURENET/ASTRO TO WL ENABLED
EQUALIZATION           ENABLED

TRC:  HLGT FREQUENCY    2175     Hz
      AUTO LINE CTRL    ENABLED

```

Figure 5-8 Example of a Saved Codeplug Report

## Remote Station Disabling/Enabling

This feature is typically used to remotely disable and subsequently enable a station through an RSS dial-up connection. When disabled, the station operates in “RSS Only” mode and cannot transmit, receive, or respond to console commands. The station remains in this mode, even during power cycles and resets, until an Enable command is issued.

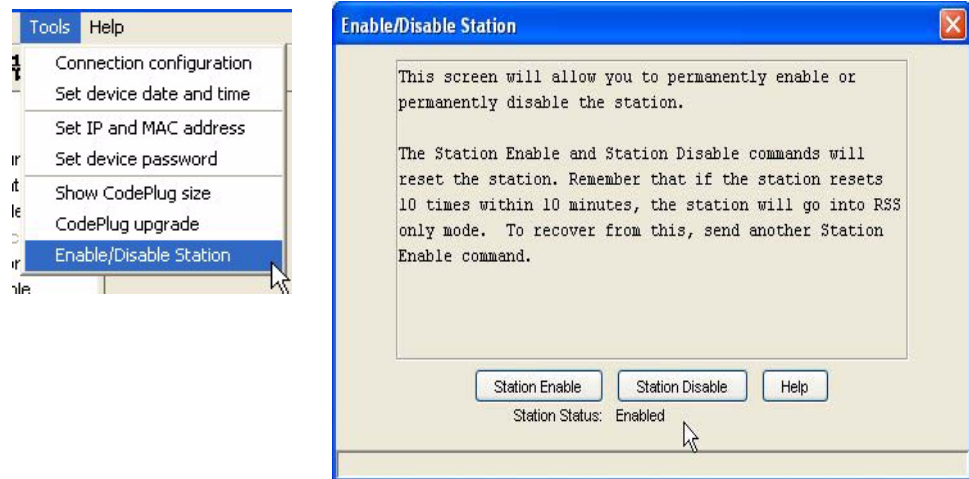


### NOTE

Disabling and enabling a station can also be performed locally through the RSS.

Perform this procedure while either locally connected to the station or connected remotely through a dial-up connection.

1. To enable or disable a connected station, from the **Tools** menu, select **Enable/Disable Station**. The Enable/Disable Station window appears.

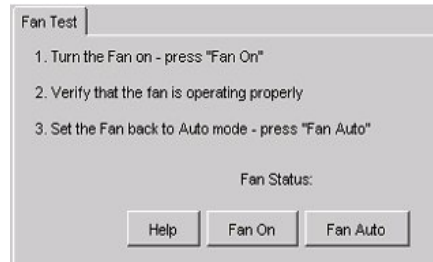


2. Depending on its current status (the three buttons at the bottom of the window), you can either enable or disable the station:
  - To disable: Click **Station Disable**. The station resets and commences RSS Only operating mode.
  - To enable: Click **Station Enable**. The station resets and commences normal operating mode.

## ASTRO-TAC Diagnostics

The comparator diagnostics screen verifies that the cooling fan functions properly. The fan turns on when the comparator's temperature reaches a predefined set point. To verify that the fan functions, perform the following procedure:

1. Click **Fan On**. See the example below.



2. Verify that the fan turns on. If the fan does not turn on, remove the comparator from service and contact Motorola to replace the fan.
3. If the fan functions, click **Fan Auto** to return the fan to automatic operation.

**THIS PAGE INTENTIONALLY LEFT BLANK.**

# Performing Post Repair Alignment

---

Following replacement of certain station modules, as described in the Troubleshooting section of the appropriate station functional service manual, alignment procedures may need to be performed before placing the station back into service. The RSS program provides access to the alignment routines required by QUANTAR/Quantro station modules.

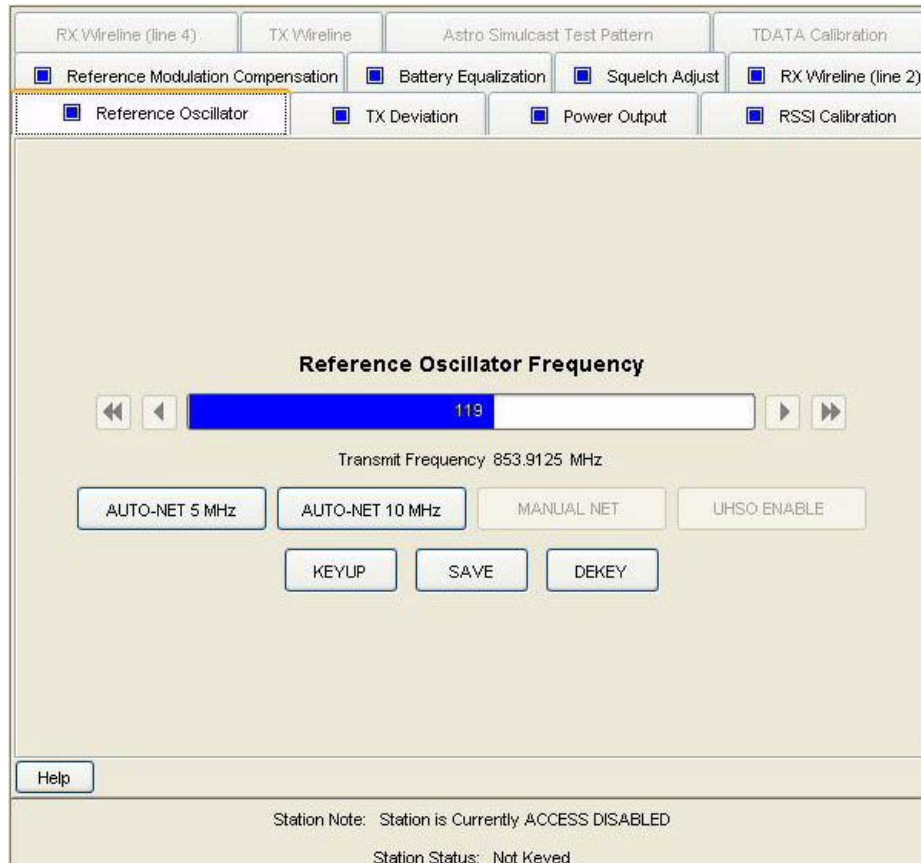
## Overview of Alignment Routines

---

The Alignment screens (see Figure 6-1) show the available alignment routines for the QUANTAR/Quantro station products. The following is an overview of each alignment routine:

- **Rx Wireline (Line2/Line 4):** Sets the desired wireline level that results from an RF receive signal at 60% of system rated deviation.
- **Tx Wireline:** Calibrates the gain of certain audio circuits on the wireline interface board so that the desired level of audio signal from console results in a transmitted signal at 60% of rated system deviation.
- **RSSI Calibrate:** Calibrates the receiver circuitry used to derive the level of the received RF signal.
- **Squelch Adjust:** Provides the capability to set the level at which the receiver unsquelches.
- **Battery Equalization:** Maintains proper charge and capacity for storage batteries.
- **Reference Oscillator (or UHSO):** Calibrates the station reference oscillator circuit (located in the station control module) to within the required frequency tolerance.
- **ASTRO Alignment and Test:** Provides the capability to set the amount of delay (unique to each site) before transmission for station in an ASTRO simulcast system.
- **ASTRO Pattern Generator:** Allows the station to generate one of four ASTRO Project 25 test patterns for display and analysis on an R2670 analyzer.
- **TDATA Calibration:** Calibrates deviation for low speed data signal from 6809 central controller.
- **Power Output:** Calibrates the output power at the PA rated level. On Quantro stations, it calibrates the wattmeter, if installed.

- **Tx Deviation Gain Adjust:** Calibrates deviation-limiting hardware and software for transmit linearity over entire Tx frequency range.
- **Reference Modulation Compensation:** Calibrates for low-frequency transmit deviation linearity for DPL and data (including ASTRO) signals.



**Figure 6-1** Reference Oscillator Alignment Screen

This chapter provides procedures for those alignment procedures not described elsewhere in this guide or the station functional manual. Table 6-1 lists each alignment routine and where to find the corresponding procedure. Note that some alignment routines must be performed as part of routine maintenance and/or at the time of equipment installation, as indicated in parentheses on the alignment screen.

**Table 6-1** Alignment Procedures

Alignment Routine	When Required	Location
Rx Wireline (Line 2/Line 4)	Station control module	“Procedure A: Rx Wireline Alignment Procedure” on page 3-57
Tx Wireline	<ul style="list-style-type: none"> <li>• Wireline interface module</li> <li>• Station control module</li> </ul>	“Procedure E: Aligning TX Wireline Procedure” on page 3-66
RSSI Calibrate	<ul style="list-style-type: none"> <li>• Receiver module</li> <li>• Station control module</li> </ul>	“Aligning Radio Signal Strength Indicator (RSSI)” on page 3-68



**Table 6-1** Alignment Procedures (continued)

Alignment Routine	When Required	Location
Squelch Adjust	<ul style="list-style-type: none"> <li>Receiver module</li> <li>Station control module</li> </ul>	“Aligning Squelch Adjust Procedure” on page 3-71
Battery Equalization	Routine maintenance only	“Equalizing Batteries” on page 3-73
Reference Oscillator (or UHSO)	Station control module	“Calibrating Reference Oscillator Procedure” on page 3-75
ASTRO Alignment and Test	Station control module	“Setting ASTRO Tx Align and Test Procedure” on page 3-82
ASTRO Pattern Generator	Station control module	“Generating ASTRO Test Patterns” on page 3-85
TDATA Calibration	Station control module	“TDATA Calibration (6809 Trunking Station Only)” on page 3-88
Power Output	<ul style="list-style-type: none"> <li>Power amplifier module</li> <li>Station control module</li> </ul>	“Aligning Power Output Procedure” on page 6-4 or “Aligning Power Output Procedure for a Quantro 350W VHF Station” on page 6-7
Tx Deviation Gain Adjust	<ul style="list-style-type: none"> <li>Exciter module</li> <li>Station control module</li> </ul>	“Aligning Tx Deviation Gain Adjust Procedure, 350W VHF Stations” on page 6-11
Reference Modulation Compensation	<ul style="list-style-type: none"> <li>Exciter module</li> <li>Station control module</li> </ul>	“Aligning Reference Modulation Compensation Procedure” on page 6-14

**IMPORTANT**

Before performing any of the station alignment procedures, you must dekey the station transmitter. Click **Access Disable** from any alignment screen to access disable the station. When finished with alignment, click **Access Enable** to deactivate access disable and restore the station to normal operation.

**IMPORTANT**

When entering data in any of the alignment screens' fields, you must click **Save** to accept the entry and save the changed value to the station. If you alter a parameter value and exit the particular alignment screen without saving the changed value, the station continues to operate using the changed value only until a station reset occurs (either deliberately or due to an external cause, such as a momentary power failure).

**NOTE**

If you “experiment” with a parameter value without intending to permanently change the value, you must remember not to save the value and to reset the station to restore the original parameter value(s).

## Test Equipment for Post-Repair Alignment Procedures

Performing the alignment procedures requires using the RSS program in conjunction with the following test equipment:

- Motorola R2001/R2670 communications analyzer (or equivalent)
- In-line wattmeter adapter (RTL4055B or equivalent)
- In-line wattmeter elements (ST1200 series or equivalent)

This equipment is used to inject and monitor test signals. The RSS provides the means of adjusting various alignment parameters.

## Aligning Power Output Procedure



### NOTE

This procedure is not for the Quantro 350W VHF station. If you are aligning a Quantro 350W station, refer “Aligning Power Output Procedure for a Quantro 350W VHF Station” on page 6-7.

This procedure is for QUANTAR stations with and without the high power booster option because it is the power amplifier module internal to the QUANTAR station that requires alignment, not the high power booster module. To align the station’s power output, perform the following procedure:

1. Connect the station as shown in Figure 6-2.



### NOTE

An R2001 communications analyzer may be used as a wattmeter.

1. Remove N-type connector from PA output
2. Connect cable from wattmeter

Note: For Quantro stations, connect wattmeter to output of low pass filter

Note: Keep this cable as short as possible.

In-line wattmeter adapter and element

To TX antenna or dummy load

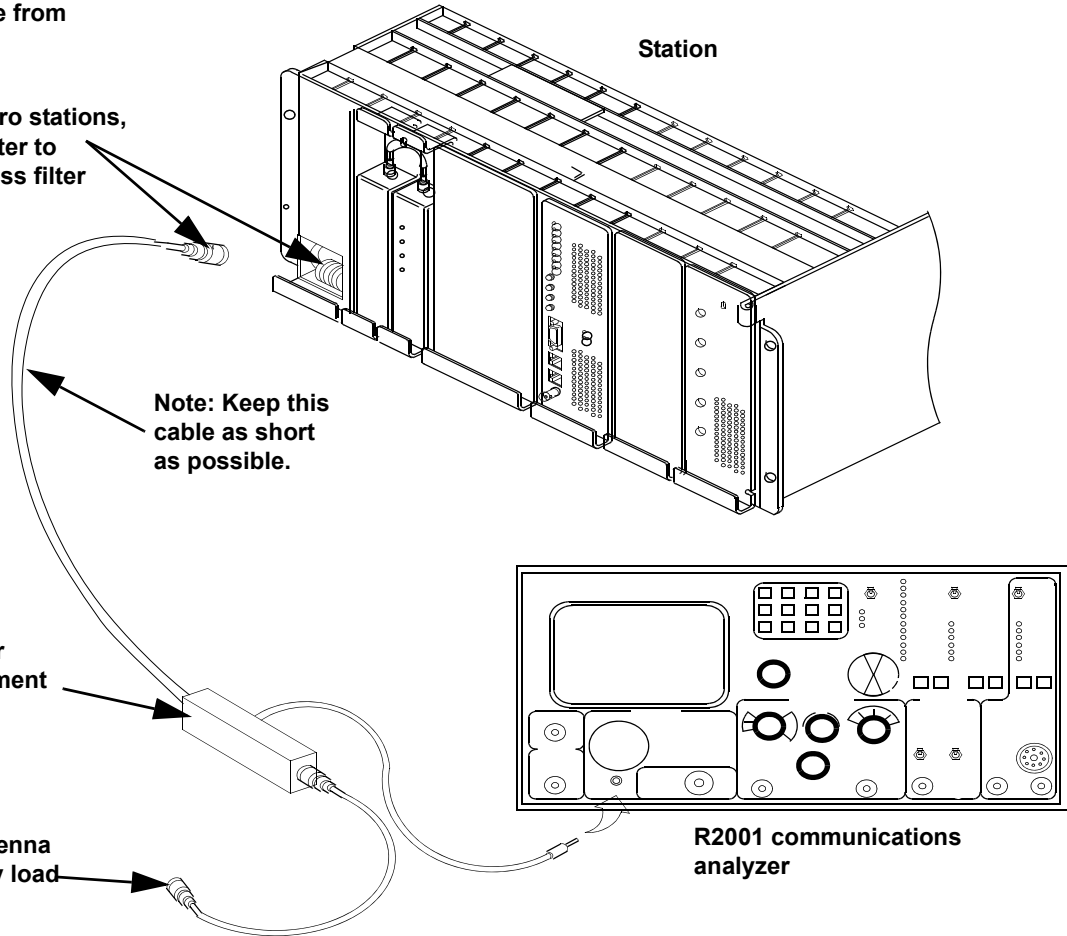


Figure 6-2 Power Output Alignment Setup

2. Set the R2001 analyzer **Display** to Monitor mode.
3. Click **Alignment Screens** under Service in the navigation pane. The Alignment screen appears.
4. Click the **Power Output** tab. The Power Output screen appears.

The screenshot shows the 'Base Radio' configuration software. On the left is a navigation tree with 'Configuration' and 'Service' sections. The main area has several tabs: 'RX Wireline (line 4)', 'TX Wireline', 'Astro Simulcast Test Pattern', 'TDATA Calibration', 'Reference Modulation Compensation', 'Battery Equalization', 'Squelch Adjust', 'RX Wireline (line 2)', 'Reference Oscillator', 'TX Deviation', 'Power Output', and 'RSSI Calibration'. The 'Power Output' tab is active, displaying the following information:

Rated Power Out 20 WATTS  
 Power Read on Wattmeter 0.01 WATTS  
 Transmit Frequency 853.9125 MHz

Instructions:

- 1) Press the PA INIT button.
- 2) KEYUP the Station.
- 3) Enter power read on the wattmeter.
- 4) Press the ADJUST button and wait for Station response.
- 5) If the Station is at desired power, press the SAVE button.
- 6) If the station is not at desired power, repeat steps 3 and 4.

Note: If an error occurs during adjustment, press the PA INIT button to clear the error and set the PA to an initial value. Restart the alignment process.

Buttons: PA INIT, KEYUP, ADJUST, SAVE, DEKEY

Help button at the bottom left.

Station Note: Station is Currently ACCESS DISABLED  
 Station Status: Not Keyed

5. Click **KEYUP**.
6. Read the power output as displayed by the wattmeter.
7. Enter the value displayed by the wattmeter into the **Power Read on Wattmeter** field.
8. Click **ADJUST**. The station automatically adjusts its output power.



#### NOTE

The power value displayed in the Rated Power Out field is determined by the PA Power Rating selection in the Hardware Configuration screen. The value may differ from the rated station power if the station is equipped with a circulator(s). For example, a 225W station equipped with the triple circulator option results in 170W in the Desired Power Out field (and thereafter the power amplifier is calibrated at 170W). Refer to the Help screen for a listing of output power versus PA/circulator combinations.

9. Click **KEYUP** to verify that the station correctly adjusted its output power to its rated value.
  - If the PA FAIL LED turns on during the alignment procedure, click **PA INIT** and proceed to step 5.

- If the output power displayed on the wattmeter is not at the rated level, proceed to step 6.
  - If the output power displayed on the wattmeter is at the rated level, proceed to step 10.
10. Click **SAVE** to save the calibrated value in memory. This may take up to 12 seconds.

## Aligning Power Output Procedure for a Quantro 350W VHF Station

---

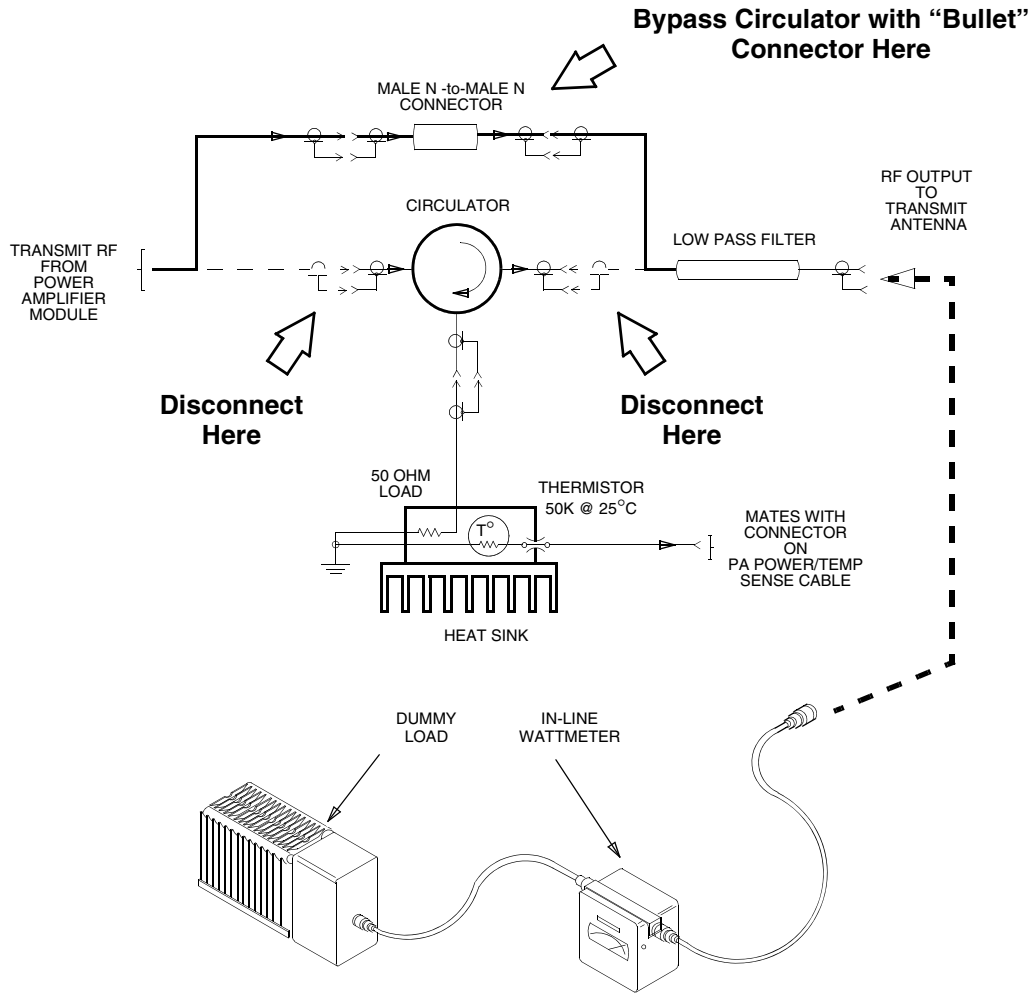
This procedure is for Quantro 350W stations only. To align the station's power output, perform the following procedure:

1. Connect the station as shown in Figure 6-3.



### NOTE

The circulator is bypassed using a male N-to-male N bullet connector (supplied with the station) and requires the dummy load.



**Figure 6-3** Power Output Alignment Setup for Quantro 350W Stations

2. Click Hardware Configuration in the navigation pane. The Hardware Configuration screen appears.

Serial Number: 448CAX0252 Station Name: BOSTON\_FIRE\_#3

Hardware Platform: QUANTRO

System Type: CONVENTIONAL Station Type: ANALOG ONLY

Rx Freq Band 1: VHF\_R2 150-174 MHz Tx Freq Band: VHF\_R2 150-174 MHz

Rx Freq Band 2: NONE MHz

PA Power Rating: 350 Watts with No Circulator

Power Supply: QUAN... Battery Type: NONE

Options

Wireline: 8-WIRE WildCard: ENHANCED

Freq Ref: INTERNAL - STANDARD Simulcast Operation: ENABLED

Multi-Coded Squelch: DISABLED Phone Patch Interface: DISABLED

Scanning Receiver: DISABLED

Main/Standby: DISABLED

Buttons: Help, Validate Configuration

3. Select 350 Watts with No circulator in the **PA Power Rating** drop down list.
4. Click **Channel Information** in the navigation pane, then click the **Advanced** tab. The Advanced Channel Information screen appears.

Channel Number: 1 CHANNEL# 1 of 4

Basic Advanced

Tx Power Out

Normal: 350 Watts Battery Backup: 170 Watts

Repeater

Drop Out Delay: 10 sec

Audio Hold-Off: 0 msec

Time Out Timers

Wireline: 120 sec Local: 0 sec

Repeater: 60 sec Phone Patch: 0 sec

Hear Clear

Componder: DISABLED

Noise Canceller: DISABLED

Alarm Tone

Over Air: DISABLED Over Wireline: ENABLED

Phone Patch Operation: DISABLED

Audio Filters

Pre-emphasis: ENABLED

De-emphasis: ENABLED Hi-Pass Filter: ENABLED

Rcv Signal Inversion: DISABLED

PTT Priority: W>R>M>D>L

Analog Repeater Boost: DISABLED

Buttons: Help, Add Channel, Previous Channel, Next Channel, Delete Channel

- Set the Tx Power Out value to the desired station output power **plus** 40W. For example, if the desired output power is 250W then you enter 290W in the Tx Power Out field. This compensates for the fact that the output power alignment measurement point is changed from *after* the circulator to *before* the circulator.



### NOTE

Although you can enter 350W in the Tx Power Out field, the maximum output power, after the circulator, is limited to 310W.

- Click Alignment Screens under Service in the navigation pane. The Alignment screen appears.
- Click the **Power Output** tab. The Power Output screen appears.

The screenshot shows the 'Power Output' screen with the following details:

- Navigation Pane:** Base Radio > Configuration > Service > Alignment Screen
- Screen Tabs:** RX Wireline (line 4), TX Wireline, Astro Simulcast Test Pattern, TDATA Calibration, Reference Modulation Compensation, Battery Equalization, Squelch Adjust, RX Wireline (line 2), Reference Oscillator, TX Deviation, Power Output (selected), RSSI Calibration
- Display Fields:**
  - Rated Power Out: 20 WATTS
  - Power Read on Wattmeter: 0.01 WATTS
  - Transmit Frequency: 853.9125 MHz
- Instructions:**
  - 1) Press the PA INIT button.
  - 2) KEYUP the Station.
  - 3) Enter power read on the wattmeter.
  - 4) Press the ADJUST button and wait for Station response.
  - 5) If the Station is at desired power, press the SAVE button.
  - 6) If the station is not at desired power, repeat steps 3 and 4.
- Note:** If an error occurs during adjustment, press the PA INIT button to clear the error and set the PA to an initial value. Restart the alignment process.
- Buttons:** PA INIT, KEYUP, ADJUST, SAVE, DEKEY

- Click **KEYUP**.
- Read the power output as displayed by the wattmeter.
- Enter the value displayed by the wattmeter into the Power Read on Wattmeter field.
- Click **ADJUST**. The station automatically adjusts its output power.
- Click **KEYUP** to verify that the station correctly adjusted its output power to its rated value.
  - If the PA FAIL LED turns on during the alignment procedure, click **PA INIT** and proceed to step 8.
  - If the output power displayed on the wattmeter is not at the rated level, proceed to step 9.



- If the output power displayed on the wattmeter is at the rated level, proceed to step 13.
13. Click **SAVE** to save the calibrated value in memory. This may take up to 12 seconds.

## Aligning Tx Deviation Gain Adjust Procedure, 350W VHF Stations

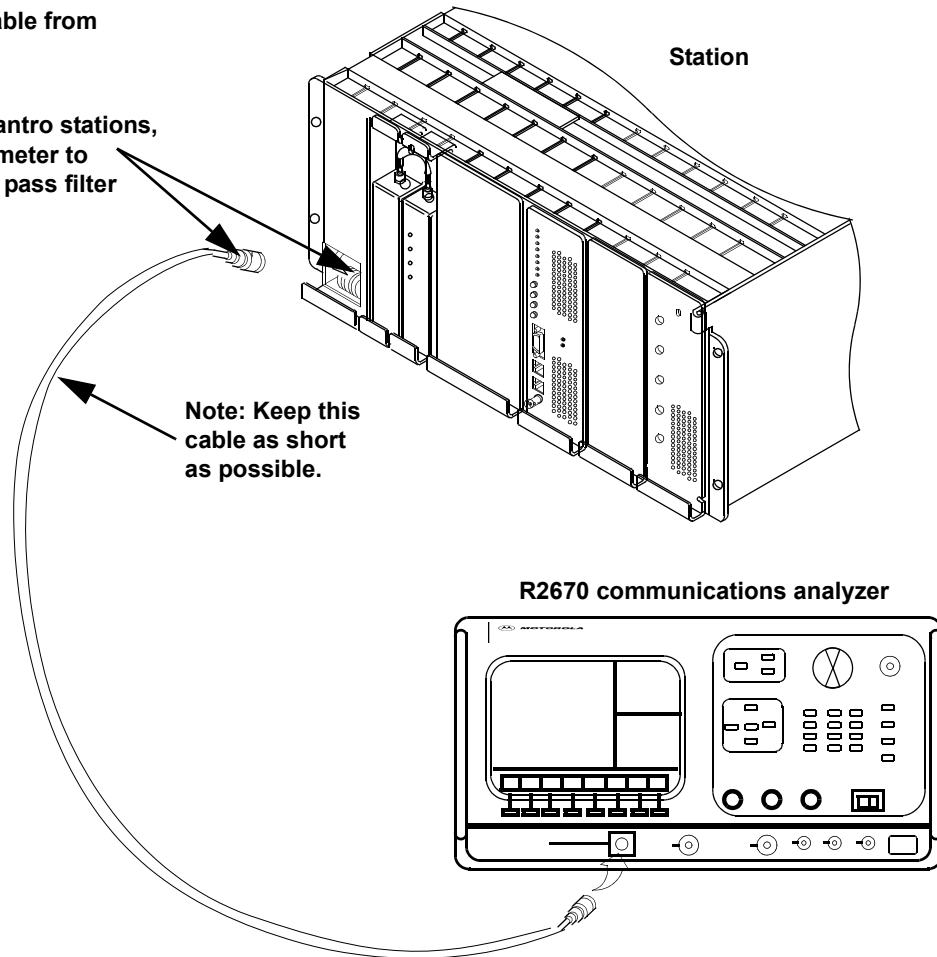
---

To set the station's Tx Deviation Gain Adjust, perform the following procedure:

1. Connect the station as shown in Figure 6-4.
2. Set the R2670 communications analyzer as follows:
  - **Display:** Set to Read Deviation
  - **Narrow Bandwidth- NB Filter:** Enabled
  - **High Pass Filter:** 5 Hz
  - **Low Pass Filter:** 20 kHz
  - **R2670 Firmware Version:** Must be 5.04.xx or later

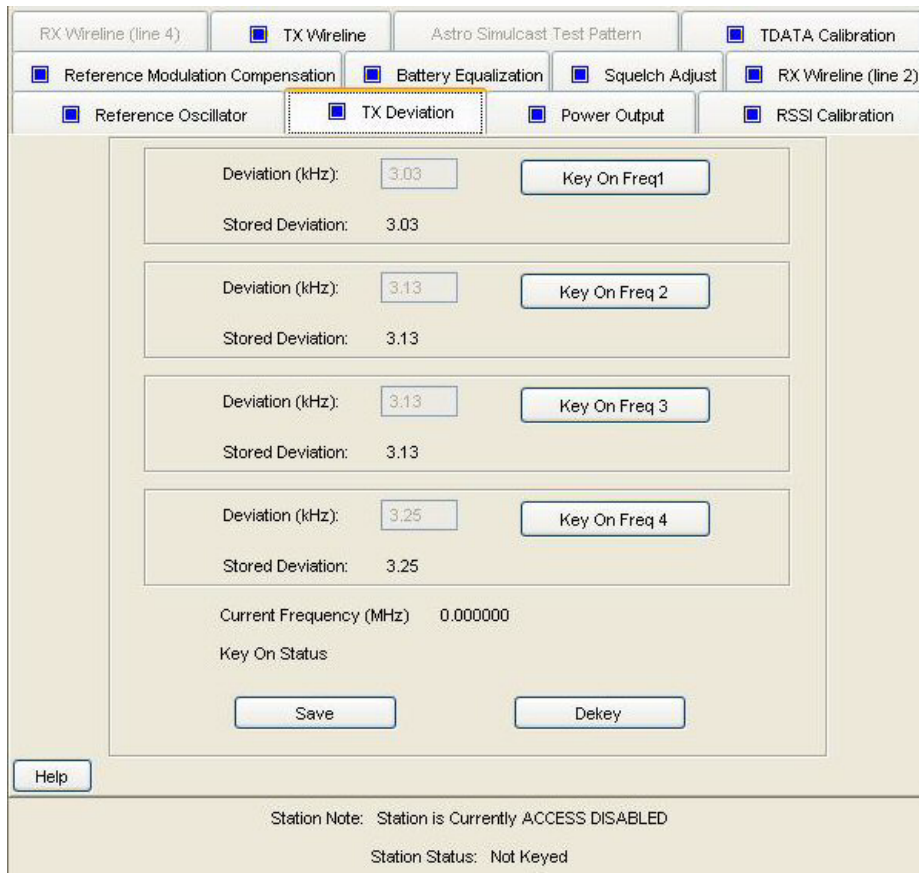
1. Remove N-type connector from PA output
2. Connect cable from wattmeter

**Note:** For Quantro stations, connect wattmeter to output of low pass filter



**Figure 6-4** Tx Deviation Gain Adjust Alignment Setup

3. Click **Alignment** in the navigation pane, then the **Tx Deviation** tab. The Tx Deviation screen appears.



4. Click **Key On Freq1**.



**NOTE**

To avoid overloading the R2670 RF input, the station automatically limits its power output to either one half power or approximately 100W, whichever is lower when this alignment is performed.

5. Set the R2670 analyzer to the value displayed in the **Current Frequency Is** field.
6. Read the deviation on the analyzer display (shown as two numbers; one for + and one for -). Enter the larger number into the Deviation (kHz) field for the first frequency.
7. Click **DEKEY**.
8. Repeat steps 4 through 7 for Freq2, Freq3, and Freq4. When done, click **SAVE** to save the values.

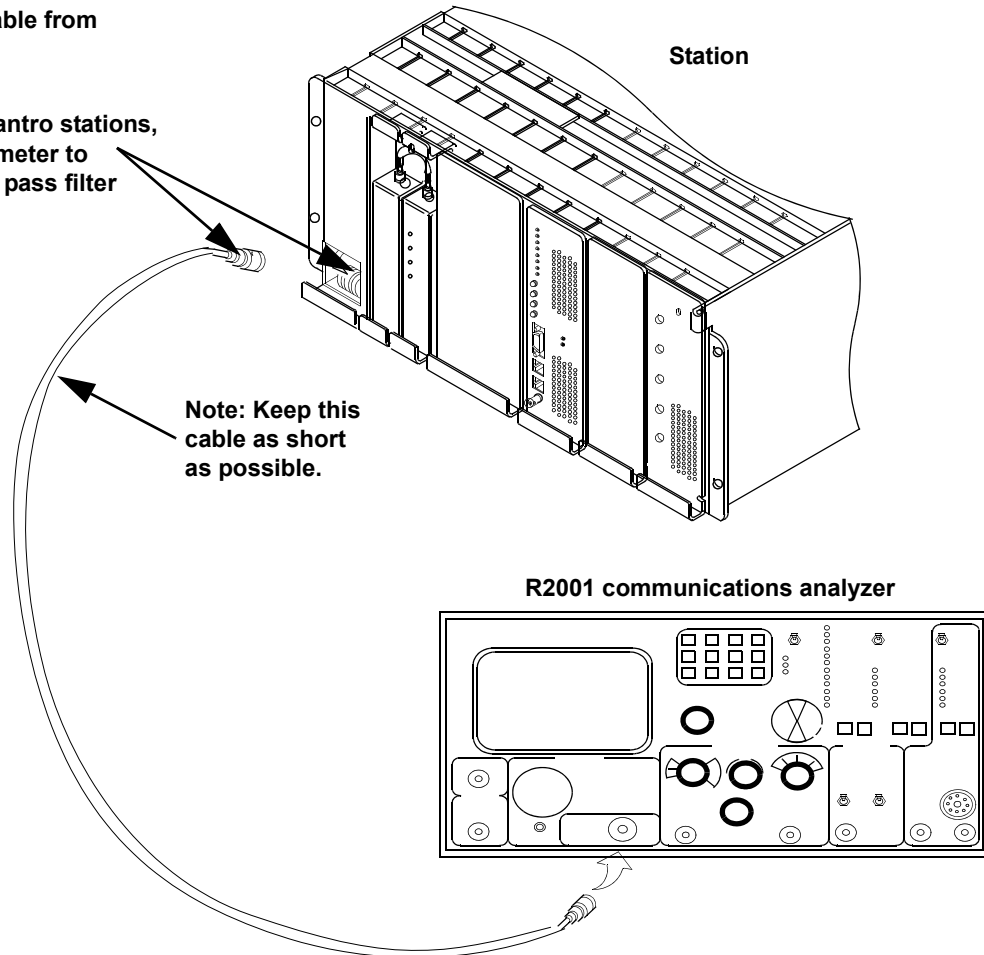
# Aligning Reference Modulation Compensation Procedure

To set the Reference Modulation Compensation, perform the following procedure:

1. Connect the station as shown in Figure 6-5.

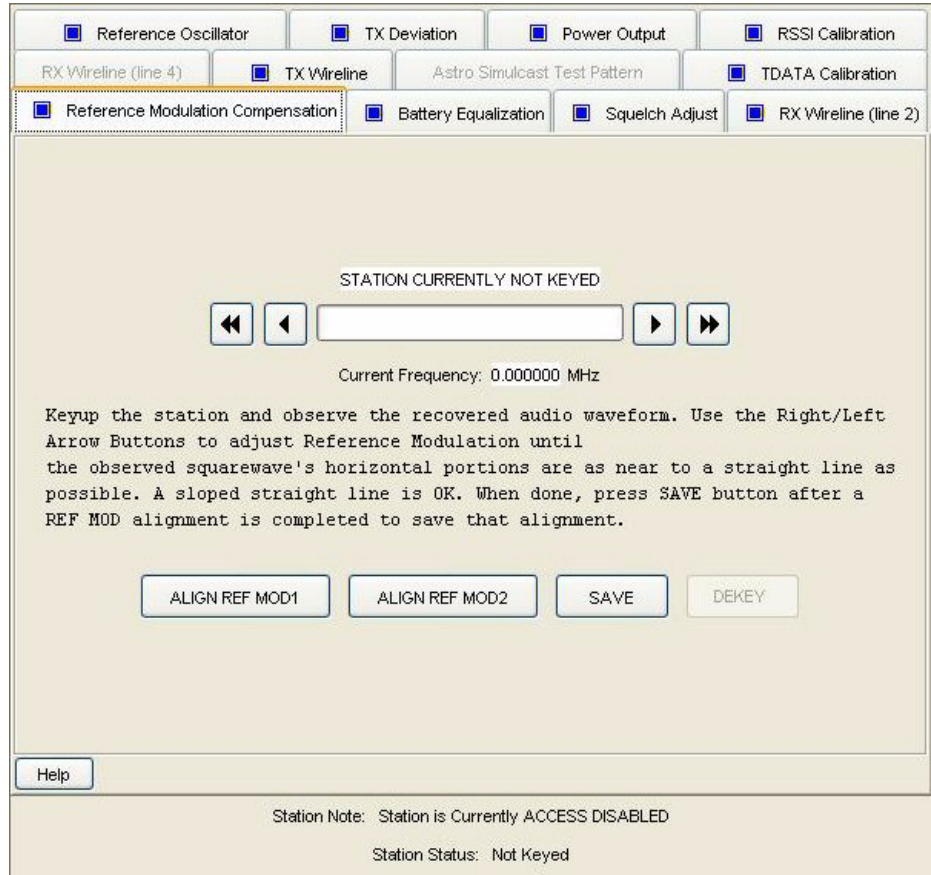
1. Remove N-type connector from PA output
2. Connect cable from wattmeter

Note: For Quantro stations, connect wattmeter to output of low pass filter



**Figure 6-5** Reference Modulation Compensation Alignment Setup

2. Set the R2001 communications analyzer as follows:
  - **Frequency:** Tx frequency of station
  - **Display:** Set to read modulation
  - **Bandwidth:** Narrow
3. Click **Alignment** in the navigation pane then the **Reference Modulation Compensation** tab. The following Reference Modulation Compensation screen appears.



4. Click **ALIGN REF MOD1**.



**NOTE**

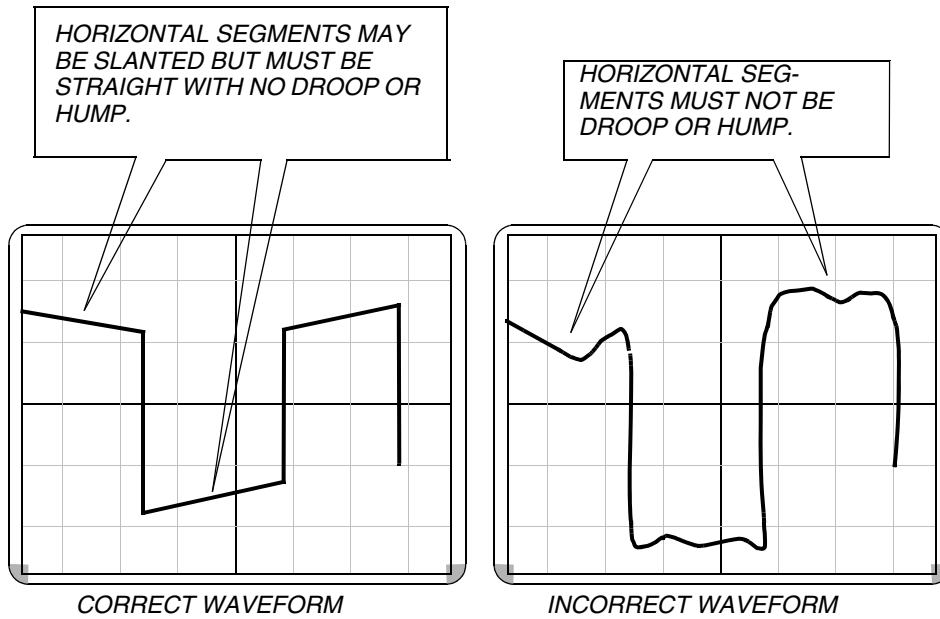
To avoid overloading the analyzer’s RF input, the station automatically limits its power output to either one half power or approximately 100 W, whichever is lower when this alignment is performed.

5. Set the analyzer to the transmit frequency displayed in the Current Frequency: field. The analyzer should display a square wave at approximately 10 Hz as shown in Figure 6-6. The horizontal segments of the waveform should be as straight as possible, with no noticeable droops or bumps.



**NOTE**

Adjust the oscilloscope to be able to adequately view the waveform during alignment.



**Figure 6-6** Waveform Examples

- If the waveform is acceptable, click **SAVE** and proceed to step 7.
  - If the waveform is not acceptable, click either the right or left arrows to adjust the station's output until the waveform is acceptable. Click **SAVE** and proceed to step 5.
6. Click **DEKEY**.
  7. Perform steps 5 through 7 for ALIGN REF MOD2.

# Version Compatibility and Upgrades

---

Periodically, Motorola may release an upgraded version of the RSS program with a companion release of station firmware. Each upgraded version typically provides support for new station features. The following information provides details on RSS compatibility and the relationship between the RSS program, station firmware, and station hardware.

Associated with each RSS version, are corresponding station firmware versions. QUANTAR firmware releases prior to R9.00 consisted of a four IC EPROM set for the station control board, a two EPROM set for the wireline board and one EPROM for the exciter. QUANTAR release R9.00 and later releases utilized a Flash download to a single SIMM on the station control board which also contains the wireline firmware version. The exciter board continues to use a single EPROM.

## Prior to Release R07.02.02

---

The release numbering format for all RSS releases prior to R07.02.02 is RX.XX with each major release resulting in an incremented release number, such as R1.00 to R2.00, and minor releases resulting in an incremented point number, such as R3.01. For the RSS, this release number is printed on the RSS CD and appears in the About window.



### NOTE

The release numbering scheme was not implemented in the initial release of the RSS and station firmware. The initial RSS release was numbered R01.19.17. This version is considered release R1.00.

## Beginning with Release R7.02.02

---

The release numbering format for all RSS releases beginning with R7.02.02 is RXX.XX.XX, with each major release resulting in an incremented release number such as R08.00.00 to R09.00.00, minor releases resulting in the middle two digits being incremented, such as R09.01.00, and maintenance releases resulting in the last two digits being incremented, such as R09.01.01. For this RSS, the release number is printed on the RSS CD and appears in the About window.



### NOTE

When contacting Motorola for RSS technical support, be sure to provide the complete version information as displayed in the About window by clicking **Version Details**.

## RSS Program Version and Station Firmware Relationship

---

Each RSS program version is accompanied with a simultaneous upgrade release of the station software. Table 7-1 through Table 7-6 describe the relationships between RSS program versions, IC part numbers and conventional, 6809 trunking, and IntelliRepeater station software versions.



**Table 7-1** TRN7475<sup>1</sup> and TRN7667<sup>1</sup> Station Control Boards RSS Compatibility

RSS Version Release	Conventional/6809 Trunking			IntelliRepeater/SmartZone		
	Release	IC/ Part No.	Firmware Version <sup>2</sup>	Release	IC/ Part No.	Firmware Version <sup>2</sup>
R1.00 (called R01.19.17)	R1.00 (Conventional Only)	SCM: U653 5191020C41 U654 5191020C42 WL: U134 5191013H14 U135 5191013H13 EXC: U3701 5191012L68	SCM: B011.01.009 WL: B011.01.006 EXC: B011.01.003	SZ2.0	SCM: U653 5191022C03 U654 5191022C04 WL: U134 5191013H12 U135 5191013H11 EXC: U3701 5191012H98	IR: 8.14 Comb WL: 930504 EXC: 7.11
R2.00	R2.00	SCM: U653 5191020C47 U654 5191020C48 WL: U134 5191013H18 U135 5191013H17 EXC: U3701 5191012L71	SCM: B013.02.015 WL: B013.02.007 EXC: B013.02.004	SZ2.3	SCM: U653 5191022C05 U654 5191022C06 WL: U134 5191013H18 U135 5191013H17 EXC: U3701 5191012L71	IR: 10.26 WLB: B013.02.007 EXC: B013.02.004
R3.00	R3.00	SCM: U653 5191020C49 U654 5191020C50 WL: U134 5191013H20 U135 5191013H19 EXC: U3701 5191012L72	SCM: B013.03.007 WL: B013.03.003 EXC: B013.03.003	SZ2.7	SCM: U653 5191022C11 U654 5191022C12 WL: U134 5191013H22 U135 5191013H21 EXC: U3701 5181012L73	IR: 11.69 WL: B013.03.007 EXC: B013.03.006
R3.01	R3.01	SCM: U653 5191020C51 U654 5191020C52 WL: U134 5191013H22 U135 5191013H21 EXC: U3701 5191012L73	SCM: B013.03.013 WL: B013.03.007 EXC: B013.03.006			
R4.00	R4.01	SCM: U653 5191022C13 U654 5191022C14 WL: U134 5191013H26 U135 5191013H25 EXC: U3701 5191012L75	SCM: B013.04.007 WL: B013.04.004 EXC: B013.04.004			
R5.00	R5.01	N/A	N/A	SZ2.7E	SCM: U653 5191022C11 U654 5191022C12 WL: U134 5191013H22 U135 5191013H21 EXC: U3701 5181012L73	IR: 11.69 WL: B013.03.007 EXC: B013.03.006

Notes:

1. There is no further development for these control boards
2. The firmware versions may be displayed by selecting Status Report from the Service menu. Exciter firmware version numbers (Conventional/6809 Trunking) are not displayed for RSS Releases R1.00 through R3.01. IR and Exciter firmware version numbers (IntelliRepeater/SmartZone) are not displayed.

**Table 7-2** TTN4094<sup>1</sup> and TRN7900<sup>1</sup> Station Control Boards RSS Compatibility

RSS Version Release	Conventional/6809 Trunking			IntelliRepeater/SMARTZONE		
	Release	IC/Part No.	Firmware Version <sup>2</sup>	Release	IC/Part No.	Firmware Version <sup>2</sup>
R5.00	R5.00	<b>SCM:</b> U651 5191020H09 U652 5191020H10 U653 5191020H11 U654 5191020H12 <b>WL:</b> U134 5191013H28 U135 5191013H27 <b>EXC:</b> U3701 5191012P13	<b>SCM:</b> B013.05.07 <b>WL:</b> B013.05.001 <b>EXC:</b> B013.05.02	SZ2.7	<b>SCM:</b> U653 5191022C11 U654 5191022C12 <b>WL:</b> U134 5191013H22 U135 5191013H21 <b>EXC: U3701 5181012L73</b>	<b>IR:</b> 11.69 <b>WL:</b> B013.03.007 <b>EXC:</b> B013.03.006
	R5.01	<b>SCM:</b> U651 5191020H13 U652 5191020H14 U653 5191020H15 U654 5191020H16 <b>WL:</b> U134 5191013H30 U135 5191013H29 <b>EXC:</b> U3701 5191012P13	<b>SCM:</b> B013.05.07 <b>WL:</b> B013.05.001 <b>EXC:</b> B013.05.02	SZ2.7E	<b>SCM:</b> U651 5191020H21 U652 5191020H22 U653 5191020H23 U654 5191020H24 <b>WL:</b> U134 5191013H28 U135 5191013H27 <b>EXC: U3701 5191012P13</b>	<b>IR:</b> 13.11 <b>WL:</b> B013.05.001 <b>EXC:</b> B013.05.002
R6.00	R6.00	<b>SCM:</b> U651 5191020L01 U652 5191020L02 U653 5191020L03 U654 5191020L04 <b>WL:</b> U134 5191013H66 U135 5191013H65 <b>EXC:</b> U3701 5191013P14	<b>SCM:</b> 15.06.009 <b>WL:</b> 15.06.004 <b>EXC:</b> 13.05.002	SZ2.0.3	<b>SCM:</b> U651 5191022C29 U652 5191022C30 U653 5191022C31 U654 5191022C32 <b>WL:</b> U134 5191022H66 U135 5191022H65 <b>EXC: U3701 5191013P13</b>	<b>IR:</b> 15.06.514 <b>WL:</b> 15.06.004 <b>EXC:</b> 13.05.002
	R6.01	<b>SCM:</b> U651 5191020L01 U652 5191020L02 U653 5191020L03 U654 5191020L04 <b>WL:</b> U134 5191013H68 U135 5191013H67 <b>EXC:</b> U3701 5191013P14	<b>SCM:</b> 15.06.009 <b>WL:</b> 15.06.011 <b>EXC:</b> 13.05.002	SZ2.0.3	<b>SCM:</b> U651 5191022C33 U652 5191022C34 U653 5191022C35 U654 5191022C36 <b>WL:</b> U134 5191013H68 U135 5191013H67 <b>EXC: U3701 5191013P13</b>	<b>IR:</b> 16.06.521 <b>WL:</b> 16.06.011 <b>EXC:</b> 13.05.002
	R6.02	<b>SCM:</b> U651 5191020L05 U652 5191020L06 U653 5191020L07 U654 5191020L08 <b>WL:</b> U134 5191013H70 U135 5191013H69 <b>EXC:</b> U3701 5191013P14	<b>SCM:</b> 16.06.018 <b>WL:</b> 16.06.013 <b>EXC:</b> 13.05.002	SZ2.0.3	<b>SCM:</b> U651 5191022C33 U652 5191022C34 U653 5191022C35 U654 5191022C36 <b>WL:</b> U134 5191013H70 U135 5191013H69 <b>EXC: U3701 5191013P13</b>	<b>IR:</b> 16.06.521 <b>WL:</b> 16.06.013 <b>EXC:</b> 13.05.002

**Table 7-2** TTN4094<sup>1</sup> and TRN7900<sup>1</sup> Station Control Boards RSS Compatibility (continued)

RSS Version Release	Conventional/6809 Trunking			IntelliRepeater/SMARTZONE		
	Release	IC/Part No.	Firmware Version <sup>2</sup>	Release	IC/Part No.	Firmware Version <sup>2</sup>
R7.00	R7.00	<b>SCM:</b> U651 5191020L13 U652 5191020L14 U653 5191020L15 U654 5191020L16 <b>WL:</b> U134 5191013H74 U135 5191013H73 <b>EXC:</b> U3701 5191012P14	<b>SCM:</b> 016.07.015 <b>WL:</b> 016.07.008 <b>EXC:</b> 16.06.001	SZ2.0.3	<b>SCM:</b> U651 5191022C33 U652 5191022C34 U653 5191022C35 U654 5191022C36 <b>WL:</b> U134 5191013H74 U135 5191013H73 <b>EXC:</b> U3701 5191012P14	<b>IR:</b> 16.06.521 <b>WL:</b> 16.07.008 <b>EXC:</b> 16.06.001
	R7.01	<b>SCM:</b> U651 5191020L17 U652 5191020L18 U653 5191020L19 U654 5191020L20 <b>WL:</b> U134 5191013H76 U135 5191013H75 <b>EXC:</b> U3701 5191012P14	<b>SCM:</b> 016.07.026 <b>WL:</b> 016.07.013 <b>EXC:</b> 016.06.001	SZ2.0.3	<b>SCM:</b> U651 5191022C33 U652 5191022C34 U653 5191022C35 U654 5191022C36 <b>WL:</b> U134 5191013H76 U135 5191013H75 <b>EXC:</b> U3701 5191012P14	<b>IR:</b> 16.06.521 <b>WL:</b> 16.07.013 <b>EXC:</b> 16.06.001
	R7.02	<b>SCM:</b> U651 5191020L21 U652 5191020L22 U653 5191020L23 U654 5191020L24 <b>WL:</b> U134 5191013H78 U135 5191013H77 <b>EXC:</b> U3701 5191012P14	<b>SCM:</b> 016.07.030 <b>WL:</b> 016.07.014 <b>EXC:</b> 016.06.001	SZ2.0.3	<b>SCM:</b> U651 5191022C33 U652 5191022C34 U653 5191022C35 U654 5191022C36 <b>WL:</b> U134 5191013H78 U135 5191013H77 <b>EXC:</b> U3701 5191012P14	<b>IR:</b> 16.06.521 <b>WL:</b> 16.07.014 <b>EXC:</b> 16.06.001

Table 7-2 TTN4094<sup>1</sup> and TRN7900<sup>1</sup> Station Control Boards RSS Compatibility (continued)

RSS Version Release	Conventional/6809 Trunking			IntelliRepeater/SMARTZONE		
	Release	IC/Part No.	Firmware Version <sup>2</sup>	Release	IC/Part No.	Firmware Version <sup>2</sup>
R07.02.02	R7.03	SCM: U651 5191020L25 U652 5191020L26 U653 5191020L27 U654 5191020L28 WL: U134 5191013H99 U135 5191013H98 EXC: U3701 5191012P14	SCM: 016.07.034 WL: 016.07.018 EXC: 016.07.001	SZ2.0.3	SCM: U651 5191022C33 U652 5191022C34 U653 5191022C35 U654 5191022C36 WL: U134 5191013H99 U135 5191013H98 EXC: U3701 5191012P14	IR: 16.06.521 WL: 16.07.018 EXC: 16.06.001
	R8.0			SZ2.0.3	SCM: U651 5191022C37 U652 5191022C38 U653 5191022C39 U654 5191022C41 WL: U134 5191013H99 U135 5191013H98 EXC: U3701 5191012P14	IR: 16.08.503 WL: 16.07.018 EXC: 16.06.001
	R8.1	SCM: U651 5191020L37 U652 5191020L38 U653 5191020L39 U654 5191020L40 WL: U134 5191013L28 U135 5191013L27 EXC: U3701 5191012P14	SCM: 016.08.004 WL: 016.08.002 EXC: 016.07.001	SZ2.0.3	SCM: U651 5191022C46 U652 5191022C47 U653 5191022C48 U654 5191022C49 WL: U134 5191013L28 U135 5191013L27 EXC: U3701 5191012P14	IR: 16.08.508 WL: 16.08.002 EXC: 16.06.001
	R8.2	SCM: U651 5191020L88 U652 5191020L89 U653 5191020L90 U654 5191020L91 WL: U134 5191013L28 U135 5191013L27 EXC: U3701 5191012P14	SCM: 016.08.006 WL: 016.08.002 EXC: 016.07.001			
	R8.3	SCM: U651 PC5091104000008008 U652 PC5091204000008008 U653 PC5091304000008008 U654 PC5091404000008008 WL: U134 PC5095104000008003 U135 PC5095204000008003 EXC: U3701 5191012P14	SCM: 016.08.008 WL: 016.08.003 EXC: 016.07.001	SZ2.0.3	SCM: U651 5191022C46 U652 5191022C47 U653 5191022C48 U654 5191022C49 WL: U134 PC5095104000008003 U135 PC5095204000008003 EXC: U3701 5191012P14	IR: 16.08.508 WL: 16.08.003 EXC: 16.06.001
	R8.5	SCM: U651 PC5091104000008010 U652 PC5091204000008010 U653 PC5091304000008010 U654 PC5091404000008010 WL: U134 PC5095104000008003 U135 PC5095204000008003 EXC: U3701 5191012P14	SCM: 016.08.010 WL: 016.08.003 EXC: 016.07.001	SZ2.0.3	SCM: U651 PC5091104000008511 U652 PC5091204000008511 U653 PC5091304000008511 U654 PC5091404000008511 WL: U134 PC5095104000008003 U135 PC5095204000008003 EXC: U3701 5191012P14	IR: 16.08.511 WL: 16.08.003 EXC: 16.06.001

## Notes:

1. No further development for these control boards
2. The firmware versions may be displayed by selecting Status Report from the Service menu. IR and Exciter firmware version numbers (IntelliRepeater/SMARTZONE) are not displayed.

**Table 7-3** CLN6960, CLN6961, CLN6873, and CLN7060 Station Control Boards (with Software Download Capability; Non-IntelliRepeater 5.0 Stations) RSS Compatibility

RSS Version Release	Conventional/6809 Trunking			IntelliRepeater/SMARTZONE		
	Release	Software/IC Part Numbers	Software Version <sup>1</sup>	Release	Software/IC Part Numbers	Software Version <sup>1</sup>
	R9.00	<b>SCM:</b> P651 SIMM 0180706F52 App Sftwr PC5091103000009017 Boot2 PC5091002000009012 <b>WL:</b> U134 PC5095201000009008 U135 PC5095101000009008 App Sftwr PC5095103000009015 <b>EXC:</b> PC5093104000009001	<b>SCM:</b> SC_020_09_017 <b>WL:</b> WL_020_09_015 Boot: B2_020_09_012 <b>EXC:</b> 020.09.001	SZ3.0	<b>SCM:</b> P651 SIMM 0180706F51 App Sftwr PC5091103000009519 Boot2 PC5091002000009012 <b>WL:</b> U134 PC5095201000009008 U135 PC5095101000009008 App Sftwr PC5095103000009015 <b>EXC:</b> PC5093104000009001	<b>SCM:</b> IR_020_09_519 <b>WL:</b> WL_020_09_015 Boot: B2_020_09_012 <b>EXC:</b> 020.09.001
R09.00.00	R9.01	<b>SCM:</b> P651 SIMM 0180706F52 App Sftwr PC5091103000009028 Boot2 PC5091002000009012 <b>WL:</b> U134 PC5095201000009008 U135 PC5095101000009008 App Sftwr PC5095103000009022 <b>EXC:</b> PC5093104000009001	<b>SCM:</b> SC_020_09_028 <b>WL:</b> WL_020_09_022 Boot: B2_020_09_012 <b>EXC:</b> 020.09.001	SZ3.0	<b>SCM:</b> P651 SIMM 0180706F51 App Sftwr PC5091103000009528 Boot2 PC5091002000009012 <b>WL:</b> U134 PC5095201000009008 U135 PC5095101000009008 App Sftwr PC5095103000009022 <b>EXC:</b> PC5093104000009001	<b>SCM:</b> IR_020_09_528 <b>WL:</b> WL_020_09_022 Boot: B2_020_09_012 <b>EXC:</b> 020.09.001
R09.02.01	R9.02	<b>SCM:</b> P651 SIMM 0180706F52 App Sftwr PC5091103000009031 Boot2 PC5091002000009014 <b>WL:</b> U134 PC5095201000009008 U135 PC5095101000009008 App Sftwr PC5095103000009022 <b>EXC:</b> PC5093104000009001	<b>SCM:</b> SC_020_09_031 <b>WL:</b> WL_020_09_022 Boot: B2_020_09_014 <b>EXC:</b> 020.09.001	SZ2.0.3 <sup>2</sup> and SZ3.0	<b>SCM:</b> P651 SIMM 0180706F51 App Sftwr PC5091103000009533 Boot2 PC5091002000009014 <b>WL:</b> U134 PC5095201000009008 U135 PC5095101000009008 App Sftwr PC5095103000009022 <b>EXC:</b> PC5093104000009001	<b>SCM:</b> IR_020_09_533 <b>WL:</b> WL_020_09_022 Boot: B2_020_09_014 <b>EXC:</b> 020.09.001
R09.03.00	R9.03	<b>SCM:</b> P651 SIMM 0180706F52 App Sftwr PC5091103000009042 Boot2 PC5091002000009016 <b>WL:</b> U134 PC5095201000009008 U135 PC5095101000009008 App Sftwr PC5095101000009028 <b>EXC:</b> PC5093104000009001	<b>SCM:</b> SC_020_09_042 <b>WL:</b> WL_020_09_028 Boot: B2_020_09_016 <b>EXC:</b> 020.09.001		<b>SCM:</b> P651 SIMM 0180706F51 App Sftwr PC5091103000009542 Boot2 PC5091002000009016 <b>WL:</b> U134 PC5095201000009008 U135 PC5095101000009008 App Sftwr PC5095101000009028 <b>EXC:</b> PC5093104000009001	<b>SCM:</b> IR_020_09_542 <b>WL:</b> WL_020_09_028 Boot: B2_020_09_016 <b>EXC:</b> 020.09.001
	R9.04	<b>SCM:</b> P651 SIMM 0180706F52 App Sftwr PC5091103000009044 Boot2 PC5091002000009016 <b>WL:</b> U134 PC5095201000009008 U135 PC5095101000009008 App Sftwr PC5095101000009028 <b>EXC:</b> PC5093104000009003	<b>SCM:</b> SC_020_09_044 <b>WL:</b> WL_020_09_028 Boot: B2_020_09_016 <b>EXC:</b> 020.09.003		<b>SCM:</b> P651 SIMM 0180706F51 App Sftwr PC5091103000009544 Boot2 PC5091002000009016 <b>WL:</b> U134 PC5095201000009008 U135 PC5095101000009008 App Sftwr PC5095101000009028 <b>EXC:</b> PC5093104000009003	<b>SCM:</b> IR_020_09_544 <b>WL:</b> WL_020_09_028 Boot: B2_020_09_016 <b>EXC:</b> 020.09.003
	R9.04.03	<b>SCM:</b> P651 SIMM 0180706F52 App Sftwr PC5091103000009021 Boot2 PC5091002000009012 <b>WL:</b> U134 PC5095201000009008 U135 PC5095101000009008 App Sftwr PC5095101000009028 <b>EXC:</b> PC5093104000009003	<b>SCM:</b> SC_020_09_044 <b>WL:</b> WL_020_09_028 Boot: B2_020_09_021 <b>EXC:</b> 020.09.003		<b>SCM:</b> P651 SIMM 0180706F51 App Sftwr PC5091103000009544 Boot2 PC5091002000009021 <b>WL:</b> U134: PC5095201000009008 U135: PC5095101000009008 App Sftwr: PC5095101000009028 <b>EXC:</b> PC5093104000009003	<b>SCM:</b> IR_020_09_544 <b>WL:</b> WL_020_09_028 Boot: B2_020_09_021 <b>EXC:</b> 020.09.003

**Table 7-3** CLN6960, CLN6961, CLN6873, and CLN7060 Station Control Boards (with Software Download Capability; Non-IntelliRepeater 5.0 Stations) RSS Compatibility (continued)

RSS Version Release	Conventional/6809 Trunking			IntelliRepeater/SMARTZONE		
	Release	Software/IC Part Numbers	Software Version <sup>1</sup>	Release	Software/IC Part Numbers	Software Version <sup>1</sup>
R09.05.00	R9.05	<b>SCM:</b> P651 SIMM 0180706F52 App Sftwr PC509110300009055 Boot2 PC5091002000009022 <b>WL:</b> U134 PC5095201000009008 U135 PC5095101000009008 App Sftwr PC509500100009033 <b>EXC:</b> PC5093104000009004	<b>SCM:</b> SC_020_09_055 <b>WL:</b> WL_020_09_033 Boot: B2_020_09_022 <b>EXC:</b> 020.09.004	SZ2.0.3 <sup>2</sup> and SZ3.0	<b>SCM:</b> P651 SIMM 0180706F51 App Sftwr PC509110300009552 Boot2 PC5091002000009022 <b>WL:</b> U134 PC5095201000009008 U135 PC5095101000009008 App Sftwr PC509500100009033 <b>EXC:</b> PC5093104000009004	<b>SCM:</b> IR_020_09_552 <b>WL:</b> WL_020_09_033 Boot: B2_020_09_022 <b>EXC:</b> 020.09.004
R09.06.00	R9.06	<b>SCM:</b> P651 SIMM 0180706F52 App Sftwr PC509110300009062 Boot2 PC5091002000009025 <b>WL:</b> U134 PC5095201000009008 U135 PC5095101000009008 App Sftwr PC509500100009034 <b>EXC:</b> PC5093104000009004	<b>SCM:</b> SC_020_09_062 <b>WL:</b> WL_020_09_034 Boot: B2_020_09_025 <b>EXC:</b> 020.09.004		<b>SCM:</b> P651 SIMM 0180706F51 App Sftwr PC509110300009558 Boot2 PC5091002000009025 <b>WL:</b> U134 PC5095201000009008 U135 PC5095101000009008 App Sftwr PC509500100009034 <b>EXC:</b> PC5093104000009004	<b>SCM:</b> IR_020_09_558 <b>WL:</b> WL_020_09_034 Boot: B2_020_09_025 <b>EXC:</b> 020.09.004
R09.07.00	R9.07	<b>SCM:</b> P651 SIMM 0180706F52 App Sftwr PC509F10300009068 Boot2 PC5091002000009026 <b>WL:</b> U134 PC5095201000009008 U135 PC5095101000009008 App Sftwr PC509500100009036 <b>EXC:</b> PC5093104000009005	<b>SCM:</b> SC_020_09_068 <b>WL:</b> WL_020_09_036 Boot: B2_020_09_026 <b>EXC:</b> 020.09.005	<b>SCM:</b> P651 SIMM 0180706F51 App Sftwr PC509F10400009564 Boot2 PC5091002000009026 <b>WL:</b> U134 PC5095201000009008 U135 PC5095101000009008 App Sftwr PC509500100009036 <b>EXC:</b> PC5093104000009005	<b>SCM:</b> IR_020_09_564 <b>WL:</b> WL_020_09_036 Boot: B2_020_09_026 <b>EXC:</b> 020.09.005	
R10.00.00	R10.00	<b>SCM:</b> P651 SIMM 0180706F52 App Sftwr PC509F10300010002 Boot2 PC5091002000010001 <b>WL:</b> U134 PC5095204000009813 U135 PC5095104000009813 App Sftwr PC509500100010001 <b>EXC:</b> PC5093104000009005	<b>SCM:</b> SC_020_10_006 <b>WL:</b> WL_020_10_001 Boot: B2_020_10_001 <b>EXC:</b> 020.09.005	<b>SCM:</b> P651 SIMM 0180706F51 App Sftwr PC509F10400010502 Boot2 PC5091002000010001 <b>WL:</b> U134 PC5095204000009813 U135 PC5095104000009813 App Sftwr PC509500100010001 <b>EXC:</b> PC5093104000009005	<b>SCM:</b> IR_020_10_506 <b>WL:</b> WL_020_10_001 Boot: B2_020_10_001 <b>EXC:</b> 020.09.005	
R10.01.00	R10.01	<b>SCM:</b> P651 SIMM 0180706F52 App Sftwr PC509F10300010013 Boot2 PC5091002000010001 <b>WL:</b> U134 PC5095204000009813 U135 PC5095104000009813 App Sftwr PC509500100010001 <b>EXC:</b> PC5093104000009005	<b>SCM:</b> SC_020_10_013 <b>WL:</b> WL_020_10_001 Boot: B2_020_10_001 <b>EXC:</b> 020.09.005	<b>SCM:</b> P651 SIMM 0180706F51 App Sftwr PC509F10400010513 Boot2 PC5091002000010001 <b>WL:</b> U134 PC5095204000009813 U135 PC5095104000009813 App Sftwr PC509500100010001 <b>EXC:</b> PC5093104000009005	<b>SCM:</b> IR_020_10_513 <b>WL:</b> WL_020_10_001 Boot: B2_020_10_001 <b>EXC:</b> 020.09.005	
R10.02.00	R10.02	<b>SCM:</b> P651 SIMM 0180706F52 App Sftwr PC509F10300010021 Boot2 PC5091002000010001 <b>WL:</b> U134 PC5095204000010806 U135 PC5095104000010806 App Sftwr PC509500100010007 <b>EXC:</b> PC5093104000009005	<b>SCM:</b> SC_020_10_021 <b>WL:</b> WL_020_10_007 Boot: B2_020_10_001 <b>EXC:</b> 020.09.005	<b>SCM:</b> P651 SIMM 0180706F51 App Sftwr PC509F10400010520 Boot2: PC5091002000010001 <b>WL:</b> U134 PC5095204000010806 U135 PC5095104000010806 App Sftwr PC509500100010007 <b>EXC:</b> PC5093104000009005	<b>SCM:</b> IR_020_10_520 <b>WL:</b> WL_020_10_007 Boot: B2_020_10_001 <b>EXC:</b> 020.09.005	
R10.03.00	R10.03	<b>SCM:</b> P651 SIMM 0180706F52 App Sftwr PC509F10300010030 Boot2 PC5091002000010002 <b>WL:</b> U134 PC5095204000010807 U135 PC5095104000010807 App Sftwr PC509500100010008 <b>EXC:</b> PC5093104000009005	<b>SCM:</b> SC_020_10_030 <b>WL:</b> WL_020_10_008 Boot: B2_020_10_002 <b>EXC:</b> 020.09.005	SZ2.0.3 <sup>2</sup> and SZ3.0	<b>SCM:</b> P651 SIMM 0180706F51 App Sftwr PC509F10400010527 Boot2 PC5091002000010002 <b>WL:</b> U134 PC5095204000010807 U135 PC5095104000010807 App Sftwr PC509500100010008 <b>EXC:</b> PC5093104000009005	<b>SCM:</b> IR_020_10_527 <b>WL:</b> WL_020_10_008 Boot: B2_020_10_002 <b>EXC:</b> 020.09.005
R10.04.00	R10.04	<b>SCM:</b> P651 SIMM 0180706F52 App Sftwr PC509F10300010042 Boot2 PC5091002000010003 <b>WL:</b> U134 PC5095204000010807 U135 PC5095104000010807 App Sftwr PC509500100010008 <b>EXC:</b> PC5093104000009005	<b>SCM:</b> SC_020_10_042 <b>WL:</b> WL_020_10_008 Boot: B2_020_10_003 <b>EXC:</b> 020.09.005		<b>SCM:</b> P651 SIMM 0180706F51 App Sftwr PC509F10400010536 Boot2 PC5091002000010003 <b>WL:</b> U134 PC5095204000010807 U135 PC5095104000010807 App Sftwr PC509500100010008 <b>EXC:</b> PC5093104000009005	<b>SCM:</b> IR_020_10_536 <b>WL:</b> WL_020_10_008 Boot: B2_020_10_003 <b>EXC:</b> 020.09.005

**Table 7-3** CLN6960, CLN6961, CLN6873, and CLN7060 Station Control Boards (with Software Download Capability; Non-IntelliRepeater 5.0 Stations) RSS Compatibility (continued)

RSS Version Release	Conventional/6809 Trunking			IntelliRepeater/SMARTZONE		
	Release	Software/IC Part Numbers	Software Version <sup>1</sup>	Release	Software/IC Part Numbers	Software Version <sup>1</sup>
R10.05.00	R10.05	<b>SCM:</b> P651 SIMM 0180706F52 App Sftwr PC509F10300010049 Boot2 PC5091002000010008 <b>WL:</b> U134 PC5095204000010812 U135 PC5095104000010812 App Sftwr PC509500100010014 <b>EXC:</b> PC5093104000009005	<b>SCM:</b> SC_020_10_049 <b>WL:</b> WL_020_10_014 Boot: B2_020_10_008 <b>EXC:</b> 020.09.005	SZ2.0.3 <sup>2</sup> and SZ3.0	<b>SCM:</b> P651 SIMM 0180706F51 App Sftwr PC509F10400010543 Boot2 PC5091002000010008 <b>WL:</b> U134 PC5095204000010812 U135 PC5095104000010812 App Sftwr PC509500100010014 <b>EXC:</b> PC5093104000009005	<b>SCM:</b> IR_020_10_543 <b>WL:</b> WL_020_10_014 Boot: B2_020_10_008 <b>EXC:</b> 020.09.005
R10.06.00	R10.06	<b>SCM:</b> P651 SIMM 0180706F52 App Sftwr PC509F10300010058 Boot2 PC5091002000010012 <b>WL:</b> U134 PC5095204000010816 U135 PC5095104000010816 App Sftwr PC509500100010018 <b>EXC:</b> PC5093104000009005	<b>SCM:</b> SC_020_10_058 <b>WL:</b> WL_020_10_018 Boot: B2_020_10_012 <b>EXC:</b> 020.09.005	SZ3.0	<b>SCM:</b> P651 SIMM 0180706F51 App Sftwr PC509F10400010552 Boot2 PC5091002000010012 <b>WL:</b> U134 PC5095204000010816 U135 PC5095104000010816 App Sftwr PC509500100010018 <b>EXC:</b> PC5093104000009005	<b>SCM:</b> IR_020_10_552 <b>WL:</b> WL_020_10_018 Boot: B2_020_10_012 <b>EXC:</b> 020.09.005
	R10.07	<b>SCM:</b> P651 SIMM 0180706F52 App Sftwr PC509F10300010066 Boot2 PC5091002000010016 <b>WL:</b> U134 PC5095204000010816 U135 PC5095104000010816 App Sftwr PC509500100010021 <b>EXC:</b> PC5093104000009005	<b>SCM:</b> SC_020_10_066 <b>WL:</b> WL_020_10_021 Boot: B2_020_10_016 <b>EXC:</b> 020.09.005	SZ3.0	<b>SCM:</b> P651 SIMM 0180706F51 App Sftwr PC509F10400010560 Boot2 PC5091002000010016 <b>WL:</b> U134 PC5095204000010816 U135 PC5095104000010816 App Sftwr PC509500100010021 <b>EXC:</b> PC5093104000009005	<b>SCM:</b> IR_020_10_560 <b>WL:</b> WL_020_10_021 Boot: B2_020_10_016 <b>EXC:</b> 020.09.005
R10.07.00	R10.08	<b>SCM:</b> P651 SIMM 0180706F52 App Sftwr PC509F10300010066 Boot2 PC5091002000010016 <b>WL:</b> U134 PC5095204000010816 U135 PC5095104000010816 App Sftwr PC509500100010021 <b>EXC:</b> PC5093104000009005	<b>SCM:</b> SC_020_10_066 <b>WL:</b> WL_020_10_021 Boot: B2_020_10_016 <b>EXC:</b> 020.09.005	SZ3.0	<b>SCM:</b> P651 SIMM 0180706F51 App Sftwr PC509F10400010565 Boot2 PC5091002000010016 <b>WL:</b> U134 PC5095204000010816 U135 PC5095104000010816 App Sftwr PC509500100010021 <b>EXC:</b> PC5093104000009005	<b>SCM:</b> IR_020_10_565 <b>WL:</b> WL_020_10_021 Boot: B2_020_10_016 <b>EXC:</b> 020.09.005
	R10.09	<b>SCM:</b> P651 SIMM 0180706F52 App Sftwr PC509F10300010080 Boot2 PC5091002000010016 <b>WL:</b> U134 PC5095204000010816 U135 PC5095104000010816 App Sftwr PC509500100010021 <b>EXC:</b> PC5093104000009005	<b>SCM:</b> SC_020_10_080 <b>WL:</b> WL_020_10_021 Boot: B2_020_10_016 <b>EXC:</b> 020.09.005	SZ3.0	<b>SCM:</b> P651 SIMM 0180706F51 App Sftwr PC509F10400010578 Boot2 PC5091002000010016 <b>WL:</b> U134 PC5095204000010816 U135 PC5095104000010816 App Sftwr PC509500100010021 <b>EXC:</b> PC5093104000009005	<b>SCM:</b> IR_020_10_578 <b>WL:</b> WL_020_10_021 Boot: B2_020_10_016 <b>EXC:</b> 020.09.005
R10.08.00	R10.10	<b>SCM:</b> P651 SIMM 0180706F52 App Sftwr PC509F10300010086 Boot2 PC5091002000010019 <b>WL:</b> U134 PC5095204000010816 U135 PC5095104000010816 App Sftwr PC509500100010021 <b>EXC:</b> PC5093104000009005	<b>SCM:</b> SC_020_10_086 <b>WL:</b> WL_020_10_021 Boot: B2_020_10_019 <b>EXC:</b> 020.09.005	SZ3.0	<b>SCM:</b> P651 SIMM 0180706F51 App Sftwr PC509F104000010584 Boot2 PC5091002000010019 <b>WL:</b> U134 PC5095204000010816 U135 PC5095104000010816 App Sftwr PC509500100010021 <b>EXC:</b> PC5093104000009005	<b>SCM:</b> IR_020_10_584 <b>WL:</b> WL_020_10_021 Boot: B2_020_10_019 <b>EXC:</b> 020.09.005
R10.11.00	R10.11	<b>SCM:</b> P651 SIMM 0180706F52 App Sftwr PC509F10300010095 Boot2 PC5091002000010022 <b>WL:</b> U134 PC5095204000010816 U135 PC5095104000010816 App Sftwr PC509500100010025 <b>EXC:</b> PC5093104000009005	<b>SCM:</b> SC_020_10_095 <b>WL:</b> WL_020_10_025 Boot: B2_020_10_022 <b>EXC:</b> 020.09.005	SZ3.0	<b>SCM:</b> P651 SIMM 0180706F51 App Sftwr PC509F104000010593 Boot2 PC5091002000010022 <b>WL:</b> U134 PC5095204000010816 U135 PC5095104000010816 App Sftwr PC509500100010025 <b>EXC:</b> PC5093104000009005	<b>SCM:</b> IR_020_10_593 <b>WL:</b> WL_020_10_025 Boot: B2_020_10_022 <b>EXC:</b> 020.09.005
R10.12.00	R10.12	<b>SCM:</b> P651 SIMM 0180706F52 App Sftwr PC509F10300010101 Boot2 PC5091002000010022 <b>WL:</b> U134 PC5095204000010816 U135 PC5095104000010816 App Sftwr PC509500100010025 <b>EXC:</b> PC5093104000009005	<b>SCM:</b> SC_020_10_101 <b>WL:</b> WL_020_10_025 Boot: B2_020_10_022 <b>EXC:</b> 020.09.005	SZ3.0	<b>SCM:</b> P651 SIMM 0180706F51 App Sftwr PC509F104000010599 Boot2 PC5091002000010022 <b>WL:</b> U134 PC5095204000010816 U135 PC5095104000010816 App Sftwr PC509500100010025 <b>EXC:</b> PC5093104000009005	<b>SCM:</b> IR_020_10_599 <b>WL:</b> L_020_10_025 Boot: B2_020_10_022 <b>EXC:</b> 020.09.005

**Table 7-3** CLN6960, CLN6961, CLN6873, and CLN7060 Station Control Boards (with Software Download Capability; Non-IntelliRepeater 5.0 Stations) RSS Compatibility (continued)

RSS Version Release	Conventional/6809 Trunking			IntelliRepeater/SMARTZONE		
	Release	Software/IC Part Numbers	Software Version <sup>1</sup>	Release	Software/IC Part Numbers	Software Version <sup>1</sup>
R10.12.00	R10.13	<b>SCM:</b> P651 SIMM 0180706F52 App Sftwr PC509F10300010101 Boot2 PC5091002000010022 <b>WL:</b> U134 PC5095204000010816 U135 PC5095104000010816 App Sftwr PC509500100010025 <b>EXC:</b> PC5093104000009005	<b>SCM:</b> SC_020_10_101 <b>WL:</b> WL_020_10_025 Boot: B2_020_10_022 <b>EXC:</b> 020.09.005	SZ3.0	<b>SCM:</b> P651 SIMM 0180706F51 App Sftwr PC509F104000010599 Boot2 PC5091002000010022 <b>WL:</b> U134 PC5095204000010816 U135 PC5095104000010816 App Sftwr PC509500100010025 <b>EXC:</b> PC5093104000009005	<b>SCM:</b> IR_020_10_599 <b>WL:</b> WL_020_10_025 Boot: B2_020_10_022 <b>EXC:</b> 020.09.005
R12.01.00	R12.01	<b>SCM:</b> P651 SIMM 0180706F52 App Sftwr PC509F10300012008 Boot2 PC5091002000010022 <b>WL:</b> U134 PC5095204000010816 U135 PC5095104000010816 App Sftwr PC509500100012003 <b>EXC:</b> PC5093104000009009	<b>SCM:</b> SC_020_12_008 <b>WL:</b> WL_020_12_003 Boot: B2_020_10_022 <b>EXC:</b> 020.09.009	SZ3.0 and SZ4.1	<b>SCM:</b> P651 SIMM 0180706F51 App Sftwr PC509F104000012508 Boot2 PC5091002000010022 <b>WL:</b> U134 PC5095204000010816 U135 PC5095104000010816 App Sftwr PC509500100012003 <b>EXC:</b> PC5093104000009009	<b>SCM:</b> IR_020_12_508 <b>WL:</b> WL_020_12_003 Boot: B2_020_10_022 <b>EXC:</b> 020.09.009
R12.02.00	R12.02	<b>SCM:</b> P651 SIMM 0180706F52 App Sftwr PC509F10300012021 Boot2 PC5091002000010022 <b>WL:</b> U134 PC5095204000010816 U135 PC5095104000010816 App Sftwr PC509F02N000012004 <b>EXC:</b> PC509E02M000009010	<b>SCM:</b> SC_020_12_021 <b>WL:</b> WL_020_12_004 Boot: B2_020_10_022 <b>EXC:</b> 020.09.010	SZ3.0 and SZ4.1	<b>SCM:</b> P651 SIMM 0180706F51 App Sftwr PC509F104000012508 Boot2 PC509F104000010022 App Sftwr PC509F02N000012004 <b>EXC:</b> PC509E02M000009010	<b>SCM:</b> IR_020_12_521 <b>WL:</b> WL_020_12_004 Boot: B2_020_10_022 <b>EXC:</b> 020.09.010
R12.03.00	R12.03	<b>SCM:</b> P651 SIMM 0180706F52 App Sftwr PC509F10300012024 Boot2 PC5091002000010022 <b>WL:</b> U134 PC5095204000010816 U135 PC5095104000010816 App Sftwr PC509F02N000012008 <b>EXC:</b> PC509E02M000009017	<b>SCM:</b> SC_020_12_024 <b>WL:</b> WL_020_12_008 Boot: B2_020_10_022 <b>EXC:</b> 020.09.017	SZ3.0 and SZ4.1	<b>SCM:</b> P651 SIMM 0180706F51 App Sftwr PC509F104000012524 Boot2 PC509F104000010022 App Sftwr PC509F02N000012008 <b>EXC:</b> PC509E02M000009017	SCML: IR_020_12_524 <b>WL:</b> WL_020_12_008 Boot: B2_020_10_022 <b>EXC:</b> 020.09.017
R12.04.00	R12.04	<b>SCM:</b> P651 SIMM 0180706F52 App Sftwr PC509F10300012034 Boot2 PC5091002000010022 <b>WL:</b> U134 PC5095204000010816 U135 PC5095104000010816 App Sftwr PC509F02N000012008 <b>EXC:</b> PC509E02M000009017	<b>SCM:</b> SC_020_12_034 <b>WL:</b> WL_020_12_008 Boot: B2_020_10_022 <b>EXC:</b> 020.09.017	SZ3.0 and SZ4.1	<b>SCM:</b> P651 SIMM 0180706F51 App Sftwr PC509F104000012524 Boot2 PC509F104000010022 App Sftwr PC509F02N000012008 <b>EXC:</b> PC509E02M000009017	SCML: IR_020_12_524 <b>WL:</b> WL_020_12_008 Boot: B2_020_10_022 <b>EXC:</b> 020.09.017
R12.05.00	R12.05	<b>SCM:</b> P651 SIMM 0180706F52 App Sftwr PC509F10300012034 Boot2 PC5091002000010022 <b>WL:</b> U134 PC5095204000010816 U135 PC5095104000010816 App Sftwr PC509F02N000012008 <b>EXC:</b> PC509E02M000009017	<b>SCM:</b> SC_020_12_034 <b>WL:</b> WL_020_12_008 Boot: B2_020_10_022 <b>EXC:</b> 020.09.017	SZ3.0 and SZ4.1	<b>SCM:</b> P651 SIMM 0180706F51 App Sftwr PC509F104000012529 Boot2 PC509F104000010022 App Sftwr PC509F02N000012008 <b>EXC:</b> PC509E02M000009017	SCML: IR_020_12_529 <b>WL:</b> WL_020_12_008 Boot: B2_020_10_022 <b>EXC:</b> 020.09.017
R12.06.00	R12.06	<b>SCM:</b> P651 SIMM 0180706F52 App Sftwr PC509F10300012047 Boot2 PC5091002000010022 <b>WL:</b> U134 PC5095204000010816 U135 PC5095104000010816 App Sftwr PC509F02N000012011 <b>EXC:</b> PC509E02M000009017	<b>SCM:</b> SC_020_12_047 <b>WL:</b> WL_020_12_011 Boot: B2_020_10_022 <b>EXC:</b> 020.09.017	SZ3.0 and SZ4.1	<b>SCM:</b> P651 SIMM 0180706F51 App Sftwr PC509F104000012535 Boot2 PC509F104000010022 App Sftwr PC509F02N000012011 <b>EXC:</b> PC509E02M000009017	SCML: IR_020_12_535 <b>WL:</b> WL_020_12_011 Boot: B2_020_10_022 <b>EXC:</b> 020.09.017
R12.07.00	R12.07	<b>SCM:</b> P651 SIMM 0180706F52 App Sftwr PC509F10300012071 Boot2 PC5091002000012006 <b>WL:</b> U134 PC5095204000010816 U135 PC5095104000010816 App Sftwr PC509F02N000012028 <b>EXC:</b> PC509E02M000009017	<b>SCM:</b> SC_020_12_071 <b>WL:</b> WL_020_12_028 Boot: B2_020_12_006 <b>EXC:</b> 020.09.017	SZ3.0 and SZ4.1	<b>SCM:</b> P651 SIMM 0180706F51 App Sftwr PC509F104000012541 Boot2 PC509F104000010022 App Sftwr PC509F02N000012011 <b>EXC:</b> PC509E02M000009017	SCML: IR_020_12_541 <b>WL:</b> WL_020_12_011 Boot: B2_020_10_022 <b>EXC:</b> 020.09.017



**Table 7-3** CLN6960, CLN6961, CLN6873, and CLN7060 Station Control Boards (with Software Download Capability; Non-IntelliRepeater 5.0 Stations) RSS Compatibility (continued)

RSS Version Release	Conventional/6809 Trunking			IntelliRepeater/SMARTZONE		
	Release	Software/IC Part Numbers	Software Version <sup>1</sup>	Release	Software/IC Part Numbers	Software Version <sup>1</sup>
R13.00.00	R13.00	<b>SCM:</b> P651 SIMM 0180706F52 App Sftwr PC509F10300013009 Boot2 PC5091002000010022 App Sftwr PC509F02N000012014 <b>EXC:</b> PC509E02M000009017	<b>SCM:</b> SC_020_13_009 <b>WL:</b> WL_020_12_014 Boot: B2_020_10_022 <b>EXC:</b> 020.09.017	SZ3.0 and SZ4.1	<b>SCM:</b> P651 SIMM 0180706F51 App Sftwr PC509F104000012541 Boot2 PC509F104000010022 App Sftwr PC509F02N000012014 <b>EXC:</b> PC509E02M000009017	SCML: IR_020_12_541 <b>WL:</b> WL_020_12_014 Boot: B2_020_10_022 <b>EXC:</b> 020.09.017
R13.01.00	R13.01	<b>SCM:</b> P651 SIMM 0180706F52 App Sftwr PC509F10300013017 Boot2 PC5091002000013001 App Sftwr PC509F02N000013002 <b>EXC:</b> PC509E02M000009017	<b>SCM:</b> SC_020_13_017 <b>WL:</b> WL_020_13_002 Boot: B2_020_13_001 <b>EXC:</b> 020.09.017	SZ3.0 and SZ4.1	<b>SCM:</b> P651 SIMM 0180706F51 App Sftwr PC509F104000012551 Boot2 PC509F104000013001 App Sftwr PC509F02N000013002 <b>EXC:</b> PC509E02M000009017	SCML: IR_020_12_551 <b>WL:</b> WL_020_13_002 Boot: B2_020_13_001 <b>EXC:</b> 020.09.017
R13.02.00	R13.02	<b>SCM:</b> P651 SIMM 0180706F52 App Sftwr PC509F10300013022 Boot2 PC5091002000013001 App Sftwr PC509F02N000013002 <b>EXC:</b> PC509E02M000009017	<b>SCM:</b> SC_020_13_022 <b>WL:</b> WL_020_13_002 Boot: B2_020_13_001 <b>EXC:</b> 020.09.017	SZ3.0 and SZ4.1	<b>SCM:</b> P651 SIMM 0180706F51 App Sftwr PC509F104000012551 Boot2 PC509F104000013001 App Sftwr PC509F02N000013002 <b>EXC:</b> PC509E02M000009017	SCML: IR_020_12_551 <b>WL:</b> WL_020_13_002 Boot: B2_020_13_001 <b>EXC:</b> 020.09.017
R14.00.00	R14.00	<b>SCM:</b> P651 SIMM 0180706F52 App Sftwr PC509F103000140xx Boot2 PC5091002000014001 App Sftwr PC509F02N000014000 <b>EXC:</b> PC509E02M000009017	<b>SCM:</b> SC_020_14_0xx <b>WL:</b> WL_020_14_0xx Boot: B2_020_14_001 <b>EXC:</b> 020.09.017	SZ3.0 and SZ4.1	<b>SCM:</b> P651 SIMM 0180706F51 App Sftwr PC509F1040000145xx Boot2 PC509F104000014001 App Sftwr PC509F02N000014501 <b>EXC:</b> PC509E02M000009017	SCML: IR_020_14_501 <b>WL:</b> WL_020_14_001 Boot: B2_020_14_001 <b>EXC:</b> 020.09.017

Notes:

1. The software versions may be displayed by selecting *Status Report* from the *Service* menu, or by selecting *Status Panel/Software Version/Set Date and Time* from the *Service* menu.
2. Stations in systems running SZ2.0.3 are not software download capable.

**Table 7-4** Factory Shipped Upgrade Kit<sup>1</sup> RSS Compatibility (for stations without Software Download Capability)

RSS Version Release	Conventional/6809 Trunking			IntelliRepeater/SMARTZONE		
	Release	Software/IC Part Numbers	Software Version (Note 1)	Release	Software/IC Part Numbers	Software Version (Note 1)
R09.02.01	R9.02	<b>SCM:</b> P651 SIMM 0180706F47 App Sftwr PC5091103000009031 Boot2 PC5091002000009014 <b>WL:</b> U134 PC5095204000009805 U135 PC5095104000009805 <b>EXC:</b> PC5093104000009001	<b>SCM:</b> SC_020_09_031 <b>WL:</b> WL_020_09_805 Boot: B2_020_09_014 <b>EXC:</b> 020.09.001	SZ2.03 <sup>2</sup>	<b>SCM:</b> P651 SIMM 0180706F50 App Sftwr PC5091103000009533 Boot2 PC5091002000009014 <b>WL:</b> U134 PC5095204000009805 U135 PC5095104000009805 <b>EXC:</b> PC5093104000009001	<b>SCM:</b> IR_020_09_533 <b>WL:</b> WL_020_09_805 Boot: B2_020_09_014 <b>EXC:</b> 020.09.001
R09.03.00	R9.03	<b>SCM:</b> P651 SIMM 0180706F47 App Sftwr PC5091103000009042 Boot2 PC5091002000009016 <b>WL:</b> U134 PC5095204000009809 U135 PC5095104000009809 <b>EXC:</b> PC5093104000009001	<b>SCM:</b> SC_020_09_042 <b>WL:</b> WL_020_09_809 Boot: B2_020_09_016 <b>EXC:</b> 020.09.001		<b>SCM:</b> P651 SIMM 0180706F50 App Sftwr PC5091103000009542 Boot2 PC5091002000009016 <b>WL:</b> U134 PC5095204000009809 U135 PC5095104000009809 <b>EXC:</b> PC5093104000009001	<b>SCM:</b> IR_020_09_542 <b>WL:</b> WL_020_09_809 Boot: B2_020_09_016 <b>EXC:</b> 020.09.001
	R9.04	<b>SCM:</b> P651 SIMM 0180706F47 App Sftwr PC5091103000009044 Boot2 PC5091002000009016 <b>WL:</b> U134 PC5095204000009809 U135 PC5095104000009809 <b>EXC:</b> PC5093104000009003	<b>SCM:</b> SC_020_09_044 <b>WL:</b> WL_020_09_809 Boot: B2_020_09_016 <b>EXC:</b> 020.09.003		<b>SCM:</b> P651 SIMM 0180706F50 App Sftwr PC5091103000009544 Boot2 PC5091002000009016 <b>WL:</b> U134 PC5095204000009809 U135 PC5095104000009809 <b>EXC:</b> PC5093104000009003	<b>SCM:</b> IR_020_09_544 <b>WL:</b> WL_020_09_809 Boot: B2_020_09_016 <b>EXC:</b> 020.09.003
	R9.04.03	<b>SCM:</b> P651 SIMM 0180706F47 App Sftwr PC5091103000009044 Boot2 PC5091002000009021 <b>WL:</b> U134 PC5095204000009809 U135 PC5095104000009809 <b>EXC:</b> PC5093104000009003	<b>SCM:</b> SC_020_09_044 <b>WL:</b> WL_020_09_809 Boot: B2_020_09_021 <b>EXC:</b> 020.09.003		<b>SCM:</b> P651 SIMM 0180706F50 App Sftwr PC5091103000009544 Boot2 PC5091002000009021 <b>WL:</b> U134 PC5095204000009809 U135 PC5095104000009809 <b>EXC:</b> PC5093104000009003	<b>SCM:</b> IR_020_09_544 <b>WL:</b> WL_020_09_809 Boot: B2_020_09_021 <b>EXC:</b> 020.09.003
R09.05.00	R9.05	<b>SCM:</b> P651 SIMM 0180706F47 App Sftwr PC5091103000009055 Boot2 PC5091002000009022 <b>WL:</b> U134 PC5095204000009812 U135 PC5095104000009812 <b>EXC:</b> PC5093104000009004	<b>SCM:</b> SC_020_09_055 <b>WL:</b> WL_020_09_812 Boot: B2_020_09_022 <b>EXC:</b> 020.09.004	SZ2.03 <sup>2</sup>	<b>SCM:</b> P651 SIMM 0180706F50 App Sftwr PC5091103000009552 Boot2 PC5091002000009022 <b>WL:</b> U134 PC5095204000009812 U135 PC5095104000009812 <b>EXC:</b> PC5093104000009004	<b>SCM:</b> IR_020_09_552 <b>WL:</b> WL_020_09_812 Boot: B2_020_09_022 <b>EXC:</b> 020.09.004
R09.06.00	R9.06	<b>SCM:</b> P651 SIMM 0180706F47 App Sftwr PC5091103000009062 Boot2 PC5091002000009025 <b>WL:</b> U134 PC5095204000009813 U135 PC5095104000009813 <b>EXC:</b> PC5093104000009004	<b>SCM:</b> SC_020_09_062 <b>WL:</b> WL_020_09_813 Boot: B2_020_09_025 <b>EXC:</b> 020.09.004	SZ2.03 <sup>2</sup>	<b>SCM:</b> P651 SIMM 0180706F50 App Sftwr PC5091103000009558 Boot2 PC5091002000009025 <b>WL:</b> U134 PC5095204000009813 U135 PC5095104000009813 <b>EXC:</b> PC5093104000009004	<b>SCM:</b> IR_020_09_558 <b>WL:</b> WL_020_09_813 Boot: B2_020_09_025 <b>EXC:</b> 020.09.004
R09.07.00	R9.07	<b>SCM:</b> P651 SIMM 0180706F47 App Sftwr PC509F103000009068 Boot2 PC5091002000009026 <b>WL:</b> U134 PC5095204000009813 U135 PC5095104000009813 <b>EXC:</b> PC5093104000009005	<b>SCM:</b> SC_020_09_068 <b>WL:</b> WL_020_09_813 Boot: B2_020_09_026 <b>EXC:</b> 020.09.005	SZ2.03 <sup>2</sup>	<b>SCM:</b> P651 SIMM 0180706F50 App Sftwr PC509F104000009564 Boot2 PC5091002000009026 <b>WL:</b> U134 PC5095204000009813 U135 PC5095104000009813 <b>EXC:</b> PC5093104000009005	<b>SCM:</b> IR_020_09_564 <b>WL:</b> WL_020_09_813 Boot: B2_020_09_026 <b>EXC:</b> 020.09.005
R10.00.00	R10.00	<b>SCM:</b> P651 SIMM 0180706F47 App Sftwr PC509F10300010002 Boot2 PC5091002000010001 <b>WL:</b> U134 PC5095204000009813 U135 PC5095104000009813 <b>EXC:</b> PC5093104000009005	<b>SCM:</b> SC_020_10_006 <b>WL:</b> WL_020_09_813 Boot: B2_020_10_001 <b>EXC:</b> 020.09.005	SZ2.03 <sup>2</sup>	<b>SCM:</b> P651 SIMM 0180706F50 App Sftwr PC509F10400010502 Boot2 PC5091002000010001 <b>WL:</b> U134 PC5095204000009813 U135 PC5095104000009813 <b>EXC:</b> PC5093104000009005	<b>SCM:</b> IR_020_10_506 <b>WL:</b> WL_020_09_813 Boot: B2_020_10_001 <b>EXC:</b> 020.09.005
R10.01.00	R10.01	<b>SCM:</b> P651 SIMM 0180706F47 App Sftwr PC509F10300010013 Boot2 PC5091002000010001 <b>WL:</b> U134 PC5095204000009813 U135 PC5095104000009813 <b>EXC:</b> PC5093104000009005	<b>SCM:</b> SC_020_10_013 <b>WL:</b> WL_020_09_813 Boot: B2_020_10_001 <b>EXC:</b> 020.09.005	SZ2.03 <sup>2</sup>	<b>SCM:</b> P651 SIMM 0180706F50 App Sftwr PC509F10400010513 Boot2 PC5091002000010001 <b>WL:</b> U134 PC5095204000009813 U135 PC5095104000009813 <b>EXC:</b> PC5093104000009005	<b>SCM:</b> IR_020_10_513 <b>WL:</b> WL_020_09_813 Boot: B2_020_10_001 <b>EXC:</b> 020.09.005

**Table 7-4** Factory Shipped Upgrade Kit<sup>1</sup> RSS Compatibility (for stations without Software Download Capability)

RSS Version Release	Conventional/6809 Trunking			IntelliRepeater/SMARTZONE		
	Release	Software/IC Part Numbers	Software Version (Note 1)	Release	Software/IC Part Numbers	Software Version (Note 1)
R10.02.00	R10.02	<b>SCM:</b> P651 SIMM 0180706F47 App Sftwr PC509F10300010021 Boot2 PC5091002000010001 <b>WL:</b> U134 PC5095204000010806 U135 PC5095104000010806 <b>EXC:</b> PC5093104000009005	<b>SCM:</b> SC_020_10_021 <b>WL:</b> WL_020_10_806 Boot: B2_020_10_001 <b>EXC:</b> 020.09.005	SZ2.03 <sup>2</sup>	<b>SCM:</b> P651 SIMM 0180706F50 App Sftwr PC509F10400010520 Boot2 PC5091002000010001 <b>WL:</b> U134 PC5095204000010806 U135 PC5095104000010806 <b>EXC:</b> PC5093104000009005	<b>SCM:</b> IR_020_10_520 <b>WL:</b> WL_020_10_806 Boot: B2_020_10_001 <b>EXC:</b> 020.09.005
R10.03.00	R10.03	<b>SCM:</b> P651 SIMM 0180706F47 App Sftwr PC509F10300010030 Boot2 PC5091002000010002 <b>WL:</b> U134 PC5095204000010807 U135 PC5095104000010807 <b>EXC:</b> PC5093104000009005	<b>SCM:</b> SC_020_10_030 <b>WL:</b> WL_020_10_807 Boot: B2_020_10_002 <b>EXC:</b> 020.09.005	SZ2.03 <sup>2</sup>	<b>SCM:</b> P651 SIMM 0180706F50 App Sftwr PC509F10400010527 Boot2 PC5091002000010002 <b>WL:</b> U134 PC5095204000010807 U135 PC5095104000010807 <b>EXC:</b> PC5093104000009005	<b>SCM:</b> IR_020_10_527 <b>WL:</b> WL_020_10_807 Boot: B2_020_10_002 <b>EXC:</b> 020.09.005
R10.04.00	R10.04	<b>SCM:</b> P651 SIMM 0180706F47 App Sftwr PC509F10300010042 Boot2 PC5091002000010003 <b>WL:</b> U134 PC5095204000010807 U135 PC5095104000010807 <b>EXC:</b> PC5093104000009005	<b>SCM:</b> SC_020_10_042 <b>WL:</b> WL_020_10_807 Boot: B2_020_10_003 <b>EXC:</b> 020.09.005	SZ2.03 <sup>2</sup>	<b>SCM:</b> P651 SIMM 0180706F50 App Sftwr PC509F10400010536 Boot2 PC5091002000010003 <b>WL:</b> U134 PC5095204000010807 U135 PC5095104000010807 <b>EXC:</b> PC5093104000009005	<b>SCM:</b> R_020_10_536 <b>WL:</b> WL_020_10_807 Boot: B2_020_10_003 <b>EXC:</b> 020.09.005
R10.05.00	R10.05	<b>SCM:</b> P651 SIMM 0180706F47 App Sftwr PC509F10300010049 Boot2 PC5091002000010008 <b>WL:</b> U134 PC5095204000010812 U135 PC5095104000010812 <b>EXC:</b> PC5093104000009005	<b>SCM:</b> SC_020_10_049 <b>WL:</b> WL_020_10_812 Boot: B2_020_10_008 <b>EXC:</b> 020.09.005	SZ2.03 <sup>2</sup>	<b>SCM:</b> P651 SIMM 0180706F50 App Sftwr PC509F10400010543 Boot2 PC5091002000010008 <b>WL:</b> U134 PC5095204000010812 U135 PC5095104000010812 <b>EXC:</b> PC5093104000009005	<b>SCM:</b> IR_020_10_543 <b>WL:</b> WL_020_10_812 Boot: B2_020_10_008 <b>EXC:</b> 020.09.005
R10.06.00	R10.06	<b>SCM:</b> P651 SIMM 0180706F47 App Sftwr PC509F10300010058 Boot2 PC5091002000010012 <b>WL:</b> U134 PC5095204000010816 U135 PC5095104000010816 <b>EXC:</b> PC5093104000009005	<b>SCM:</b> SC_020_10_058 <b>WL:</b> WL_020_10_816 Boot: B2_020_10_012 <b>EXC:</b> 020.09.005	SZ2.03 <sup>2</sup>	<b>SCM:</b> P651 SIMM 0180706F50 App Sftwr PC509F10400010552 Boot2 PC5091002000010012 <b>WL:</b> U134 PC5095204000010816 U135 PC5095104000010816 <b>EXC:</b> PC5093104000009005	<b>SCM:</b> IR_020_10_552 <b>WL:</b> WL_020_10_816 Boot: B2_020_10_012 <b>EXC:</b> 020.09.005
R14.00.00	R14.00			SZ2.0.3	<b>SCM:</b> P651 SIMM 0180706F51 App Sftwr PC509F1040000145xx Boot2 PC509F104000014001 <b>(3)WL:</b> U134 PC5095204000010816 U135 PC5095104000010816 App Sftwr PC509F02N000014501 <b>EXC:</b> PC509E02M000009017	<b>SCML:</b> IR_020_14_501 <b>WL:</b> WL_020_14_001 Boot: B2_020_14_001 <b>EXC:</b> 020.09.017

Notes:

1. No further development for these upgrade kits.
2. The software versions may be displayed by selecting *Status Report* from the *Service* menu, or by selecting *Status Panel/Software Version/Set Date and Time* from the *Service* menu.
3. Stations in systems running SZ2.0.3 are not software download capable.

**Table 7-5** CLN6960 Station Control Boards (IntelliRepeater 5.0 Stations) RSS Version Compatibility

<b>RSS Version Release</b>	<b>Release</b>	<b>Software/IC Part Numbers</b>	<b>Software Version<sup>1</sup></b>
R10.00.00	SZ5.0	<b>SCM:</b>	<b>SCM</b> IR_005_01_500
R10.01.00		P651 SIMM 0180706F51	<b>Boot</b> B2_005_01_001
R10.02.00		App Sftwr PC509F1050000501500	<b>EXC</b> 020.09.005
		Boot2 PC509F022000501001	
		<b>EXC</b> PC5093104000009005	
R10.03.00		<b>SCM:</b>	<b>SCM</b> IR_005_01_501
		P651 SIMM 0180706F51	<b>Boot</b> B2_005_01_001
		App Sftwr PC509F1050000501501	<b>EXC</b> 020.09.005
		Boot2 PC509F022000501001	
		<b>EXC</b> PC5093104000009005	
R10.04.00		<b>SCM:</b>	<b>SCM</b> IR_005_01_502
R10.05.00		P651 SIMM 0180706F51	<b>Boot</b> B2_005_01_001
R10.06.00	App Sftwr PC509F1050000501502	<b>EXC</b> 020.09.005	
	Boot2 PC509F022000501001		
	<b>EXC</b> PC5093104000009005		
R10.07.00	<b>SCM:</b>	<b>SCM</b> IR_005_01_504	
R10.08.00	P651 SIMM 0180706F51	<b>Boot</b> B2_005_01_001	
R10.11.00	App Sftwr PC509F1050000501504	<b>EXC</b> 020.09.009	
R10.12.00	Boot2 PC509F022000501001		
	<b>EXC</b> PC5093104000009009		
R12.01.00	<b>SCM</b>	<b>SCM</b> IR_005_01_504	
R12.02.00	P651 SIMM 0180706F51	<b>Boot</b> B2_005_01_001	
R12.03.00	App Sftwr PC509F1050000501504	<b>EXC</b> 020.09.009	
	Boot2 PC509F022000501001		
	<b>EXC</b> PC509E02M000009010		
Notes:			
1. The software versions may be displayed by selecting <i>Status Report</i> from the <i>Service</i> menu, or by selecting <i>Status Panel/Software Version/Set Date and Time</i> from the <i>Service</i> menu.			

**Table 7-6** CLN7462 Station Control Boards (“Limited” QUANTAR) RSS Version Compatibility

<b>RSS Version Release</b>	<b>Release</b>	<b>Software/IC Part Numbers</b>	<b>Software Version<sup>1</sup></b>
R10.04.00	R10.04	<b>SCM:</b> P651 SIMM 0180706F47 App Sftwr KC509024000100400 Boot2 PC5091002000010004 <b>WL:</b> U134 PC5095204000010008 U135 PC5095104000010008 <b>EXC:</b> PC5093104000009005	<b>SCM</b> LQ_020_10_703 <b>WL</b> WL_020_10_008 <b>Boot</b> B2_020_10_004 <b>EXC</b> 020.09.005
R10.05.00	R10.05	<b>SCM:</b> P651 SIMM 0180706F47 App Sftwr KC509024000100500 Boot2 PC5091002000010007 <b>WL:</b> U134 PC5095204000010012 U135 PC5095104000010012 <b>EXC:</b> PC5093104000009005	<b>SCM</b> LQ_020_10_708 <b>WL</b> WL_020_10_012 <b>Boot</b> B2_020_10_007 <b>EXC</b> 020.09.005
R10.06.00	R10.06	<b>SCM:</b> P651 SIMM 0180706F47 App Sftwr KC509024000100600 Boot2 PC5091002000010012 <b>WL:</b> U134 PC5095204000010018 U135 PC5095104000010018 <b>EXC:</b> PC5093104000009005	<b>SCM</b> LQ_020_10_712 <b>WL</b> WL_020_10_018 <b>Boot</b> B2_020_10_012 <b>EXC</b> 020.09.005
R10.07.00	R10.07	<b>SCM:</b> P651 SIMM 0180706F47 App Sftwr KC509024000100700 Boot2 PC5091002000010016 <b>WL:</b> U134 PC5095204000010021 U135 PC5095104000010021 <b>EXC:</b> PC5093104000009005	<b>SCM</b> LQ_020_10_717 <b>WL</b> WL_020_10_021 <b>Boot</b> B2_020_10_016 <b>EXC</b> 020.09.005
R10.08.00			

**Table 7-6** CLN7462 Station Control Boards (“Limited” QUANTAR) RSS Version Compatibility (continued)

RSS Version Release	Release	Software/IC Part Numbers	Software Version <sup>1</sup>
R10.11.00	R10.11	<b>SCM:</b> P651 SIMM 0180706F47 App Sftwr KC509024000101100 Boot2 PC5091002000010022 <b>WL:</b> U134 PC5095204000010025 U135 PC5095104000010025 <b>EXC:</b> PC5093104000009009	<b>SCM</b> LQ_020_10_731 <b>WL</b> WL_020_10_025 <b>Boot</b> B2_020_10_022 <b>EXC</b> 020.09.009
R10.12.00	R10.12	<b>SCM:</b> P651 SIMM 0180706F47 App Sftwr PC509F02H000010737 Boot2 PC5091002000010022 <b>WL:</b> U134 PC5095204000010025 U135 PC5095104000010025 <b>EXC:</b> PC509E02M000009010	<b>SCM</b> LQ_020_10_737 <b>WL</b> WL_020_10_025 <b>Boot</b> B2_020_10_022 <b>EXC</b> 020.09.009

Notes:

1. The software versions may be displayed by selecting Status Report from the Service menu, or by selecting Status Panel/Software Version/Set Date and Time from the Service menu.

## RSS Program Versions Compatibility

In general, each new version of the RSS program is backward compatible with previous versions. The following describes specific backward compatibility issues associated with the RSS program release version covered in this guide for RSS version R14.

R14 is 100% backward compatible with conventional, 6809 trunking, and IntelliRepeater station firmware as shown in the Table 7-1 through Table 7-6 with the following exceptions:

- The new RSS is a graphical user interface (GUI) and so the information is presented in a more intuitive and familiar Windows format.
- Due to added fields and screens, you may notice that these new fields are filled with default values. Similarly, you may receive error messages if you try to access these new fields. Ignore the default values and close the error message window. Operation of the RSS or station is not affected.
- Beginning with Release 12, Securenet was cancelled. Codeplugs configured for Securenet cannot be upgraded beyond version 10.

- Beginning with Release 13, ASTRO VSELP was cancelled. Codeplugs configured for ASTRO VSELP cannot be upgraded beyond version 12.
- Version 14 supports 800 MHz rebanding. To support rebanding of older 800 MHz systems, the IntelliRepeater application allows the operation of Securenet and ASTRO VSELP as well as ANALOG and ASTRO CAI. Thus Version 14 allows IntelliRepeater codeplugs configured for either Securenet or ASTRO VSELP to be upgraded to version 14.
- Version 14 does not allow Conventional or 6809 Trunking codeplugs configured for either Securenet or ASTRO VSELP to be upgraded beyond the limits imposed above, version 10 and version 12, respectively.



### IMPORTANT

RSS R1.00, R2.00, R3.00, and R3.01 are not forward compatible with station firmware R4.00 and later. These earlier RSS versions cannot read the later Version station codeplugs and display a warning message to the effect if attempted.



### NOTE

To support the various versions of frozen software and cancelled features, the RSS provides a default training codeplug for versions 10,12,13, and 14.



### NOTE

The RSS does not support Version 11 of the codeplug. Version 11 is supported by the Customer Service Software (CSS).

## Retrieving Station Software Versions

You must provide the station's current software version and its name when contacting Motorola's System Support Center (SSC). To access software version information from the connected station, perform the following procedure:

1. Connect to the station as outlined in "Connecting the PC to the Device RSS Port" on page 2-11.
2. Launch the RSS program as outlined in "Launching the RSS Program" on page 2-12.
3. Read the connected station's codeplug as outlined in "Reading the Device Codeplug" on page 2-14.
4. Click the + next to Service in the navigation pane to expand the service node.
5. Click Version Screen in the Service tree. The information pane displays the current version information as shown in the example below.

Station Control Firmware	R020.12.034	2003/07/23 11:37
Station Wireline Firmware	R020.12.008	2003/07/23 11:37
Station Exciter Firmware	R020.09.010	
Station Boot2 Firmware	R020.10.022	2003/04/02 10:40
Station Boot1 Firmware	R020.10.009	0000/00/00 00:00
Codeplug Version	12	

Help

## Retrieving Comparator Software Versions and Backplane ID

You must provide the comparator's current software version and its backplane ID when contacting Motorola's System Support Center (SSC). To access software version information from the connected station, perform the following procedure:

1. Connect to the comparator as outlined in "Connecting the PC to the Device RSS Port" on page 2-11.
2. Launch the RSS program as outlined in "Launching the RSS Program" on page 2-12.
3. Read the connected comparator's codeplug as outlined in "Reading the Device Codeplug" on page 2-14.
4. Click the + next to Service in the navigation pane to expand the service node.
5. Click Version screen in the Service tree. The information pane displays the current version information as shown in the examples below.



Control Card	Software Version	SW Part Number
AC 1	OC_R03.07.005	PC525F003000030700
Boot1	B1_R03.06.005	KC525F001000030600
Boot2	B2_R03.07.001	PC525F002000030700
<b>BackPlane ID:</b>		000002FC31B6
<b>CP Version:</b>		3.9

V/L Board	Boot SW Version	Wireline SW Version	Boot SW Part Number	Wireline SW Part Number
001	WVB_R03.06.002	WL_R03.07.003	PC525E401000030600	PC525F004000030700
002	NOT_INSTALLED	NOT_INSTALLED	NOT_INSTALLED	NOT_INSTALLED
003	NOT_INSTALLED	NOT_INSTALLED	NOT_INSTALLED	NOT_INSTALLED
004	NOT_INSTALLED	NOT_INSTALLED	NOT_INSTALLED	NOT_INSTALLED
005	NOT_INSTALLED	NOT_INSTALLED	NOT_INSTALLED	NOT_INSTALLED
006	NOT_INSTALLED	NOT_INSTALLED	NOT_INSTALLED	NOT_INSTALLED
007	NOT_INSTALLED	NOT_INSTALLED	NOT_INSTALLED	NOT_INSTALLED
008	NOT_INSTALLED	NOT_INSTALLED	NOT_INSTALLED	NOT_INSTALLED

**Primary Comparator in an Expanded Configuration**

Control Card	Software Version	SW Part Number
AC 1	OC_R03.07.005	PC525F003000030700
Boot1	B1_R03.06.005	KC525F001000030600
Boot2	B2_R03.07.001	PC525F002000030700
<b>BackPlane ID:</b>		000002FC31B6
<b>CP Version:</b>		3.9

V/L Board	Boot SW Version	Wireline SW Version	Boot SW Part Number	Wireline SW Part Number
001	WVB_R03.06.001	WL_R03.07.003	NOT_ASSIGNED	PC525F004000030700
002	WVB_R03.06.001	WL_R03.07.003	NOT_ASSIGNED	PC525F004000030700
003	WVB_R03.06.001	WL_R03.07.003	NOT_ASSIGNED	PC525F004000030700
004	WVB_R03.06.001	WL_R03.07.003	NOT_ASSIGNED	PC525F004000030700
005	NOT_INSTALLED	NOT_INSTALLED	NOT_INSTALLED	NOT_INSTALLED
006	NOT_INSTALLED	NOT_INSTALLED	NOT_INSTALLED	NOT_INSTALLED
007	NOT_INSTALLED	NOT_INSTALLED	NOT_INSTALLED	NOT_INSTALLED
008	NOT_INSTALLED	NOT_INSTALLED	NOT_INSTALLED	NOT_INSTALLED

**Standard Comparator or Secondary Comparator in an Expanded Configuration**

## Performing Upgrades

There are two possible upgrade paths:

- Upgrading a station’s codeplug to R14 firmware.
- Upgrading an archived codeplug file of a previous version of firmware to R14 firmware.

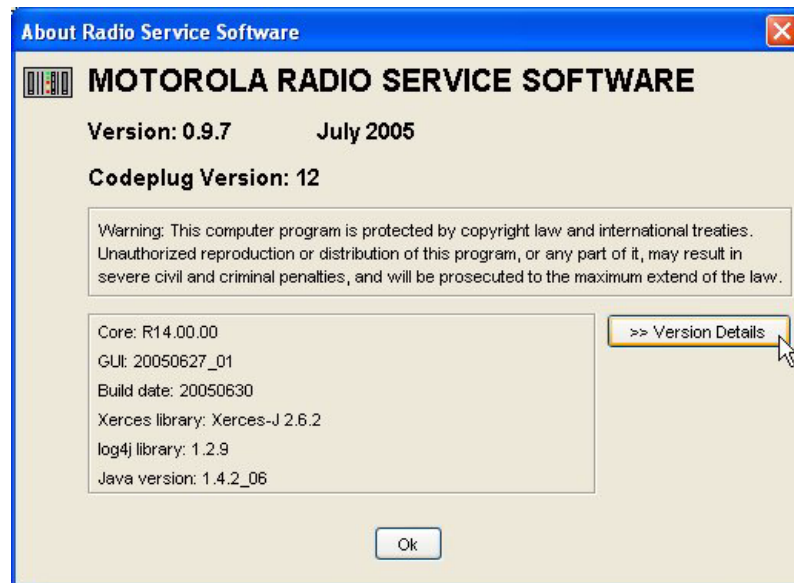
## Upgrading the Station’s Codeplug

You can upgrade the station’s current codeplug to that of this RSS codeplug version.

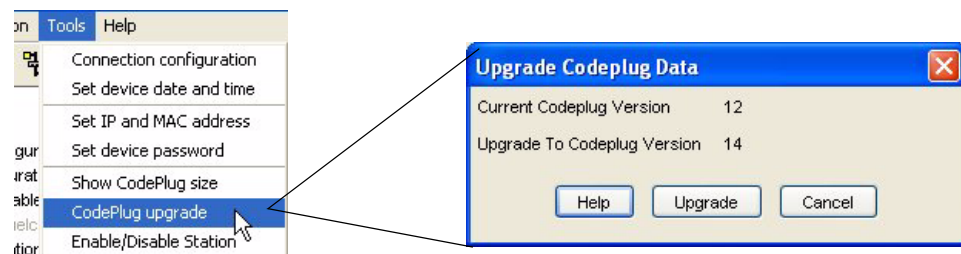
1. Check the current version of the station’s codeplug loaded in the RSS. See “Verifying the Device’s Configuration Data” on page 3-3.
2. Check the RSS’s codeplug version by clicking **Help** then **About**. The About window appears.



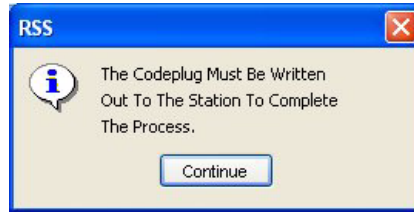
If you would like to see more details about the RSS, click **Version Details**. See the example below.



3. If you wish to upgrade the station's codeplug version, click **OK** to close the Versions window, then from the **Tools** menu, select **Codeplug upgrade**.



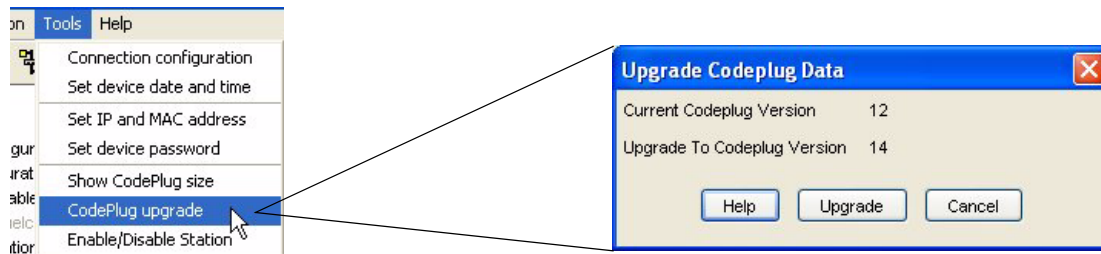
4. Click **Upgrade** to upgrade the station's codeplug. The following window appears.



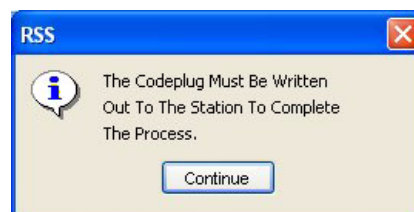
5. Click **Continue** to write the upgraded codeplug to the station and complete the upgrade process.

## Upgrading an Archived Codeplug File

1. Launch the RSS program.
2. Open the archive file to upgrade.
3. From the **Tools** menu, select **Codeplug upgrade**. The Upgrade Codeplug Data windows appears.



4. Click **Upgrade** to upgrade the station's codeplug. The following window appears.



5. Click **Continue** to write the upgraded codeplug to the station and complete the upgrade process.
6. Save the upgraded codeplug archive for installation in a station later.

# Features and System Capabilities

The following figures provide a summary of the features available in each release.

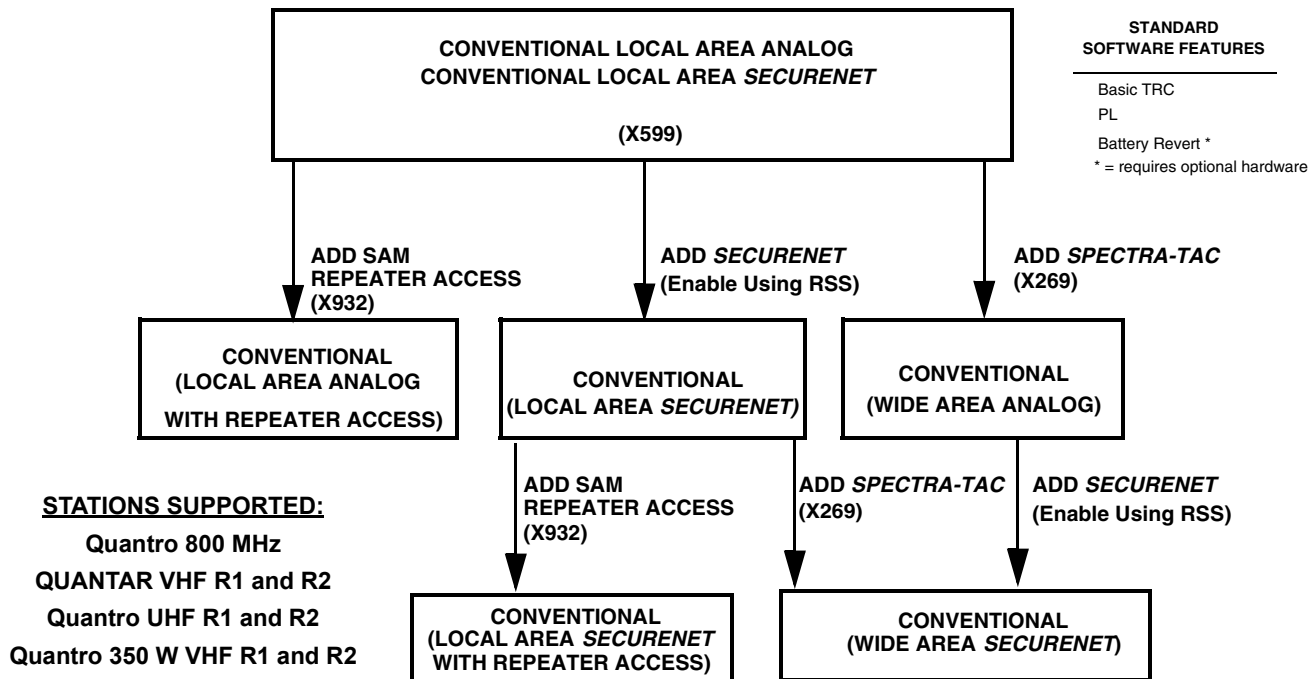


Figure 7-1 Release R1.00 Features and System Capabilities – Conventional

**STATIONS SUPPORTED**

- Quantro 800 MHz
- QUANTAR VHF R1 and R2
- Quantro UHF R1 through R3
- QUANTAR 900 MHz
- Quantro 350W VHF R1 and R2

**STANDARD SOFTWARE FEATURES**

- Basic TRC
- PL
- DPL
- Battery Revert \*
- Alarm Tones
- E & M Keying
- 12.5 kHz Channels
- 5 MHz External Reference
- \* = requires optional hardware

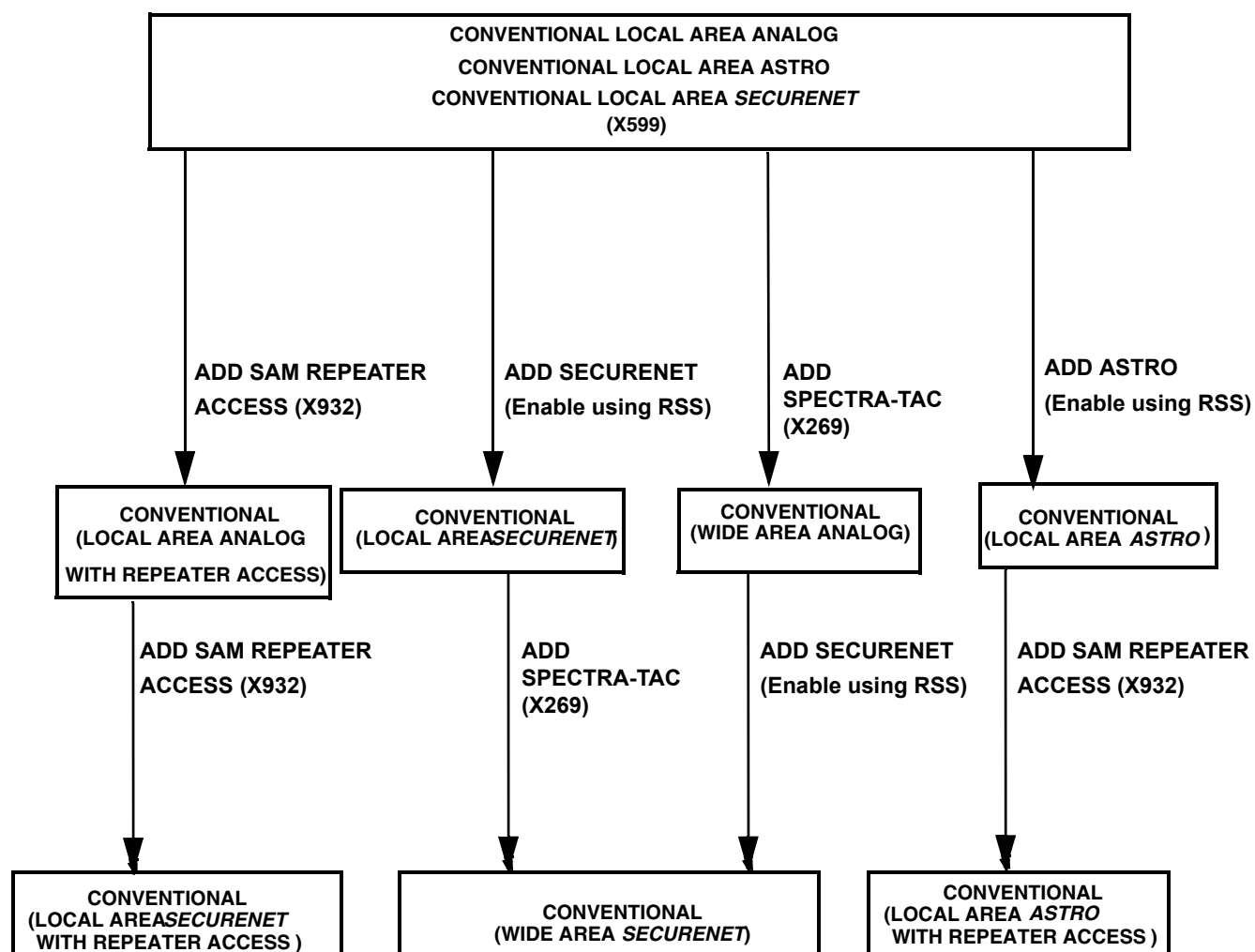


Figure 7-2 Release R2.00 Features and System Capabilities - Conventional

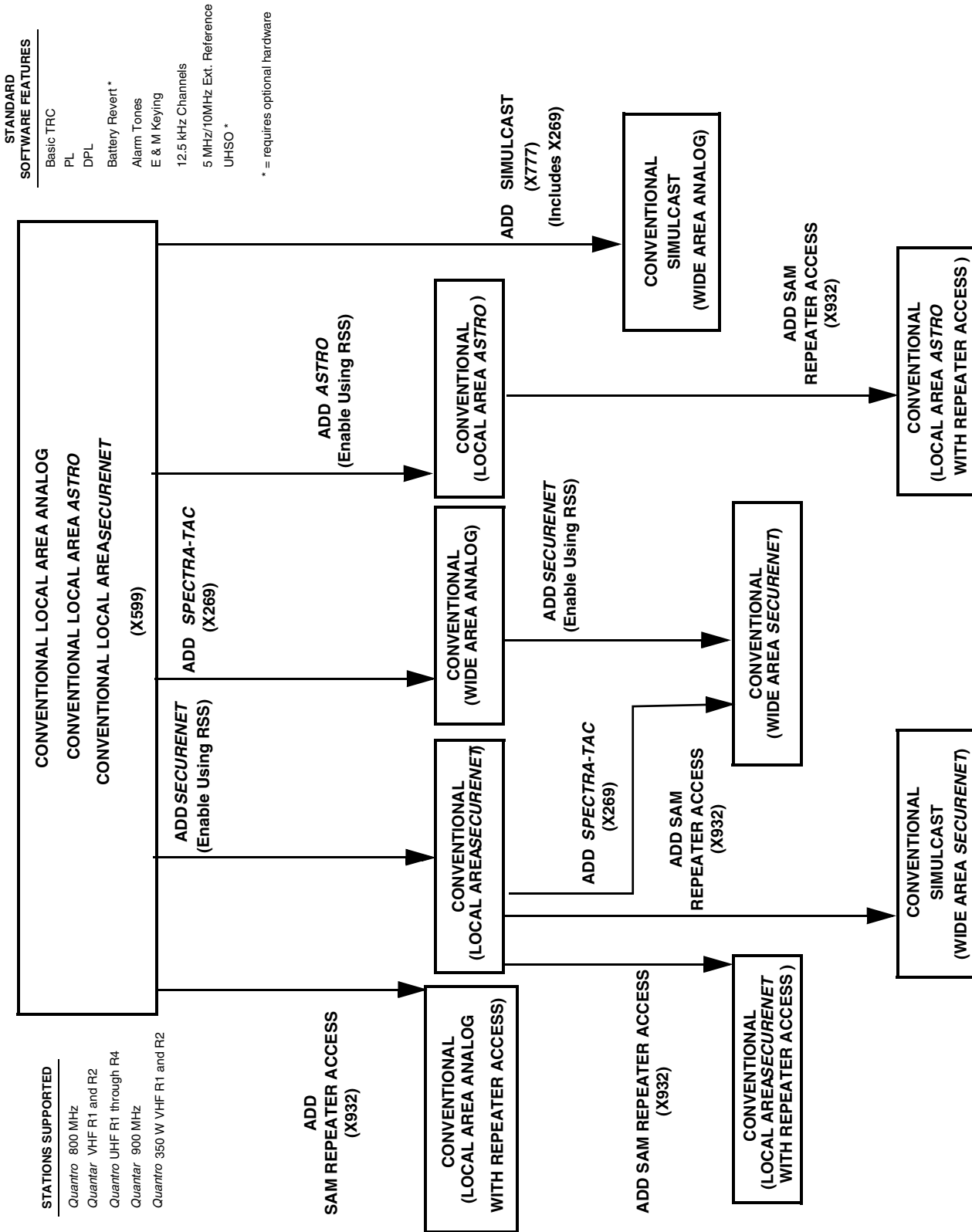


Figure 7-3 Release R3.00 / R3.01 Features and System Capabilities - Conventional

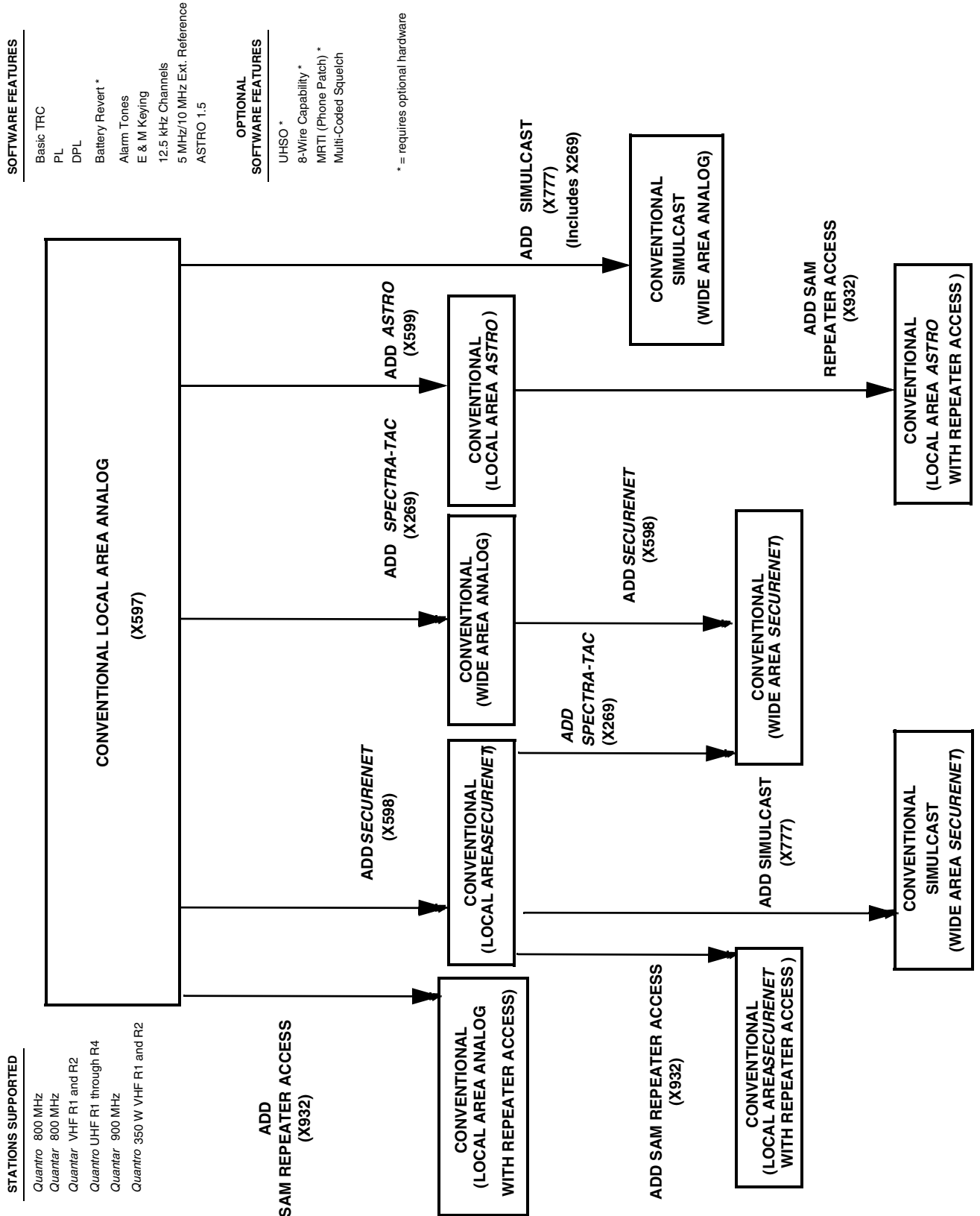


Figure 7-4 Release R4.00 Features and System Capabilities - Conventional

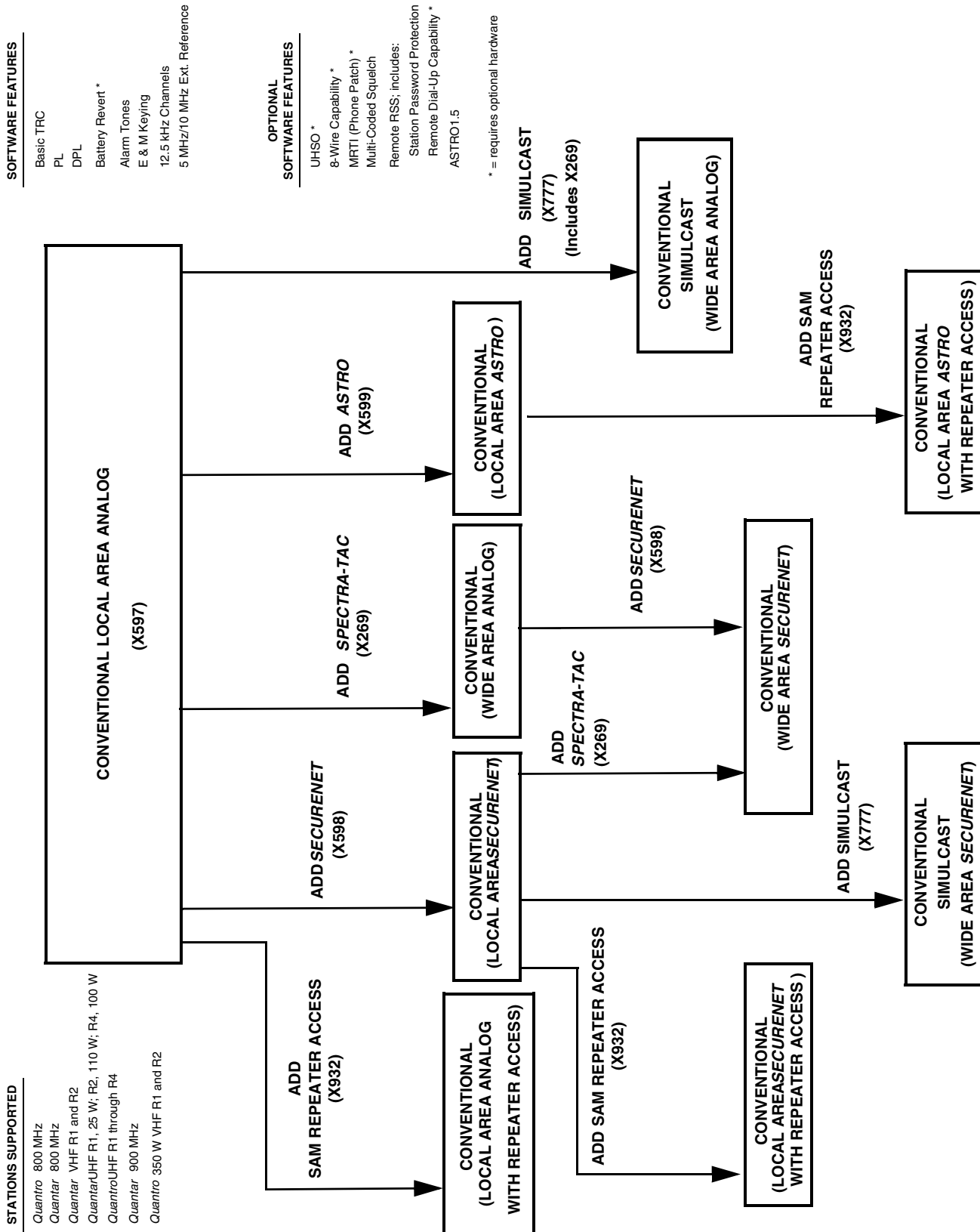


Figure 7-5 Release R5.00 Features and System Capabilities - Conventional



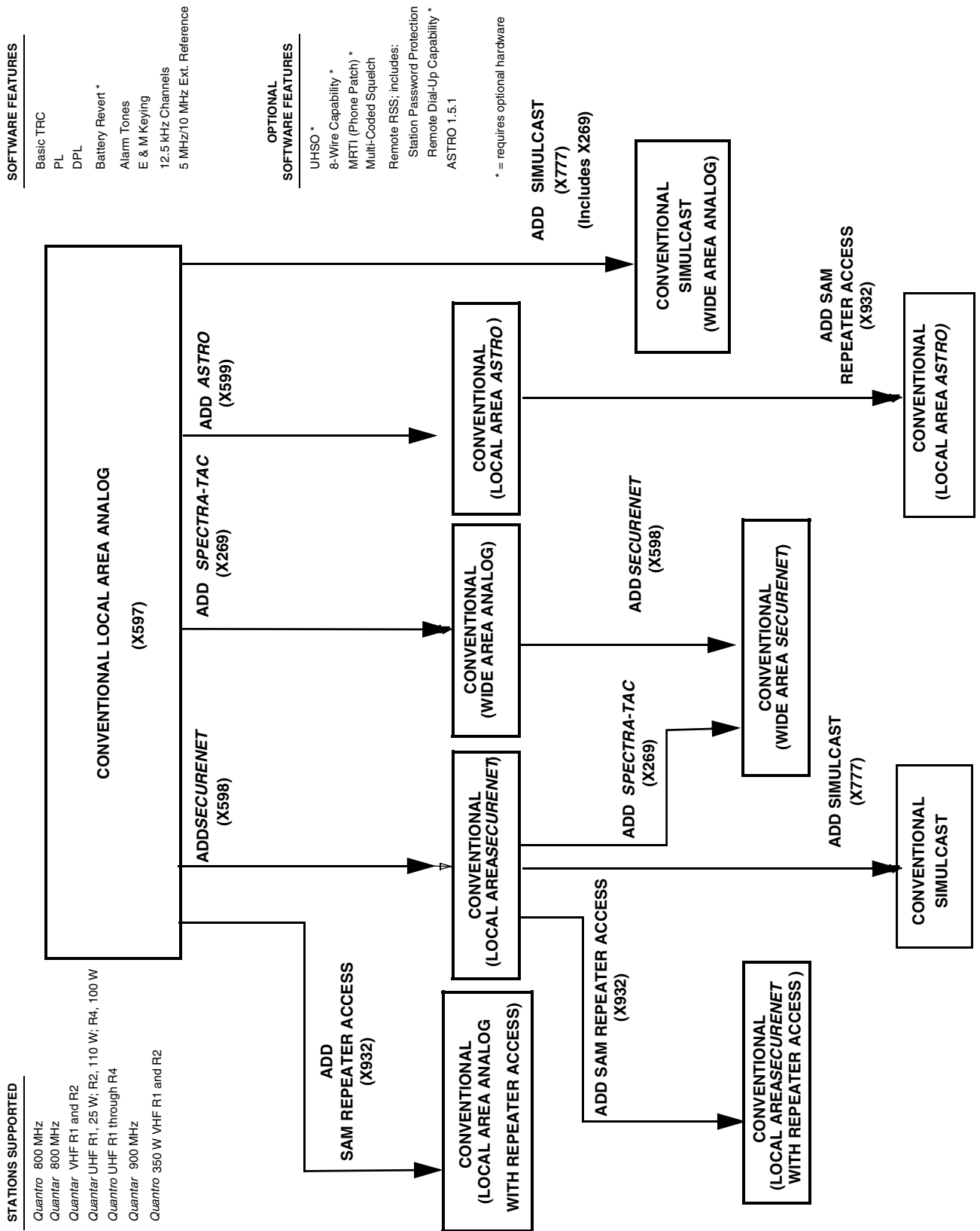


Figure 7-6 Release R6.00 Features and System Capabilities - Conventional

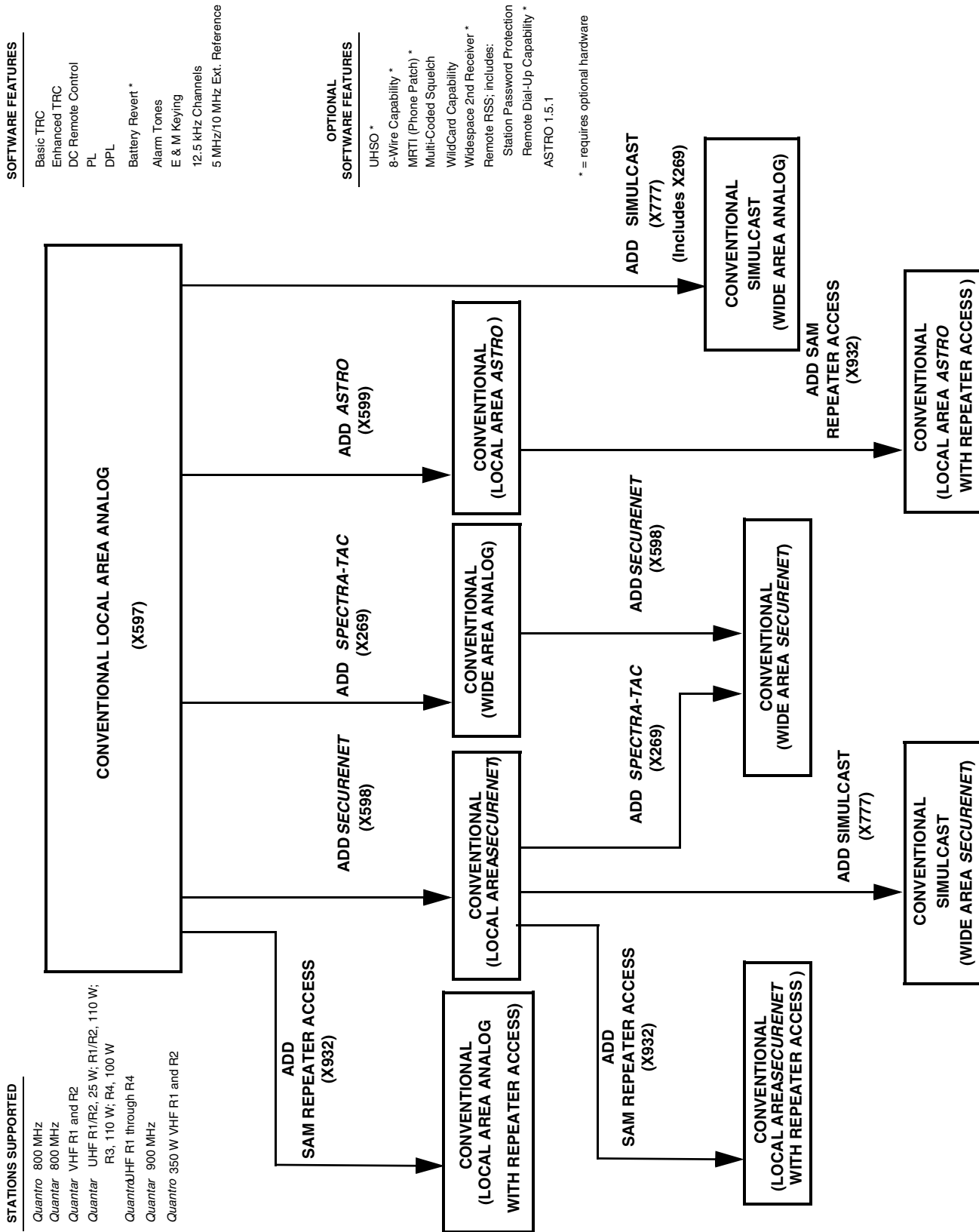


Figure 7-7 Release R7.00 Features and System Capabilities - Conventional

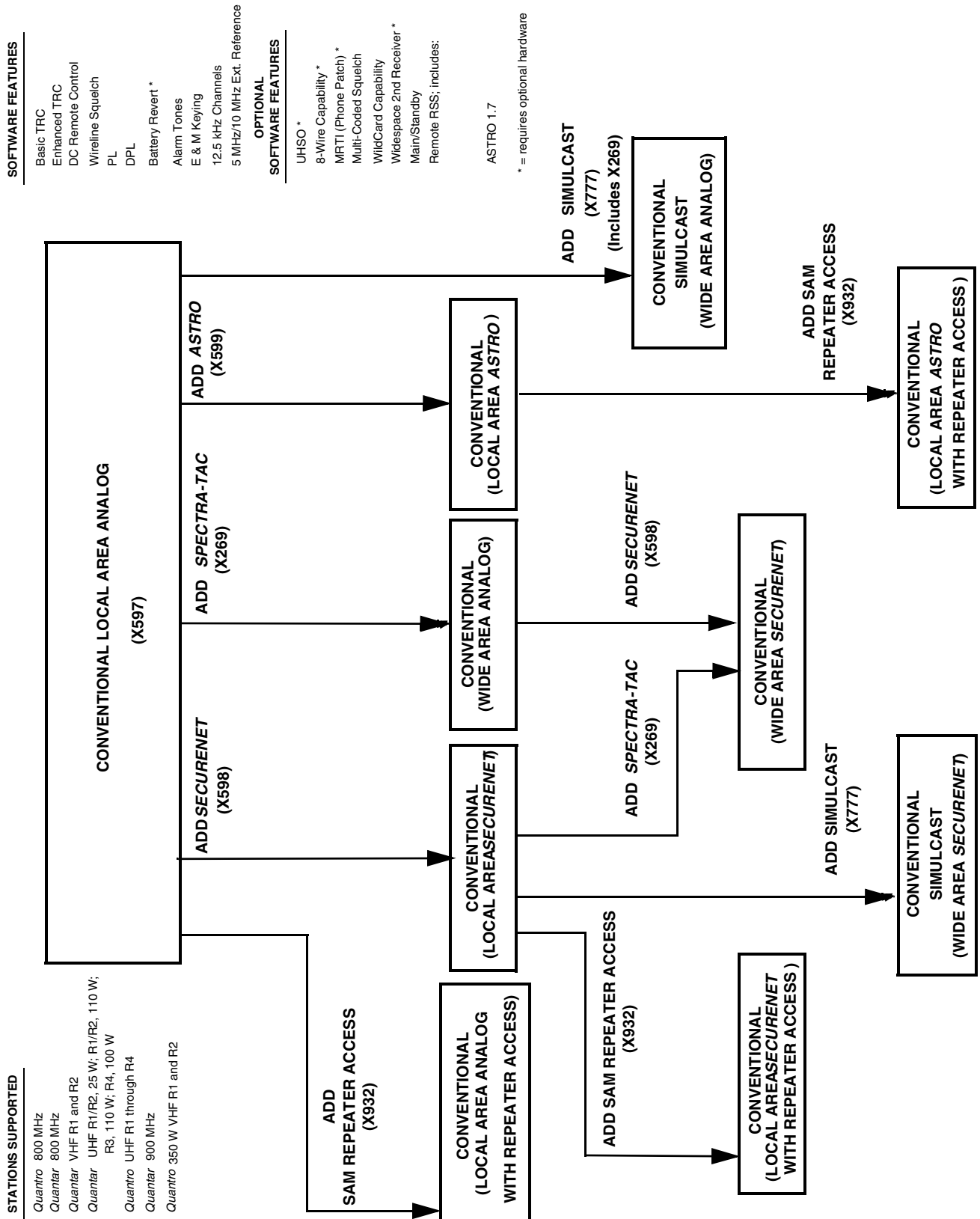


Figure 7-8 Release R07.02.02 Features and System Capabilities - Conventional

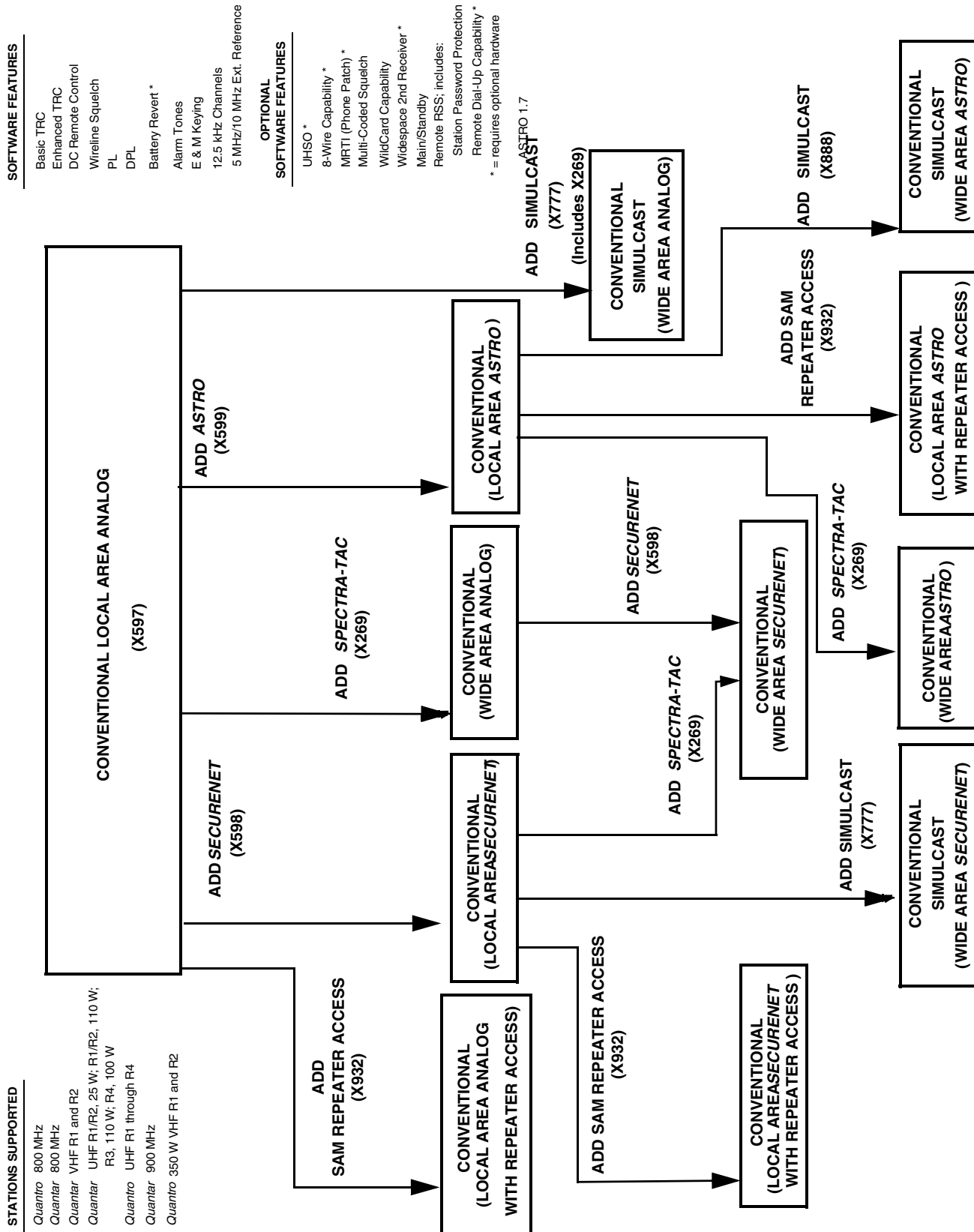


Figure 7-9 Release R08.00.00-R08.03.00 Features and System Capabilities - Conventional

**STATIONS SUPPORTED**

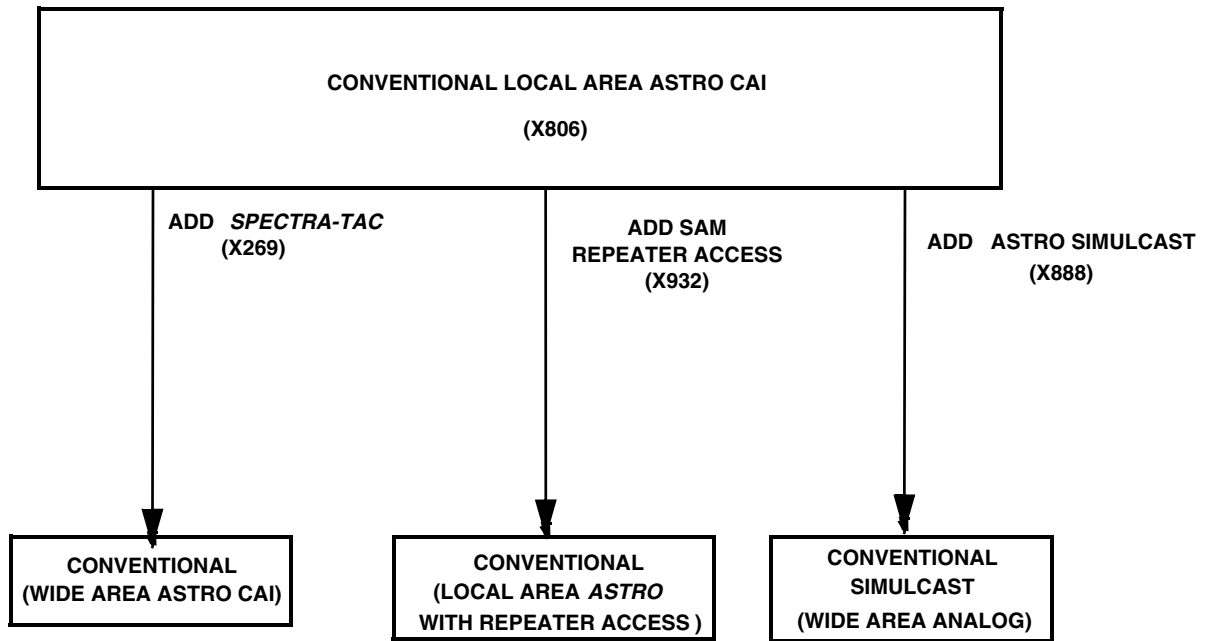
*Quantro* 800 MHz  
*Quantar* 800 MHz  
*Quantar* VHF R1 and R2  
*Quantar* UHF R1/R2, 25 W; R1/R2, 110 W;  
 R3, 110 W; R4, 100 W  
*Quantro* UHF R1 through R4  
*Quantar* 900 MHz  
*Quantro* 350 W VHF R1 and R2

**STANDARD SOFTWARE FEATURES**

Wireline Squelch  
 PL  
 DPL  
 Battery Revert \*  
 Alarm Tones  
 12.5 kHz Channels  
 5 MHz/10 MHz Ext. Reference  
 Software Download Capability

**OPTIONAL SOFTWARE FEATURES**

UHSO \*  
 ASTRO CAI 3.0  
 Remote RSS; includes:  
 Station Password Protection  
 Remote Dial-Up Capability \*  
 \* = requires optional hardware



**Figure 7-10** Release R09.00.00 Features and System Capabilities - Conventional

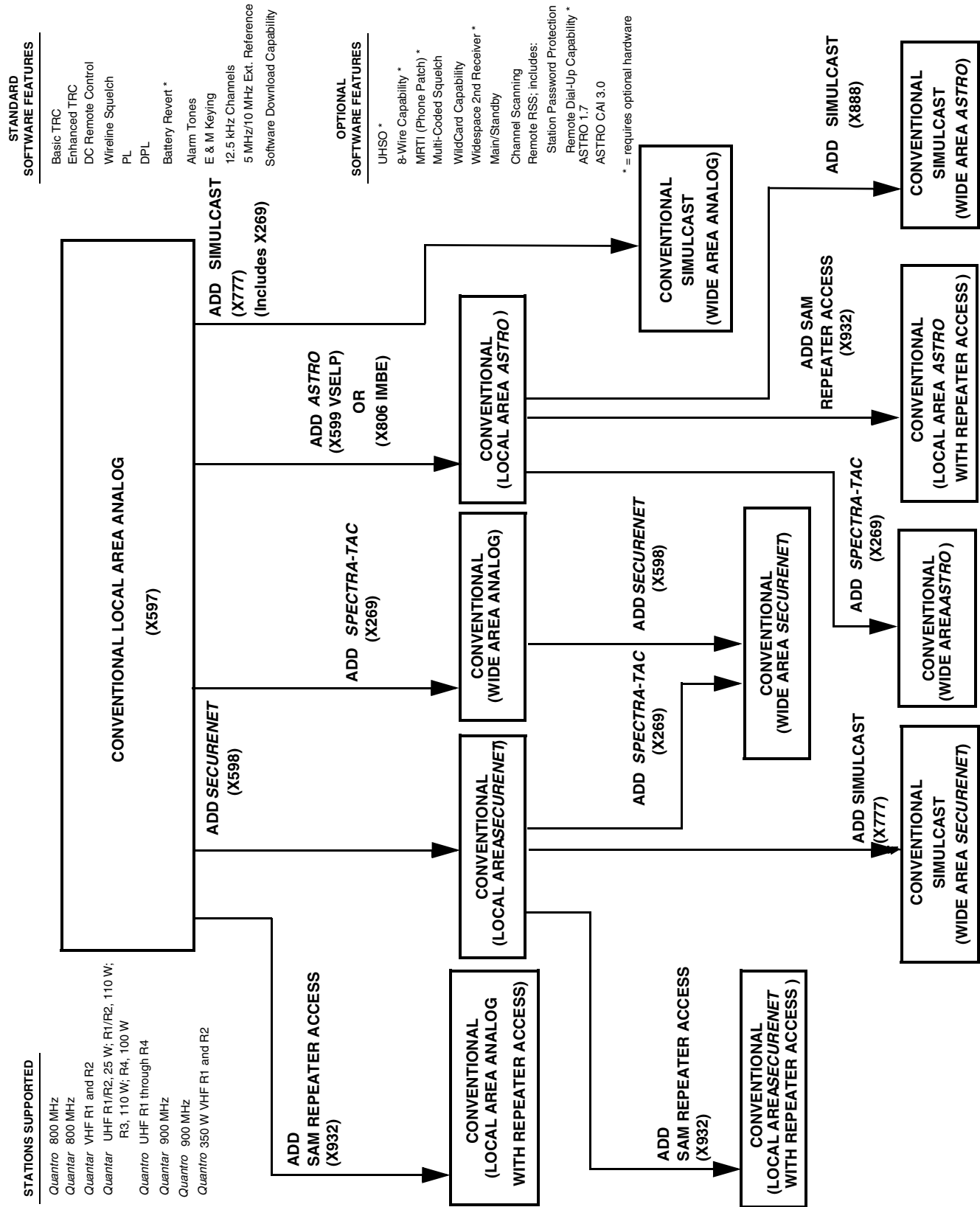


Figure 7-11 Release R09.02.01 Features and System Capabilities - Conventional

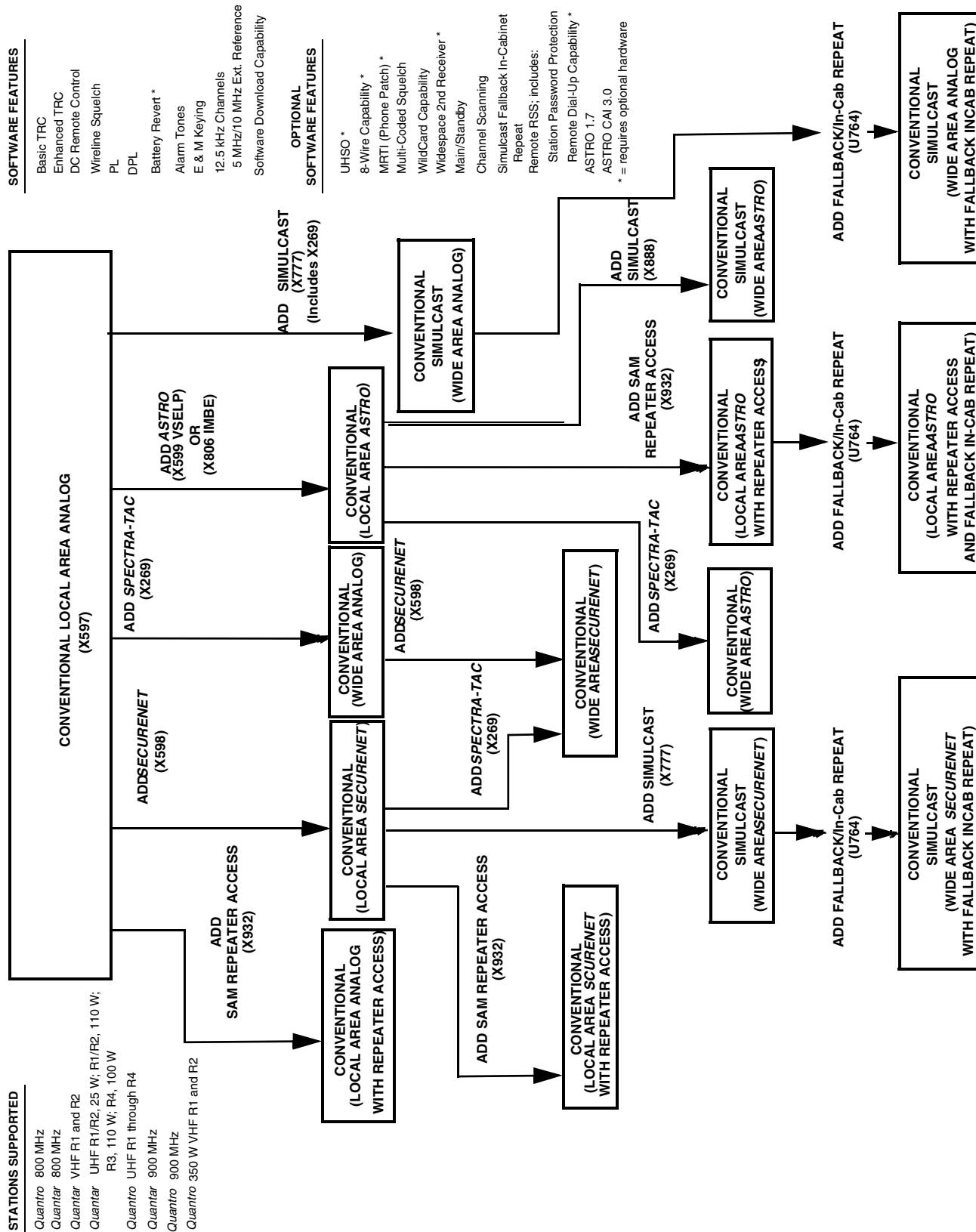
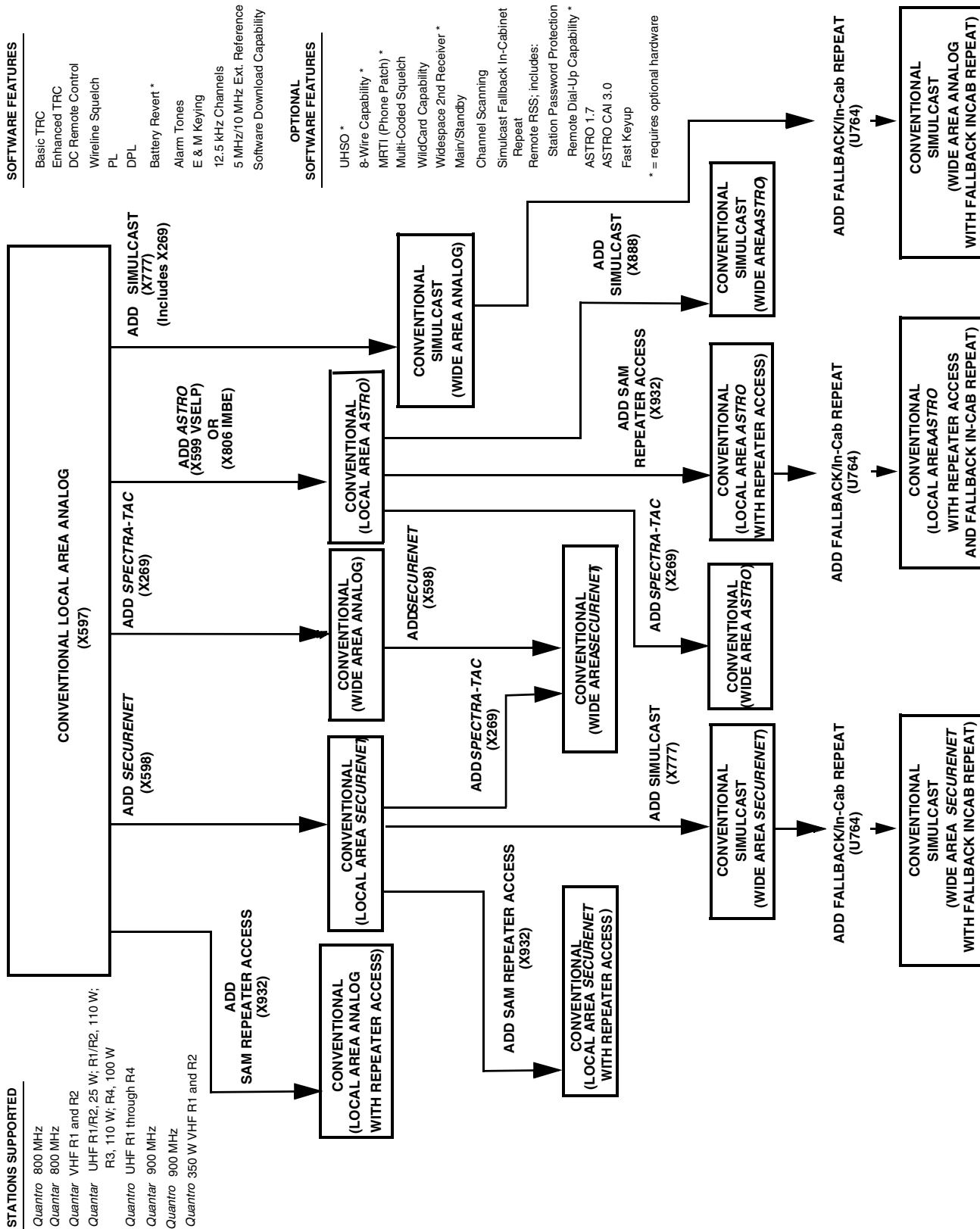


Figure 7-12 Release R09.03.00 Features and System Capabilities - Conventional



**Figure 7-13** Release R09.05.00/R09.06.00 Features and System Capabilities - Conventional





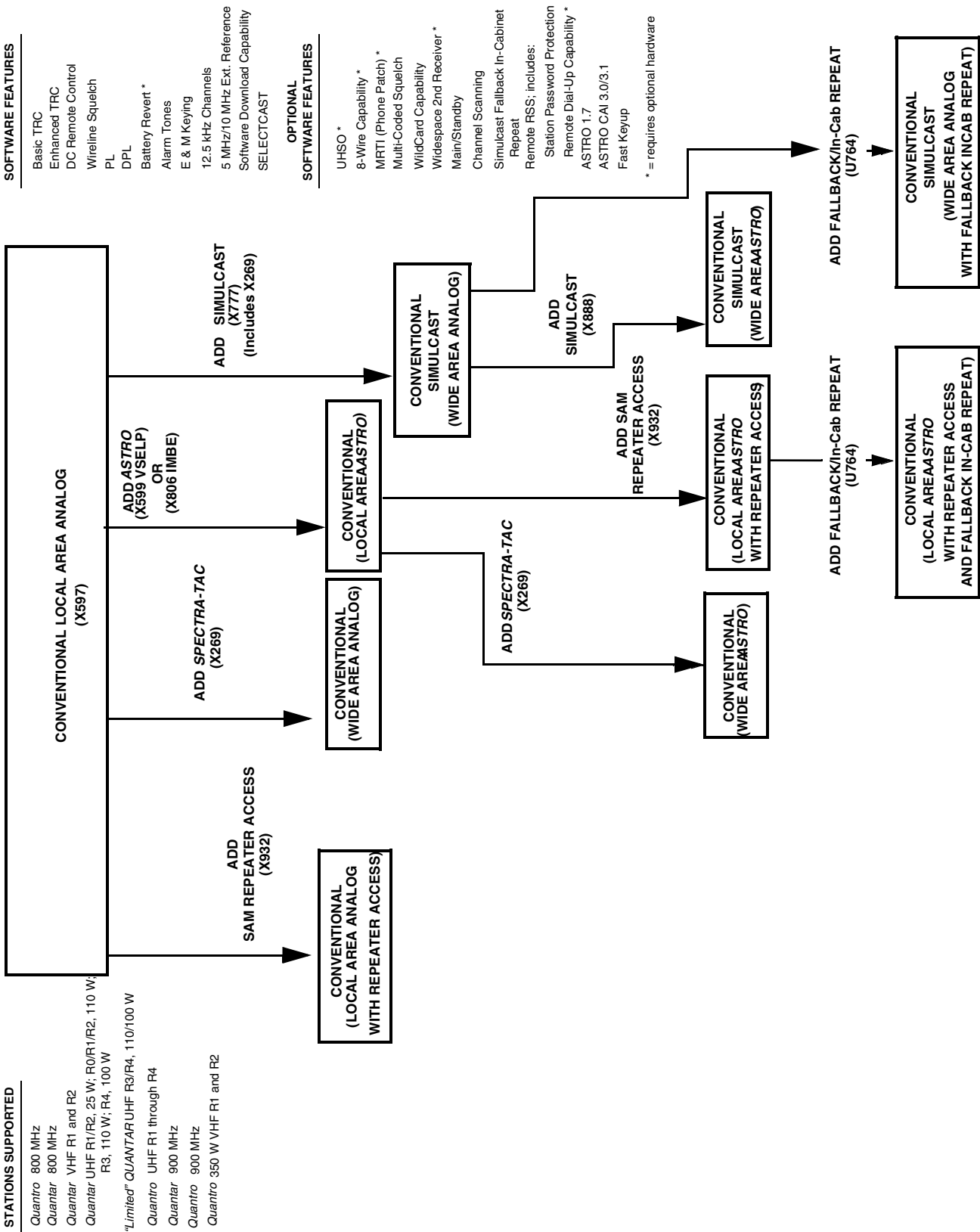


Figure 7-15 Release R12.01.00 through R12.03.00 Features and System Capabilities - Conventional

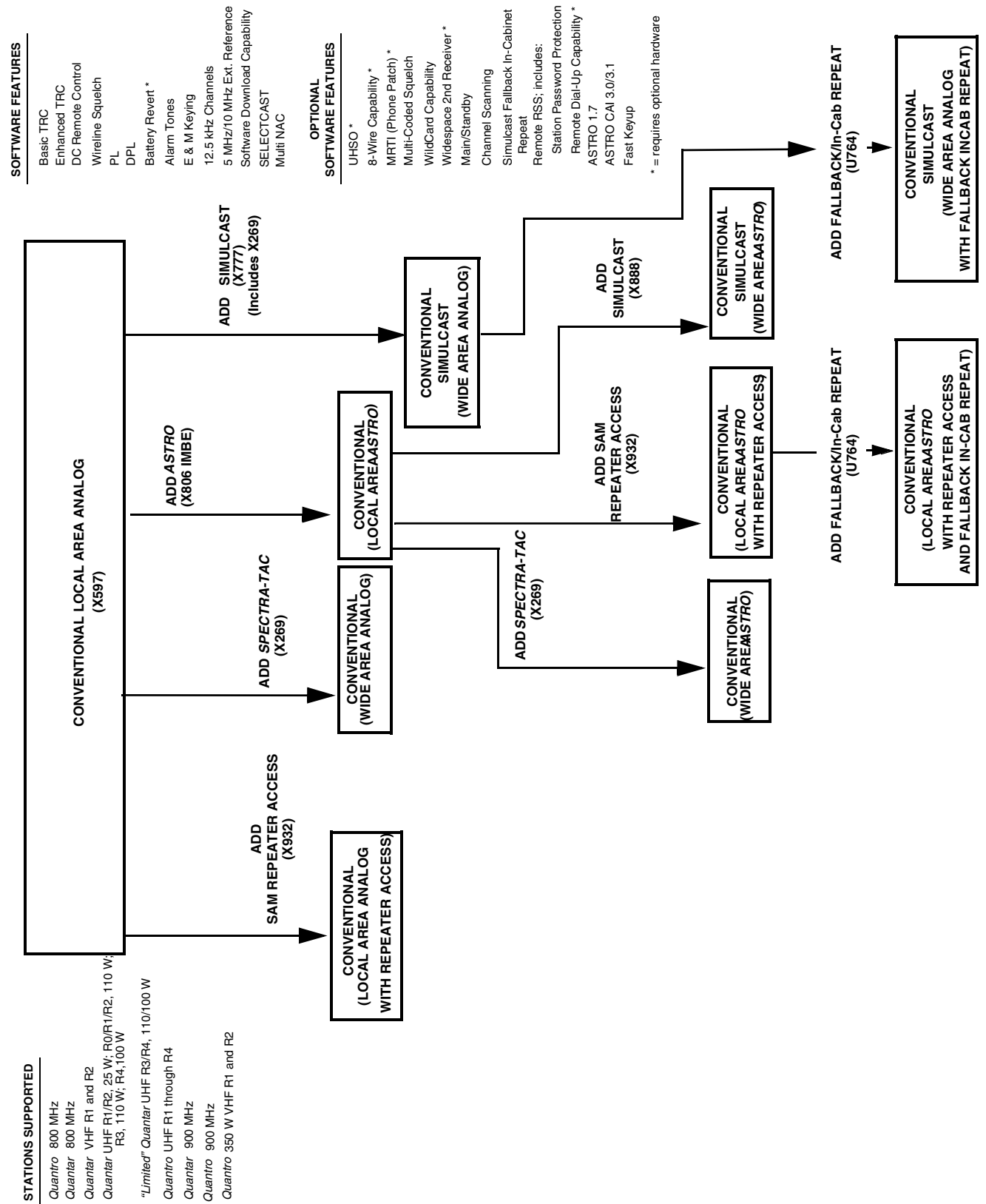


Figure 7-16 Release R13.00.00 through R13.02.00 Features and System Capabilities - Conventional

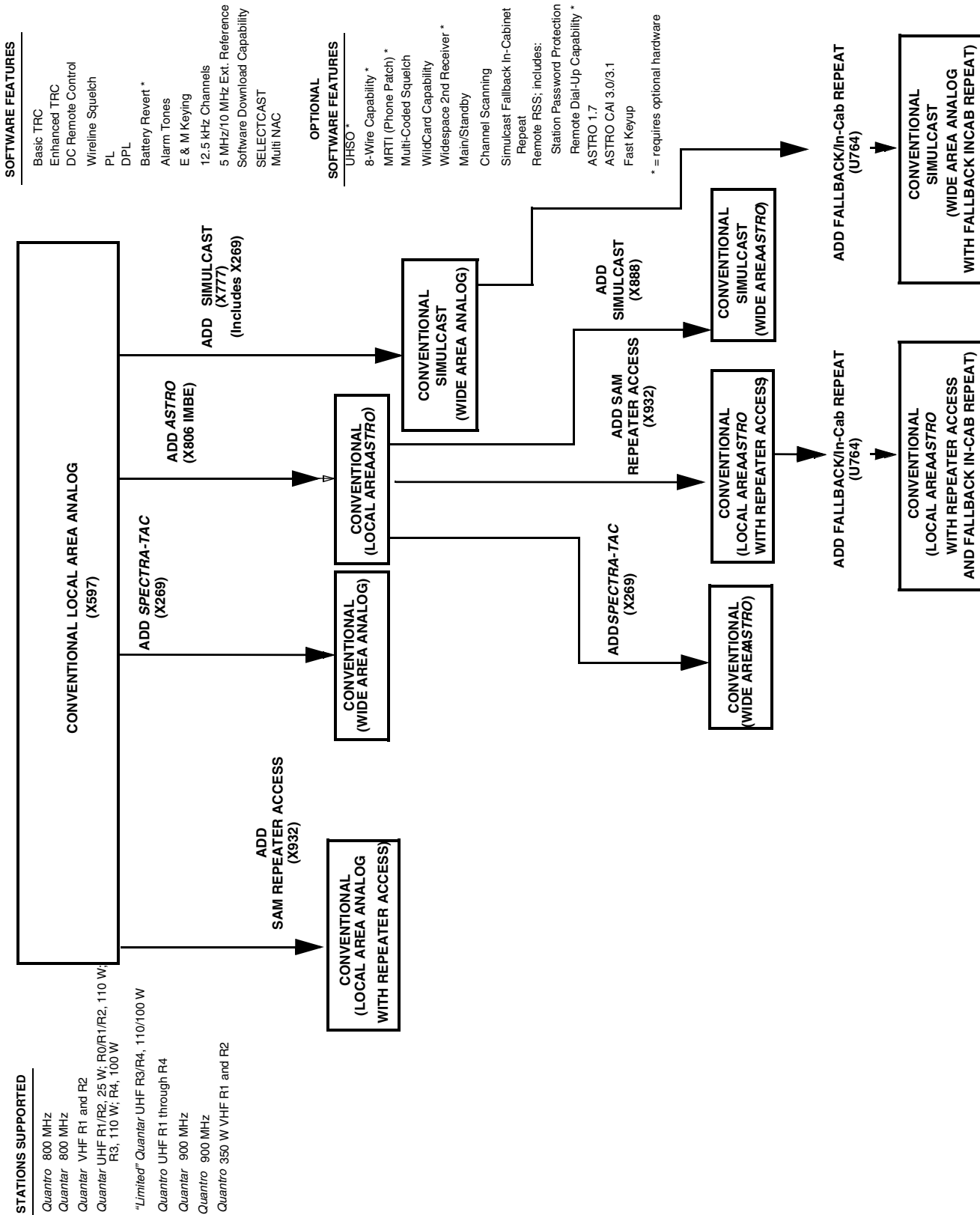


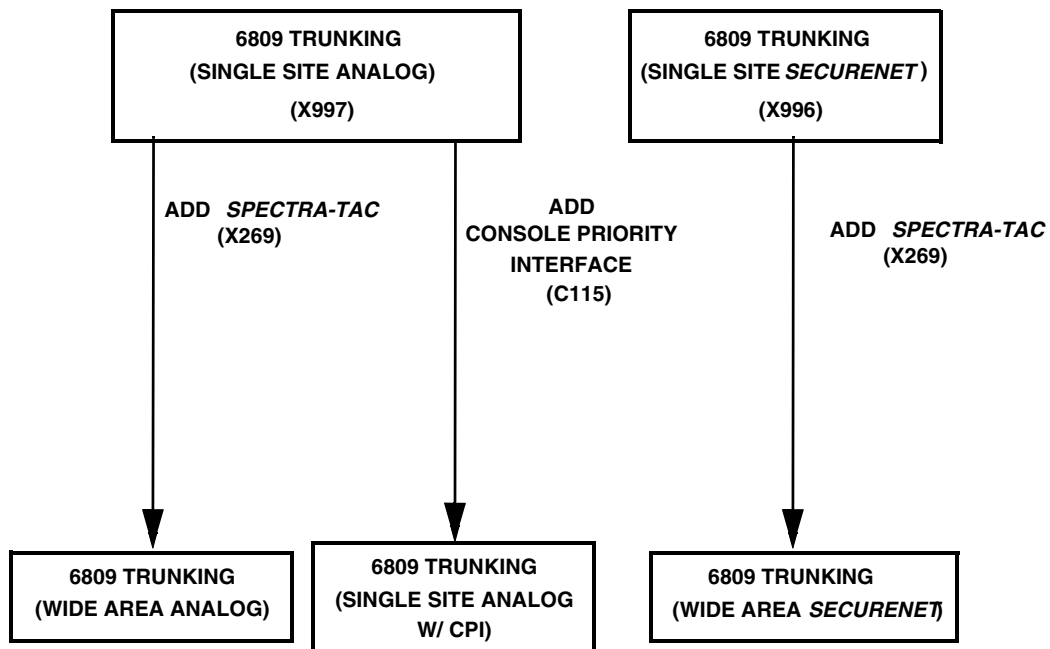
Figure 7-17 Release R14.0.00 Features and System Capabilities - Conventional

**STATIONS SUPPORTED**

Quantro 800 MHz  
 QUANTAR VHF R1 and R2  
 Quantro UHF R1 through R3  
 QUANTAR 900 MHz  
 Quantro 350 W VHF R1 and R2

**STANDARD SOFTWARE FEATURES**

Basic TRC  
 Battery Revert \*  
 12.5 kHz Channels  
 5 MHz External Reference  
 Failsoft  
 \* = requires optional hardware



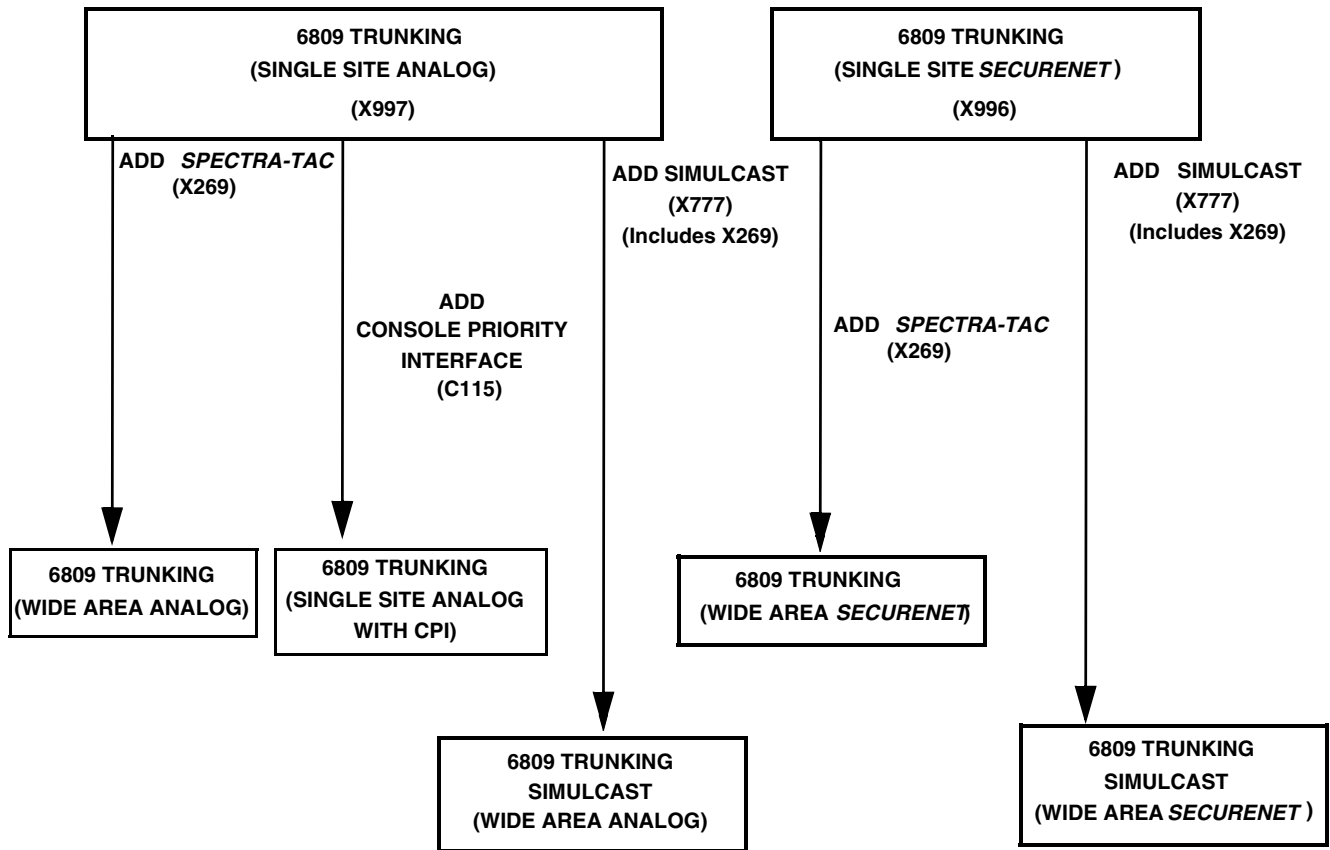
**Figure 7-18** Release R2.00 Features and System Capabilities - 6809 Trunking

**STATIONS SUPPORTED**

Quantro 800 MHz  
 QUANTAR VHF R1 and R2  
 Quantro UHF R1 through R3  
 QUANTAR 900 MHz  
 Quantro 350 W VHF R1 and R2

**STANDARD SOFTWARE FEATURES**

Basic TRC  
 Battery Revert \*  
 12.5 kHz Channels  
 5 MHz/10 MHz External Reference  
 UHSO\*  
 Failsoft  
 \* = requires optional hardware



**Figure 7-19** Release R3.00 / R3.01 Features and System Capabilities - 6809 Trunking

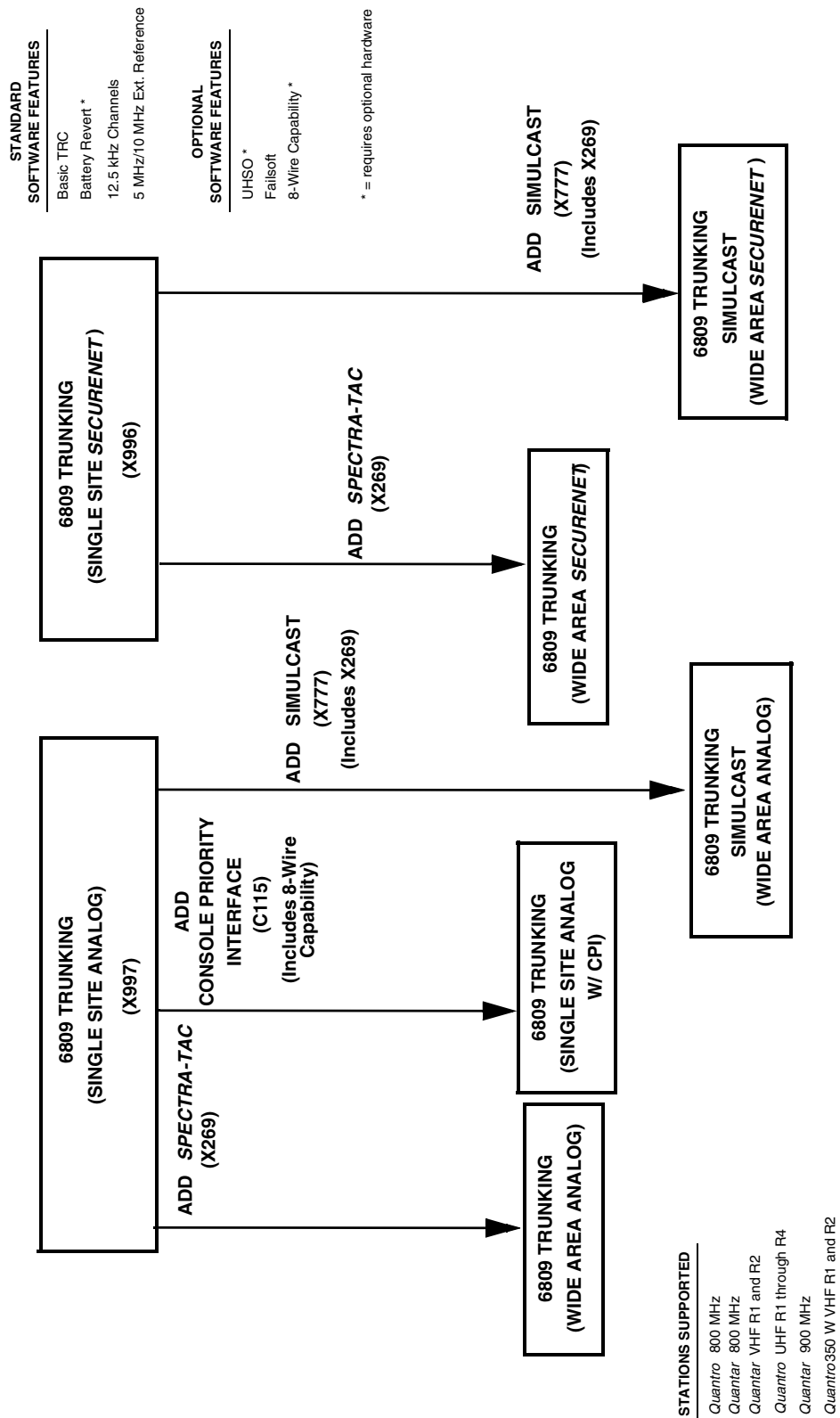


Figure 7-20 Release R4.00 Features and System Capabilities - 6809 Trunking

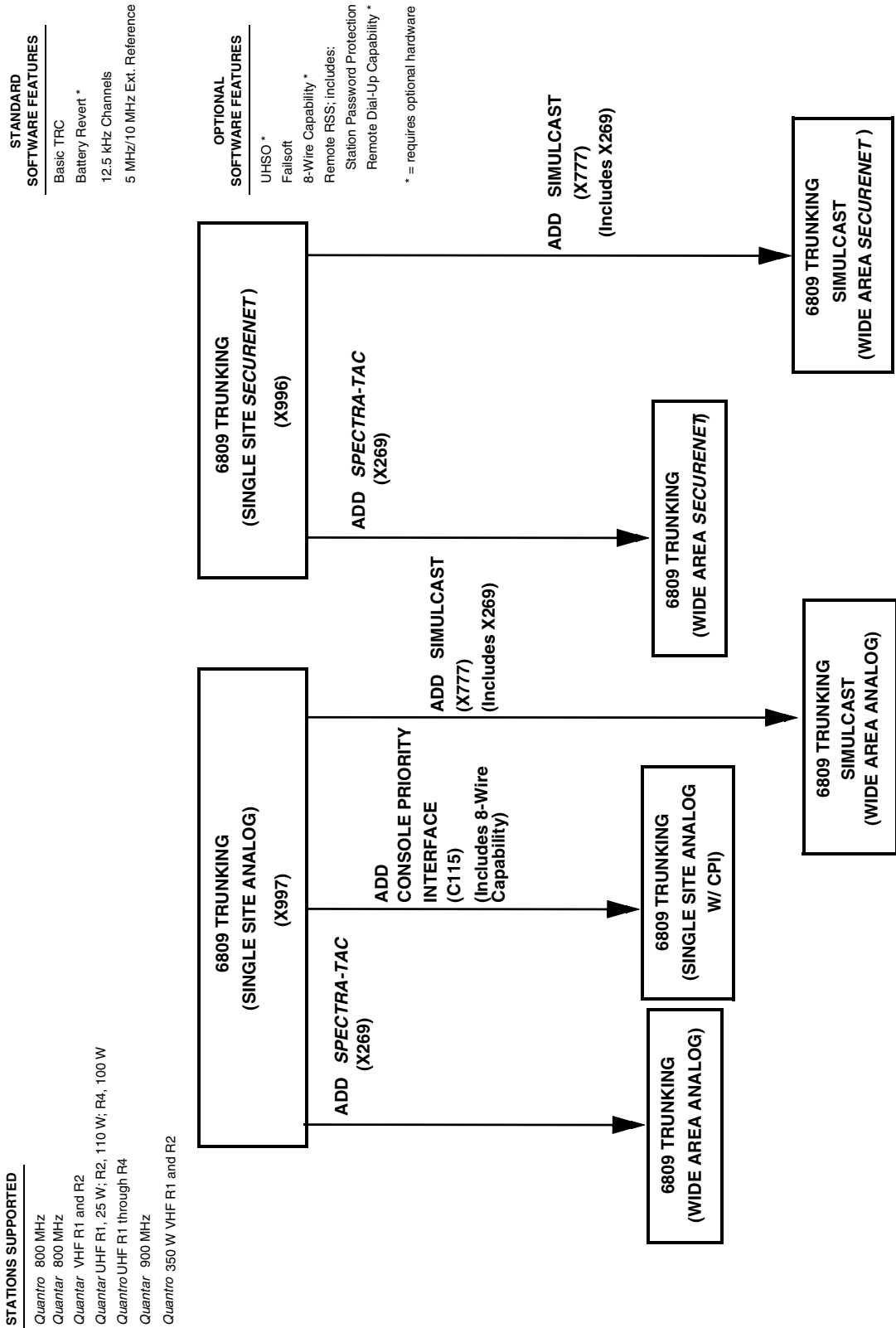


Figure 7-21 Release R5.00 Features and System Capabilities - 6809 Trunking



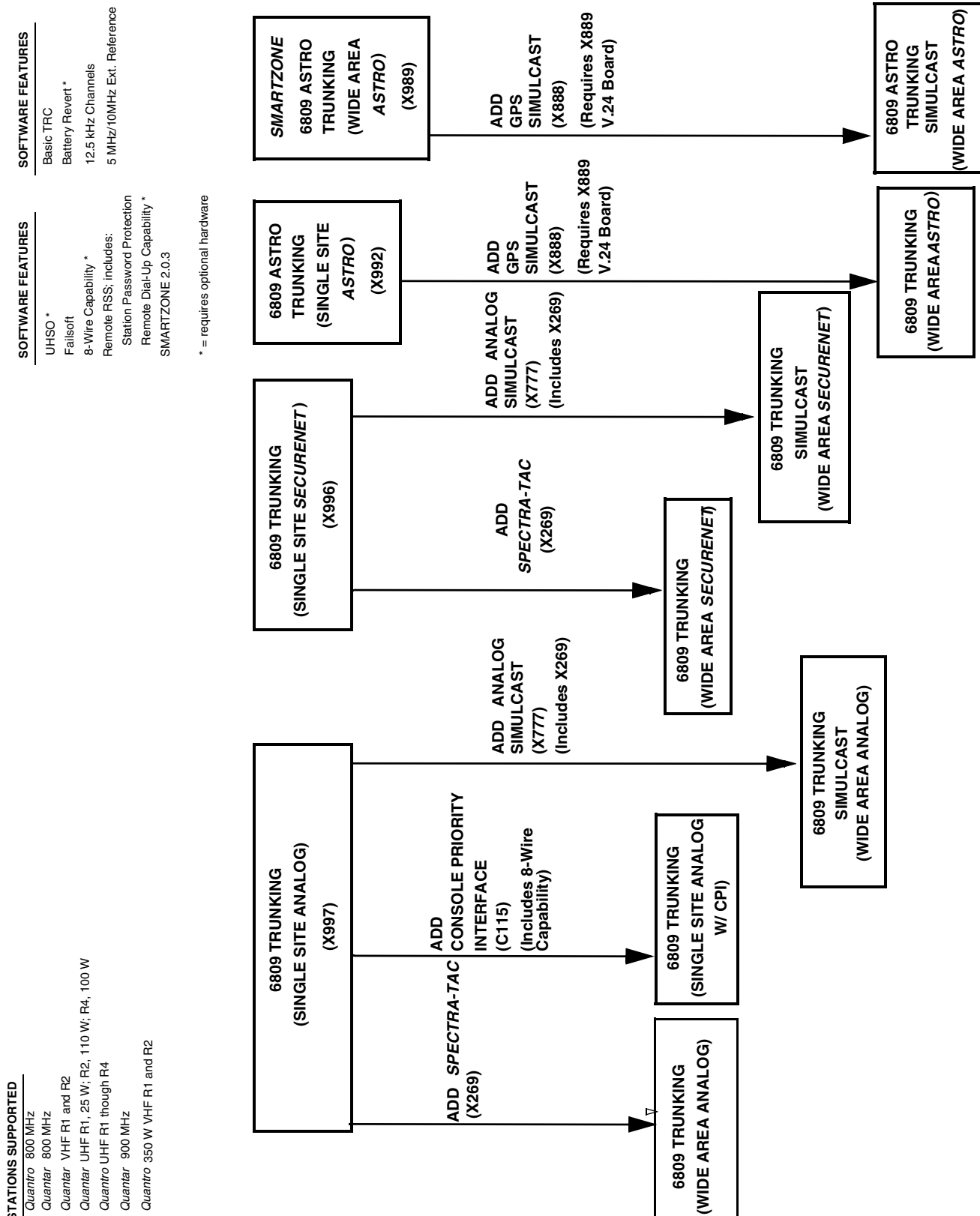


Figure 7-22 Release R6.00 Features and System Capabilities - 6809 Trunking

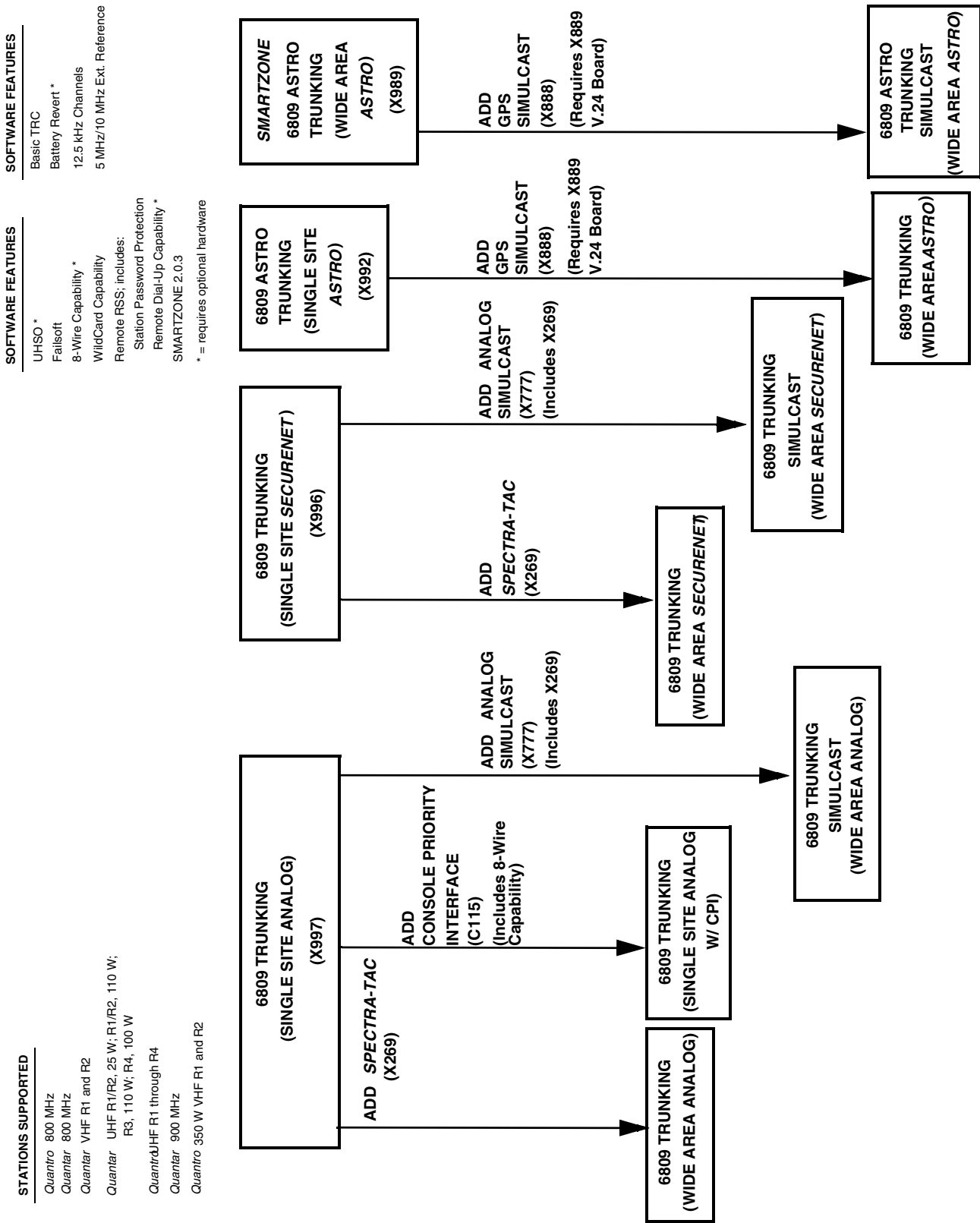


Figure 7-23 Release R7.00 Features and System Capabilities - 6809 Trunking

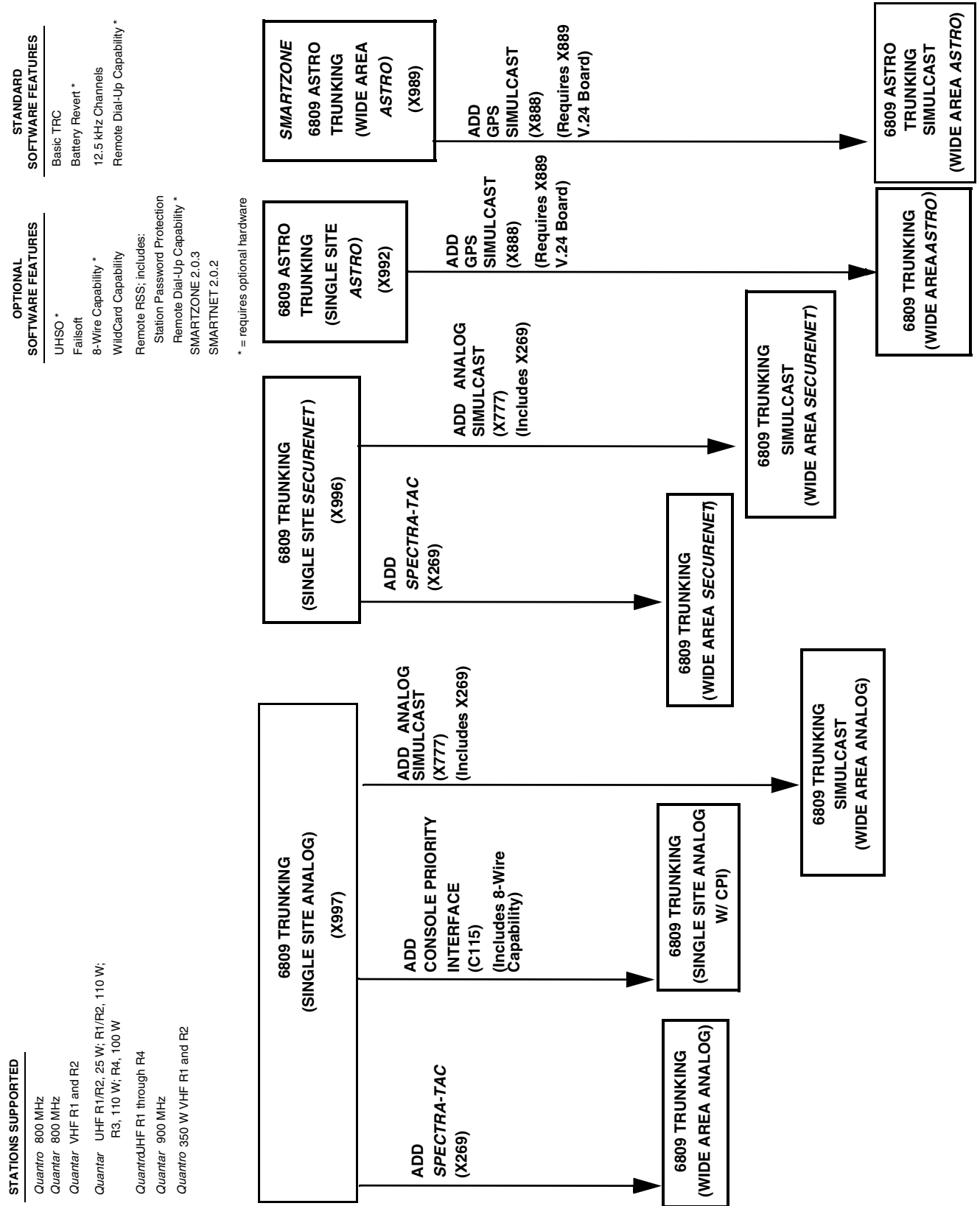


Figure 7-24 Release R07.02.02 Features and System Capabilities - 6809 Trunking

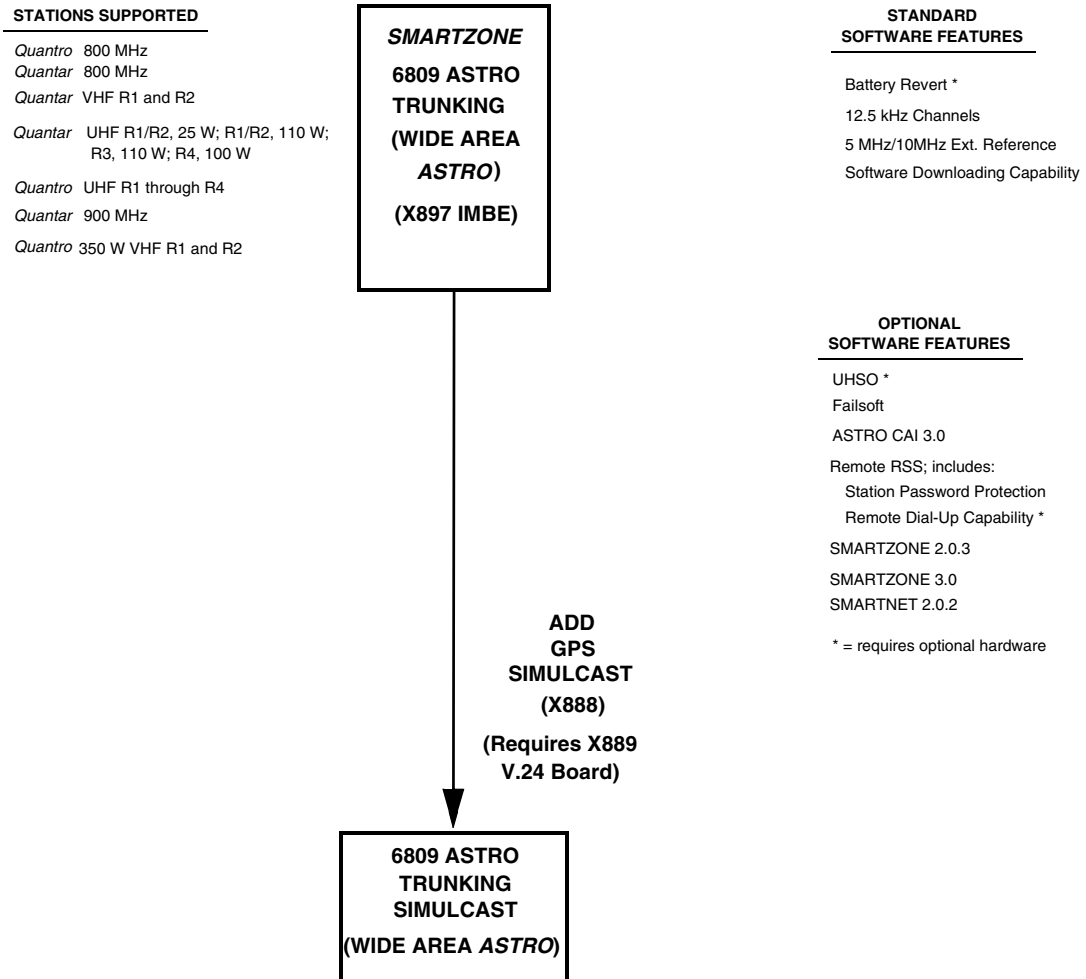


Figure 7-25 Release R09.00.00 Features and System Capabilities - 6809 Trunking

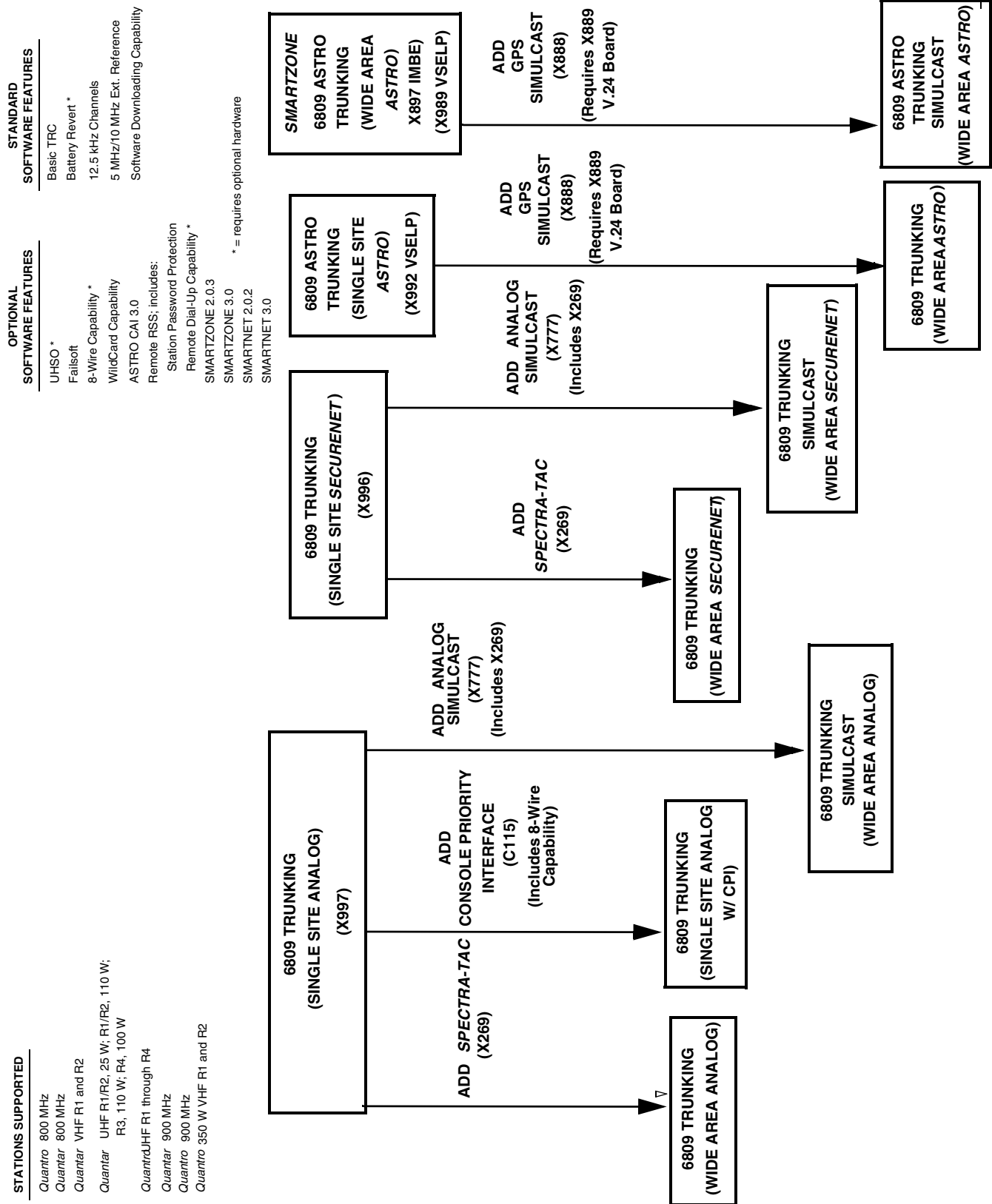


Figure 7-26 Release R09.02.01 Features and System Capabilities - 6809 Trunking

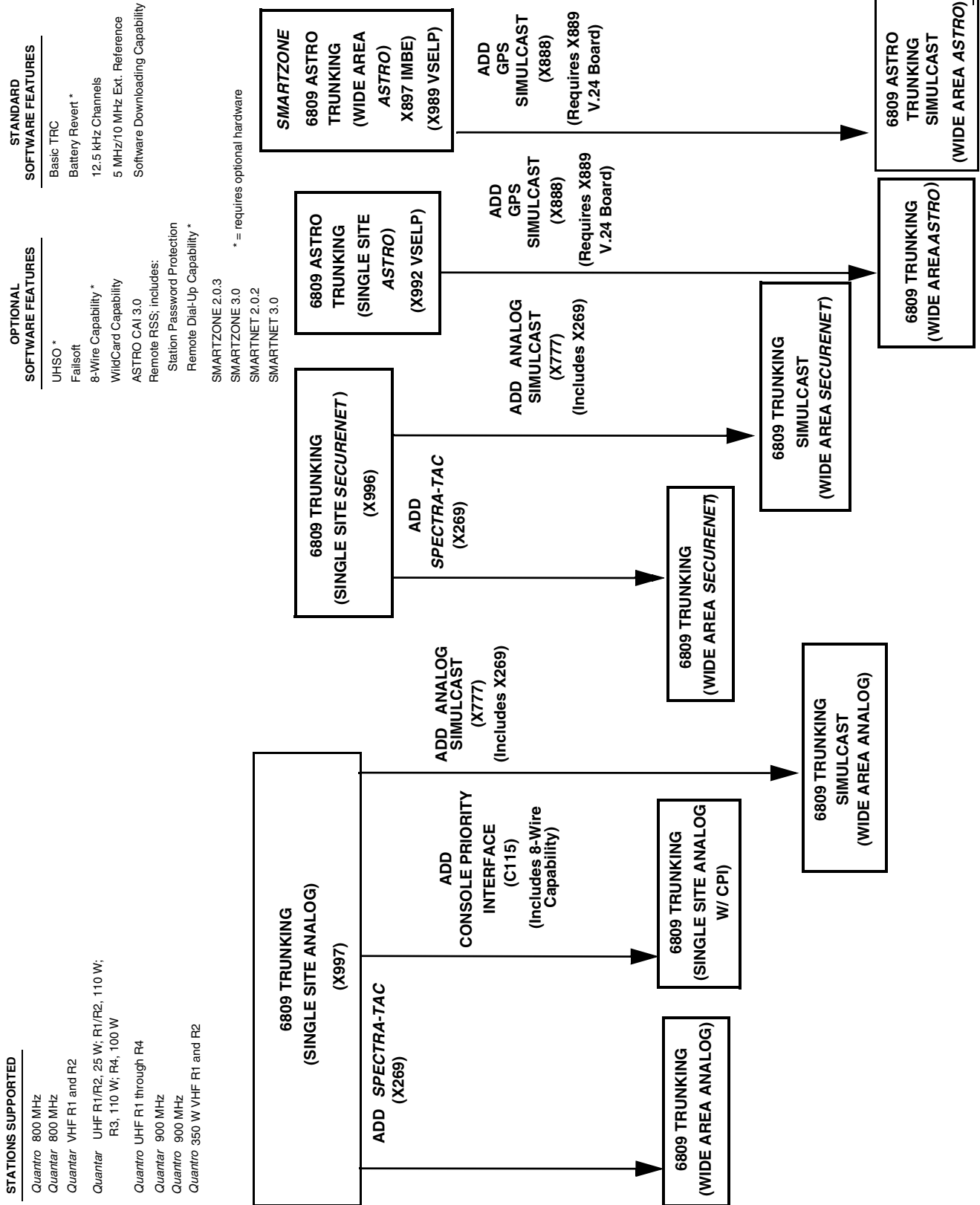
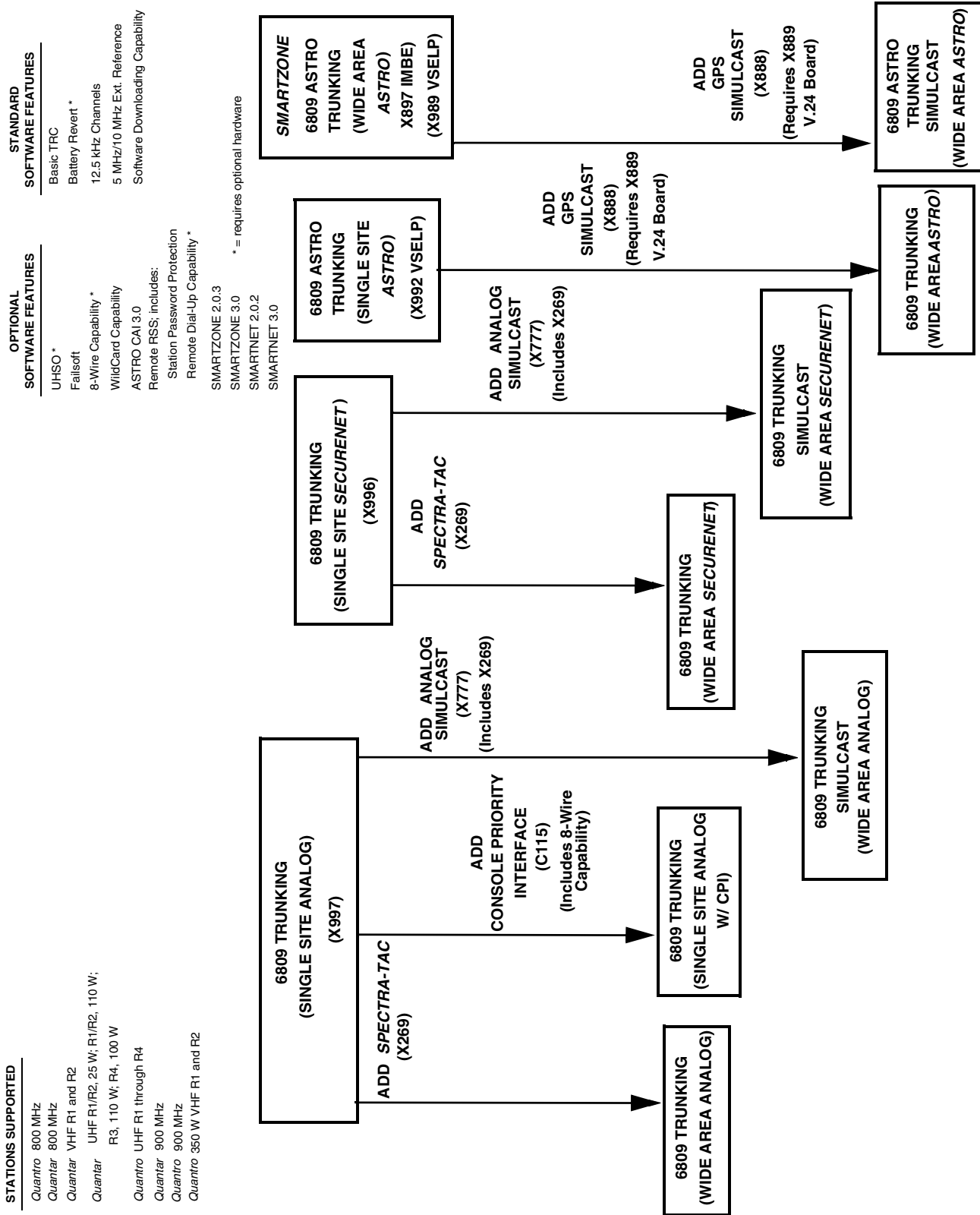


Figure 7-27 Release R09.03.00 Features and System Capabilities - 6809 Trunking



**Figure 7-28** Release R09.05.00/R09.06.00/R09.07.00/R10.00.00 through R10.08.00, R10.11.00, R10.12.00  
 Features and System Capabilities - 6809 Trunking

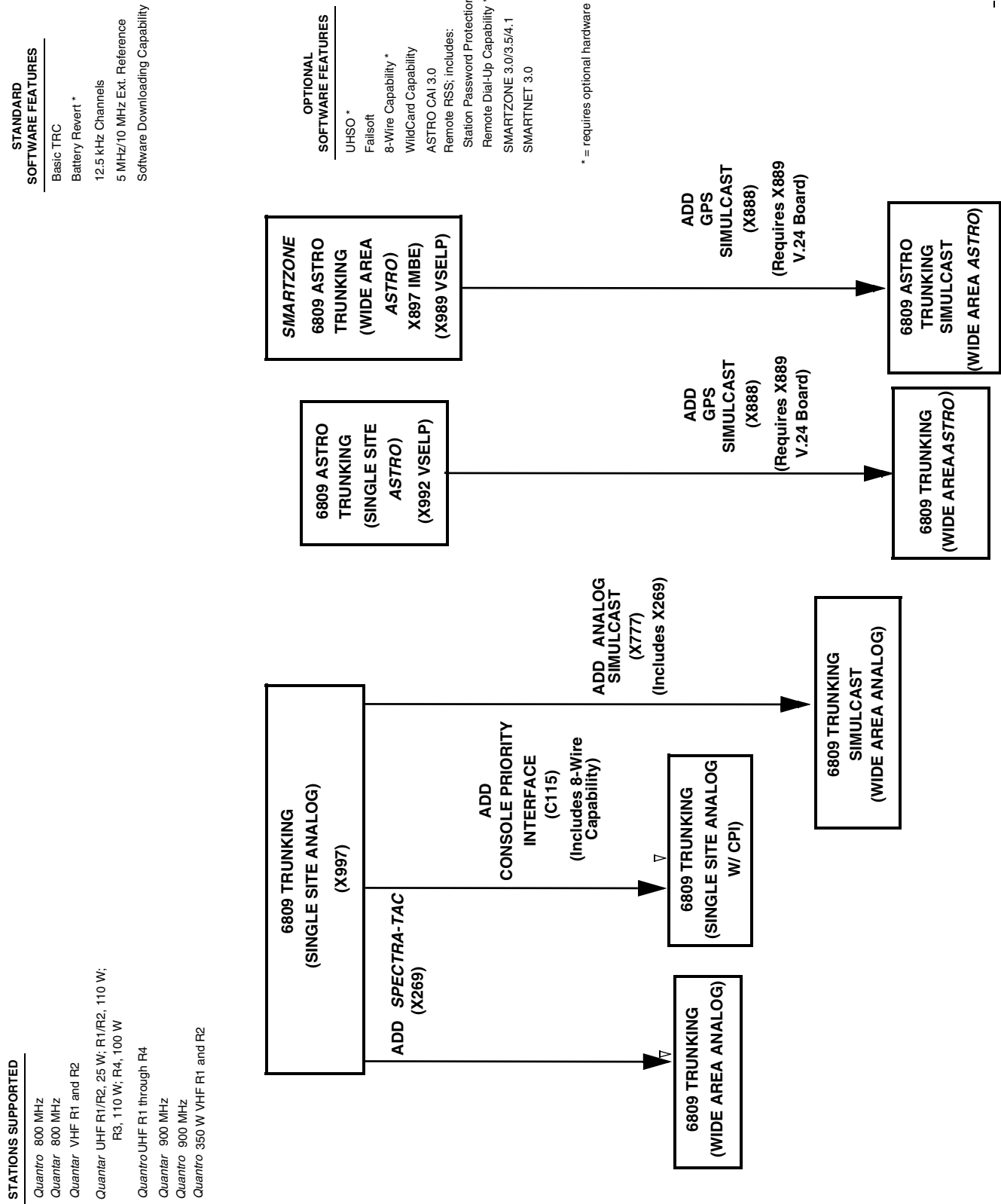


Figure 7-29 Release R12.01.00 through R12.03.00 Features and System Capabilities - 6809 Trunking



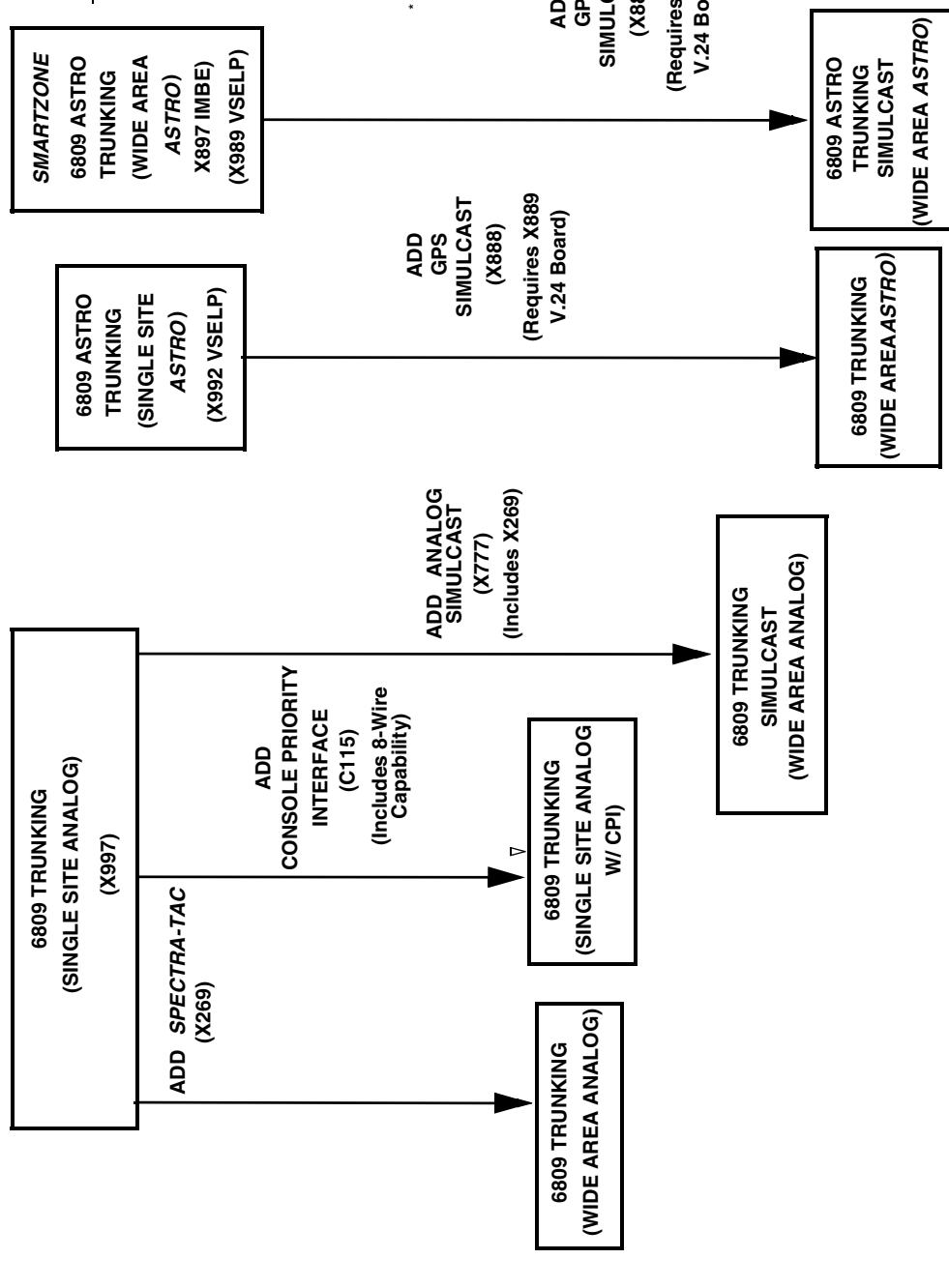
**STATIONS SUPPORTED**

- Quantro 800 MHz
- Quantar 800 MHz
- Quantar VHF R1 and R2
- Quantar UHF R1/R2, 25 W; R1/R2, 110 W; R3, 110 W; R4, 100 W
- Quantar UHF R1 through R4
- Quantro 900 MHz
- Quantro 900 MHz
- Quantro 350 W VHF R1 and R2

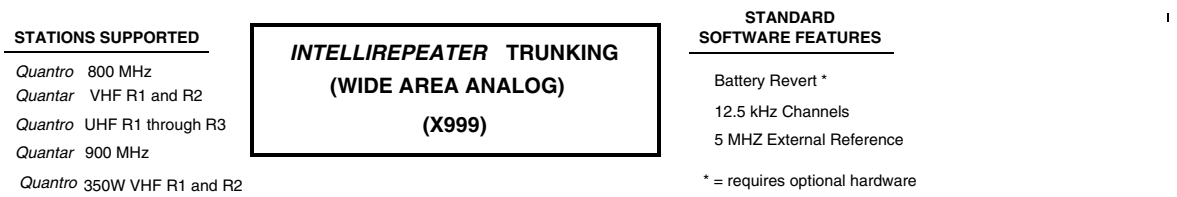
- STANDARD SOFTWARE FEATURES**
- Basic TRC
  - Battery Revert \*
  - 12.5 kHz Channels
  - 5 MHz/10 MHz Ext. Reference
  - Software Downloading Capability

- OPTIONAL SOFTWARE FEATURES**
- UHSO \*
  - Fallsort
  - 8-Wire Capability \*
  - WildCard Capability
  - ASTRO CAI 3.0
  - Remote RSS; includes: Station Password Protection
  - Remote Dial-Up Capability \*
  - SMARTZONE 3.0/3.5/4.1
  - SMARTNET 3.0

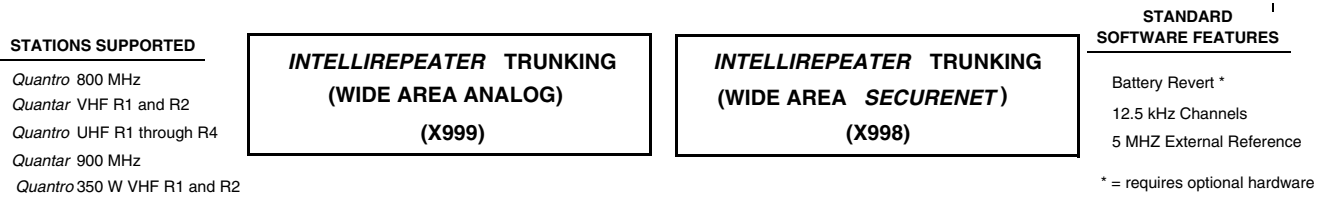
\* = requires optional hardware



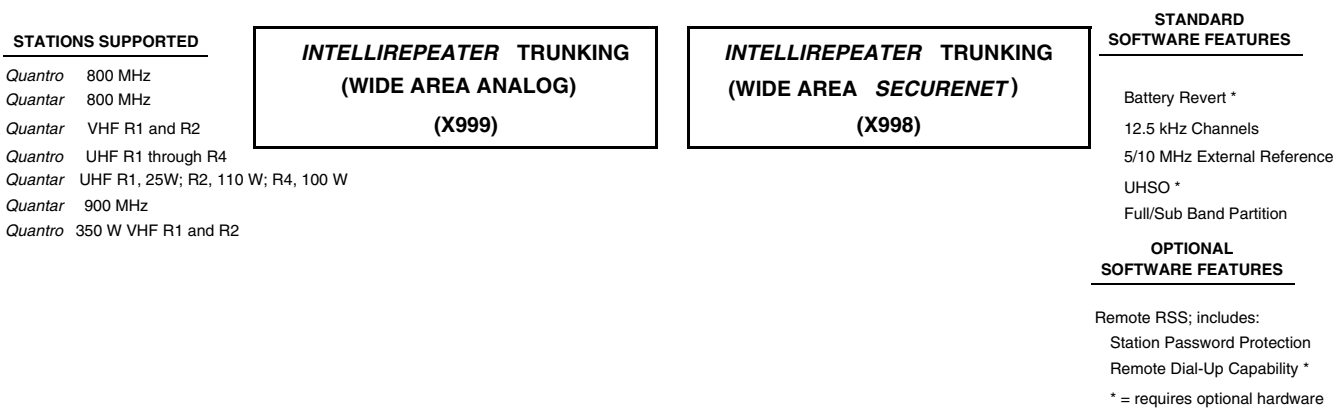
**Figure 7-30** Release R13.00.00 through R14.00.00 Features and System Capabilities - 6809 Trunking



**Figure 7-31** Release SZ2.0 Features and System Capabilities - IntelliRepeater Trunking



**Figure 7-32** Release SZ2.3 Features and System Capabilities - IntelliRepeater Trunking



**Figure 7-33** Release SZ2.7/2.7E Features and System Capabilities - IntelliRepeater Trunking

<u>STATIONS SUPPORTED</u>	<u>STANDARD SOFTWARE FEATURES</u>	<u>OPTIONAL SOFTWARE FEATURES</u>
<i>Quantro</i> 800 MHz		
<i>Quantar</i> 800 MHz		
<i>Quantar</i> VHF R1 and R2	Battery Revert *	Remote RSS; includes:
<i>Quantro</i> UHF R1 through R4	12.5 kHz Channels	Station Password Protection
<i>Quantar</i> UHF R1/R2, 25 W; R1/R2, 110W ; R3, 110 W; R4, 100 W	5/10 MHz External Reference	Remote Dial-Up Capability *
<i>Quantar</i> 900 MHz	UHSO *	
<i>Quantro</i> 350 W VHF R1 and R2	Full/Sub Band Partition	* = requires optional hardware

**SMARTZONE  
INTELLIREPEATER TRUNKING  
(WIDE AREA ANALOG)  
(X999)**

**SMARTZONE  
INTELLIREPEATER TRUNKING  
(WIDE AREA SECURENET)  
(X998)**

**SMARTZONE ASTRO  
INTELLIREPEATER TRUNKING  
(WIDE AREA ASTRO)  
(X990)**

**Figure 7-34** Release 12.00.00 through 12.02.00 Features and System Capabilities - IntelliRepeater SZ2.0.3 Trunking

<u>STATIONS SUPPORTED</u>	<u>SOFTWARE FEATURES</u>	<u>SOFTWARE FEATURES</u>
<i>Quantro</i> 800 MHz		
<i>Quantar</i> 800 MHz	Battery Revert *	Remote RSS; includes:
<i>Quantar</i> VHF R1 and R2	12.5 kHz Channels	Station Password Protection
<i>Quantro</i> UHF R1 through R4	5/10 MHz External Reference	Remote Dial-Up Capability *
<i>Quantar</i> UHF R1/R2, 25 W; R1/R2, 110 W; R3, 110 W; R4, 100W	UHSO *	SMARTZONE 3.0/3.5/4.1
<i>Quantar</i> 900 MHz	Full/Sub Band Partition	
<i>Quantro</i> 900 MHz	ASTRO CAI	* = requires optional hardware
<i>Quantro</i> 350 W VHF R1 and R2		

**SMARTZONE  
INTELLIREPEATER TRUNKING  
(WIDE AREA ANALOG)  
(X999)**

**SMARTZONE  
INTELLIREPEATER TRUNKING  
(WIDE AREA SECURENET)  
(X998)**

**SMARTZONE ASTRO CAI  
INTELLIREPEATER TRUNKING  
(WIDE AREA ASTRO CAI)  
(X898)**

Note SECURENET is not supported beginning 1/1/02.

**Figure 7-35** Release 12.00.00 through 12.02.00 Features and System Capabilities - IntelliRepeater SmartZone 3.0/3.5/4.1 Trunking

STATIONS SUPPORTED	SOFTWARE FEATURES	SOFTWARE FEATURES
<i>Quantro</i> 800 MHz <i>Quantar</i> 800 MHz <i>Quantar</i> VHF R1 and R2 <i>Quantro</i> UHF R1 through R4 <i>Quantar</i> UHF R1/R2, 25 W; R1/R2, 110 W; R3, 110 W; R4, 100 W  <i>Quantar</i> 900 MHz <i>Quantro</i> 900 MHz <i>Quantro</i> 350 W VHF R1 and R2	Battery Revert * 12.5 kHz Channels 5/10 MHz External Reference UHSO * Full/Sub Band Partition ASTRO CAI	Remote RSS; includes: Station Password Protection Remote Dial-Up Capability * SMARTZONE 3.0/3.5/4.1  * = requires optional hardware
<b>SMARTZONE INTELLIREPEATER TRUNKING (WIDE AREA ANALOG) (X999)</b>		<b>SMARTZONE ASTRO CAI INTELLIREPEATER TRUNKING (WIDE AREA ASTRO CAI) (X898)</b>

**Figure 7-36** Release 13.00.00 through 13.02.00 Features and System Capabilities - IntelliRepeater SmartZone 3.0/3.5/4.1 Trunking

STATIONS SUPPORTED	SOFTWARE FEATURES	SOFTWARE FEATURES
<i>Quantro</i> 800 MHz <i>Quantar</i> 800 MHz <i>Quantar</i> VHF R1 and R2 <i>Quantro</i> UHF R1 through R4 <i>Quantar</i> UHF R1/R2, 25 W; R1/R2, 110 W; R3, 110 W; R4, 100 W  <i>Quantar</i> 900 MHz <i>Quantro</i> 900 MHz <i>Quantro</i> 350 W VHF R1 and R2	Battery Revert * 12.5 kHz Channels 5/10 MHz External Reference UHSO * Full/Sub Band Partition ASTRO CAI	Remote RSS; includes: Station Password Protection Remote Dial-Up Capability * SMARTZONE 3.0/3.5/4.1  * = requires optional hardware
<b>SMARTZONE INTELLIREPEATER TRUNKING (WIDE AREA ANALOG) (X999)</b>		<b>SMARTZONE ASTRO CAI INTELLIREPEATER TRUNKING (WIDE AREA ASTRO CAI) (X898)</b>

**Figure 7-37** Release 14.00.00 Features and System Capabilities - IntelliRepeater SmartZone 3.0/3.5/4.1 Trunking

STATIONS SUPPORTED	SOFTWARE FEATURES	SOFTWARE FEATURES
<i>Quantro</i> 800 MHz <i>Quantar</i> 800 MHz <i>Quantar</i> VHF R1 and R2 <i>Quantro</i> UHF R1 through R4 <i>Quantar</i> UHF R1/R2, 25 W; R0/R1/R2, 110 W; R3, 110 W; R4, 100 W  <i>Quantar</i> 900 MHz <i>Quantro</i> 900 MHz <i>Quantro</i> 350 W VHF R1 and R2	Battery Revert * 12.5 kHz Channels 5/10 MHz External Reference UHSO * Full/Sub Band Partition ASTRO CAI	Remote RSS; includes: Station Password Protection Remote Dial-Up Capability * SMARTZONE 3.0/3.5/4.1  * = requires optional hardware
<b>SMARTZONE INTELLIREPEATER TRUNKING (WIDE AREA ANALOG) (X999)</b>		<b>SMARTZONE ASTRO CAI INTELLIREPEATER TRUNKING (WIDE AREA ASTRO CAI) (X898)</b>

**Figure 7-38** Release 14.02.00 Features and System Capabilities - IntelliRepeater SmartZone 3.0/3.5/4.1 Trunking

**STATIONS SUPPORTED**

*Quantro* 800 MHz  
*Quantar* 800 MHz  
*Quantar* VHF R1 and R2  
*Quantro* UHF R1 through R4  
*Quantar* UHF R1/R2, 25 W; R1/R2, 110 W;  
 R3, 110 W; R4, 100 W  
*Quantar* 900 MHz  
*Quantro* 350 W VHF R1 and R2

**STANDARD SOFTWARE FEATURES**

Battery Revert \*  
 12.5 kHz Channels  
 5/10 MHz External Reference  
 UHSO \*  
 Full/Sub Band Partition  
 800 MHz Rebanding

**OPTIONAL SOFTWARE FEATURES**

Remote RSS; includes:  
 Station Password Protection  
 Remote Dial-Up Capability \*

\* = requires optional hardware

**SMARTZONE  
 INTELLIREPEATER TRUNKING  
 (WIDE AREA ANALOG)  
 (X999)**

**SMARTZONE  
 INTELLIREPEATER TRUNKING  
 (WIDE AREA SECURENET)  
 (X998)**

**SMARTZONE ASTRO  
 INTELLIREPEATER TRUNKING  
 (WIDE AREA ASTRO)  
 (X990)**

**Figure 7-39** Release 14.00.00 Features and System Capabilities - IntelliRepeater SmartZone 2.0.3 Trunking

**THIS PAGE INTENTIONALLY LEFT BLANK.**

# Password Protection

---

QUANTAR and Quantro stations are equipped with a password protection feature that limits RSS access to the station by unauthorized personnel. Stations that are password protected prohibit any RSS action requiring communications with the station until the station password is entered.

## How Password Protection Works

---

On a station with password protection activated, any attempted RSS action that requires communication with the station, such as reading the station codeplug, results in a password popup that prompts you to enter the station password.

When the correct password is entered, the current RSS session may proceed until the session is terminated by the user, or until the station is reset. The next RSS session requires the password to be entered.

## Password Time-out

If the RSS remains idle for 10 minutes without user activity, an internal station timer expires, requiring the user to re-enter the password. You may bypass the password for the current RSS session by performing the procedure “Bypassing the Station Password” on page 8-6.

## Activating Password Protection

Stations are shipped from the factory without a default password, and can therefore be accessed by any user with a compatible release of RSS software. To activate password protection, you must access **Tools** then **Set device password** and establish an initial password.

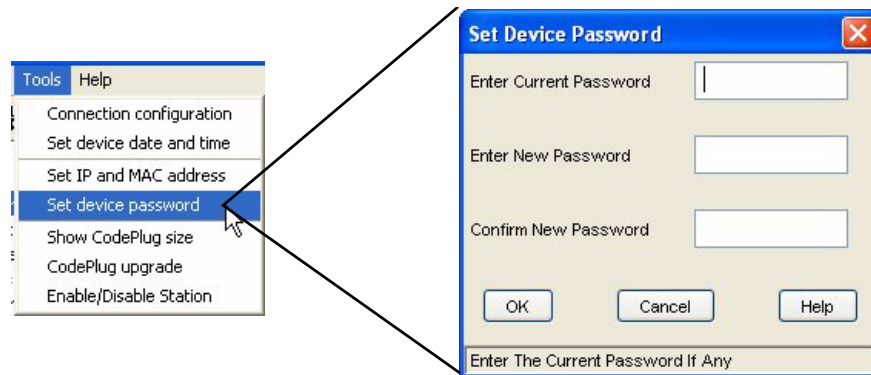
## Special Password Protection Features

The password protection feature allows a forgotten password to be erased, as well as temporary circumvention of the current password, leaving the current password valid. These features are described in this chapter.

## Creating the Station's Password

To create a station password (for stations with either no prior password or an erased password), perform the procedure below:

1. Connect the RSS computer to the station.
2. Launch RSS and connect to the station.
3. From the **Tools** menu, select **Set device password**. The Set Device Password window appears.



4. Leave the **Enter Current Password** field blank (it currently has no password).
5. Enter the new password in the **Enter New Password** field.
6. Enter the new password in the **Confirm New Password** field.
7. Click **OK**. If the passwords entered in the **Enter New Password** and **Confirm New Password** fields match, then the new password is saved. If the passwords do not match, the following warning window appears and you must re-enter the new password.





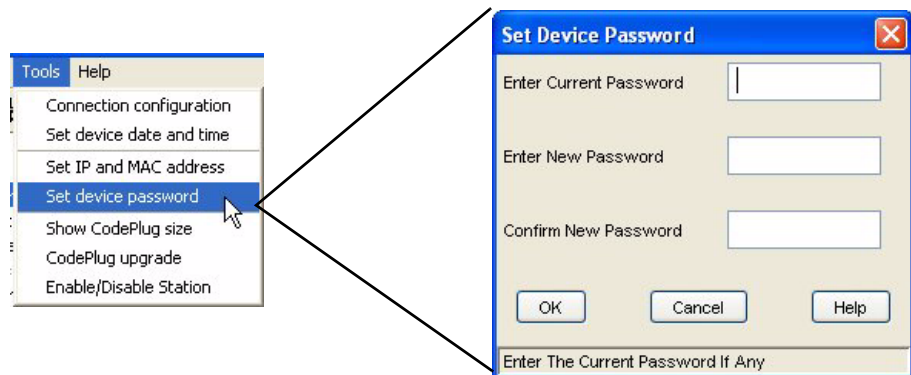
## Changing Station Password

To change an existing station password, perform the procedure below:

1. Connect the RSS computer to the station.
2. Launch RSS and connect to the station.
3. From the **Tools** menu, select **Set device password**. The Station Password Prompt window appears.



4. Enter the current password.
5. Click **OK**. The Set Device Password window appears.



6. Enter the current password in the **Enter Current Password** field.
7. Enter the new password in the **Enter New Password** field.
8. Enter the new password in the **Confirm New Password** field.
9. Click **OK**. If the passwords entered in the **Enter New Password** and **Confirm New Password** fields match, then the new password is saved. If the passwords do not match, the following warning window appears and you must re-enter the new password.



## Erasing Station Password (Local Access)

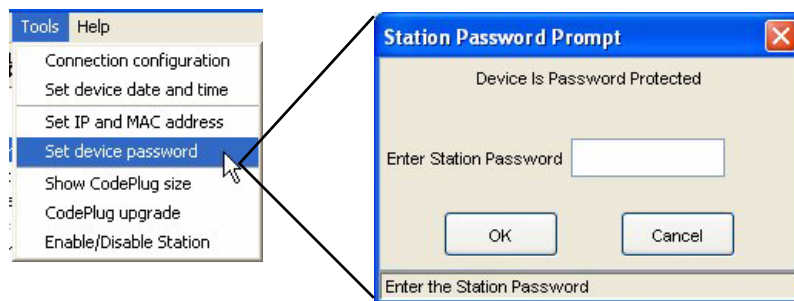


### NOTE

If the password is erased, all future RSS sessions (local or remote) are allowed without requiring a password. You may create another password by following the instructions on page “Creating the Station’s Password” on page 8-2.

If you wish to erase the current station password, if for example you have forgotten it, and are physically at the station site, perform the procedure below:

1. Connect the RSS computer to the station.
2. Launch RSS and connect to the station.
3. From the **Tools** menu, select **Set device password**. The Station Password Prompt window appears.



4. Type **lost** in the **Enter Station Password** field.

5. Press and hold the **Vol Up** and **Vol Down** pushbuttons on the Station Control front panel. While holding the pushbuttons in, click **OK** on the Station Password Prompt window. The station password is permanently erased.

## Erasing Station Password (Remote Access)

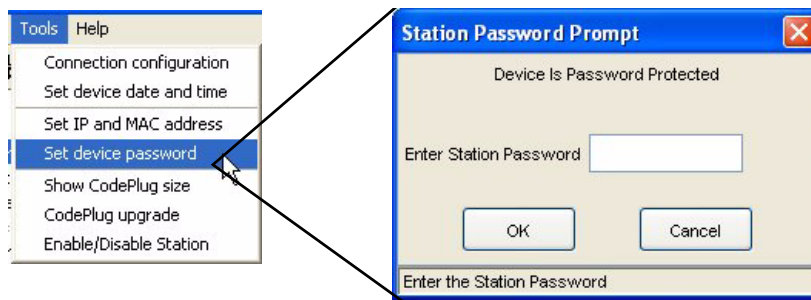


### NOTE

If the password is erased, all future RSS sessions (local or remote) are allowed without requiring a password. You may create another password by following the instructions on page “Creating the Station’s Password” on page 8-2.

If you know the station password and are connected to the station through a remote dial-up connection, you may erase the current station password by performing the procedure below:

1. Connect the RSS computer to a modem.
2. Launch RSS and dial in to the station.
3. From the **Tools** menu, select **Set device password**. The Station Password Prompt window appears.



4. Enter the current password.
5. Click **OK**. The Set Device Password window appears.



6. Type the current password in the **Enter Current Password** field.
7. Do not enter a password. Instead, click **OK**. The RSS information window appears indicating that password protection has been disabled.



8. Click **OK** to close the window.

## Bypassing the Station Password

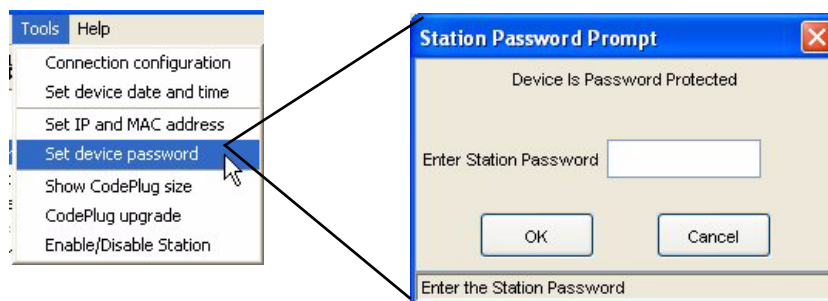
If you wish to temporarily bypass the station password, perform the procedures below. After the password has been bypassed, the current RSS session allows the RSS to operate as if you had entered the station password. When the RSS session is terminated, or the station is reset, password protection is again activated using the current password.



### NOTE

You need not know the current station password to perform this procedure. However, you must be physically at the station site.

1. Connect the RSS computer to a modem.
2. Launch RSS and connect to the station.
3. From the **Tools** menu, select **Set device password**. The **Station Password Prompt** window appears.



4. Type service in the **Enter Station Password** field.

5. Press and hold the **Vol Up** and **Vol Down** pushbuttons on the station control front panel. While holding the pushbuttons in, click **OK**. The station password is bypassed. The RSS operates as if you had entered the current station password.

**NOTE**

The time-out feature is still operational; if the 10 minute timer expires, you must repeat the password bypass procedure.

**THIS PAGE INTENTIONALLY LEFT BLANK.**

# Remote Dial-Up



QUANTAR and Quantro stations support remote dial-up capability. This feature allows the service technician to make a dial-up connection through a modem to a station and perform RSS tasks. See Figure 9-1 for an example of a typical dial-up connection between a PC and a remotely located station.



**NOTE**

See the modem manufacturer's instructions for information connecting the modem to your computer.

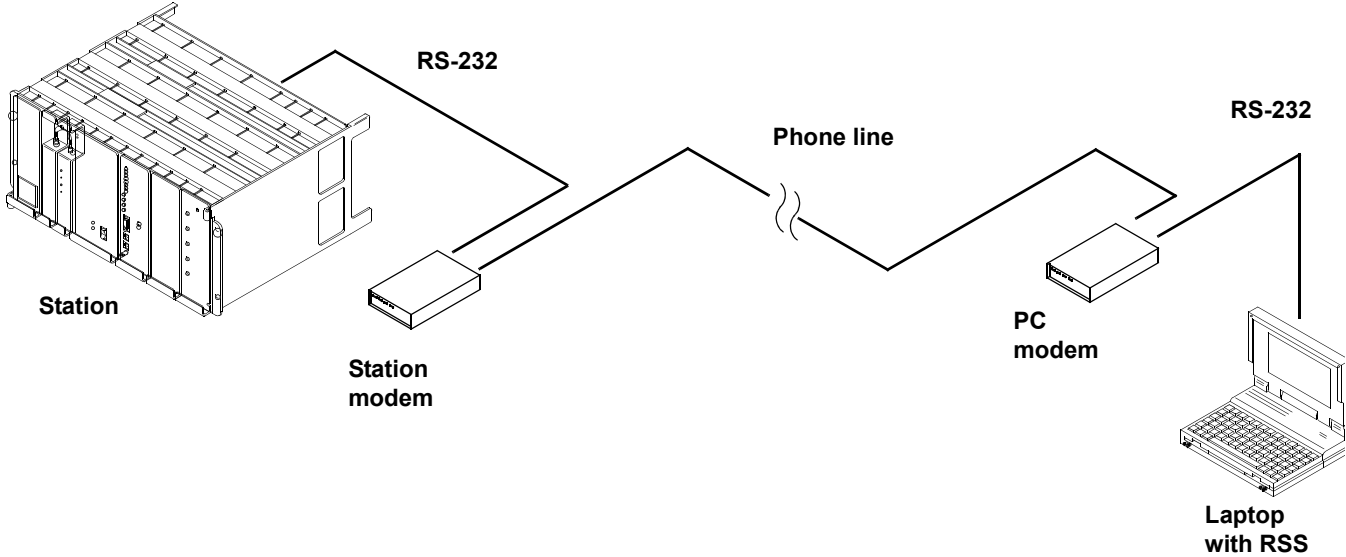


Figure 9-1 Remote Dial-Up Connection

## Modem Requirements

---

Two modems are required for a dial-up connection. One modem should have been installed at the station's location and is part of the system. The other modem is connected between your RSS PC and the land line. Although the figure shows a stand-alone modem, this modem can be installed in the laptop. If the modem is part of the RSS PC, the modem's drivers and communications program (such as Hyperterminal) must be installed on the PC and the operating system set up properly for modem operation. See the documentation accompanying the modem and the operating system's documentation for information on installing and configuring the modem. Listed below are the requirements for modems for use with QUANTAR and Quantro stations:

- Hayes-compatible computer interface
- V.32 (9600 bps) protocol
- If error correction and/or data compression are desired, all connected modems must employ the same scheme
- Station modem must be configured for auto-answer

## Station Modem Configuration

---

The station must be configured with the proper settings to allow communications with the PC modem. Configuration requires that a PC running a communications program be connected to the modem and commands be entered to program the desired settings. The following procedure provides the configuration for the communications program that is to control the modem:

1. Temporarily connect the station's modem to the RSS PC.
2. Launch the communications program (such as ProComm or Hyperterminal). See the program's manual or help file if required.
3. Enter the following command to program the modem settings for the factory defaults:

```
AT&F<return>
```

4. Enter the following command string to program the modem for the recommended configuration settings:

```
ATE0Q1&D0&K0N0S37=9S0=1<return>
```

Where:

- AT: Attention
- E0: Character echoing disabled



- Q1: Result code transmission disabled
  - &D0: Ignore DTR
  - &K0: XON/XOFF disabled (RTS/CTS) disabled
  - N0S37=9S0=1: 9600 bps connections only
  - S0=1: Auto-answer after 1 ring
5. Enter AT&W0&Y0<return> command to store the configuration settings in modem memory and to instruct the modem to load these settings on modem power up.

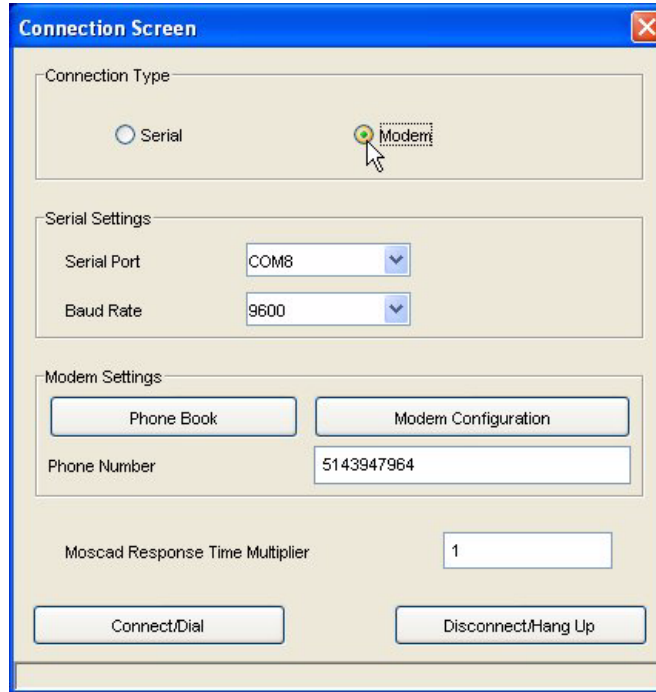
## PC Modem Configuration

---

Programming the configuration settings for the PC modem is accomplished using the RSS program (release 5.00 or higher). The RSS provides a modem configuration screen that includes an initialization string sent to the PC modem on initiation of a remote session with a station. This string programs the PC modem for proper operation. The screen also contains additional fields to allow related modem configuration parameters to be programmed.

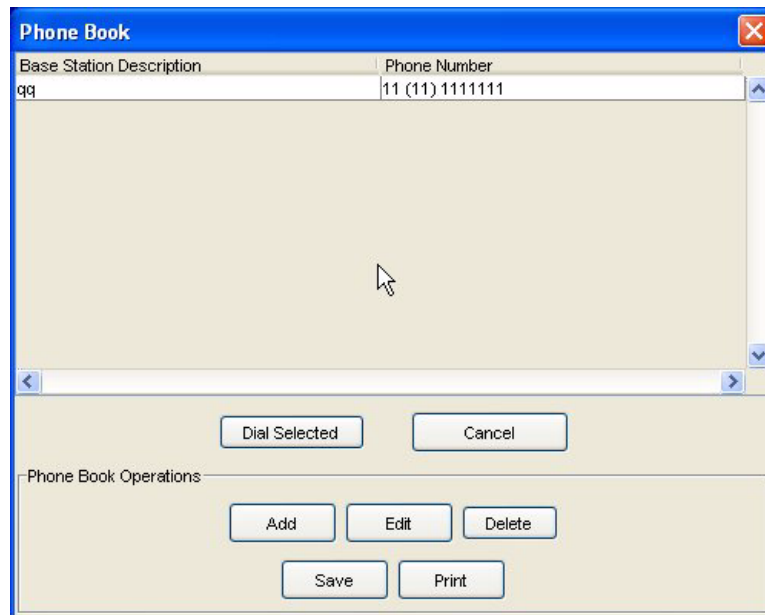
To configure the PC's modem through the RSS Modem Configuration screen, perform the following procedure:

1. Launch the RSS program.
2. From the **Tools** menu, select **Configure Connection**. The Configure Connection window appears.
3. Click **Modem**.



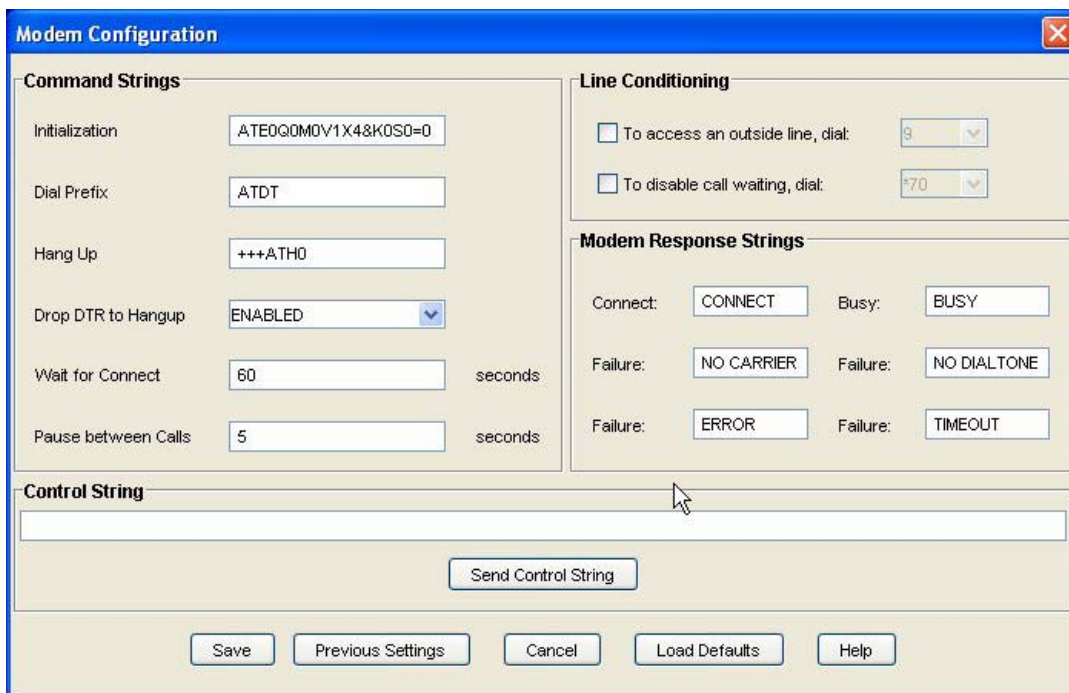
The screen changes to provide modem configuration controls.

4. Click **Phone Book**. The Phone Book window appears.



5. Enter the dial-up phone numbers for the sites where the stations are installed and provide an obvious description for each number, such as the site identifier.
6. Click **Save** when done.

7. Click **Modem Configuration**. The Modem Configuration window appears.



8. Configure the fields in this window as required. See Table 9-1.

**Table 9-1 RSS PC Modem Configuration Data Fields**

Data Fields	Description	Valid Range/ Selections	Default	Recommended Setting (if any)
<b>Command Strings</b>				
Initialization	Command string sent to PC modem on initiating a remote dial-up connection.	N/A	ATE1Q0V1X4&K0S 0=0^M	Default command string designed for most Hayes compatible modems. If default fails, try modem factory settings (AT&F^M), or refer to modem user guide.
Dial Prefix	Specifies the dialing method (pulse or tone).	ATDT: Tone dialing ATDP: Pulse dialing	ATDT	System dependent
Dial Suffix	Specifies the character that signifies the end of the dialing string.	^M: Carriage return	^M	System dependent
Hang-up	Specifies the command string sent to hang up the modem.	N/A	+++~ ~ ~ ATH0^M	Default is Hayes compatible

**Table 9-1 RSS PC Modem Configuration Data Fields (continued)**

Data Fields	Description	Valid Range/ Selections	Default	Recommended Setting (if any)
Drop DTR to hang-up	Specifies whether modem pulls RS-232 DTR line low when hanging up.	Enabled Disabled	Enabled	System dependent
Wait for Connect	Specifies the maximum length of time modem attempts to successfully connect to a remote modem before RSS hangs up and retries (see Pause between Calls).	1 to 999 seconds	60 seconds	Determined by user. Ensure value is less than <b>time to wait for carrier after dial S</b> - register setting (internal to modem). Refer to the modem user guide.
Pause between CALLS	Specifies the amount of time before RSS redials after an unsuccessful connection attempt.	1 to 999 seconds	5 seconds	Determined by user
<b>Modem Response Strings for</b>				
Connect	Specifies the key word in modem status message that indicates a successful connection.	N/A	Connect	Default is Hayes compatible. Otherwise, refer to modem user guide.
Busy	Specifies the key word in modem status message that indicates called modem phone is busy.	N/A	Busy	Default is Hayes compatible. Otherwise, refer to modem user guide.
Failure	Specifies the key word in modem status message that indicates no carrier signal from called modem.	N/A	No Carrier	Default is Hayes compatible. Otherwise, refer to modem user guide.

**Table 9-1 RSS PC Modem Configuration Data Fields (continued)**

<b>Data Fields</b>	<b>Description</b>	<b>Valid Range/ Selections</b>	<b>Default</b>	<b>Recommended Setting (if any)</b>
Failure	Specifies the key word in modem status message that indicates no dial tone on phone line.	N/A	No Dialtone	Default is Hayes compatible. Otherwise, refer to modem user guide.
Failure	Specifies the key word in modem status message that indicates some form of communications error has occurred.	N/A	Error	Default is Hayes compatible. Otherwise, refer to modem user guide.
Failure	Specifies the key word in modem status message that indicates exceeded time-out threshold (internal to modem) occurred between dialing and carrier detect.	N/A	Time-out	Default is Hayes compatible. Otherwise, refer to modem user guide.

**THIS PAGE INTENTIONALLY LEFT BLANK.**

# WildCard Operation

---

This chapter describes the operation of the WildCard option and how to make the various settings to implement custom WildCard functions. The WildCard option is a purchasable option that can be enabled on any QUANTAR or Quantro station or QUANTAR or ASTRO-TAC receiver. The WildCard option provides a powerful, user-friendly tool that is used to initiate specific functions whenever certain specific conditions are met. The relationship between the function that is executed and the conditions that initiate it is specified in the WildCard Action Table, which contains two sections:

- One specifies the conditions
- One specifies the function or action to execute

The section that contains the conditions allows the programmer to specify up to three states/inputs and two Boolean functions that tie the states/input together and to determine the functions to execute. The station continuously evaluates the states and inputs specified using the Boolean operators to determine when the condition, as evaluated through the Boolean logic statement, is true or false. When the condition becomes true, the commands specified in the Action Table are executed in sequential order. When the condition becomes false, the commands specified in the Inaction Table are executed in sequential order. Commands are executed only when conditions change. If conditions do not change, commands are not executed.

WildCard functions may be created to provide simple monitoring tasks, such as causing the station to generate a tone over the wireline when Battery Revert becomes true, to complex tasks, such as the Main/Standby feature which requires multiple tables to implement.

In general, using the WildCard option is comprised of the following three major steps:

1. Configure station auxiliary inputs
  - Configure inputs into binary groups for external channel or access code table control
  - Configure individual inputs
2. Configure station auxiliary outputs
  - Configure outputs into binary groups for reporting of station channel, MCS user information, or access code table control
  - Configure individual outputs
3. Configure state/action tables
  - Modify default state/action tables to accommodate unique system requirements
  - Generate new state/action tables to implement new WildCard functions

## Station Auxiliary Inputs

---

Each QUANTAR and Quantro station and QUANTAR Receiver contains circuitry located on the wireline interface board that can accept TTL inputs and relay closures (AUX Inputs) from miscellaneous external equipment. Two types of inputs are provided:

- Opto-coupled
- Transistor

These are available through the 50-pin system connector located on the station backplane.

For normal operation (without WildCard option), many of these inputs have predefined functions, as described in the *Backplane* section of the appropriate *QUANTAR or Quantro Station Functional Manual* or *QUANTAR Receiver Functional Manual*. However, with the WildCard Option available and enabled through the RSS, the function of each predefined input and each undefined input, may be customized, usually to implement one or more WildCard functions.

An additional feature is the ability to select predefined combinations of inputs (binary groups). When used with a properly programmed WildCard Function, this feature facilitates binary control of the station by an external source, such as the console, to control the station operating channel or select an Access Code Table. For example, Binary Group 1 is comprised of station inputs 1, 2, 3, and 4, and may be used to allow the station operating channel to be set according to the binary state of the four inputs, for example 0010 sets the station to Channel 2.

## Programming the WildCard Input Screen

A common application of the station inputs is allowing external equipment, usually a console, to control the current station channel number and/or the access code table number to be used by the station. To facilitate these applications, the **WildCard Input** screen provides the ability to select predefined groups of inputs whose binary values determine the station channel or access code table. Alternatively, in order to provide maximum flexibility in designing WildCard Functions, the inputs may also be configured individually.

To access the WildCard Input screen, click **WildCard Input** in the navigation pane. Figure 10-1 shows representative WildCard screens (Enhanced selected in the Hardware Configuration screen). The figure shows two views: one where the **Binary Groups** are set to **None** and the other when inputs are specified. Table 10-1 provides descriptions of the provided fields.



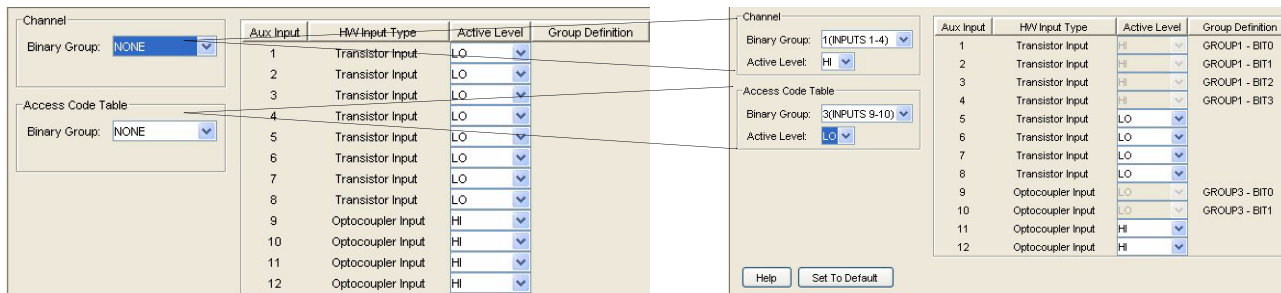


Figure 10-1 WildCard Input Screen - Enhanced Shown

Table 10-1 WildCard Input Screen Data Fields

Data Field	Description	Range/Selections	Default	Recommended Setting (if any)
Channel Binary Group	Used to select one (or None) of the pre-defined “binary groups” used to select Access Code Table (overriding ACT programmed for channel in Channel Information screen).	<ul style="list-style-type: none"> <li>• None</li> <li>• 1 (Inputs 1-4)</li> <li>• 2 (Inputs 1-8)</li> <li>• 3 (Inputs 9-10)</li> <li>• 4 (Inputs 9-12)</li> <li>• 5 (Inputs 5-8)</li> </ul>	None	System dependent
Access Code Table Binary Group	Used to select one (or None) of the pre-defined “binary groups” used to control station operating channel.	<ul style="list-style-type: none"> <li>• None</li> <li>• 1 (Inputs 1-4)</li> <li>• 2 (Inputs 1-8)</li> <li>• 3 (Inputs 9-10)</li> <li>• 4 (Inputs 9-12)</li> <li>• 5 (Inputs 5-8)</li> </ul>	None	System dependent
Active Level	If a binary group is selected, active level (HI or LO) is chosen here; applies to all inputs of selected binary group.	<ul style="list-style-type: none"> <li>• Hi</li> <li>• Lo</li> </ul>	N/A	System dependent
Aux Input	Station Aux Inputs listed here; correspond to AUX IN 1-12 inputs shown for 50-pin System Connector in Backplane section of appropriate QUANTAR or Quantro Station Functional Manual, or example AUX IN 7.	1-12 for enhanced 1-9 for basic	N/A	Dependent on whether basic or enhanced WildCard is selected

**Table 10-1** WildCard Input Screen Data Fields (continued)

Data Field	Description	Range/Selections	Default	Recommended Setting (if any)
HW Input Type	Specifies hardware circuitry (located on Wireline Interface Board) associated with input.	<ul style="list-style-type: none"> <li>• Basic and Enhanced:               <ul style="list-style-type: none"> <li>• 1-8: Transistor</li> </ul> </li> <li>• Basic:               <ul style="list-style-type: none"> <li>• 9: Opto-coupler</li> </ul> </li> <li>• Enhanced:               <ul style="list-style-type: none"> <li>• 9-12: Opto-coupler</li> </ul> </li> </ul>	<ul style="list-style-type: none"> <li>• Basic and Enhanced:               <ul style="list-style-type: none"> <li>• 1-8: Transistor</li> </ul> </li> <li>• Basic:               <ul style="list-style-type: none"> <li>• 9: Opto-coupler</li> </ul> </li> <li>• Enhanced:               <ul style="list-style-type: none"> <li>• 9-12: Opto-coupler</li> </ul> </li> </ul>	Dependent on whether basic or enhanced WildCard is selected.
Active Level	Indicates current active level for each input; may be set for HI or LO.	<ul style="list-style-type: none"> <li>• Transistor: Hi/Lo</li> <li>• Opto-coupler: Hi/Lo</li> </ul>	<ul style="list-style-type: none"> <li>• Transistor: Lo</li> <li>• Opto-coupler: Hi</li> </ul>	System dependent
Group Definition	Defines binary bit “ranking” for binary groups. Bit 0 is LSB and Bit 3 is MSB.			

## Station Auxiliary Outputs

Each QUANTAR and Quantro station and QUANTAR Receiver contains circuitry located on the wireline interface board that provides auxiliary outputs (AUX Outputs) to control miscellaneous external equipment. Two types of outputs are provided:

- Transistor
- Relay closure

These are available through the 50-pin System Connector located on the station backplane.

For normal operation (without WildCard Option), many of these outputs have pre-defined functions, as described in the *Backplane* section of the appropriate QUANTAR or Quantro Station *Functional Manual*. However, with the WildCard Option available and enabled through the RSS, the function of each pre-defined output, as well as each undefined output, may be customized (usually to implement one or more WildCard Functions).

An additional feature is the ability to select pre-defined combinations of outputs (binary groups). When used with a properly programmed WildCard Function, this feature allows the station to report to external equipment (such as a console), the current station operating channel, Access Code Table, or MCS user. For example, Binary Group 1 is comprised of station outputs 1, 2, 3, and 4, and may be used to allow the station to report the current operating channel to external equipment, such as a console. For example, 0010 reports that the station is currently operating on Channel 2.

## Programming the Wildcard Output Screen

This screen is available when the WildCard Option is set to either Basic or Enhanced on the Hardware Configuration screen. To access the **WildCard Output** screen, click **WildCard Output** in the navigation pane, see Figure 10-2. See Table 10-2 for the screen's data fields.

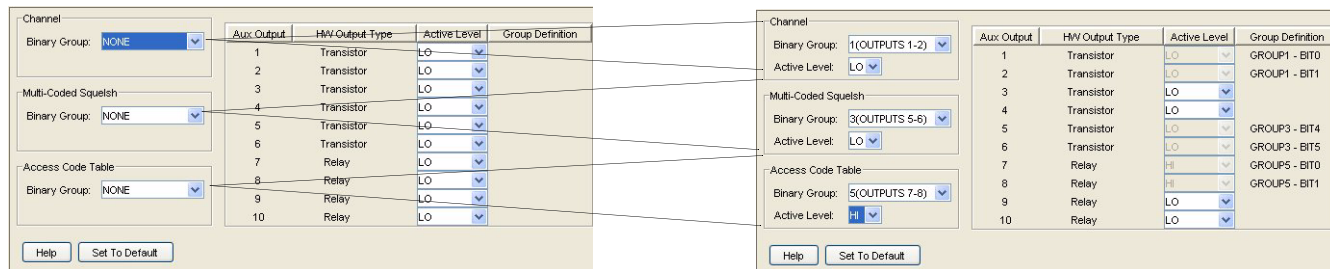


Figure 10-2 WildCard Output Screen - Enhanced Shown

Table 10-2 WildCard Output Screen Data Fields

Data Field	Description	Range/Selections	Default	Recommended Setting (if any)
Channel Binary Group	Used to select one (or None) of the pre-defined binary groups used to report station operating channel.	<ul style="list-style-type: none"> <li>None</li> <li>1 (Inputs 1-4)</li> <li>2 (Inputs 1-8)</li> <li>3 (Inputs 9-10)</li> <li>4 (Inputs 9-12)</li> <li>5 (Inputs 5-8)</li> </ul>	None	System dependent
Multi Code Squelch Table Binary Group	Used to select one (or None) of the pre-defined binary groups used to report MCS users.	<ul style="list-style-type: none"> <li>None</li> <li>1 (Inputs 1-4)</li> <li>2 (Inputs 1-8)</li> <li>3 (Inputs 9-10)</li> <li>4 (Inputs 9-12)</li> <li>5 (Inputs 5-8)</li> </ul>	None	System dependent
Access Code Table Binary Group	Used to select one (or None) of the pre-defined binary groups used to report Access Code Table.	<ul style="list-style-type: none"> <li>None</li> <li>1 (Inputs 1-4)</li> <li>2 (Inputs 1-8)</li> <li>3 (Inputs 9-10)</li> <li>4 (Inputs 9-12)</li> <li>5 (Inputs 5-8)</li> </ul>	None	System dependent
Aux Output	Station Aux Outputs listed here; correspond to AUX OUT (#) outputs shown for 50-pin System Connector in backplane section of appropriate QUANTAR or Quantro Station Functional Manual (for example, AUX OUT 7).	1-12 for enhanced 1-9 for basic	N/A	Dependent on whether basic or enhanced WildCard is selected

**Table 10-2** WildCard Output Screen Data Fields (continued)

Data Field	Description	Range/Selections	Default	Recommended Setting (if any)
HW Input Type	Specifies hardware circuitry (located on wireline interface board) associated with output.	<ul style="list-style-type: none"> <li>• Basic and Enhanced:</li> <li>• 1-3: Transistor</li> <li>• Basic:</li> <li>• 7: Relay</li> <li>• Enhanced:</li> <li>• 7-10: Relay</li> </ul>	<ul style="list-style-type: none"> <li>• Basic and Enhanced:</li> <li>• 1-3: Transistor</li> <li>• Basic:</li> <li>• 7: Relay</li> <li>• Enhanced:</li> <li>• 7-10: Relay</li> </ul>	Dependent on whether basic or enhanced WildCard is selected
Active Level	Indicates current active level for each output; may be set for HI or LO.	<ul style="list-style-type: none"> <li>• Hi</li> <li>• Lo</li> </ul>	<ul style="list-style-type: none"> <li>• Transistor: Lo</li> <li>• Relay: Lo</li> </ul>	System dependent
Group Definition	Defines binary bit "ranking" for binary groups. Bit 0 is LSB and Bit 1 is MSB.	•		

## State/Action Tables

The State/Action Tables screen(s) provides a powerful interface that allows custom WildCard functions to be created or existing WildCard Functions to be modified. Implementing WildCard functions using the State/Action Tables ranges from simple single action tables to complex multiple action tables.

A common application of the station outputs is to provide external monitoring equipment with indications of the current station channel, Access Code Table, and/or MCS users. To facilitate these applications, the Output Configuration screen provides the ability to select pre-defined groups of outputs whose binary values indicate the station channel, access code table, or MCS users. Alternatively, in order to provide maximum flexibility in designing WildCard functions, the outputs may also be configured individually.

Three binary group programming areas are provided on the WildCard Input screen, one for Channel Binary Group, one for ACT Binary Group, and one for MCS Binary Group. These areas are used to program the pre-defined input combinations (binary group) which is used to indicate the external equipment of the channel, ACT, and/or MCS users. Each may be programmed independently.



**CAUTION**

While the State/Action Tables feature provides a powerful, flexible method of creating and modifying WildCard Functions, there is also the increased risk of misprogramming which can result in infinite loops, inadvertently resetting the station, and other unintentional station behavior. Please exercise caution when defining the inputs and outputs, and when configuring the State/Action Tables.



**IMPORTANT**

If WildCard and SECURENET features are both enabled, Output 2 must remain active LO and cannot be used in any other WildCard table, either as an individual output or as part of a Binary Group.

## How State/Action Tables Operate

Whenever a state changes from True to Untrue, the state/condition statement, in **State and Condition Settings** are evaluated from left to right with no parentheses. If the logical result changes from Untrue to True, the command(s) in the **Action** list is executed by the station. If the list contains more than one command, the commands are executed sequentially. All commands in the list are executed even if the logical result of the state/condition evaluation becomes untrue during performance of the sequence.

If the result changes from true to untrue, the command(s) in the **Inaction** list is executed by the station. If the list contains more than one command, the commands are executed sequentially. All commands in the list are executed even if the logical result of the state/condition evaluation becomes true during performance of the sequence.

The figure below shows a simple example: When Input 2 (TX Inhibit) becomes true (logic HI, as defined in the **WildCard Input** screen), the TX INHIBIT command in the **Action** list is executed by the station. The station transmitter is now inhibited and remains so until the condition becomes untrue (logic LO), at which time the command in the **Inaction** list is executed. The station transmitter is now enabled and remains so until the condition again becomes true.

## Programming the Wildcard State Screen

This screen is available when the WildCard Option is set to either **Basic** or **Enhanced** on the **Hardware Configuration** screen. Each station equipped with the WildCard Option comes programmed with a default set of **State/Action Tables** that provide a basic set of station functions, such as Ext PTT, RX Code Det, or RD Stat. The default tables utilize the predefined functions assigned to the station auxiliary inputs and outputs, as described in the *Backplane* section of the appropriate QUANTAR or Quantro station or QUANTAR receiver *Functional Manual*. The number of default tables depends on the station type: conventional or 6809 trunking.

You may use the default tables as provided, modify one or more to satisfy unique customer requirements, or add tables (thus adding WildCard functions).

The Action and Inaction lists provide up to XX fields for entering commands.



### IMPORTANT

It is important to remember that for any given state change, the command list in each and every **State/Action Table** containing the state change in the **State/Condition** string is executed. Be very careful when designing WildCard functions to consider the impact of commands in a given **State/Action Table** with all other **State/Action Tables**, even tables that do not relate specifically to the same WildCard function.

To access the WildCard State screen, click WildCard State in the navigation pane, see Figure 10-2. See Table 10-2 for the screen's data fields.

Description: POWER UP      TABLE 1 OF 14      Jump to Table: 1

State And Condition Settings

State: COLD RESET      Cond: OR      State: WARM RESET      Cond:      State:

Action

CLR OUTPUT	1
CLR EVENT FLAG	1
SET EVENT FLAG	2
RXDSC-AUXRX ON	

Inaction

NULL	

Buttons: Help, Add Table, Set To Default, Previous Table, Next Table, Delete Table, Programming Rules

Figure 10-3 WildCard State Screen

**Table 10-3** WildCard State/Action Screen Data Fields

Data Field	Description	Range/Selections	Default	Recommended Setting (if any)
Description	Indicates the name assigned to the WildCard Function implemented by this table. Enter text using keyboard (14 alphanumeric characters max).	Up to 15 alpha-numeric characters	Blank	System dependent
Table	Indicates the current table number and shows total number of tables currently implemented.	Up to XX tables	1	System dependent
Jump to Table	Enter desired table number and press <b>Enter</b> key to display corresponding table.	Up to the number of configured tables	1	System dependent
State Field	Defines a station state that is used to determine an action.	Provided in selection list	Blank	System dependent
Condition Field	Determines the boolean operation performed on the selected states.	<ul style="list-style-type: none"> <li>• AND</li> <li>• AND NOT</li> <li>• OR</li> <li>• OR NOT</li> </ul>	Blank	System dependent
Action	Action list contains commands which are executed sequentially (top to bottom) when the state/condition settings change from untrue to true.	Provided in selection list	Blank	
Inaction	Inaction list contains commands which are executed sequentially (top to bottom) when the state/condition settings change from true to untrue.	Provided in selection list	Blank	

**THIS PAGE INTENTIONALLY LEFT BLANK.**



# Software Downloading

---

QUANTAR and Quantro stations, ASTRO-TAC comparators, and ASTRO-TAC receivers (equipped with FLASH memory) support the Software Download (SWDL) feature. This feature allows service personnel to download the station operating software (previously stored in firmware) directly to the station. The download may be performed either locally, through a null modem, or remotely, through a dial-up modem. The SWDL process differs from connecting to a device through RSS because SWDL requires the use of file transfer protocol (FTP) and RSS does not. Therefore, you must configure a modem to use serial line internet protocol (SLIP) because SLIP supports FTP. The process for performing a SWDL to upgrade your device's software is outlined below:

1. Ensure the prerequisites are met. See “Prerequisites” on page 11-2.
2. Prepare the PC for connecting to the station, receiver, or comparator. See “Preparing PC for Software Download Communications” on page 11-3.



## NOTE

Step 3 is needed only if your device is an IntelliRepeater and you are going to connect through an Ethernet connection or a zone controller link connection.

3. Copy the device software from the Motorola-supplied disk to the PC hard disk. See “Loading Station Software Files onto the PC” on page 11-41.
4. Connect to the device. See “Connecting to the Device” on page 11-35.
5. Download the station software from the PC to the station:
  - **If your device is not an IntelliRepeater:** See “Downloading Software to Station/ Receiver Memory - Conventional and 6809 Controller Systems or ASTRO-TAC Comparator Memory” on page 11-41.
  - **If your device is an IntelliRepeater:** See “Downloading Software to IntelliRepeater Memory” on page 11-45.

## Prerequisites

---

Only QUANTAR and Quantro stations, ASTRO-TAC comparators, and ASTRO-TAC receivers that are equipped with FLASH memory allow software downloading. Verify that the Motorola model numbers for the station control board, wireline interface board, and wireline/power supply board are as follows. The model number is printed on an adhesive label on the component side of the board, along with a bar code as follows:

- QUANTAR/Quantro Stations:
  - Station control board:
    - **IntelliRepeater:** CLN6960
    - **Conventional/6809:** CLN6961
    - **Data base station:** CLN6962
  - Wireline interface board:
    - **4-wire North America:** CLN6955
    - **8-wire North America:** CLN6956
    - **4-wire International:** CLN6957
    - **8-wire International:** CLN6958
- ASTRO-TAC Receivers:
  - **Wireline/power supply board:** TTN5041
  - **Station control board:** CLN6873
- ASTRO-TAC Comparator:
  - **Flash Capable Comparator Control Board:** CLN7361
  - **Flash Capable Wireline Board:** CLN7343



### NOTE

If your station/receiver is equipped with a model different than those listed above, the station operating software is contained in EPROMs, you may not use the Software Download feature unless the module has been upgraded with FLASH memory. Refer to *FLASHport Upgrades Ordering Guide* for details.

## Preparing PC for Software Download Communications

The software download (SWDL) feature can be installed and run on the following Microsoft Windows operating systems:

- Windows XP Professional
- Windows Vista
- Windows 7

Configure your PC for connecting to the device depending on the Microsoft Windows operating system you are running and the method of serial communications you are using as outlined below:

- If connecting the PC's serial port directly to the station's RSS port:
  - For Windows XP, see "Adding a Null Modem Device in Microsoft Windows XP Professional" on page 11-3.
  - For Windows Vista and Windows 7, see "Adding a Virtual Network Adapter Driver in Microsoft Windows Vista and Windows 7" on page 11-25.
- If connecting through a dial-up modem:
  - For Windows XP, see "Adding a Dial-Up Modem Device in Microsoft Windows XP Professional" on page 11-15.
  - For Windows Vista and Windows 7, see "Adding a Virtual Network Adapter Driver in Microsoft Windows Vista and Windows 7" on page 11-25.

## Adding a Null Modem Device in Microsoft Windows XP Professional

To connect to the station or comparator to perform Software Download using a direct connection, you must:

1. Add a null modem that uses your computer's serial port. This is used to connect to the device. See "Adding a Null Modem in Windows XP Professional" on page 11-3.
2. Add a SLIP connection that uses the null modem you just added. See "Adding a SLIP Connection in Windows XP Professional for a Null Modem Connection" on page 11-8.

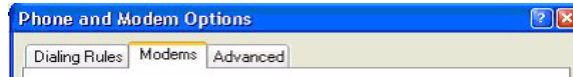
### Adding a Null Modem in Windows XP Professional

To add a null modem to connect to the device, perform the following procedure:

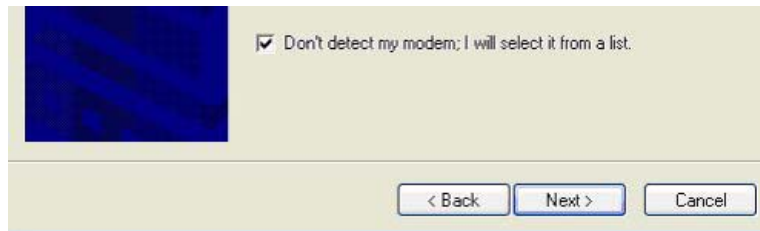
1. Open the **Control Panel**.
2. Click **Printers and Other Hardware**.
3. Click **Phone and Modem Options**.



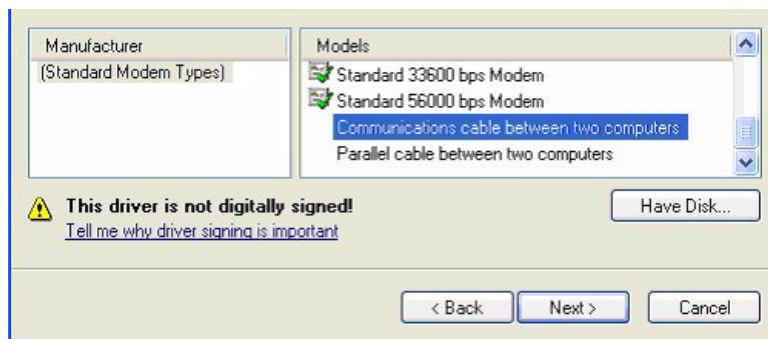
4. On the window that appears, click the **Modems** tab.



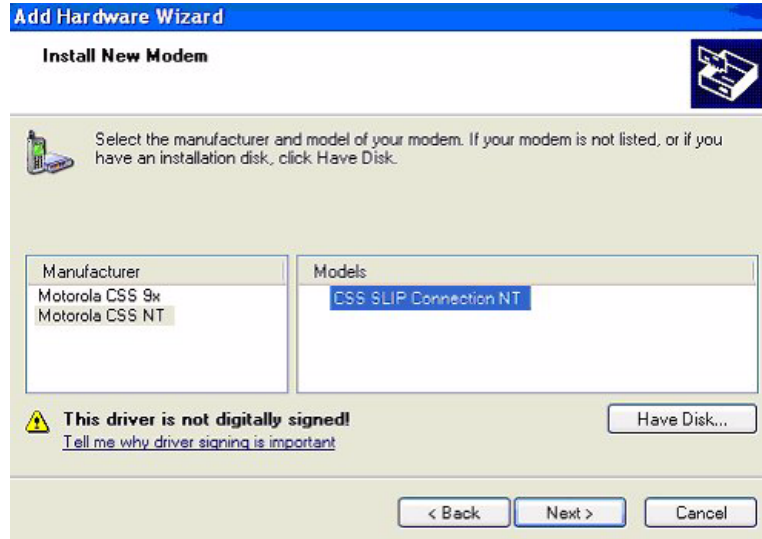
5. Click **Add** at the bottom of the screen. The following window appears.



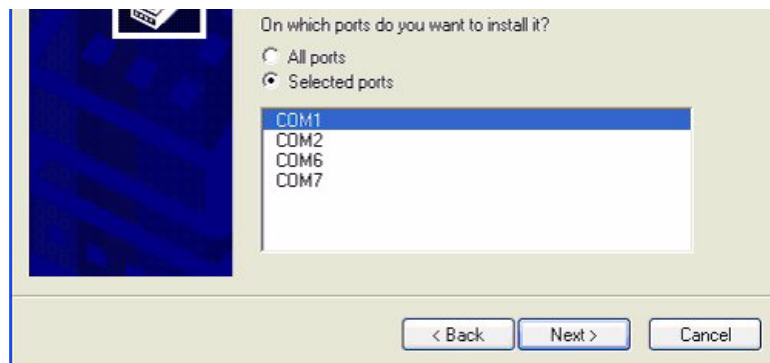
6. Select **Don't detect my modem; I will select it from a list** check box.
7. Click **Next**. The following window appears.



8. Click **Have Disk**.
9. On the screen that appears, browse to the directory that contains the **mdmmotcss9x.inf** and **mdmmotcssnt.inf** files. Generally, these files are found in the default installation directory C:\Program Files\Motorola\Radio Service Software\SLIPdrv\XP.
10. Click **Open**. The following window appears.



11. Select the following:
  - **Motorola CSS NT** from the Manufacturers list.
  - **CSS SLIP Connection NT** from the Models list.
12. Click **Next**. The following window appears.



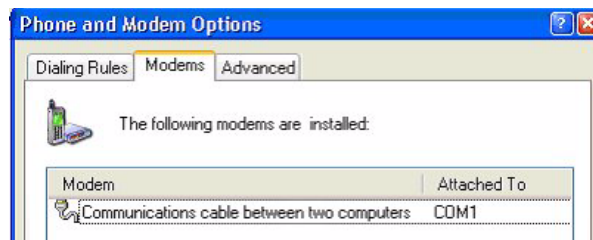
13. Select the following:
  - Click **Selected ports**.
  - Select the PC port that you use to perform the serial software download to the device.
14. Click **Next**. The following warning message appears.



15. Click **Continue Anyway** to disregard it. If the operation was successful, the following window appears.



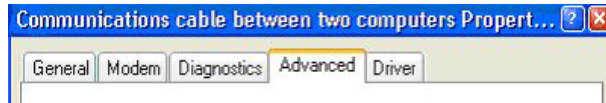
16. Click **Finish** to exit. The following window appears. This window now contains the modem connection you just added.



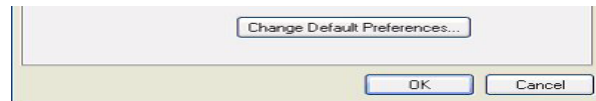
17. Select your new connection.

18. Click **Properties** at the bottom.

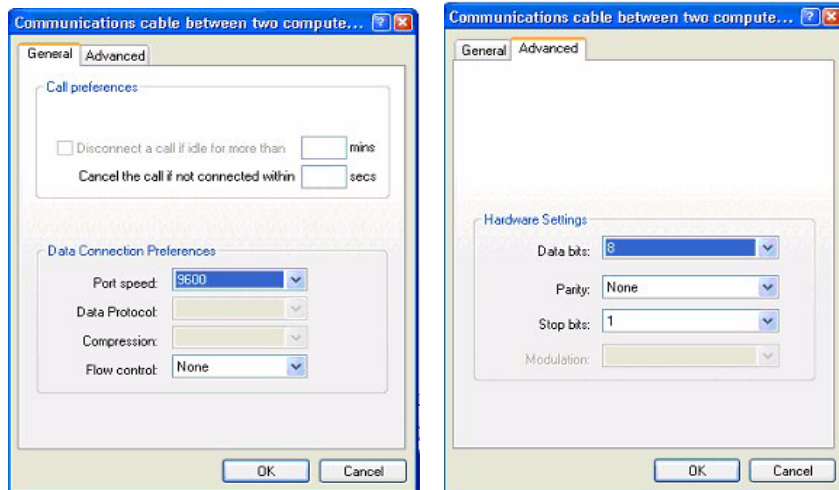
19. Select the **Advanced** tab.



20. Click **Change Default Preferences...** at the bottom of the screen.



The following window appears.



21. Select the following on the **General** tab:

- **Flow control:** None
- **Port Speed:** 38400

22. Select the following on the **Advanced** tab:

- **Data bits:** 8
- **Parity:** None
- **Stop bits:** 1

23. Click **OK** on all open screens until you reach the control panel again.

You have successfully added a null modem that provides the means to connect to a station or comparator using a SLIP connection. Proceed with the following section to add a SLIP connection.

## Adding a SLIP Connection in Windows XP Professional for a Null Modem Connection

To add a SLIP connection in Windows XP perform the following procedure:

1. Launch the Control Panel and click on the **Network Connections** icon.



The following menu appears.

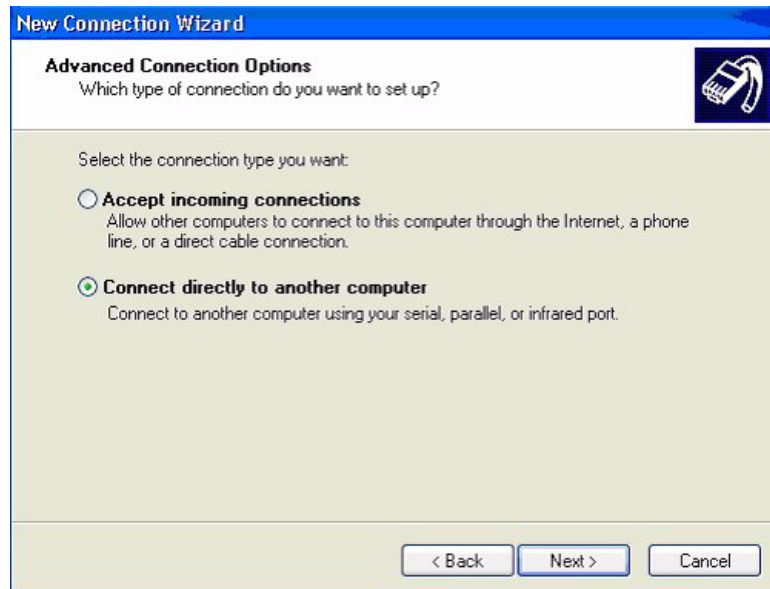


2. Select **New Connection** from the File menu.
3. When the next window appears, click **Next**. The following window appears.





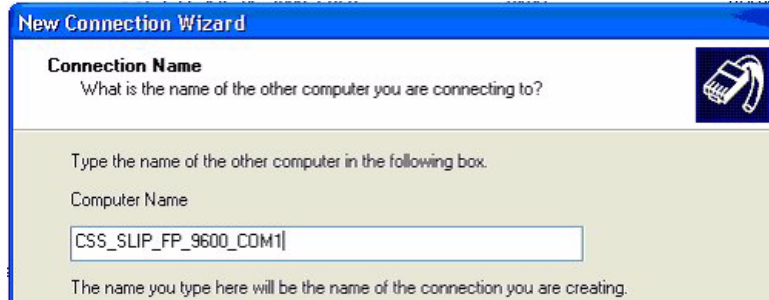
4. Select **Set up an advanced connection**.
5. Click **Next**. The following window appears.



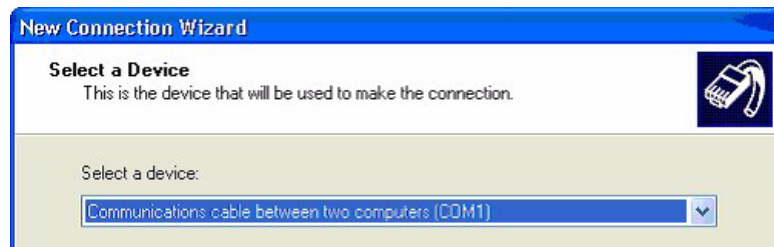
6. Select **Connect directly to another computer**.
7. Click **Next**. The following window appears.



8. Select **Guest**, then click **Next**. The following window appears.



9. Enter the name of the connection in accordance with the rules provided in “RSS SLIP Connection Naming Convention” on page 11-34.
10. Click **Next**. The following window appears.



11. Select the device you just added from the dropdown box.
12. Click **Next**. The following window appears.



13. Select **Anyone’s use**, then click **Next**. The following window appears.



14. Click **Finish**. The following window appears.

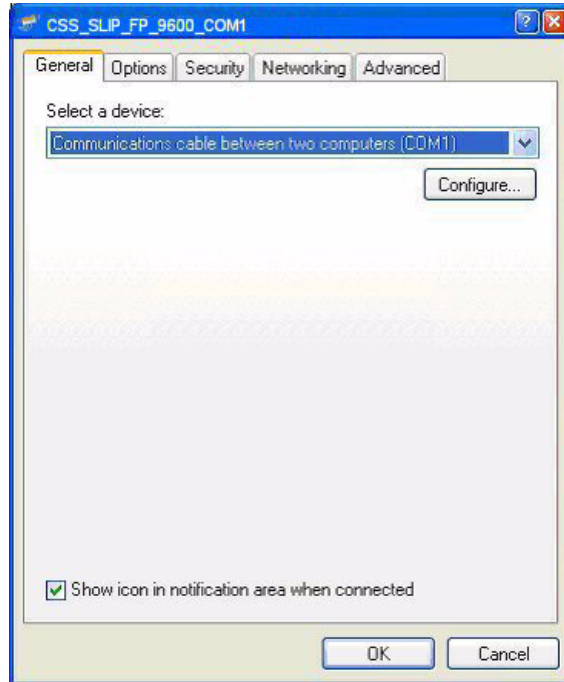


#### NOTE

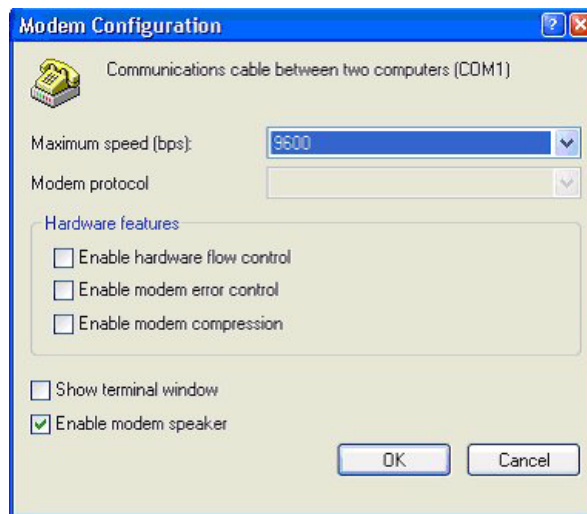
Leave the area code and phone number fields blank.



15. Click **Properties**. The following window appears.



16. Select the device you just added and then click **Configure**. The following window appears.



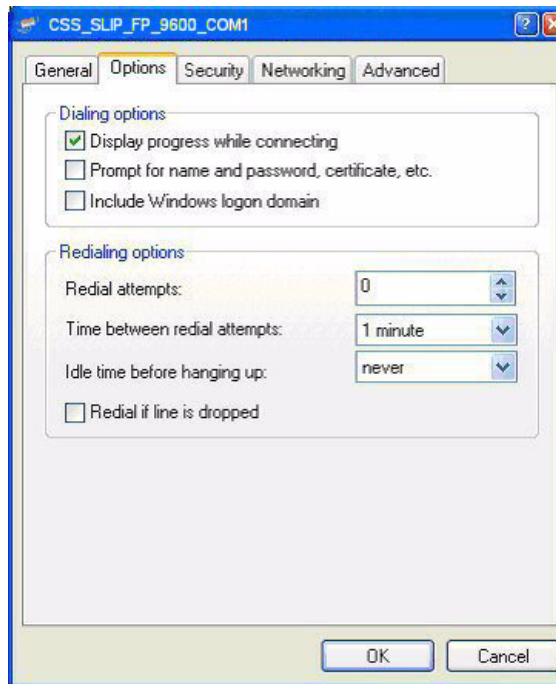
17. Select the desired baud rate and uncheck all other checkboxes. You can only select baud rate values that are supported by RSS.



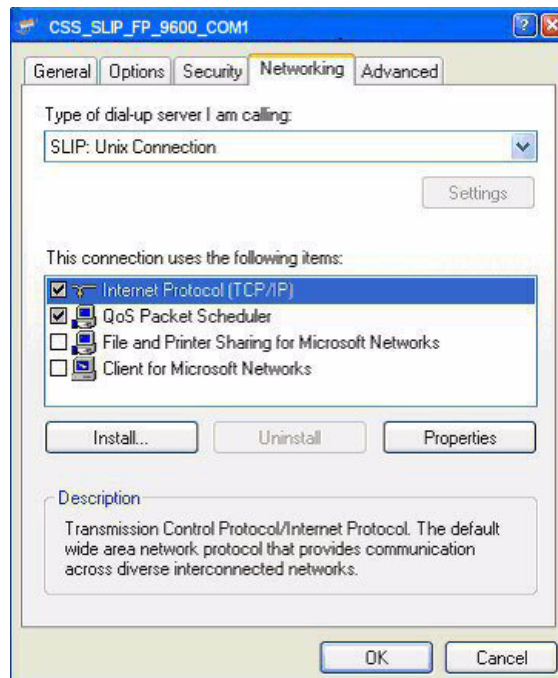
**NOTE**

See “RSS SLIP Connection Naming Convention” on page 11-34 for baud rate and connection name dependencies.

18. Click **OK**. The following window appears. Select the **Options** tab and set the option selection as shown in the figure below.

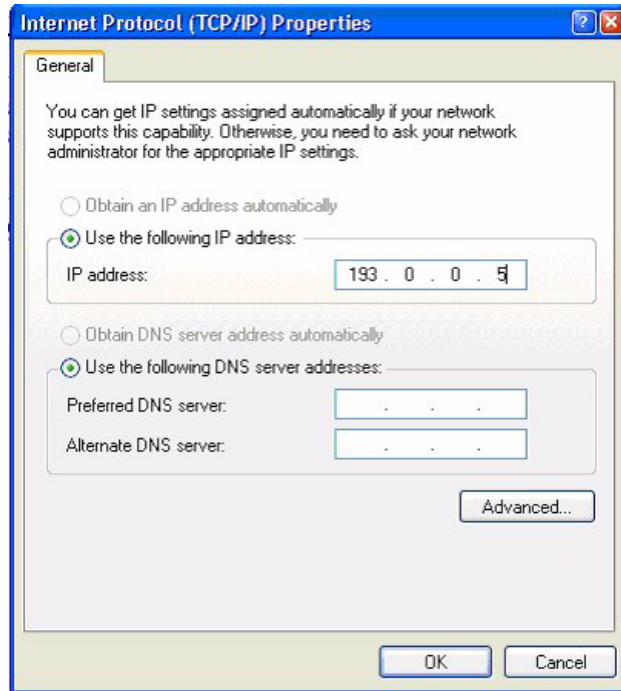


19. Select the **Networking** tab and set the option selection as shown in the figure below.



20. Select **SLIP: Unix Connection** in the **Type of dial-up server I am calling:** list
21. Select the **Internet Protocol (TCP/IP)** entry.

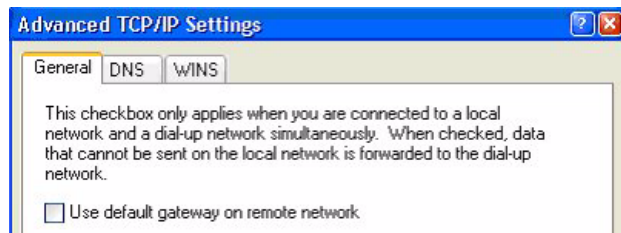
22. Click **Properties**. The following window appears.



23. Set the **IP Address** field as follows, leaving the rest blank:

- If the connection being configured connects to the front port of the device, the IP should be 193.0.0.5
- If the connection being configured connects to the back port of the device, the IP should be 193.0.0.4

24. Click **Advanced**. The following window appears.



25. Uncheck the **Use default gateway on remote network** check box.

26. Click **OK** on all windows until you reach the **Network Connections** screen. When you finish clicking **OK** on all windows, a **Connect** window appears, offering you the opportunity to connect to the device. Click **Cancel** to close the **Connect** window.



**NOTE**

You cannot connect to the device using the **Connect** window, a successful connection can only be made using the RSS.

You are now ready to perform the SWDL procedure to upgrade the device's software. See "Serial (Direct) Connection" on page 11-35.

## Adding a Dial-Up Modem Device in Microsoft Windows XP Professional

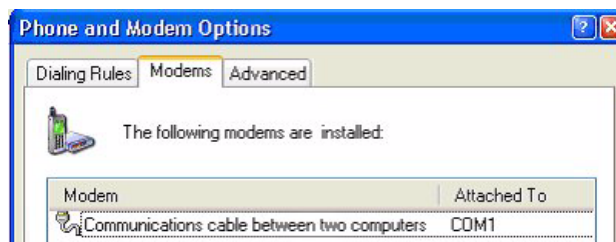
To connect to the station or comparator to perform Software Download using a remote connection, you must:

1. Add a dial-up modem that is used to connect to the device at a remote location. See "Adding a Dial-Up Modem in Windows XP Professional" on page 11-15.
2. Add a SLIP connection that uses the modem you just added. See "Adding a SLIP Connection in Windows XP Professional for a Dial-Up Modem Connection" on page 11-17.

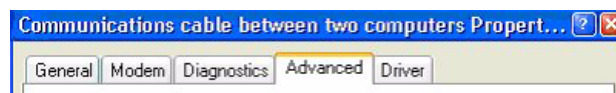
### Adding a Dial-Up Modem in Windows XP Professional

To add a dial-up modem to connect to the device from a remote location, install the dial-up modem in your computer in accordance with the installation instructions provided by the manufacturer. On completion of the new modem's installation or for an existing modem, set up the dial-up modem as directed in the procedure below:

1. If not already open, (it opens by default when adding a new modem) open the **Modem Options** window from **Control Panel**. The following window appears.

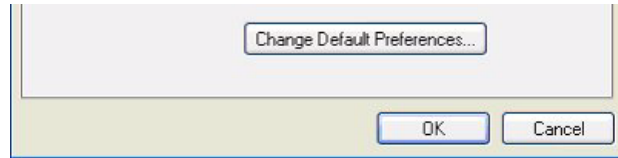


2. Select the modem from the list.
3. Click **Properties** at the bottom.
4. Select the **Advanced** tab.

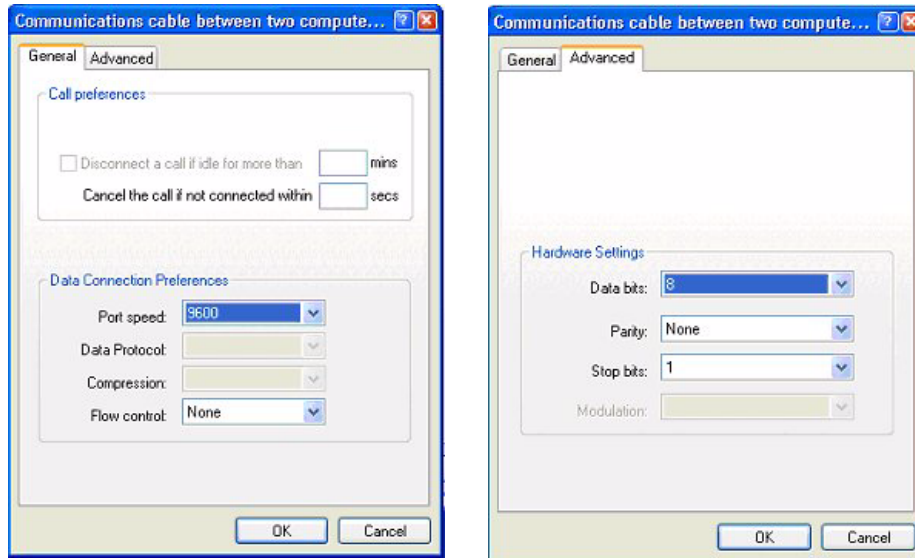


5. Click **Change Default Preferences...** found at the bottom of the screen.





The following window appears.



6. Select the following on the **General** tab:
  - **Flow control:** None
  - **Port Speed:** 38400
7. Select the following on the **Advanced** tab:
  - **Data bits:** 8
  - **Parity:** None
  - **Stop bits:** 1
8. Click **OK** on all open windows until you reach the control panel again.

You have successfully added a dial-up modem that provides the means to connect to a station or comparator using a SLIP connection from a remote location. Proceed with the following section to add a SLIP connection.



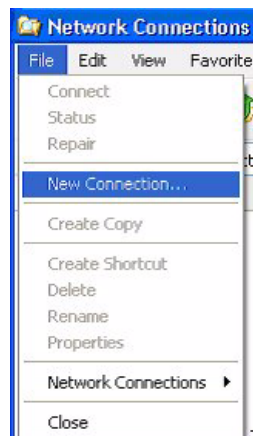
## Adding a SLIP Connection in Windows XP Professional for a Dial-Up Modem Connection

To add a SLIP connection in Windows XP to connect to a device from a remote location, perform the following procedure:

1. Open the Control Panel and double-click the **Network Connections** icon.



2. On the window that appears, from the **File** menu, select **New Connection**.



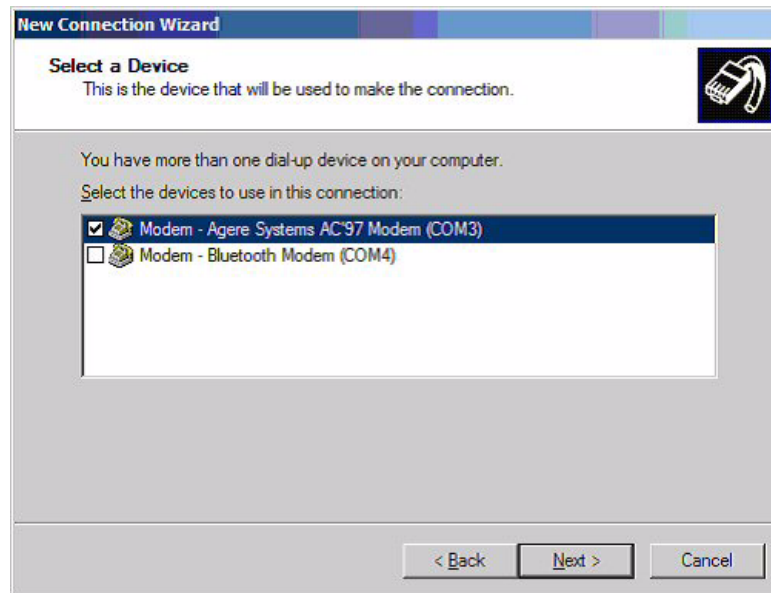
3. Click **Next** on the window that appears.



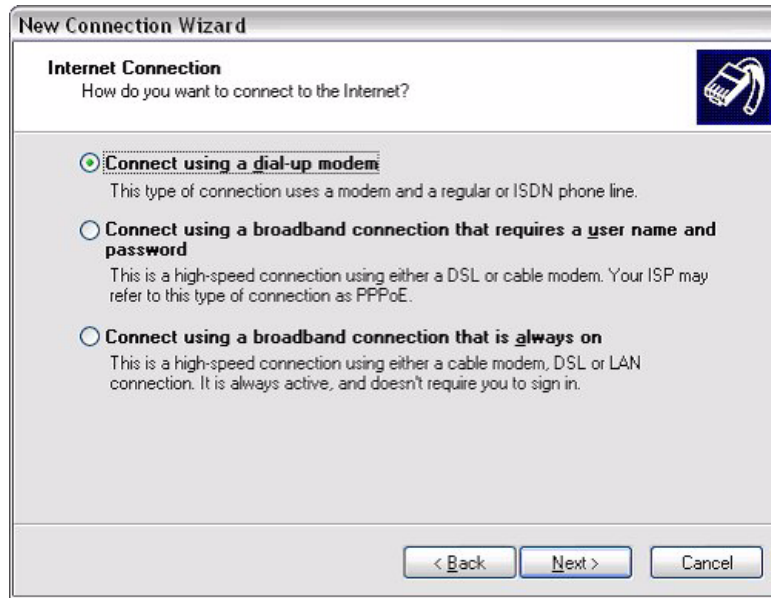
4. Select **Connect to the Internet**.
5. Click **Next**. The following window appears.



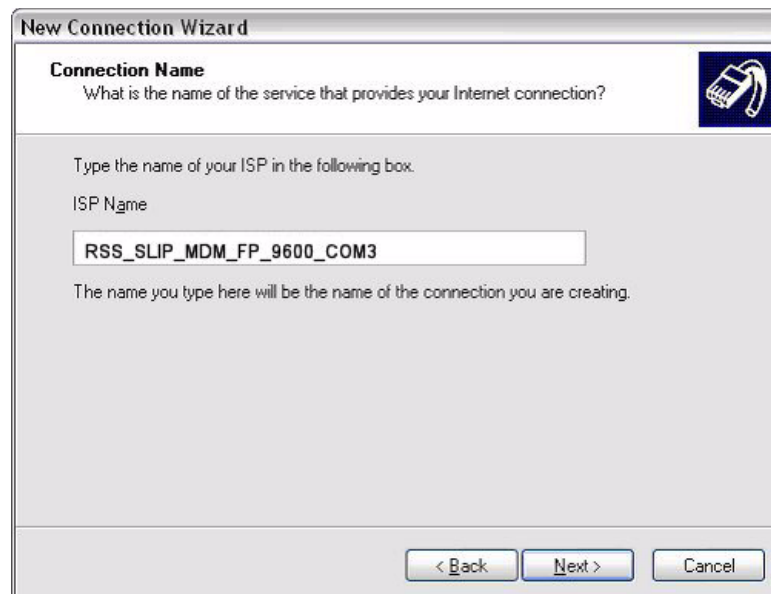
6. Select **Set up my connection manually**.
7. Click **Next**. The **New Connection Wizard** window appears as shown in the example below.



8. Select the modem device that you use for this connection.
9. Click **Next**. The following window appears.



10. Select **Connect Using a dial-up modem**.
11. Click **Next**. The following window appears.



12. Enter the name of the connection in accordance with the rules outlined in “RSS SLIP Connection Naming Convention” on page 11-34. Do not add any other text to the name other than what is stated in the rules.
13. Click **Next**. The following window appears.



14. Leave the phone number field blank and click **Next**. The following window appears.



15. Select **Anyone's use**, then click **Next**. The following window appears.

**New Connection Wizard**

**Internet Account Information**  
You will need an account name and password to sign in to your Internet account.

Type an ISP account name and password, then write down this information and store it in a safe place. (If you have forgotten an existing account name or password, contact your ISP.)

User name:

Password:

Confirm password:

Use this account name and password when anyone connects to the Internet from this computer

Make this the default Internet connection

Turn on Internet Connection Firewall for this connection

< Back   Next >   Cancel

16. Leave all the fields blank and uncheck all checkboxes.
17. Click **Next**. The following window appears.

**New Connection Wizard**

**Completing the New Connection Wizard**

You have successfully completed the steps needed to create the following connection:

**RSS\_SLIP\_MDM\_FP\_9600\_COM3**

- Share with all users of this computer

The connection will be saved in the Network Connections folder.

Add a shortcut to this connection to my desktop

To create the connection and close this wizard, click Finish.

< Back   Finish   Cancel

18. Click **Finish**. The following window appears.



#### NOTE

Leave the area code and phone number fields blank.

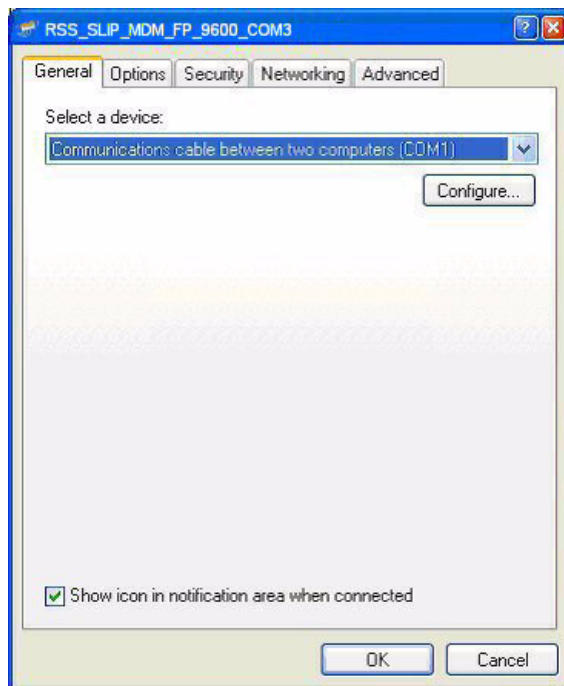


19. Click **Properties**. The following window appears.

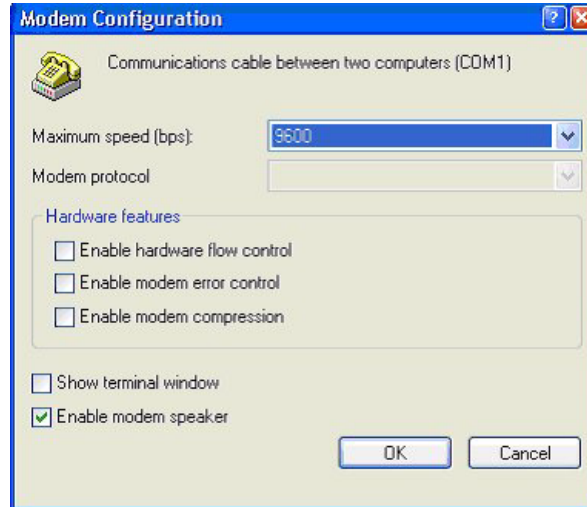


**NOTE**

Leave the area code and phone number fields blank.



20. Select the device you just added and then click **Configure**. The following window appears.



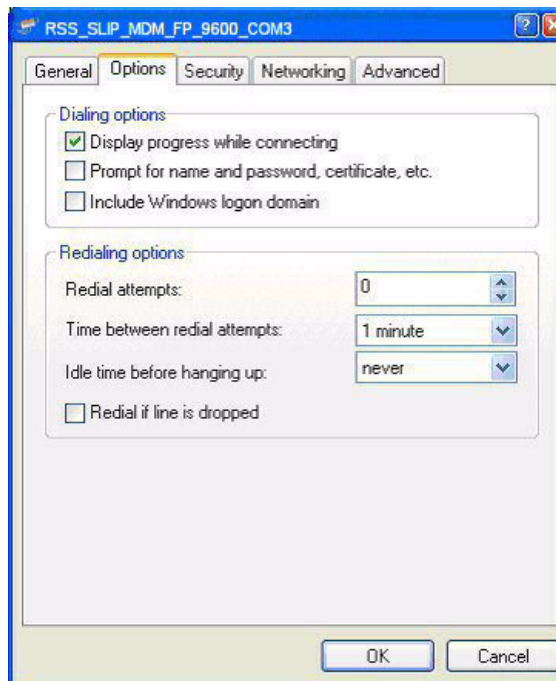
21. Select the desired baud rate and uncheck all other check boxes. You can only select baud rate values that are supported by RSS.



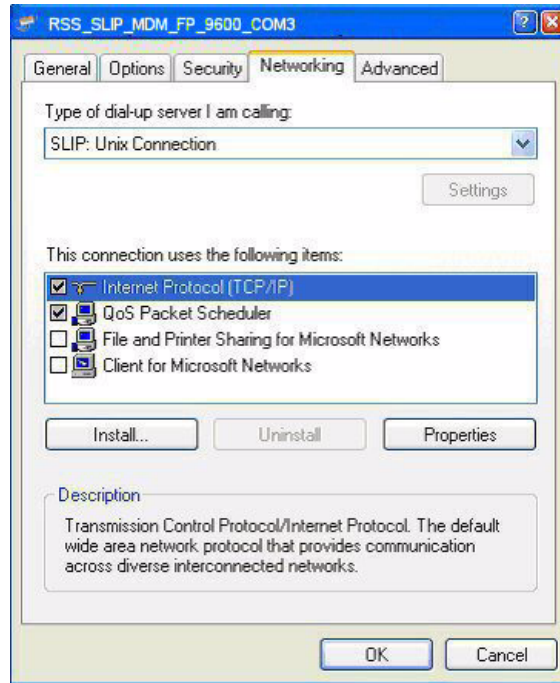
#### NOTE

See “RSS SLIP Connection Naming Convention” on page 11-34 for baud rate and connection name dependencies.

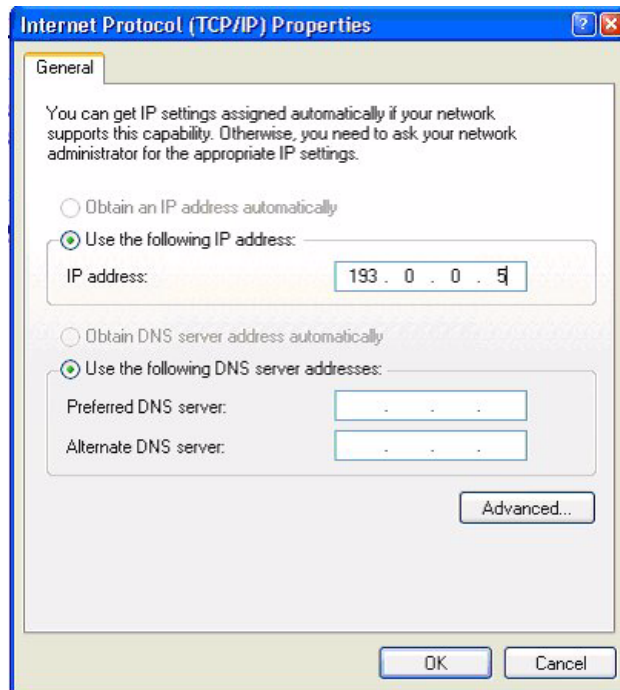
22. Click **OK**.
23. Select the **Options** tab and set the option selection as shown in the figure below.



24. Select the **Networking** tab. The following screen appears.

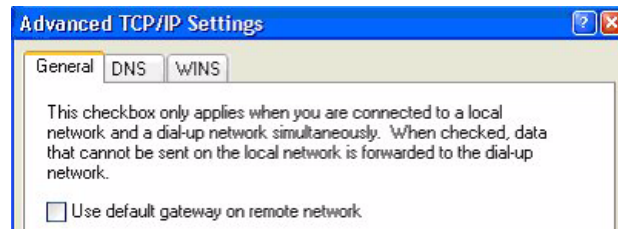


25. Select **SLIP: Unix Connection** in the **Type of dial-up server I am calling:** list.
26. Select the **Internet Protocol (TCP/IP)** entry.
27. Click **Properties**. The following window appears.





28. Set the **IP Address** field as follows, leaving the rest blank:
  - If the connection being configured connects to the front port of the device, the IP should be 193.0.0.5
  - If the connection being configured connects to the back port of the device, the IP should be 193.0.0.4
29. Click **Advanced**. The following window appears.



30. Uncheck the **Use default gateway on remote network** check box.
31. Click **OK** on all windows until you reach the **Network Connections** screen. When you finish clicking **OK** on all windows, a **Connect** window appears offering you the opportunity to connect to the device. Click **Cancel** to close the **Connect** window.



#### NOTE

You cannot connect to the device using the **Connect** window, a successful connection can only be made using the RSS.

You are now ready to perform the SWDL procedure to upgrade the device's software. See "Remote Dial-Up Connections" on page 11-38.

## Adding a Virtual Network Adapter Driver in Microsoft Windows Vista and Windows 7

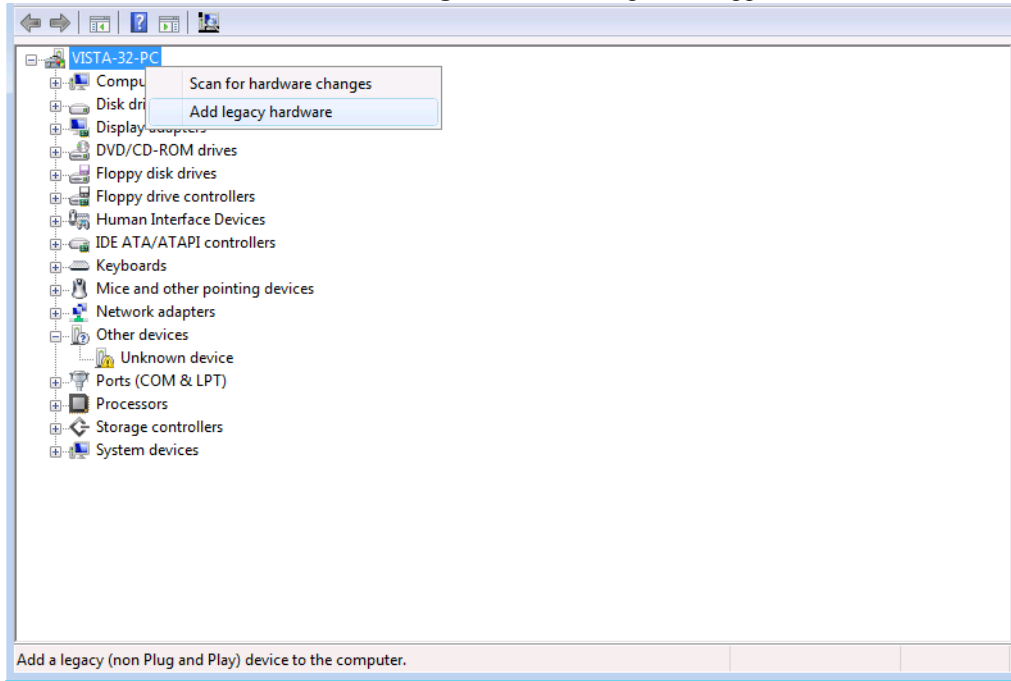
To connect to the station or comparator to perform Software Download using a direct or remote connection, you must add a Virtual Network Adapter that uses your computer's serial port. This is used to connect to the device. See "Adding a Virtual Network Adapter Driver in Microsoft Windows Vista and Windows 7" on page 11-25.

### Adding a Virtual Network Adapter Driver in Windows Vista and Windows 7

To add a Virtual Network Adapter driver to connect to the device, perform the following procedure:

1. Open the **Control Panel**.

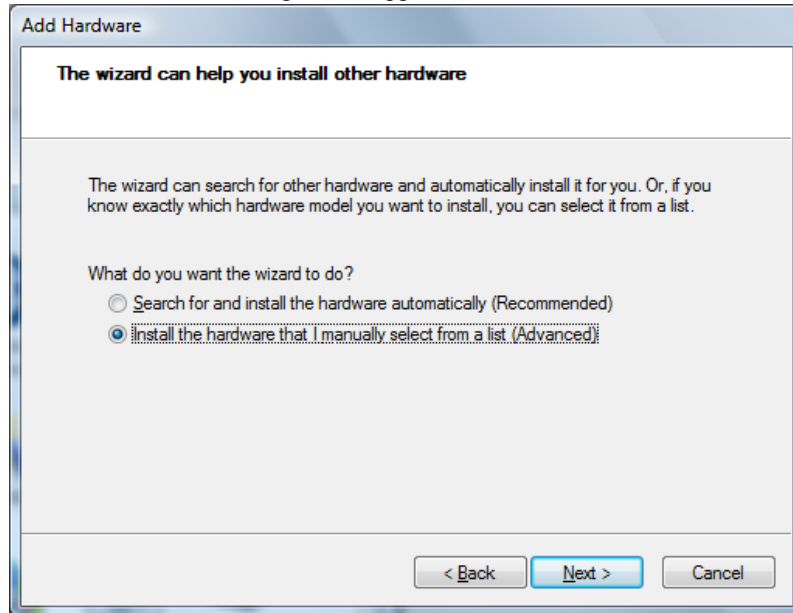
2. Click **Device Manager**. The following screen appears.



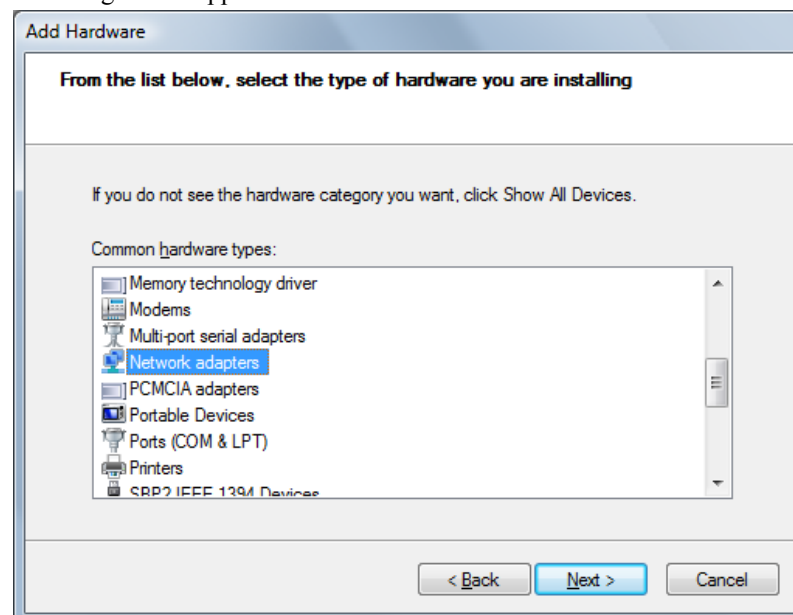
3. Right-click on a computer's name in a root of the tree and select **Add legacy hardware**. The following screen appears.



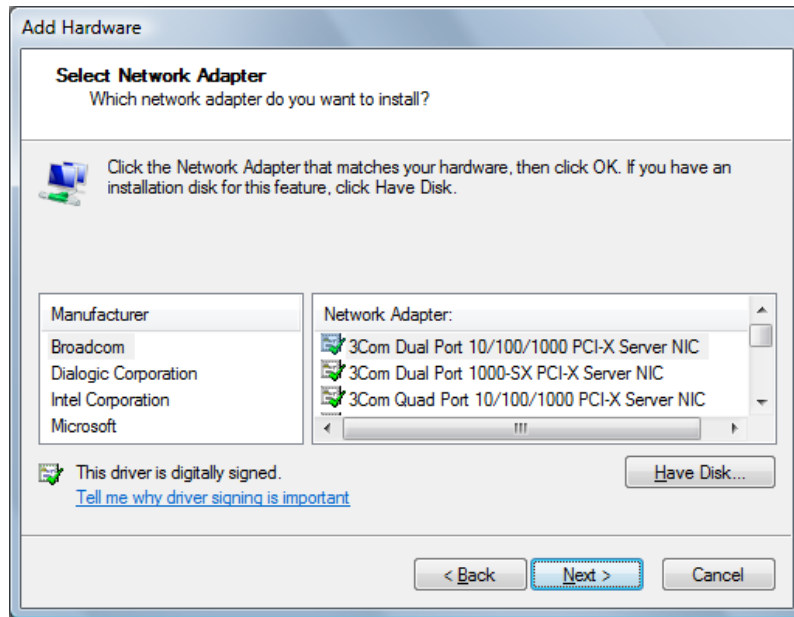
4. Click **Next**. The following screen appears.



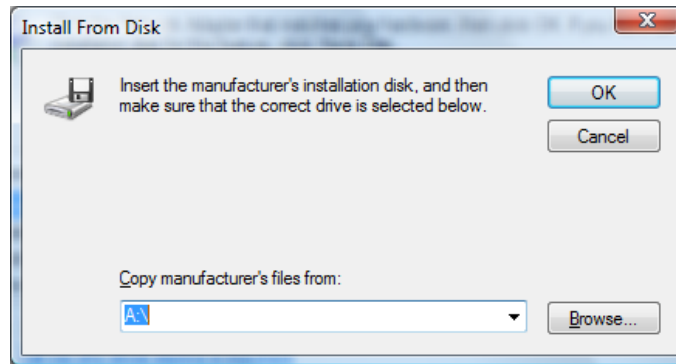
5. Select **Install the hardware that I manually select from a list** and click **Next**. The following screen appears.



6. Select **Network adapters** and click **Next**. The following screen appears.



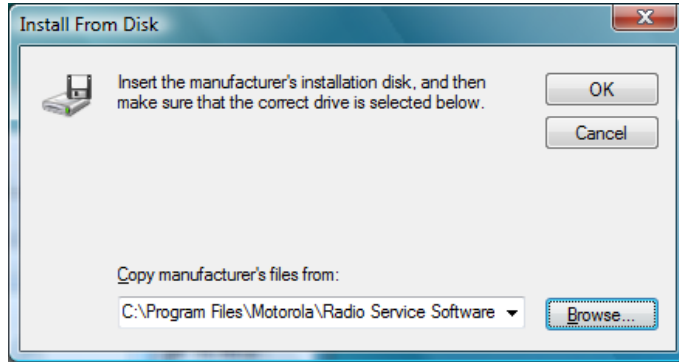
7. Click **Have Disk**. The Install From Disk screen appears.



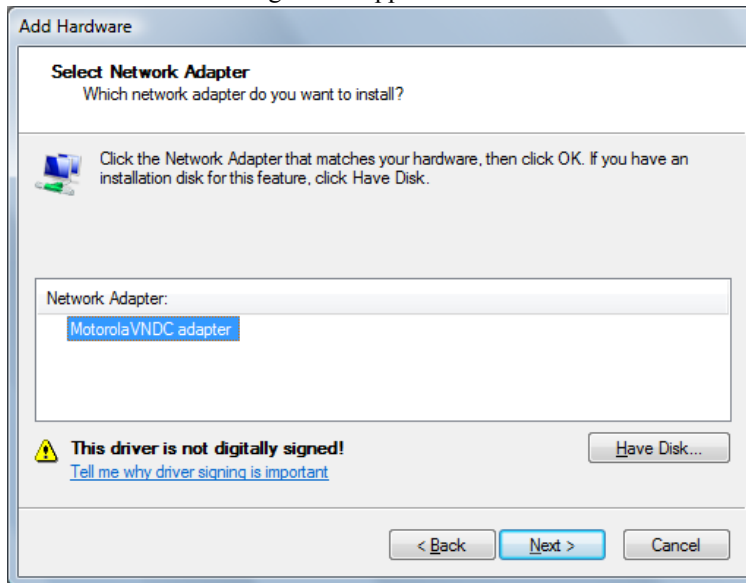
8. Click **Browse** and navigate to the directory that contains the **MotorolaVNDC.inf** file. Generally, this file is found in the default installation directory:

- For Windows Vista:  
C:\Program Files\Motorola\Radio Service Software\SLIPdrv\Vista.
- For Windows 7 32 bits:  
C:\Program Files\Motorola\Radio Service Software\SLIPdrv\Win7.
- For Windows 7 64 bits:  
C:\Program Files (x86)\Motorola\Radio Service Software\SLIPdrv\Win7.

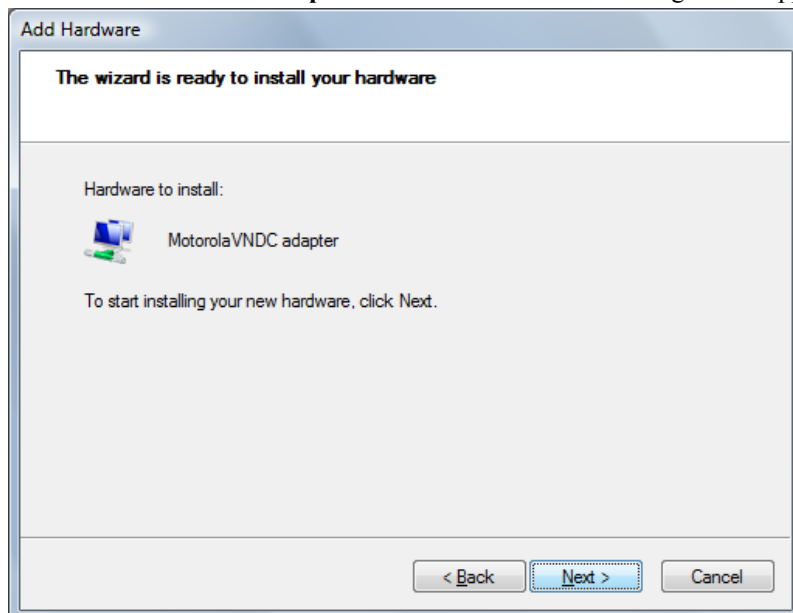
Select the MotorolaVNDC file and click **Open**. The Install From Disk window becomes active again.



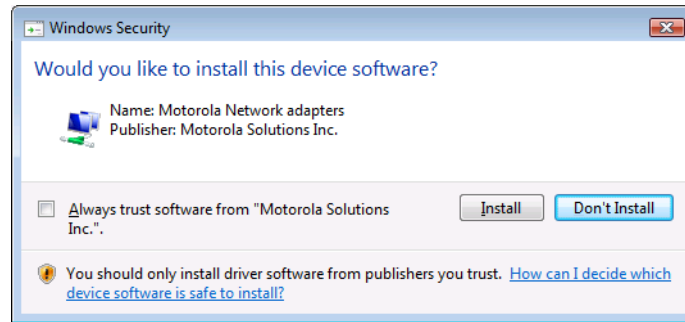
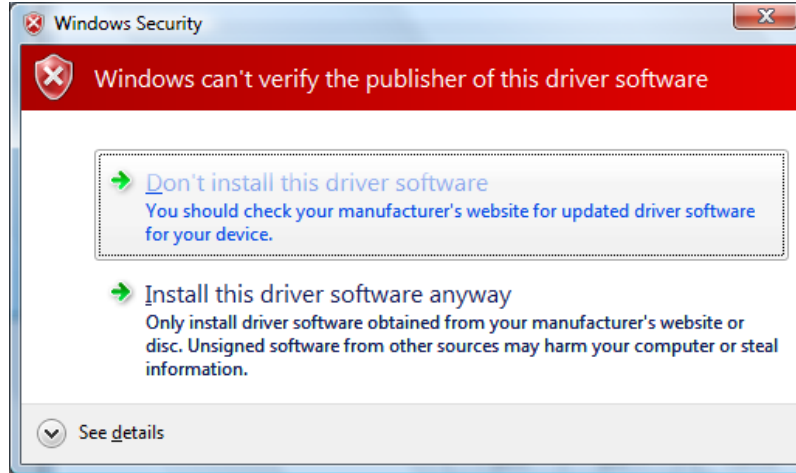
9. Click **OK**. The following screen appears.



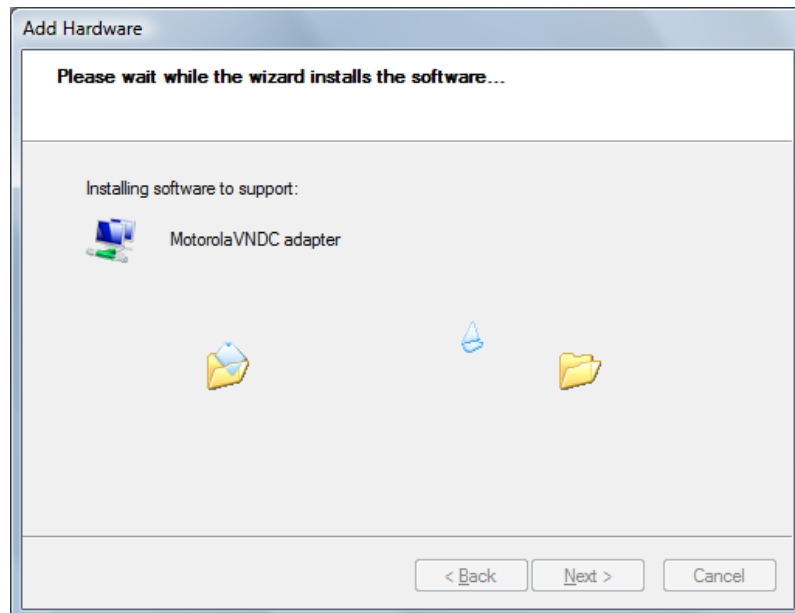
10. Select **MotorolaVNDC adapter** and click **Next**. The following screen appears.



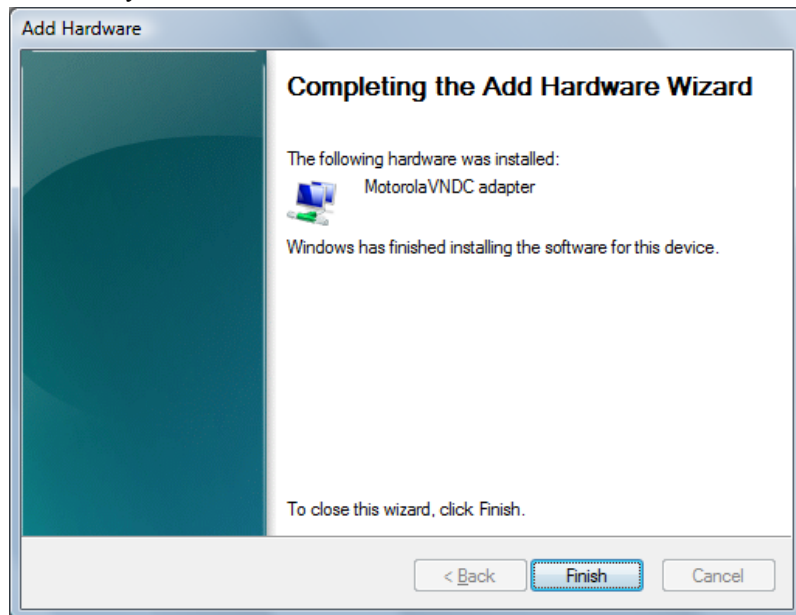
11. Click **Next**. One of the following screens appears.



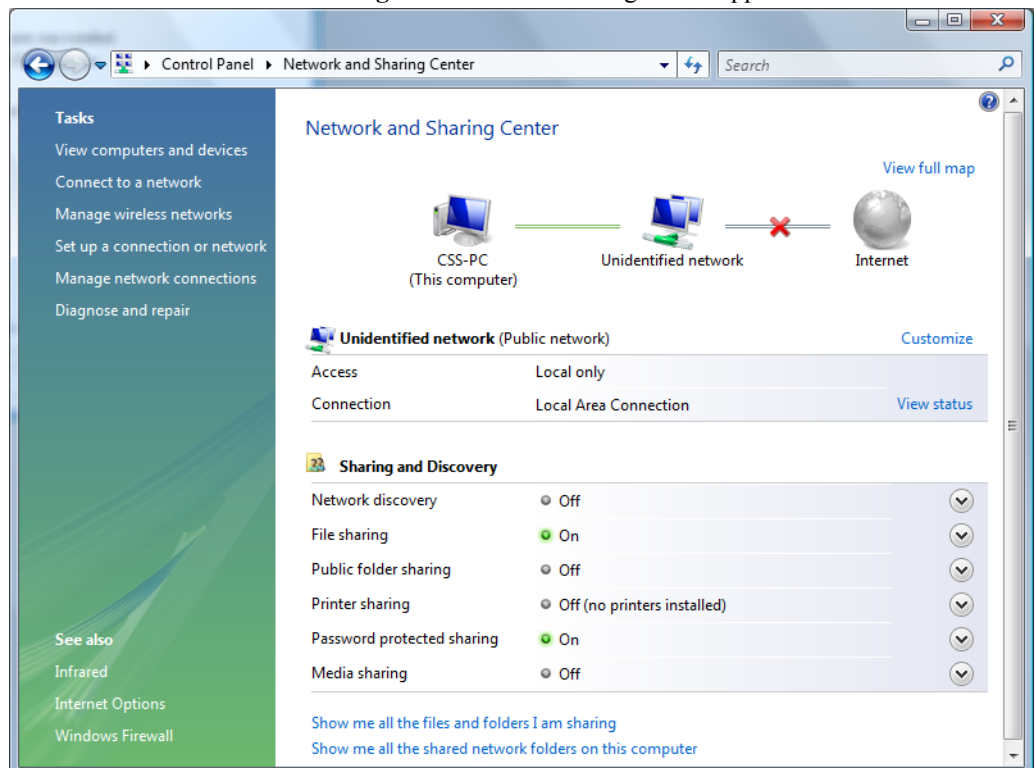
12. Click **Install**. During the driver installation the following screen appears.



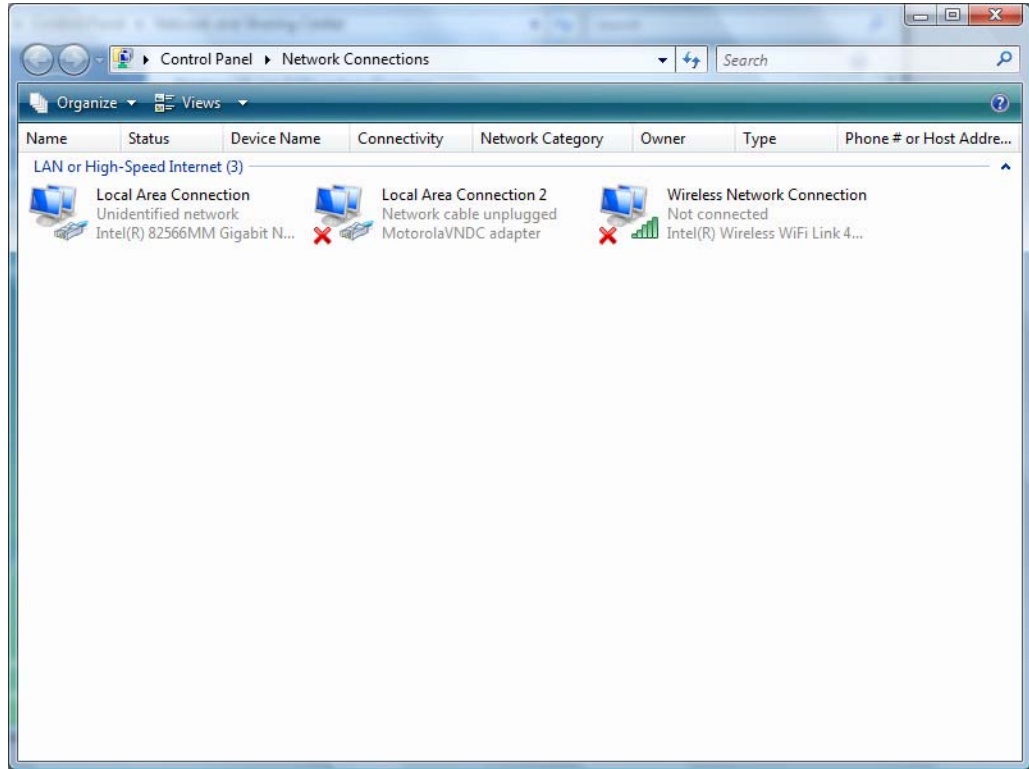
13. The following completion window appears when the driver software has been successfully installed.



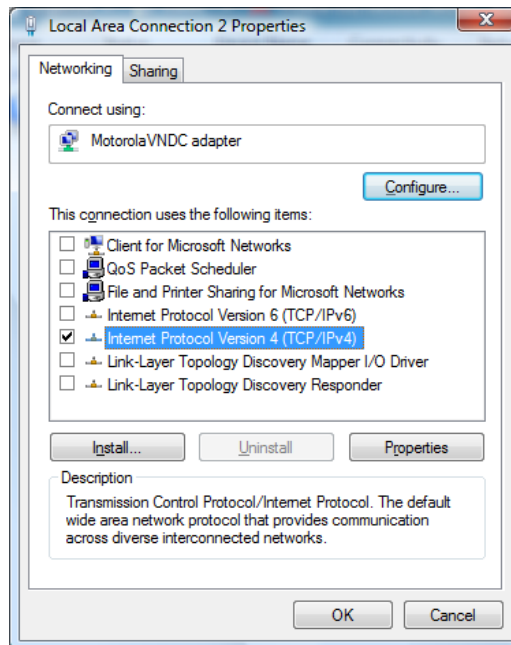
14. Click **Finish**.
15. Open the **Control Panel**.
16. Click **Network and Sharing Center**. The following screen appears.



17. Click **Manage network connections**. The following screen appears.

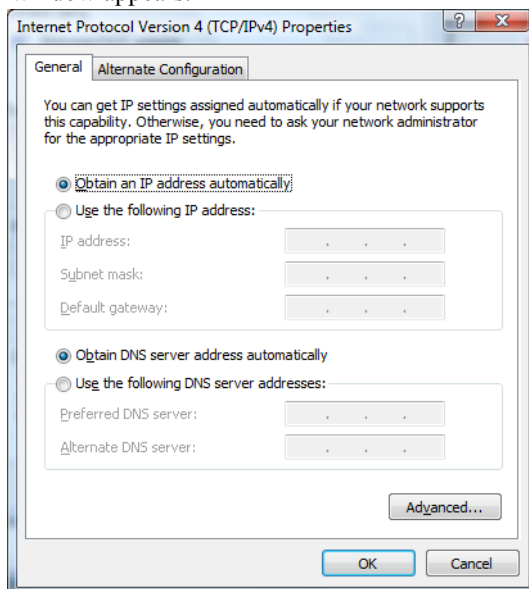


18. Right-click the icon for the network with the the MotorolaVNDc adapter, and then click **Properties**. The Network Connection Properties window appears.





19. Select **Internet Protocol Version 4** and deselect all other connections, then highlight **Internet Protocol Version 4** and click **Properties**. The Internet Protocol Properties window appears.



20. Select **Obtain an IP address automatically** and **Obtain DNS server address automatically**, then click **OK**. The Network Connection Properties window returns.
21. Click **OK**. You are now ready to perform the SWDL procedure to upgrade the device's software.
- For direct connections, see “Serial (Direct) Connection” on page 11-35.
  - For remote connections, see “Remote Dial-Up Connections” on page 11-38.

## RSS SLIP Connection Naming Convention

Due to the limitation of dynamic creation of a SLIP connection using the Windows Remote Access Service (RAS) module, a naming convention was created to allow the RSS to communicate with the Windows RAS through a null modem (serial cable).



### NOTE

The CSS application uses the same connections for null modem (serial) SWDL, therefore the same naming is used for both applications.

## Naming Convention for Null Modem install

A Windows RSS SLIP connection name has three items that depend on and describe some physical parameters of the connection. A typical RSS SLIP connection name is `CSS_SLIP_FP_9600_COM1`, and breaks down as follows:

- **CSS\_SLIP**: This part of the connection name is fixed. All RSS SLIP connections must start with this string.
- **FP**: This part of the name describes the device port the connection is capable of connecting with. Allowed strings are “FP” (front port) and “BP” (back port).
- **9600**: This part of the name describes the baud rate at which the connection communicates. This value must match the actual baud rate of the connection.
- **COM1**: This part of the name describes the PC communications port that is used to establish the connection.



### WARNING

**RSS SLIP connections must be created in pairs. For a given baud rate/PC communications port combination, create one connection for the device front port and one for the back port.**

**Example:** If the SLIP connection `CSS_SLIP_FP_9600_COM1` is created, then the following must also be created: `CSS_SLIP_BP_9600_COM1`. This meets the requirement that a name be created for both the front and back port on the device.

## Naming Convention for Dial-Up Modem install

A Windows RSS SLIP connection name has three items which depend and describe some physical parameters of the connection. A typical RSS SLIP connection name is `RSS_SLIP_MDM_FP_9600_COM1`, and breaks down as follows:

- **RSS\_SLIP\_MDM**: This part of the connection name is fixed. All RSS SLIP dial-up modem connections must start with this string.
- **FP**: This part of the name describes the device port the connection is capable of connecting with. Possible values are “FP” (front port) and “BP” (back port).
- **9600**: This part of the name describes the connection’s baud rate. This value must match the actual baud rate of the connection.
- **COM1**: This part of the name describes the PC communications port that is used to establish the connection.



### WARNING

**RSS SLIP connections must be created in pairs. For a given baud rate/PC communications port combination, create one connection for the device front port and one for the back port.**

**Example:** If the name `CSS_SLIP_FP_9600_COM1` is created, then the following must also be created: `CSS_SLIP_BP_9600_COM1`. This meets the requirement that a name be created for both the front and back port on the device.

## Connecting to the Device

---

There are four methods for connecting the PC to the station for downloading software. Use the one appropriate for the installation as outlined below:

- Serial connection between the PC and a single station (or one of the stations in an IntelliRepeater Ethernet network). See “Serial (Direct) Connection” on page 11-35.
- Ethernet connection between PC and a single station (or to the access point in an IntelliRepeater Ethernet network). See “Ethernet Connections” on page 11-36.
- Remote connection to a single station (or one of the stations in an IntelliRepeater Ethernet network) using PC and dial-up modem. See “Remote Dial-Up Connections” on page 11-38.
- Zone controller link connection using PC and channel banks/modems (IntelliRepeater systems only). See “Zone Controller Link Connection” on page 11-38.

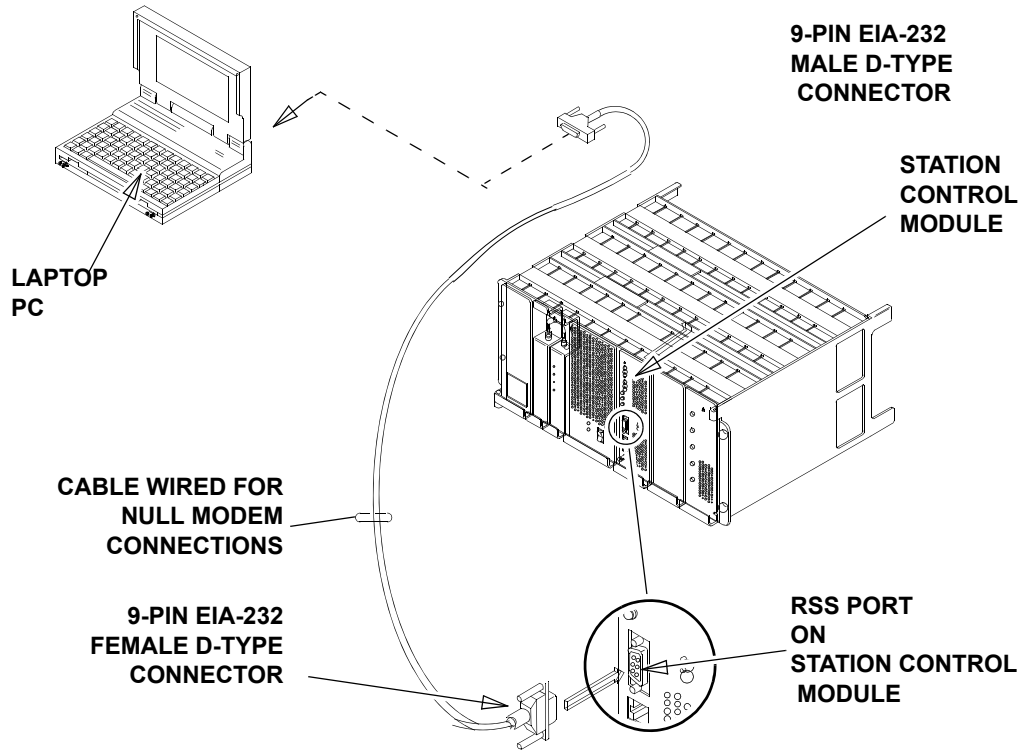
### Serial (Direct) Connection

A serial connection may be made between the PC and the RSS port located on the station control module front panel. You may make the connection to either a single station, or to one of the stations in an IntelliRepeater network.



#### NOTE

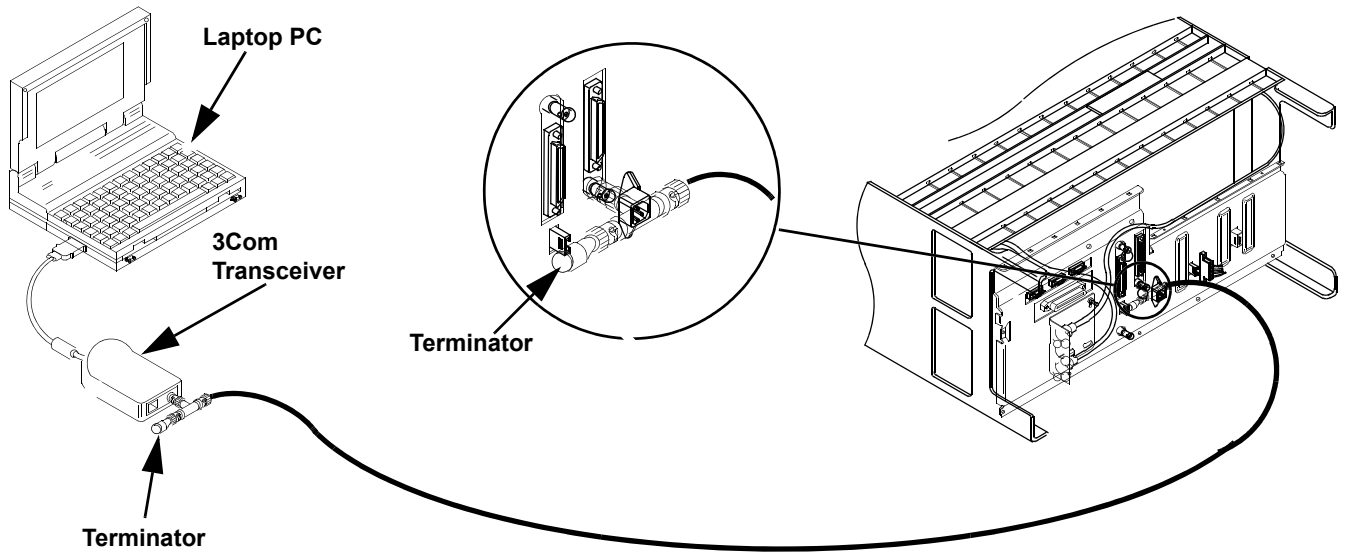
ASTRO-TAC receivers can be downloaded only through the serial port.



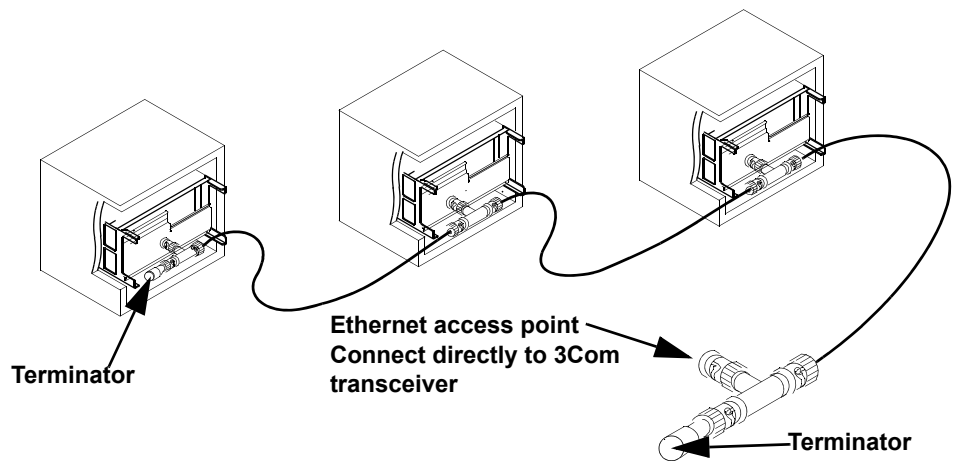
**Figure 11-1** Serial Connection for Software Download

## Ethernet Connections

An Ethernet connection may be made between the PC and either a single station or to the access point of an IntelliRepeater Ethernet network.



**Figure 11-2** Ethernet Connection to a Single Station



**Figure 11-3** Ethernet Connection to IntelliRepeater Ethernet Network

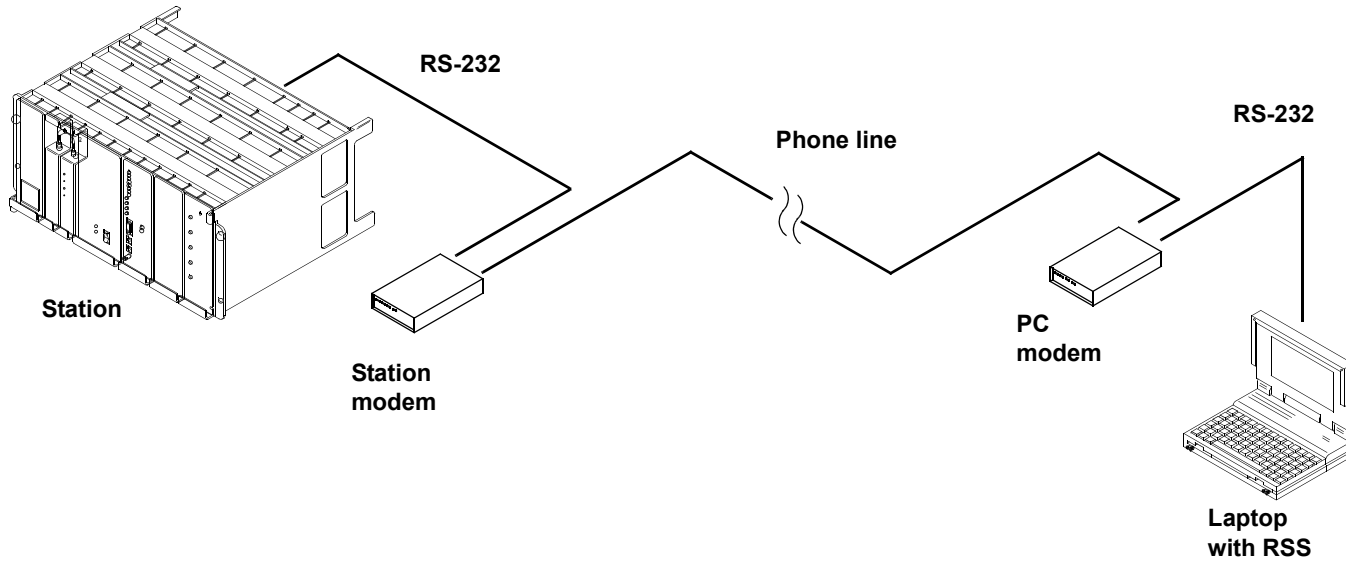


**IMPORTANT**

For IntelliRepeater networks, ensure that each IntelliRepeater station is programmed with a unique IP address. IP addresses are set using RSS. If two IntelliRepeater stations have the same IP address, the network does not work properly. Also, disconnecting any of the IntelliRepeaters' Ethernet cables on a functioning system causes the stations to reset.

## Remote Dial-Up Connections

Using the RSS remote dial-up feature (see Chapter 9, “Remote Dial-Up”), you may establish a modem connection to a remote station and download the software through telephone lines. This type of connection results in download times comparable to serial connection download times.



**Figure 11-4** Remote Dial-Up Connection

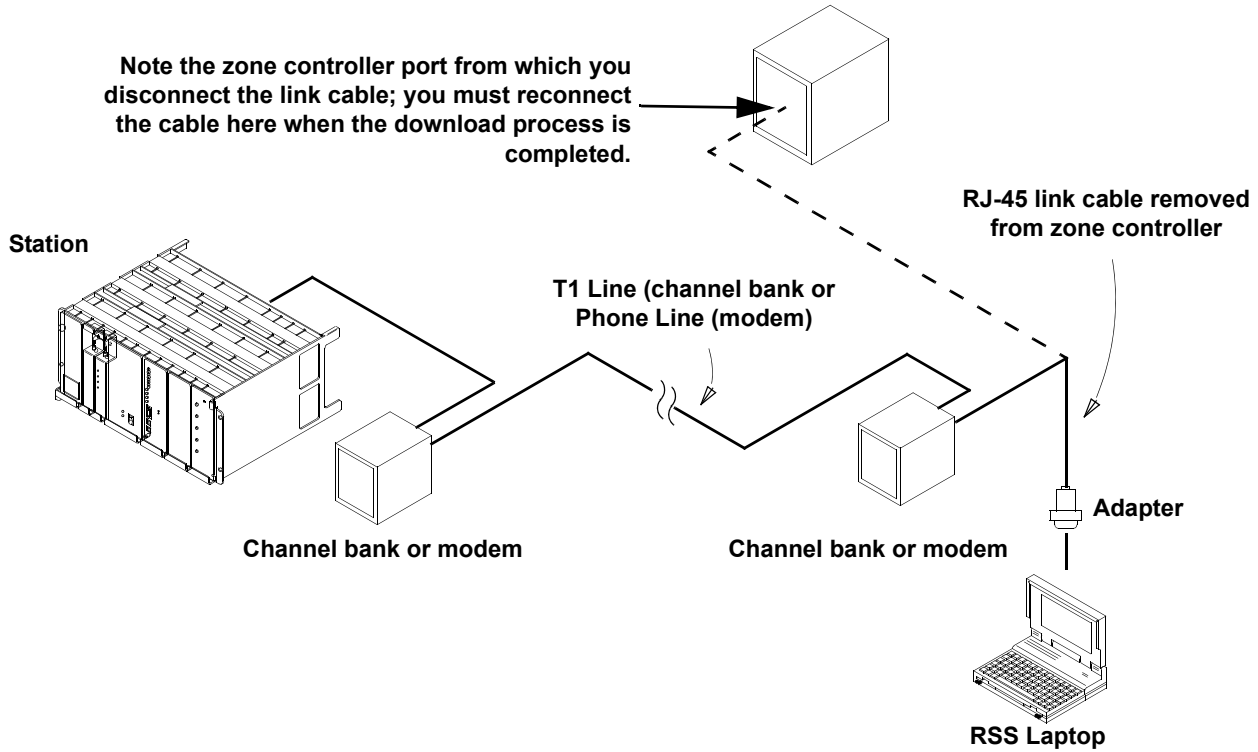
## Zone Controller Link Connection

For SmartZone IntelliRepeater systems (system releases 3.0 and 3.5), you may download the software to a remote station using the zone controller link. This link consists of a cable connected between the zone controller and a local channel bank (typically connected to a remote channel bank through a T1 line) or a local modem. Note that this type of connection results in download times similar to a serial connection, about 10 minutes. The site remains in site trunking for the duration of the download, or a maximum of 30 minutes.

The procedure for software download using the zone controller link depends on the parity required by the system’s zone controller and whether channel banks or modems can be remotely configured. Use the table below to determine your particular scenario and follow the corresponding procedures to perform the software download.

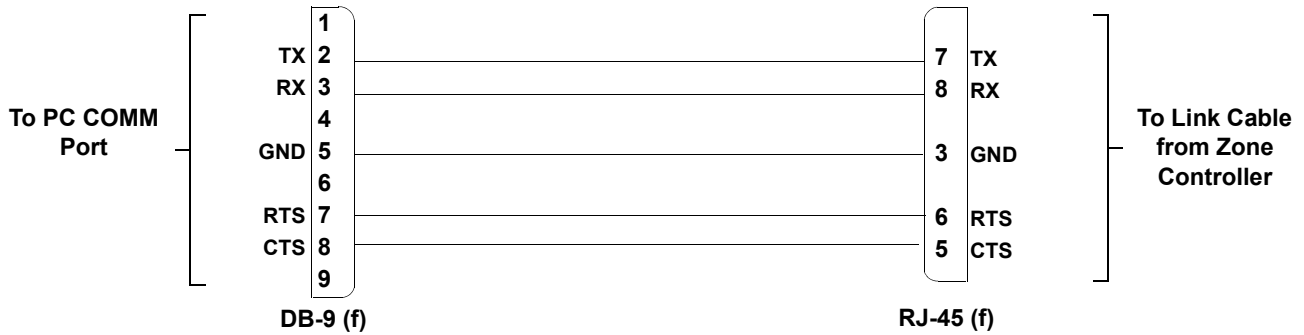
**Table 11-1** Zone Controller Link Connection Scenarios

<b>Zone Controller Parity Requirements</b>	<b>Channel Bank (or Modem) Remotely Configurable</b>	<b>Channel Bank (or Modem) Manually Configurable Only</b>
<p>Zone Controller links that require ODD parity</p>	<p>Issue remote command to Channel Bank (or Modem) to temporarily set parity to NONE.</p> <p>Connect equipment as shown in “Zone Controller Link Connection” on page 11-38.</p> <p>Perform download procedure provided in “Downloading Software to IntelliRepeater Memory” on page 11-45).</p> <p>Issue remote command to channel bank (modem) to return parity setting to ODD.</p> <p>Disconnect the zone controller link cable from the PC and reconnect it to the zone controller port (from which it was removed).</p>	<p>This scenario is not practical because a visit to the IntelliRepeater site is required to set parity to NONE for the download and then return the setting to ODD for normal operation. Instead, take PC to the site and perform the software download locally.</p>
<p>Zone Controller links that can operate with NO parity</p>	<p>Connect equipment as shown in Figure 11-5.</p> <p>Perform download procedure (described in “Downloading Software to IntelliRepeater Memory” on page 11-45).</p> <p>Disconnect the Zone Controller link cable from the PC and reconnect it to the Zone Controller port from which it was removed.</p>	<p>Connect equipment.</p> <p>Perform download procedure (described in “Downloading Software to IntelliRepeater Memory” on page 11-45).</p> <p>Disconnect the Zone Controller link cable from the PC and reconnect it to the Zone Controller port from which it was removed.</p>



**Figure 11-5** Zone Controller Link Connection

For some SmartZone IntelliRepeater systems, a DB-9 (female) to RJ-45 (female) adapter is required to connect between the SLIP-equipped PC and the zone controller link that connects to the site to be downloaded, as shown above. The adapter is available at most electronic stores, and should be wired as shown in Figure 11-6.



**Figure 11-6** Adapter for Connecting between PC and Zone Controller Link



## Loading Station Software Files onto the PC

---

The station operating software is provided on a diskette from Motorola (usually associated with a FLASHport Upgrade option). The files contained on the diskette include the operating software, boot code (optional), and other files required to support the download process. These files must be loaded onto the PC hard disk, as described below.



### NOTE

About 3 MB of free space is required on the PC hard drive to accommodate the station/receiver software files.

1. Insert the Station Software disk into the appropriate disk drive. If auto-launch is enabled, then the installation utility launches and window appears.
2. Click **OK** or **Next**. An instruction screen appears that prompts for the location to install the software files. The default location is:

`c:\MRSS\Quantar\<release_name>`

It is recommended to accept the default. However, if another location is preferred, change to that directory.

3. Click **OK**. The installation process provides an indication of the progress.

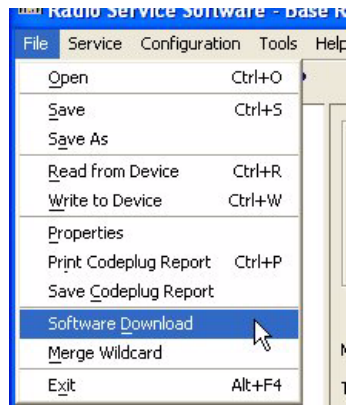
## Downloading Software to Station/Receiver Memory - Conventional and 6809 Controller Systems or ASTRO-TAC Comparator Memory

---

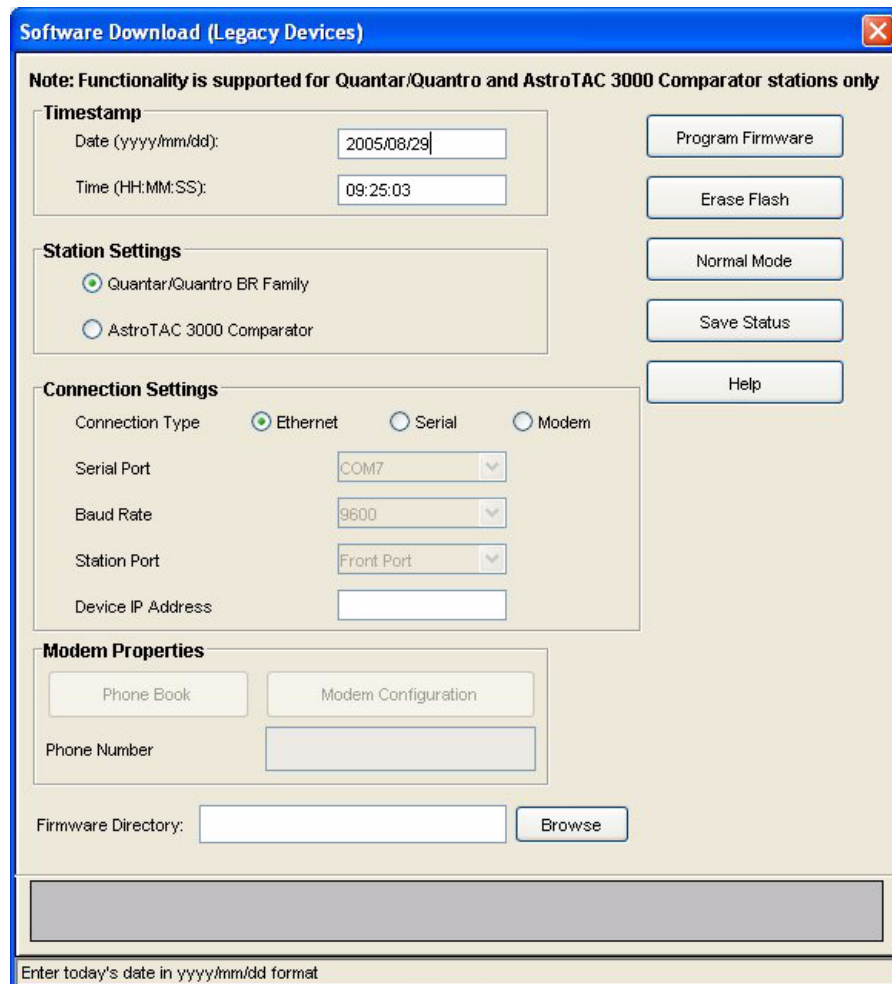
Conventional and 6809 controller based systems and ASTRO-TAC comparator stations require that the new software be downloaded to each device individually. This procedure must be performed for each device in the system. With the device operating software files copied to the PC hard disk, you are now ready to download the software to the device non-volatile memory (firmware).

1. Launch the RSS program as outlined in “Launching the RSS Program” on page 2-12.
2. Connect to the device.
3. Read the current configuration from the device.
4. Verify the currently installed software version by clicking **Versions**, under **Service**, in the navigation pane.

- From the **File** menu, select **Software Download**.

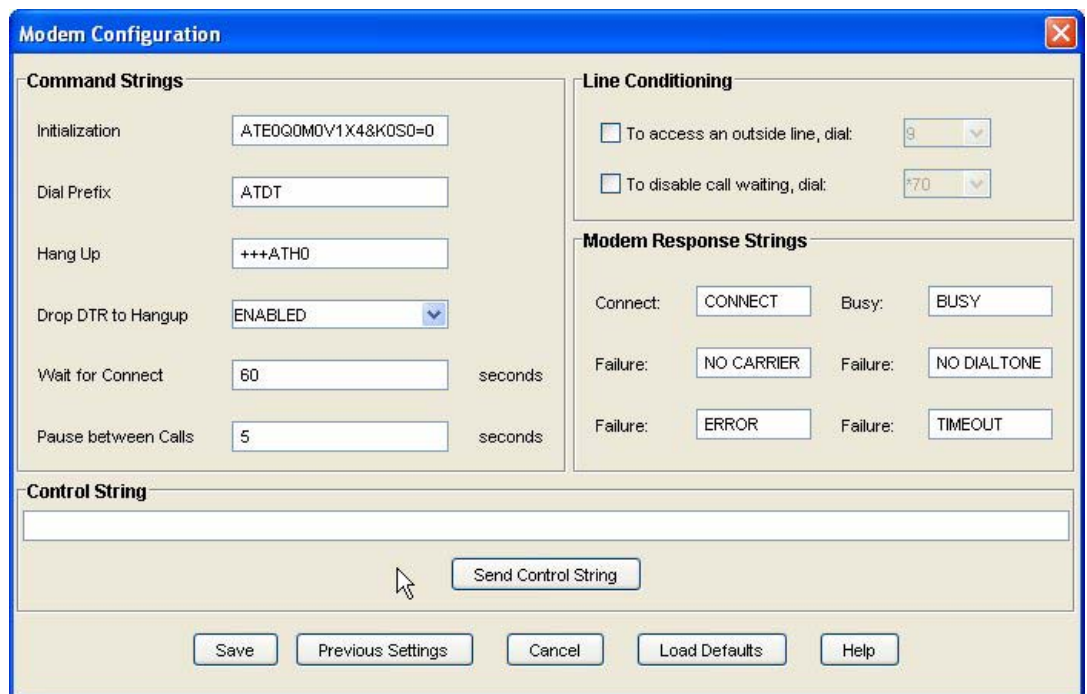


The following window appears.

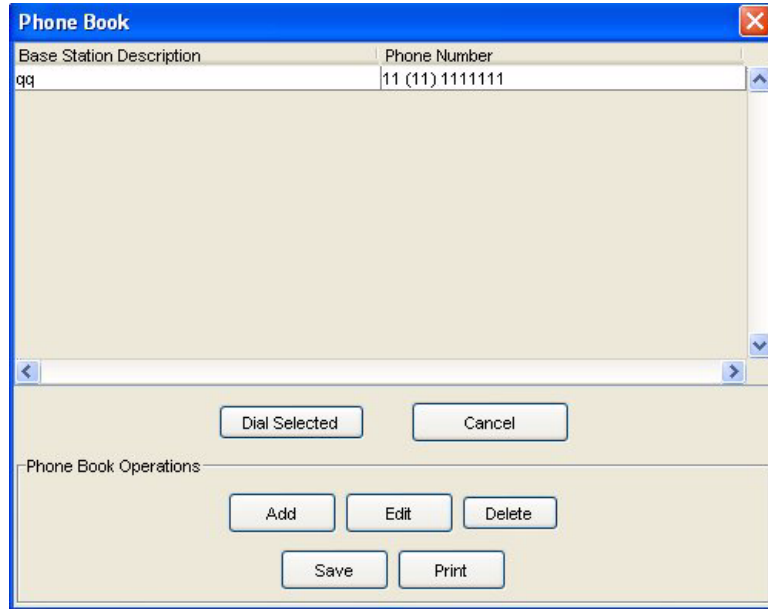


- Set the date and time in the **Timestamp** fields.
- Select the appropriate station type in the **Station Settings** field.

8. Select the appropriate connection type in the Connection Settings area. This determines the fields that are available.
  - **For Ethernet connections:** Enter the station's IP address.
  - **For serial connections:** Configure the following as required for your PC:
    - Serial Port
    - Baud Rate
    - Station Port
  - **For modem connection:** Configure the following as required for your PC and system:
    - Serial Port
    - Baud Rate
    - Station Port
    - Click **Modem Configuration** to configure the modem. The following window appears.



- If required, dial into the station by either:
  - Entering the phone number in the **Phone Number** field or
  - Click **Phone book** and selecting a preconfigured phone number. The following window appears



9. Click **Browse** to locate the upgrade software and then navigating to the file's location on your hard drive.
10. Click **Program Firmware** to start the software download process. The RSS program attempts to establish communications with the station.



#### NOTE

If problems are encountered, an error message appears.

11. After communications have been established, the RSS and the station control module's front panel LEDs indicate the software download progress.
  - **In the RSS:** Progress appears at the bottom of the **Software Download** window.
  - **On the station control module:**
    - All LEDs slowly flash, indicating that the station is in download mode.
    - The LEDs flash sequentially up and down (marquee style) as the station downloads the data from DRAM memory to FLASH memory on the station control module.
    - The station resets when the DRAM to FLASH download is complete.
    - If the station also has new wireline software then following reset, the station control module downloads the wireline operating software to the wireline interface module. This is indicated by the two flashing LEDs on the wireline interface module. Otherwise the station completes its boot process and the station control module's Station On LED lights.
12. A success message appears on successful software download.



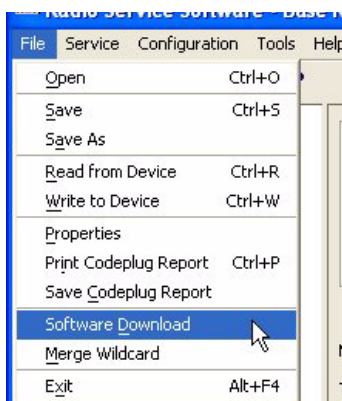
### IMPORTANT

If the station enters a frozen or locked state, the software modules have not been FLASHed properly. To recover, click **Erase Flash**, then repeat the download procedure. Click **Erase Flash** only if you have the software on hand to download to the station. Erasing FLASH renders the station inoperable until software is downloaded.

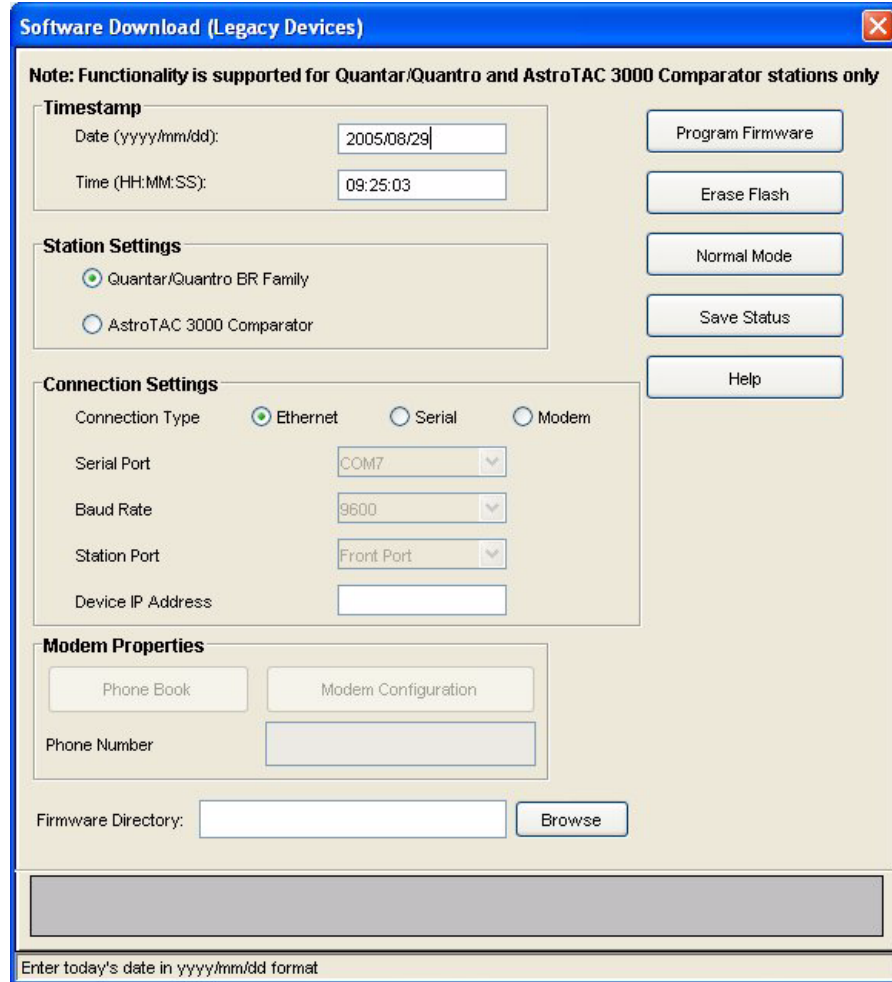
## Downloading Software to IntelliRepeater Memory

IntelliRepeaters allow software to be downloaded to one IntelliRepeater and then that IntelliRepeater loads the software to all other connected IntelliRepeaters. This is called cross loading. With the station operating software files copied to the PC hard disk, you are now ready to download the software to the station non-volatile memory (firmware).

1. Launch the RSS program as outlined in “Launching the RSS Program” on page 2-12.
2. Connect to the device.
3. Read the current configuration from the device.
4. Verify the currently installed software version by clicking **Versions**, under the Service branch, in the navigation pane.
5. From the **File** menu, select **Software Download**.

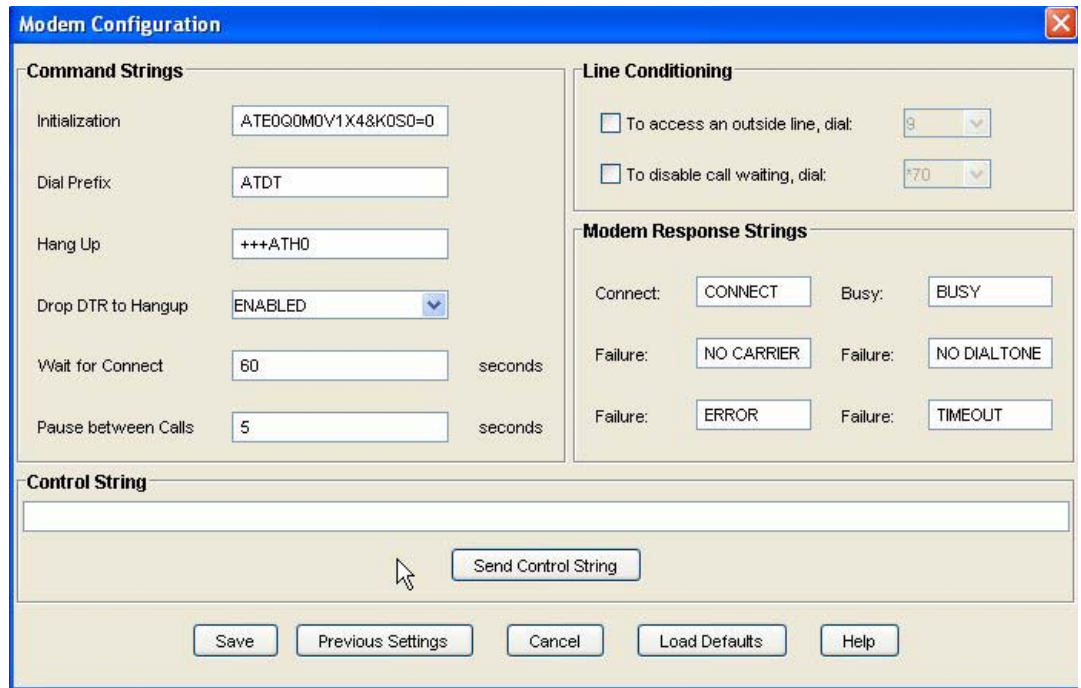


The following window appears.

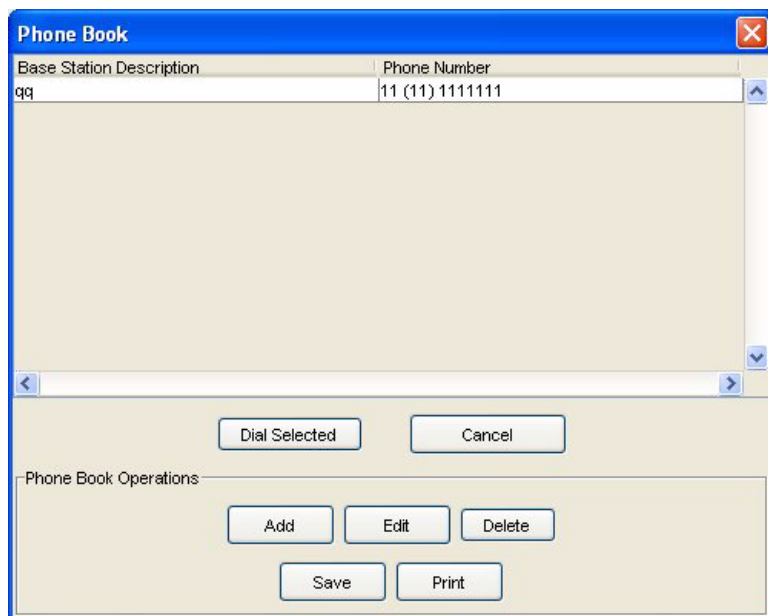


6. Set the date and time in the Timestamp fields.
7. Select the appropriate station type in the **Station Settings** field.
8. Select the appropriate connection type in the Connection Settings area. This determines the fields available.
  - **For Ethernet connections** download: Enter the station’s IP address.
  - **For serial connections:** Configure the following as required for your PC:
    - Serial Port
    - Baud Rate
    - Station Port
  - **For modem connection:** Configure the following as required for your PC and IntelliRepeater system:
    - Serial Port
    - Baud Rate
    - Station Port

- Click **Modem Configuration** to configure the modem. The following window appears.



- If required dial into the IntelliRepeater by either:
  - Entering the phone number in the Phone Number field or
  - Click **Phone book** and select a preconfigured phone number. The following window appears.



9. Click **Browse** to locate the upgrade software and then navigating to the file's location on your hard drive.
10. Click **Program Firmware** to start the software download process. The RSS program attempts to establish communications with the station.

**NOTE**

If problems are encountered, an error message appears.

11. After communications have been established, the RSS and the LEDs on the station control module front panel indicate the software download progress.
  - **In the RSS:** Progress appears at the bottom of the **Software Download** window.
  - **On the station control module:**
    - All LEDs slowly flash, indicating that the station is in download mode.
    - The LEDs flash sequentially up and down (marquee style) as the station downloads the data from DRAM memory to FLASH memory on the station control module.
    - The station resets when DRAM to FLASH download is complete.
    - If the station also has new wireline software, then reset station control module downloads the wireline operating software to the wireline interface module. This is indicated by the two flashing LEDs on the wireline interface module. Otherwise the stations completes the boot process and the station control module's Station On LED lights.
12. A success message appears on successful software download.

**IMPORTANT**

If the station enters a frozen or locked state, the software modules have not been FLASHed properly. To recover, click **Erase Flash**, then repeat the download procedure. Click **Erase Flash** only if you have the software on hand to download to the station. Erasing FLASH renders the station inoperable until software is downloaded.

**NOTE**

In an IntelliRepeater network, when the software download has completed to one station, all other stations in the network are automatically crossloaded, through Ethernet, so that they are all running the same version of software.



# PL/DPL Codes

**Table A-1** Tone Private-Line (PL) Codes

Frequency (Hz)	Motorola Code	Frequency (Hz)	Motorola Code
67.0	XZ	136.5	4Z
69.3	WZ	141.3	4A
71.9	XA	146.2	4B
74.4	WA	151.4	5Z
77.0	XB	156.7	5A
79.7	WB	162.2	5B
82.5	YZ	167.9	6Z
85.4	YA	173.8	6A
88.5	YB	179.9	6B
91.5	ZZ	186.2	7Z
94.8	ZA	192.8	7A
97.4	ZB	203.5	M1
100.0	1Z	206.5	8Z
103.5	1A	210.7	M2
107.2	1B	218.1	M3
110.9	2Z	225.7	M4
114.8	2A	229.1	9Z
118.8	2B	233.6	M5
123.0	3Z	241.8	M6
127.3	3A	250.3	M7
131.8	3B		

**Table A-2** Digital Private-Line (DPL) Codes

Digital Codes	Digital Codes	Digital Codes	Digital Codes
023	143	315	532
025	152	331	546
026	155	343	565
031	156	346	606
032	162	351	612
043	165	364	624
047	172	365	627
051	205	371	631
054	223	411	645
065	226	412	662
071	243	413	664
072	244	423	703
073	245	431	712
074	251	432	723
114	261	445	731
115	263	464	732
125	265	466	734
131	271	503	743
132	306	506	754
134	311	516	

# dBm to Microvolts Conversion

**Table B-1** dBm to Microvolts Conversion

<b>dBm</b>	<b>Microvolts</b>	<b>dBm</b>	<b>Microvolts</b>
-80	22.3606	-106	1.1206
-81	19.9289	-107	0.9988
-82	17.7617	-108	0.8901
-83	15.8301	-109	0.7933
-84	14.1086	-110	0.7071
-85	12.5743	-111	0.6302
-86	11.2068	-112	0.5616
-87	9.9881	-113	0.5005
-88	8.9019	-114	0.4461
-89	7.9338	-115	0.3976
-90	7.0710	-116	0.3543
-91	6.3020	-117	0.3158
-92	5.6167	-118	0.2815
-93	5.0059	-119	0.2508
-94	4.4615	-120	0.2236
-95	3.9763	-121	0.1992
-96	3.5439	-122	0.1776
-97	3.1585	-123	0.1583
-98	2.8150	-124	0.1410
-99	2.5089	-125	0.1257
-100	2.2360	-126	0.1120
-101	1.9928	-127	0.0998
-102	1.7761	-128	0.0890
-103	1.5830	-129	0.0793

**Table B-1** dBm to Microvolts Conversion (continued)

<b>dBm</b>	<b>Microvolts</b>	<b>dBm</b>	<b>Microvolts</b>
-104	1.4108	-130	0.0707
-105	1.2574		

# Glossary

---

Term	Definition
Alignment	Adjustment procedures, usually aided by RSS program, that set the station operating parameters to meet the specifications; Includes deviation, power out, and wireline levels.
Archive Files	Codeplug backup file.
Base	Base station. The type of station in which transmit and receive frequencies, usually the same. Operates in simplex mode only.
Calibration	Method of adjusting a circuit to meet critical operating parameters.
Call Sign	FCC-assigned ID of the licensee. Typically in alphanumeric form and broadcast periodically during station operation.
Carrier Squelch	One of several methods of opening the receiver path and unmuting the audio path to the speaker. Other methods are PL, DPL, and ASTRO.
Channel	A pair of frequencies, transmit and receive, used for a single communications path.
Codeplug	The area of non-volatile memory in the station that stores the station configuration, calibration, and personality profiles.
COMX	The serial communications port(s) available on a PC. Usually COM1 through COM4.
Defaults	Data placed into RSS data fields either as a placeholder or as typical data for the particular field. Default data may be edited as necessary.
Dekey	Turn off the station transmitter.
Deviation	The amount of variance (+ or -) from the carrier frequency caused by audio or data modulation. Typically expressed in + or - kHz.

Term	Definition
Failsoft	A station operating mode entered when the trunking central controller is either unavailable or nonfunctional. This provides basic operation until the trunking central controller is available or becomes functional.
Field	Area on the display in which data may be entered or edited.
Full Duplex	Simultaneous transmit and receive.
Key	Turn on the station's transmitter.
Personality	Set of parameters, settings, and features that define the operation of a station. This includes specifics such as operating frequencies, output power, and squelch type.
Repeater	A type of station in which any signal received is subsequently transmitted. This requires different frequencies for transmit and receive.
SECURENET	Type of secure radio communications using a proprietary protocol for signaling and encryption/decryption.
Simulcast	Radio communications system in which voice/data to be transmitted is sent to multiple sites and transmitted simultaneously to provide wide area coverage.
Squelch	Methods of eliminating noise from the speaker when no received signal is present. Three common types of squelch are carrier (CSQ), PI, and DPL.
Transparent	Indicates that the station is equipped to operate in a digital system, but is not capable of encryption or decryption.
Trunking	Allocation of station resources by a central controller in accordance with configured rules. This allows a relatively small amount of station resources to be dynamically shared amongst subscribers.
Wireline	Typically a phone line connection between a console and a station.

# Acronyms

---

Acronym	Definition
AMSS	Automatic Multiple Site Selection
ASCII	American Standard Code Information Interchange
AES	Area Systems Engineer
COM	Communications port
COAM	Customer Owned and Maintained
CHAN	Channel
CONV	Conventional; conversation
CSQ	Carrier Squelch
CTCSS	Continuous Tone Coded Squelch System
DOS	Disk Operating System
DPL	Digital Private Line (coded squelch)
DRAM	Dynamic Random Access Memory
DTMF	Dual Tone Multiple Frequency
DVM	Digital Volt Meter
EPROM	Erasable Programmable Read-Only Memory
EEPROM	Electrically Erasable Programmable Read-Only Memory
FREQ	Frequency
FTR	Field Technical Representative
ID	Identification
kHz	kilohertz (1000 Hz)
LED	Light Emitting Diode

<b>Acronym</b>	<b>Definition</b>
LLGT	Low Level Guard Tone (typically 2175 Hz)
MHz	Megahertz (1,000,000 Hz)
MRSS	Motorola Radio Service Software
MSS	Motorola Service Station
NSO	National Service Organization
NST	National Service Training
PC	Personal Computer
PL	Private Line (coded squelch)
PROM	Programmable Read-Only Memory
PTT	Push To Talk
RAM	Random Access Memory
RSS	Radio Service Software
RX	Receive
TOT	Time Out Timer
TPL	Tone Private Line squelch
TX	Transmit



# Index

## A

- Access
  - Modem Requirements . . . . . 9-2
  - Modem, PC Configuration . . . . . 9-3
  - Modem, RSS PC Configuration Fields . . . . . 9-5
  - Modem, Station Configuration . . . . . 9-2
  - Remote Dial-Up . . . . . 9-1
- Access code table
  - 6809 trunking field definitions . . . . . 3-15
  - Conventional field definitions . . . . . 3-14
  - programming for 6809 trunking systems . . . . . 3-15
  - programming for conventional systems . . . . . 3-13
- Alignment
  - Alignment Procedures . . . . . 6-2
  - ASTRO Bit Error Rate . . . . . 3-90
  - ASTRO Test Pattern Generation . . . . . 3-85
  - ASTRO Tx Align and Test . . . . . 3-82
  - AstroTAC Comparator
    - Battery Equalization . . . . . 4-10
    - Reference oscillator . . . . . 4-10
  - Astro-TAC comparator
    - Overview . . . . . 4-9
  - Battery Equalization . . . . . 3-73
  - Overview . . . . . 3-54
  - Post-Repair Alignment Overview . . . . . 6-1
  - Power Output Alignment Procedure . . . . . 6-4
  - Power Output Alignment Procedure, 350W VHF Stations . . . . . 6-7
  - Reference Modulation Alignment Procedure . . . . . 6-14
  - Reference oscillator . . . . . 3-75
  - RSSI . . . . . 3-68
  - Rx Wireline . . . . . 3-55
  - Squelch Adjust . . . . . 3-71
  - TDATA Calibration . . . . . 3-88
  - Tx Deviation Alignment Procedure, 350W VHF Stations 6-11
  - Tx Wireline . . . . . 3-55
- Archive File
  - Opening . . . . . 2-24
- Archive, Saving Data to . . . . . 2-22
- ASTRO Bit Error Rate, Reports . . . . . 3-90
- ASTRO Test Patterns, Generation . . . . . 3-85
- ASTRO Tx, Align and Test procedure . . . . . 3-82
- Auxiliary Input
  - Programming . . . . . 10-2
- Auxiliary Inputs . . . . . 10-2
  - Fields . . . . . 10-3
- Auxiliary Output
  - Programming . . . . . 10-5
- Auxiliary Outputs . . . . . 10-4
  - Fields . . . . . 10-5

## B

- Backplane ID
  - Reading from comparator . . . . . 7-18
- Battery, Equalization . . . . . 3-73, 4-10
- Bit Error Rate, Reports . . . . . 3-90

## C

- Codeplug
  - Getting Size . . . . . 2-21

Opening an Archive . . . . .	2-24
Printing a Report . . . . .	5-31
Reading the Station. . . . .	2-14
Reports . . . . .	5-31
Reports, Saving . . . . .	5-32
Verifying Station Data . . . . .	3-3
Writing to Station . . . . .	2-20
Comparator	
Analog Voting System screen . . . . .	4-7
Analog Voting System screen fields . . . . .	4-7
Conventional System screen . . . . .	4-5
Conventional System screen fields . . . . .	4-5

Hardware Configuration screen . . . . .	4-3
Hardware Configuration screen fields . . . . .	4-4
Optimizing. . . . .	4-1
Port Control screen . . . . .	4-8
Port Control screen fields . . . . .	4-8
Programming . . . . .	4-1, 4-3
Retrieving Backplane ID . . . . .	7-18
Smartzone System screen . . . . .	4-6
Smartzone System screen fields . . . . .	4-6
Verifying configuration. . . . .	4-2
Compatibility	
Firmware . . . . .	7-1

**D**

---

Date and Time	
Setting. . . . .	5-30
dBm to Microvolts Conversion Table . . . . .	B-1
Diagnostics	
AstroTAC Comparator	
Fan check . . . . .	5-34
Overview. . . . .	3-93, 5-1
Dial-Up . . . . .	9-1

Modem Requirements . . . . .	9-2
PC Configuration . . . . .	9-3
RSS PC Configuration Fields. . . . .	9-5
Station Configuration . . . . .	9-2
Disabling	
Remote Station Disabling . . . . .	5-33
DPL codes . . . . .	A-1

**E**

---

Enabling	
----------	--

Remote Station Enabling. . . . .	5-33
----------------------------------	------

**F**

---

Feature Summary, RSS . . . . .	2-1
File	
Maintenance . . . . .	2-21
Saving to Archive. . . . .	2-22
Firmware	

Compatibility . . . . .	7-1
Features and System Capabilities . . . . .	7-22
RSS Program Version Relationship . . . . .	7-2
Upgrade. . . . .	7-1

**I**

---

Installing RSS. . . . .	2-4
-------------------------	-----

**M**

---

Metering, Screens . . . . .	5-2
-----------------------------	-----

## N

Network Operation		Setting the IP Address . . . . .	3-6
Setting the Date and Time . . . . .	3-8	Setting the MAC Address . . . . .	3-7

## O

Optimization		Verifying Station Data . . . . .	3-3
Date and Time Setting . . . . .	3-8	Wireline Configuration . . . . .	3-9
IP Address Setting . . . . .	3-6	Wireline Configuration Fields . . . . .	3-10
MAC Address Setting . . . . .	3-7	Optimizing	
Overview . . . . .	3-1	Comparator . . . . .	4-1
Post-Optimization Checkout . . . . .	3-93	Programming . . . . .	4-3
Required Equipment . . . . .	3-2	Overview . . . . .	9-1
StationType Program Overview . . . . .	3-5		

## P

Password		Erasing, Remote . . . . .	8-5
Activation . . . . .	8-1	Features . . . . .	8-2
Bypassing . . . . .	8-6	Protection Overview . . . . .	8-1
Changing . . . . .	8-3	Timeout . . . . .	8-1
Creation . . . . .	8-2	PC Requirements . . . . .	2-4
Erasing, Local . . . . .	8-4	PL Codes . . . . .	A-1

## R

Reference Oscillator, Alignment . . . . .	3-75, 4-10	Saving a Codeplug Report . . . . .	5-32
Remote		Status . . . . .	5-3
Disabling a Station . . . . .	5-33	RSS	
Enabling a Station . . . . .	5-33	Connecting PC to Station . . . . .	2-11
Repair		Exiting . . . . .	2-13
Alignment Procedures . . . . .	6-2	Feature Summary . . . . .	2-1
Output Power Alignment Procedure . . . . .	6-4	Firmware Relationship . . . . .	7-2
Output Power Alignment Procedure, 350W VHF Stations . . . . .	6-7	Installation Procedure . . . . .	2-4
Post-Repair Alignment Overview . . . . .	6-1	Launching . . . . .	2-12
Reference Modulation Alignment Procedure . . . . .	6-14	PC Requirements . . . . .	2-4
Tx Deviation Alignment Procedure, 350W VHF Stations 6-11		Program Versions Compatibility . . . . .	7-16
Reports		Screen Overview . . . . .	2-17
Codeplug . . . . .	5-31	User Interface Description . . . . .	2-2
Printing Codeplug Report . . . . .	5-31	RSSI	
		Alignment . . . . .	3-68
		Rx Wireline, Alignment . . . . .	3-55

## S

Security		Password Bypassl . . . . .	8-6
Password Activation . . . . .	8-1	Password Change . . . . .	8-3

Password Creation . . . . .	8-2
Password Erasure, Local . . . . .	8-4
Password Erasure, Remote . . . . .	8-5
Password Features . . . . .	8-2
Password Protection . . . . .	8-1
Password Protection Overview. . . . .	8-1
Password timeout . . . . .	8-1
SLIP Naming Convention . . . . .	11-33
Software	
Versions . . . . .	7-17, 7-18
Software Downloading	
Downloading Software to Station, 6809 Controller Systems . . . . .	11-40
Downloading Software to Station, IntelliRepeater Systems . . . . .	11-44
Installing Dial-Up Modem in Windows XP Professional 11-15	
Installing Null Modem in Windows XP Professional 11-3	
Loading Station Software to PC . . . . .	11-40
Overview . . . . .	11-1
PC Preparation . . . . .	11-3
Prerequisites . . . . .	11-2
RSS SLIP Naming Convention . . . . .	11-33
Station Connection, Ethernet . . . . .	11-35

Station Connection, Overview . . . . .	11-34
Station Connection, Remote Dial-Up . . . . .	11-37
Station Connection, Serial . . . . .	11-34
Station Connection, Zone Controller Link . . . . .	11-37
Software Version	
Station . . . . .	5-30
Squelch Adjust, Alignment . . . . .	3-71
State/Action Tables . . . . .	10-6
Fields . . . . .	10-9
Overview . . . . .	10-7
Programming . . . . .	10-8
Station	
Retrieving Station ID . . . . .	7-17
Status	
Astro-TAC Comparator	
Panel Screen . . . . .	5-28
Messages . . . . .	5-1
Messages, Station Generated . . . . .	5-6
Metering Screens . . . . .	5-2
Overview . . . . .	5-1
Panel Button Definitions . . . . .	5-27
Panel Screen . . . . .	5-26
Reports Screen . . . . .	5-3
Station Software Versions . . . . .	5-30

**T**

TDATA Calibration, Alignment . . . . .	3-88
Tx Wireline, Alignment . . . . .	3-55

**U**

Upgrade	
Firmware . . . . .	7-1
Performing . . . . .	7-19
User Interface Description . . . . .	2-2

**W**

Wildcard	
Auxiliary Input Fields . . . . .	10-3
Auxiliary Input, Programming . . . . .	10-2
Auxiliary Inputs . . . . .	10-2
Auxiliary Output . . . . .	10-4
Auxiliary Output Fields . . . . .	10-5
Auxiliary Output, Programming . . . . .	10-5
Overview . . . . .	10-1
State/Action Tables . . . . .	10-6
State/Action Tables, Fields . . . . .	10-9
State/Action Tables, Overview . . . . .	10-7
State/Action Tables, Programming . . . . .	10-8
Wireline	
Configuration . . . . .	3-9
Configuration Fields . . . . .	3-10