

# TM 11-6665-228-15

DEPARTMENT OF THE ARMY TECHNICAL MANUAL

---

OPERATOR , ORGANIZATIONAL, DS, GS, AND DEPOT  
MAINTENANCE MANUAL  
INCLUDING REPAIR PARTS AND SPECIAL TOOLS LISTS

**RADIAC SET AN/PDR-27G**

---

HEADQUARTERS, DEPARTMENT OF THE ARMY  
MARCH 1966



**Changes in force: C 1 and C 2**

TM 11-6665-228-15  
C 2

CHANGE }  
No. 2 }

HEADQUARTERS  
DEPARTMENT OF THE ARMY  
WASHINGTON, D. C., 17 October 1973

Operator's, Organizational, Direct **Support**, General  
Support, and Depot Maintenance Manual  
Including Repair Parts and Special Tools List

**RADIAC SET AN/ PDR-27G**

TM 11-666 5-228-15, 9 March 1966, is changed as follows:

*Page A-I*, paragraph **A-3**. Delete paragraph **A-3** and substitute :

**A-3.** Forms and Records

*a. Reports of Maintenance and Unsatisfactory Equipment.* Maintenance forms, records, and reports which are to be used by maintenance personnel at all maintenance levels are listed in and prescribed by TM 38-750.

*b. Report of Packaging and Handling Deficiencies.* Fill out and forward DD Form 6 (Report of Packaging and Handling Deficiencies) as prescribed in AR 700-58 (Army) /NAVSUP Pub 378 (Navy) /AFR 71-4 (Air Force) /and MCO P4030.29 (Marine Corps).

*c. Discrepancy in Shipment Report (DISREP) (SF 361).* Fill out and forward Discrepancy in Shipment Report ( DISREP) (SF 361 ) as prescribed in AR 55-38 (Army) /NAVSUP Pub 459 (Navy) /AFM 75-34 (Air Force) /and MCO P4610.19 (Marine corps) .

**A-4.** Reporting of Equipment Publication Improvements

The reporting of errors, omissions, and recommendations for improving this publication by the individual user is encouraged. Reports should be submitted on DA Form 2028 (Recommended Changes to Publications) and forwarded direct to Commander, US Army Electronics Command, ATTN: AMSEL-MA-C, Fort Monmouth, NJ 07703.

**A-5.** items Comprising an Operable **Radiac** Set AN/  
**PDR-27G**

FSN	QTY	Nomenclature, part No., and mfr code	Fig. No.
		NOTE The part number is followed by the applicable <b>5-digit</b> Federal supply code for manufacturers (FSCM) identified in <b>SB 708-42</b> and used to identify manufacturer, distributor, or Government agency, etc.	
		NOTE Dry batteries shown are used with the equipment but are not considered part of the equipment. They will not be preshipped automatically but are to be requisitioned in quantities necessary for the particular organization in accordance with <b>SB 11-6</b> .	
6665-543-1443		<b>Radiac Set AN/ PDR-27G</b> consisting of:	
6665492-7466	1	H a r n e s s <b>ST-125 A/PDR-27E</b>	1-1
6665-515-5891	1	Radiacmeter <b>IM-74B/PDR-27C</b> including:	1-3
6135-164-8753		Battery, Dry <b>BA-401/U</b> , (For reference only)	1-1
6135-164-8754		Battery, Dry <b>BA-413/U</b> , (For reference only)	3-2
6136-164-8768		Battery, Dry <b>BA-416/U</b> , (For reference only)	1-1
6665-832-6159	1	Radioactive Test Sample <b>MX-7338/PDR-27R</b>	3-3
5120-383-0964	1	Wrench, Open End, Fixed, 515 <b>A174, 99546;</b> or <b>MI-3, 04787</b>	1-1
5120-224-2504	1	Wrench, Socket Head, Hex: 5/64 in. across flats, 1 31/32 in. <b>lg</b> , for No. 8 setscrew	1-1

## APPENDIX II

### BASIC ISSUE ITEMS LIST (BIIL) AND ITEMS TROOP INSTALLED OR AUTHORIZED LIST (ITIAL)

---

#### Section I. INTRODUCTION

##### 1. Scope

This appendix lists only basic issue items required by the *crew*/operator for installation, operation, and maintenance of Radiac Set AN/PDR-27G.

##### 2. General

This Basic Issue Items and Items Troop Installed or Authorized List is divided into the following sections:

a. *Basic Issue Items List—Section II.* A list, in alphabetical sequence, of items which are furnished with, and which must be turned in with the end item.

b. *Items Troop Installed or Authorized List—Section III.* Not applicable.

##### 3. Explanation of Columns

The following provide an explanation of columns found in the tabular listings:

a. *Illustration.* This column is divided as follows:

(1) *Figure Number.* Indicates the figure number of the illustration in which the item is shown.

(2) *Item Number.* Not applicable.

b. *Federal Stock Number.* Indicates the Federal stock number assigned to the item and will be used for requisitioning purposes.

c. *Part Number.* Indicates the primary number used by the manufacturer (individual, company, firm, corporation, or government activity), which controls the design and characteristics of the item by means of its engineering drawings, specifications, standards, and inspection requirements, to identify an item or range of items.

d. *Federal Supply Code for Manufacturer (FSCM).* The FSCM is a 5-digit numeric code used to identify the manufacturer, distributor, or Government agency, etc., and is identified in SB 708-42.

e. *Description.* Indicates the Federal item name and a minimum description required to identify the item.

*f. Unit of Measure (tJ/M).* Indicates the standard of basic quantity of the listed item as used in performing the actual maintenance function. This measure is expressed by a two-character alphabetical abbreviation, (e.g., ea, in., pr, etc). When the unit of **measure** differs from the unit of issue, the lowest unit of issue that will satisfy the required units of measure will be requisitioned.

*g. Quantity Furnished with Equipment (Basic Issue Items Only).* Indicates the quantity of the basic issue item furnished with the equipment.

## Section II. BASIC ISSUE ITEMS LIST

(1) Illustration		(2) Federal stock number	(3) Part number	(4) FSCM	(5) Description  Usable on code	(6) Unit of meas	(7) Qty furn with equip
(A) Fig. No.	(B) Item No.						
1-1		6665-547-1040			CASE CY-963A,B,C/PDR-27A	EA	1

By Order of the Secretary of the Army:

**CREIGHTON W. ABRAMS**  
*General, United States Army*  
*Chief of Staff*

**Official:**

VERNE L. BOWERS  
*Major General, United States Army*  
*The Adjutant General*

Distribution:

To be distributed in accordance with DA Form 12-60, (**qty**  
**rq** block no. **33**) Operator maintenance requirement for AN/  
**PDR-27G.**



*P. 11-6665-2!28-15*  
*6/1/68*

TM 11-6665-2!28-15

C I

CHANGE }  
No. 1 }

HEADQUARTERS  
DEPARTMENT OF THE ARMY  
WASHINGTON, D. C., 12 April 1968

Operator, Organizational, DS, GS, and Depot Maintenance  
Manual Including Repair Parts and Special Tool Lists  
**RADIAC SET AN/PDR-27G**

TM 11-666%228-15, 9 March 1966, is changed as follows:

- ✓ The title of the manual is changed as shown above.
- ✓ Page ii, warning notice, last sentence. Change "AR 755-380" to AR 755-15.
- Page A-1. Delete paragraphs A-2 and A-3 and substitute:

**A-2. Indexes of Equipment Publications**

- a. DA Pam 310-4. Refer to the latest issue of DA Pam 310-4 to determine whether there are new editions, changes, or additional publications pertaining to the equipment.
- b. DA Pam 310-7. Refer to the latest issue of DA Pam 310-7 to determine whether there are modification work orders (M WO's) pertaining to the equipment.

**A-3. Forms and Records**

- a. ~~Reports of Maintenance and Unsatisfactory Equipment. Use equipment forms and records in accordance with instructions in TM 38-750.~~
- b. ~~Reporting of Packaging and Handling Diciencies. Fill out and forward DD Form 6 (Report of Packaging and Handling Deficiencies) as prescribed in AR 700-58 (Army), NAVSUP Pub 3378 (Navy), AFR 71-4 (Air Force), and MCO P4030.29 (Marine Corps).~~
- c. ~~Discrepancy in Shipment Report (DISREP) (SF 861). Fill out and forward Discrepancy in Shipment Report (DISREP) (SF 361) as prescribed in AR 55-38 (Army), NAVSUP Pub 459 (Navy), AFM 75-34 (Air Force), and MCO P4610.19 (Marine Corps).~~
- d. ~~Report of Equipment Publication Improvements. Report of errors, omissions, and recommendations for improving this publication by the individual user is encouraged. Reports should be submitted on DA Form 2028 (Recommended Changes to DA Publications) and forwarded direct to Commanding General, U.S. Army Electronics Command, APTN: AMSEL-ME-NMP-AD, Fort Monmouth, N.J. 07703.~~

✓ Page 4-2, section 4, paragraph 2, step 8. Add the following after step 8:

Note. The aural indications will be heard only when radiation is being detected.

- ↳ Step 8.1. Turn the range switch to BATT. COND.
- &- Page 4-4, section 4, paragraph 4, step 7. Delete the “CAUTION” notice and substitute:

Caution: The batteries must be removed if the equipment is being placed in storage or in a standby condition. Any deviation, to meet a particular situation, must be approved by the individual commander.

- ↳ Page 6-0, section 6, paragraph 3b. Delete the “CAUTION” notice.
- ↳ Page 6-3, section 6, table 6-2. In the “Procedure” column, after sequence No. 2, add:

**Caution:** The batteries must be removed if the equipment is in storage or in a standby condition.

- ↳ Page 6-7, section 6, table 6-4. Sequence No. 3, “Procedure” column. Change “DA Pam 310-4” to DA Pam 310-7.

- ↳ Page 6-8, section 6, table 6-4. Sequence No. 5, “References” column,

- b. Delete “SB 11-573”.

Add the following after sequence No. 5:

<i>Sequence No.</i>	<i>Item to be inspected</i>	<i>Procedure</i>	<i>References</i>
● 6-----	Test sample -----	Test sample has identification tag and meets minimum leakage requirements as determined by wipe test.	Para 9.

- Wipe test is to be performed semiannually (TB 3-6665-201-12).

Add paragraph 9 after table 6-4.

## 9. Wipe Test

The purpose of the wipe test is to detect radioactive contamination (leakage) of the test sample. This test *must* be performed semiannually under the direct supervision of the Radiological Protection Officer. To perform the wipe test, refer to TB 3-6665-201-12.

**Note.** In addition to the wipe test procedures, TB 3-6665-201-12 also contains data pertaining to inspection, tagging, handling, and storing of test samples.

Page 7-11, section 7, paragraph 6. Make the following changes:

Delete the paragraph heading and substitute: 6. DEPOT CALIBRATION. Subparagraph a(1). Change “AN/UDM-1” to AN/UDM-1 or AN/UDM-1A. Subparagraph 6, step 2, line 1. Change “AN/UDM-1” to AN/UDM-1 or AN/UDM-1A.

Page 7-14. Add paragraph 6.1 after paragraph 6:

### 6.1. Calibration With TS-784/PD or TS-784A/PD

Calibrator, Radiac TS-784/PD or TS-784A/PD may be used to calibrate the AN/PDR-27G. Instructions for using the TS-784/PD or TS-784A/PD during calibration of the AN/PDR-27G are contained in TM 11-6666-204-12.

Page 7-25. Add sections 8 and 9 after section 7.

# SECTION 8

## DEPOT OVERHAUL STANDARDS

### 1. Applicability of Depot Overhaul Standards

The tests outlined in this section are designed to measure the performance capability of a repaired equipment. Equipment that is to be returned to stock should meet the standards given in these tests.

### 2. Applicable References

*a. Repair Standards.* Applicable procedures of the depot performing these tests and the general standards for repaired electronic equipment given in TB SIG 355-1, TB SIG 355-2, and TB SIG 355-3 form a part of the requirements for testing this equipment.

*b. Modification Work Orders.* Perform all modification work orders applicable to this equipment before making the tests specified. DA Pam 310-7 lists all available MWO's.

### 3. Test Equipment Required

The following test equipments are required to determine whether the equipment complies with the depot overhaul standards.

	<i>Item</i>	<i>Technical manual</i>
Radiac Calibrator Set	AN/UDM-1 .....	TM 11-1176.
	or	
Radiac Calibrator Set	AN/UDM-1A .....	TM 11-662*217-15.
Test Set, Electron Tube	AN/USM-23 .....	
Test Set, Electron Tube	TV-2(*)/U* .....	TM 11-6675-316-12.
	. TV-2(*)/U represents the TV-2/U, TV-2A/U, TV-2B/U, or TV-2C/U.	

### 4. General Test Requirements

*a.* Perform all tests at normal room temperature.

*b.* Before testing the equipment, allow 5 minutes for it to reach a stable temperature.

### 5. Operational Test

*a.* Obtain four new batteries (one BA-416/U, one BA-413/U, and two BA-401/U), and insert them into the battery compartment (sec. 3, para 2).

*b.* Set the range switch (fig. 1-3) to BATT. COND.; the meter must indicate to the right of the line marked BATT on the meter face.

*c.* Press the pushbutton switch (part of the pushbutton switch assembly); the meter face must be illuminated by the internal lamp.

*d.* Connect the H-43B/U to the headset jack, and set the range switch to 500. Hold the test sample under the radiacmeter (fig. 3-3); a clicking sound must be heard in the H-43B/U.

## 6. Removal of Tubes V101 Through V104

To test tubes V101 through V104 (para 7), remove them from the equipment. Tube V101 (BS-2) is secured to the inside of the radiacmeter by two clips (fig. 1-5); tube V102 (BS-1) is located inside the radiac detector (fig. 7-6); tubes V103 (BS-101) and V104 (3V4) are plugged into tube sockets inside the radiacmeter (fig. 1-6). Remove these tubes as follows:

- a. Position the radiacmeter so that the carrying handle is at the top (fig. 1-3).
- b. Loosen the six screws that secure the panel to the housing.
- c. Grasp the carrying handle, lift the panel from the housing, and turn the panel over so that the bottom of the panel is exposed (figs. 1-5 and 1-6).
- d. Lift tube V101 from the clip that secures it to the panel.
- e. Slide the connector off the cap on tube V103, and pull tube V103 from its socket.
- j. Pull the spring holder from the top of tube V104, and pull tube V104 from its socket.
- g. Remove tube V102 from the radiac detector (sec. 7, para 7a).

## 7. Testing Tubes V101 Through V104

a. Test tube V104 with the TV-2(\*)/U. Tube V104 must have no short circuits or excessive gas, and its transconductance must exceed the minimum limit specified on the tube test data roll chart in the TV-2(\*)/U.

*Note.* The AN/USM-23 is a tube tester that is used to test tubes V101, V102, and V103. Instructions for use of the AN/USM-23 are contained in its attached instruction book.

b. Test tube V101 with the AN/USM-23. Results must be as follows:

(1) The H COUNTING RATE index associated with the radiation intensity control on the AN/USM-23 must indicate GOOD for the gamma response test.

(2) The indicating meter on the AN/USM-23 must indicate GOOD for the relative plateau slope and the gamma sensitivity test.

c. Test tube V102 with the AN/USM-23. Results must be as follows:

(1) The H COUNTING RATE index associated with the radiation intensity control on the AN/USM-23 must indicate GOOD for the gamma response test.

(2) The indicating meter on the AN/USM-23 must indicate GOOD for the relative plateau slope and the gamma sensitivity test.

d. Test tube V103 with the AN/USM-23; the K REGULATOR TEST index associated with the regulator test control must indicate GOOD for the operating voltage test and the voltage regulation test.

e. Replace tube V102 in the radiac detector (sec. 7, para 7b).

**f.** Replace tubes **V101, V103, and V104** in the **radiacmeter** (fig. 1-5 and HI); replace the spring holder on the top of tube **V104**, and elide the connector on the cap of tube **V103**.

**g.** Secure the panel (fig. 1-3) to the housing with the six screws.

## 8. Checking Calibration

**Note.** Before checking the calibration of the **AN/PDR-27G**, the positions of the **X-axis** bar, the **Y-axis** bar, and the height control of the **radiac** calibrator set (**AN/UDM-1** or **AN/UDM-1A**) must be determined (TM 11-1176 or TM 11-6665-217-15).

Check the calibration of each of the four ranges of the **radiacmeter** at four-fifths (0.4, 4, 40, end 400) of full-scale value with the **radiac** calibrator set. The meter indication must be four-fifths of full-scale value  $\pm 20$  percent on each range. Instructions for operating the **radiac** calibrator set are contained in TM 11-1176 (**AN/UDM-1**) or TM 11-6665-217-15 (**AN/UDM-1A**).

# SECTION 9

## DEMOLITION OF MATERIEL TO PREVENT ENEMY USE

### 1. Authority for Demolition

The demolition procedures given in paragraph 2 will be used to prevent the enemy from using or salvaging this equipment. Demolition of the equipment will be accomplished only upon the order of the commander.

### 2. Methods of Destruction

**u. Smash.** Use sledges, axes, hammers, **crowbars**, and any other heavy tools available to smash the interior units of the sets.

(1) Remove the cover from the case casting, and remove the batteries.

(2) Use the heaviest tool available to smash the dial, knobs, **batteries**, and tubes; smash as many of the exposed parts of the cover as possible.

**Warning:** Be extremely careful with **explosives** and incendiary devices. Use these items only when the need is urgent.

**b. Burn.** Burn the technical manuals first. Burn as much of the equipment as is flammable; use gasoline, oil, **flamethrowers**, and similar materials. Pour gasoline on the internal wiring and ignite it. Use a **flamethrower** to burn spare parts or pour gasoline on the spares and ignite them. Use incendiary grenades to complete the destruction of the set.

**c. Dispose.** Bury or scatter destroyed parts, or throw them into nearby **waterways**. This is particularly important if a number of parts have not been completely destroyed,

### 3. Handling and Disposal of Radioactive Material

**Wanting:** Follow the procedures for **safe** handling and disposal of radioactive materials as directed **by—**

- a. TB SIG 225.
- b. AR 706-52.
- c. AR 755-15.
- d. TB 2-6665-201-12.

Page **AI-1**, appendix 1. Delete and substitute:

## APPENDIX I

### REFERENCES

The following are applicable references that should be available to the **operator and** maintenance personnel of **Radiac Set AN/PDR-27G:**

AR 700-52	Licensing and Control of Sources of Ionizing Radiation.
AR 755-15	Disposal of Unwanted Radioactive Material.
DA Pam 310-4	Index of Technical Manuals, Technical <b>Bulletins</b> , Supply Manuals (types <b>7,8, and 9</b> ), <b>Supply Bulletins</b> , and <b>Lubrication Orders</b> .
DA Pam 310-7	U.S. Army <b>Equipment Index of Modification Work Orders</b> .
SB 38-100	<b>Preservation, Packaging and Packing Materials, Supplies, and Equipment Used by the Army</b> ,
TB 3-6665-201-12	<b>Radioactive Test Sample, Radium 226, Gamma, MX-1083B/PDR-27</b> .
TB 1 1-6625-274-14/1	Test Data for Electron Tube Test Sets <b>TV-7/U, TV-7A/U, TV-7B/U, and TV-7D/U</b> .
TB SIG 225	Identification and Handling of Radioactive Signal Items.
TB SIG 355-1	Depot Inspection Standard for Repaired Signal Equipment.
TB SIG 855-2	Depot Inspection Standard for Refinishing Repaired Signal Equipment.
TB SIG 855-3	Depot <b>Inspection</b> Standard for Moisture and Fungus Resistant Treatment.
TB SIG 364	<b>Field</b> Instructions for Painting and <b>Preserving</b> Electronics Command Equipment.
TM 11-1176	<b>Radiac Calibrator Set AN/UDM-1</b> .
TM 11-1214	Instruction Book for <b>Oscilloscope OS-8A/U</b> .
TM 11-1214A	<b>Oscilloscope OS-8C/U</b> .

- TM 11-5965-247-12P** Operator and Organizational Maintenance Repair Parts and Special Tools List and Maintenance Allocation Chart: Headset-Electrical **H-43B/U**.
- TM 11-5965-247-35P** Field and Depot Maintenance Repair Parts and Special Tools List: Hendaet-Electrical **H-43B/U**.
- TM 11-6625--274-12** Operator's and Organizational Maintenance Manual: Test Sets, Electron Tube **TV-7/U, TV-7A/U, TV-7B/U, a n d TV-7D/U**.
- TM 11-6625-316-12** Operator and Organizational Maintenance Manual: Test Sets, Electron Tube **TV-2/U, TV-2A/U, TV-2B/U, and TV-2C/U**.
- TM 11-6625-366-15** Organizational, DS, GS, and Depot Maintenance Manual: **Multimeter TS-352B/U**.
- TM 11-6665-204-12** Operator and Organizational Maintenance Manual: Calibrator Sets, **Radiac TS-784/PD and TS-784A/PD**.
- TM 11-6665-217-15** Organizational, DS, GS, and Depot Maintenance Manual: **Radiac Calibrator Set AN/UDM-1A**.
- TM 38-750** Army Equipment Record Procedures.

By Order of the Secretary of the Army:

HAROLD K. JOHNSON,  
*General, United States Army,  
 Chief of Staff.*

Official:

KENNETH G. WICKHAM,  
*Major General, United States Army,  
 The Adjutant General.*

Distribution:

To be distributed in accordance with DA Form 12-50 requirements for Operator, **AN/PDR-27G Radiac Set**.





WARNING

HIGH VOLTAGE

is present in this **equipment**

Geiger **-Muller** tubes **BS-1** (V102, fig. 7-6) and **BS-2** (V101, fig. 1-6)  
and high-voltage **regulat 'r BS-101** ( V103 ) have terminal voltages as high  
as 700 volts dc; be careful when working on this **equipment.**

**DON'T** TAKE CHANCES!

**WARNING**  
RADIATION HAZARD

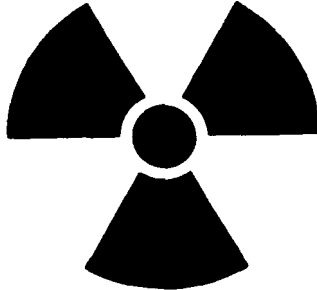

**STD-RW-2**

Ra 226

The items listed below contain radioactive material:

Item	<u>Manufacturer</u>	<u>Isotope</u>	<u>Quantity per tube (Microcuries)</u>
Radioactive Test Sample MX-1083B/PDR-27	N/A	Ra 226	5.0
Tube -type 5962	Electric products	Ni 63	3.0
	Raytheon	co 60	0. 0067
	Victoreen	Ni 63	0.001
	Anton Electric	c 14	1.0

Tube -type 5962 is hazardous when broken; see qualified medical personnel and the Safety Direct or if you are exposed to or cut by a broken tube. Use extreme care when replacing this tube, and follow safe procedures during handling, storage, and disposal (AR 700-52, AR 755-<sup>15</sup>~~386~~, and TB Sig 225).

Paragraph	SECTION A - INTRODUCTION	Page
A-1.	Scope . . . . .	A-1
A-2.	Index of Publications . . . . .	A-1
A-3.	Forms and Records . . . . .	A-1

SECTION 1 - GENERAL DESCRIPTION

1.	Purpose and Basic Principles . . . . .	1-1
2.	Description of Units . . . . .	1-3
	Case CY-963C/PDR-27A . . . . .	1-3
a.	Radiacmeter IM-74B/PDR-27C . . . . .	1-3
c.	Radiac Detector DT-106/PDR-27G . . . . .	1-8
d.	Headset H-43B/U . . . . .	1-9
e.	Harness ST-125A/PDR-271 . . . . .	1-9
f.	Radioactive Test Sample MX-1083B/PDR-27 . . . . .	1-10
g.	Equipment Maintenance Parts . . . . .	1-11
3.	Reference Data . . . . .	1-11
4.	Equipment Similarities . . . . .	1-13

SECTION 2 - THEORY OF OPERATION

1.	Radioactivity and Its Detection . . . . .	2-0
a.	Introduction . . . . .	2-0
b.	Atomic Radiation . . . . .	2-0
c.	Detection of Radiation . . . . .	2-0
d.	Measurement of Radiation . . . . .	2-1
2.	General Circuit Description . . . . .	2-2
3.	Circuit Analysis . . . . .	2-3
a.	Detector Circuit . . . . .	2-3
b.	Pulse Shaper and Amplifier Circuit . . . . .	2-4
c.	Indicating Circuit . . . . .	2-6
d.	Range Switch Circuits . . . . .	2-7
e.	Filament Power Supply Circuit . . . . .	2-7
f.	High-Voltage Power Supply Circuit . . . . .	2-9
g.	Regulated Plate Voltage Power Supply Circuit . . . . .	2-10
h.	Meter Illumination Circuit . . . . .	2-11

SECTION 3 - INSTALLATION

1.	Unpacking . . . . .	3-0
2.	Installation . . . . .	3-0
3.	Initial Testing . . . . .	3-1

\*This manual supersedes so much of TM 11-6665-201-12P, dated 10 October 1960, and TM 11-6665-201-35P, dated 10 October 1960, as pertains to Radiac Set AN/PDR-27G.

Paragraph		Page
SECTION 4 - OPERATION		
1.	General . . . . .	4-1
2.	Starting the Equipment . . . . .	4-1
3.	Radiation Detection and Measurement . . . . .	4-2
4.	Stopping the Equipment . . . . .	4-3
5.	Summary of Operation . . . . .	4-4
SECTION 5 - OPERATOR' S MAINTENANCE		
1.	Battery Check . . . . .	5-1
2.	Emergency Maintenance . . . . .	5-1
SECTION 6 - PREVENTIVE MAINTENANCE		
1.	Scope of Operator's Preventive Maintenance . . . . .	6-0
2.	Materials Required . . . . .	6-0
3.	Operator's Preventive Maintenance . . . . .	6-0
4.	Operator's Preventive Maintenance Checks and Services Periods . . . . .	6-1
5.	Cleaning . . . . .	6-4
6.	Organizational Preventive Maintenance . . . . .	6-4
7.	Monthly Maintenance . . . . .	6-4
8.	Quarterly Maintenance . . . . .	6-6
SECTION 7 - CORRECTIVE MAINTENANCE		
1.	General . . . . .	7-1
2.	Theory of Localization . . . . .	7-1
3.	Voltage-Resistance Chart . . . . .	7-3
4.	Waveform Chart . . . . .	7-3
5.	Trouble Shooting Chart . . . . .	7-5
6.	Calibration . . . . .	7-11
	a. General . . . . .	7-11
	b. Calibration Procedure . . . . .	7-12
7.	Removal and Replacement of Parts . . . . .	7-14
	a. Removal of V102 . . . . .	7-14
	b. Replacement of V102 . . . . .	7-15
	c. Replacing High Voltage Amplifier V10k (3V4 ) Tube . . . . .	7-16
	d. Removal and disassembly of Z101 . . . . .	7-16
	e. Re-assembly and replacement of Z101 . . . . .	7-17
8.	Component Characteristics . . . . .	7-19

Paragraph	Page
APPENDIX I. REFERENCES . . . . .	AI-1
II. BASIC ISSUE ITEMS LIST . . . . .	AII-1
III. MAINTENANCE ALLOCATION . . . . .	AIII-1
IV. ORGANIZATIONAL, DIRECT AND GENERAL SUPPORT AND DEPOT REPAIR PARTS LISTS . . . . .	AIV-1

## LIST OF ILLUSTRATIONS

Figure	Title	Page
SECTION 1 - GENERAL DESCRIPTION		
1-1	Radiac Set AN/PDR-27G . . . . .	viii
1-3	Radiacmeter IM-74B/PDR-27C. . . . .	1-6
1-4	Radiacmeter Waterproof Housing . . . . .	1-7
1-5	Radiacmeter Panel, Right Side and Rear. . . . .	1-8
1-6	Radiacmeter Panel, Left Side and Rear. . . . .	1-9
1-3	Radiacmeter, Showing Calibration Port and Push Button Assembly . . . . .	1-10
1-8	Push Button Switch Assembly, Exploded View . . . . .	1-11
SECTION 2 - THEORY OF OPERATION		
2-1	Typical Geiger-Muller Tube. . . . .	2-1
2-2	Radiac Set AN/PDR-27G, Block Diagram . . . . .	2-2
2-3	Detector Circuit . . . . .	2-3
2-4	Pulse Shaper and Amplifier Circuit . . . . .	2-5
2-5	Indicating Circuit . . . . .	2-7
2-6	Circuit Connections for Different Positions of S101. . . . .	2-8
2-7	High-Voltage Power Supply Circuit . . . . .	2-9
2-8	Regulated Plate Voltage Power Supply Circuit. . . . .	2-11
SECTION 3 - INSTALLATION		
3-1	Shipping Container, Cutaway View. . . . .	3-1
3-2	Radiacmeter, Battery Compartment Details . . . . .	3-2
3-3	Initial Test Setup for Radiacmeter . . . . .	3-3
SECTION 4 - OPERATION		
4-1	Attachment of Harness . . . . .	4-2
SECTION 7- CORRECTIVE MAINTENANCE		
7-1	Voltage-Resistance Chart . . . . .	7-4
7-2	Waveform Chart . . . . .	7-5

LIST OF ILLUSTRATIONS - **Cont.**

Figure	Title	Page
7-3	Radiacmeter, Showing Principal Components . . . .	7-10
7-4	Radiacmeter, End View, Showing Calibration Potentiometers . . . . .	7-11
7-5	Calibration Setup and Values . . . . .	7-13
7-6	Radiac Detector <b>DT-106/PDR-27G</b> , Exploded View.	7-14
7-7	Trigger Amplifier <b>Z101</b> , Disassembly . . . . .	7-16
7-8	Trigger Amplifier <b>Z101</b> , Internal Components Layout . . . . .	7-18
7-9	Trigger Amplifier <b>Z101</b> , Preparation for Re-Assembly . . . . .	7-19
7-10	Radiac Set <b>AN/PDR-27G</b> , Schematic Diagram . . . .	7-23
7-11	Radiac Set <b>AN/PDR-27G</b> , Wiring Diagram . . . . .	7-25





SECTION A

INTRODUCTION

A-1. SCOPE

This manual describes Radiac Set AN/PDR -27G and covers its installation, operation, and maintenance. It includes operation under usual conditions, cleaning and inspection of the equipment, and replacement of parts. It also includes the repair parts and special tools list.

A-2 . INDEX OF PUBLICATIONS

~~Refer to the latest issue of DA Pam 310-4 to determine whether there are new editions, changes, or additional publications pertaining to this equipment. Department of the Army Pamphlet No. 310-4 is an index of current technical manuals, technical bulletins, supply manuals, (types 7, 8, and 9), supply bulletins, lubrication orders, and modification work orders available through publications supply channels. The index lists the individual parts (-10, -20, -35P, etc) and the latest changes to and revisions of each equipment publication.~~ See 101

A-3 . FORMS AND RECORDS

~~a. REPORTS OF MAINTENANCE AND UNSATISFACTORY EQUIPMENT. Use equipment forms and records in accordance with instructions in TM 38-750.~~ See ch 1

b. REPORT OF DAMAGED OR IMPROPER SHIPMENT. Fill out and forward DD Form 6 (Report of Damaged or Improper Shipment) as prescribed in AR 700-58 (Army), NAVSANDA Publication 378 (Navy), and AFR 71-4 (Air Force).

c. REPORTING OF EQUIPMENT MANUAL IMPROVEMENTS. The direct reporting of errors, omissions, and recommendations for improving this equipment manual by the individual user is authorized and encouraged. DA Form 2028 will be used for reporting these improvements. This form may be completed by the use of pencil, pen, or typewriter. DA Form 2028 will be completed by the individual using the manual and forwarded direct to Commanding General, U. S. Army Electronics Command, ATTN: AMSEL-MR-(NMP)-MA, Fort Monmouth, New Jersey 07703. See 101

A-4 ADDED

A - 5 ADDED



AN/PDR -27G

SECTION 1

GENERAL DESCRIPTION

1. PURPOSE AND BASIC PRINCIPLES

(See figure 1-1)

Radiac Set AN/PDR-27G is a portable, watertight, battery-operated radiation detector and indicator. It is capable of detecting and measuring beta and gamma radiations together, or gamma radiations alone. Radiacmeter IM-74E/PDR-27C is the main unit of the radiac set; it is equipped with a carrying handle, and also may be carried by an externally connected shoulder harness. Radiac Detector DT -106/PDR-27G is a probe attached externally, by means of a flexible cable, to the radiacmeter. The detector is normally carried in an external well on the radiacmeter and can be easily removed. When measuring gamma radiation, the detector can be used in or out of the well; beta radiations, however, can only be detected when the detector is removed from the well and the beta shield on the end of the probe is moved aside. The radiacmeter also houses an electronic chassis, an indicating meter, and dry batteries. Case CY-963/PDR-27A is a lightweight carrying case which houses the radiacmeter, Radioactive Test Sample MX-1083B/PDR-27, Headset H-43B/U, Harness ST-125A/PDR-27E, spare tubes, spare batteries, two wrenches, and two copies of the instruction book.

Geiger-Muller (G-M) tubes are used in the radiac set to detect gamma and beta radiations. When the G-M tubes are exposed to such radiations, they produce short-duration, d-c voltage pulses at an average repetition rate proportional to the average radiation field intensity in the vicinity of the tubes. These pulses, which are of random duration and random amplitude, are converted to pulses of equal duration and constant amplitude and are used to generate visual and aural indications of the average radiation field strength in the vicinity of the G-M tubes. Visual indication is



provided by a meter reading proportional to the pulse reception rate; aural indication is provided by headphones in which a click is heard for each received pulse.

The range of field intensities capable of being detected by the **radiac** set is relatively broad. Therefore, in order to provide an easily observable meter deflection for any value of field intensity within the operating range of the set, four ranges of sensitivity are provided. Any one range may be selected by means of a **switch** on the radiacmeter panel. The two most sensitive ranges utilize a Navy type **BS-1** G-M tube, which is contained in the probe. This **tube** has a mica end-window covered by a removable metal beta shield. The shield can be moved aside to expose the beta window for beta-plus-gamma radiation readings, and is left in place for gamma radiation reading alone. The two less sensitive ranges utilize a Navy type **BS-2** G-M tube, which is contained inside the **radiacmeter** housing. Only gamma radiation field strengths can be measured on these two less sensitive ranges.

## 2. DESCRIPTION OF UNITS

(See tables 1-1 and 1-2)

Radiac Set AN/ **PDR-27G** consists of the components listed in tables 1-1 and 1-2.

a. CASE **CY-963C/PDR-27A**. (See figure 1-1.)—The carrying case houses all other **radiac** set units. It is completely splashproof and is equipped with carrying handles and hasps. It is fabricated from sheet aluminum and is so constructed that it can be disassembled for decontamination. A spare parts compartment is provided in the case.

b. **RADIACMETER IM-74E/PDR-27C**. — The radiacmeter includes three aluminum castings which comprise the handle, the battery compartment, the waterproof enclosure, and space for the electronic chassis. The handle is cast integrally with a plate which serves as a water-tight cover for the battery compartment. The panel casting provides the means for mounting the electronic chassis, meter, range switch, phone jack, and a compartment for the batteries. The remaining casting completes the waterproof enclosure and provides a well at one end to hold the detector probe, the calibration-port cap, and part of the lead shield assembly

TABLE 1-1. EQUIPMENT SUPPLIED

Quantity per Equipment	Name of Unit	Navy Type Designation	OVER-ALL DIMENSIONS			Volume	Weight
			Height	Width	Length		
1	Case	CY-963C/PDR-27A	9-5/8	11-11/32	16-3/16	1766.	7.5
1	Radiacmeter	IM-74B/PDR-27C	8-1/4	5-7/8	12-5/8	612.	9.38
1	Radiac Detector	DT-106/PDR-27G	1-3/8 dia.		7-13/32	11.5	1.0
1	Headset	H-43 B/U	2-1/8	7	6-1/8	91.3	0.87
1	Harness	ST-125A/PDR-27E	.....	.....	.....	.....	1.12
1	Radioactive Test Sample	MX-1083 B/PDR-27	3/8		5	0.55	0.03
1	Wrench-Special	H-301	3/32 tk.	1-3/4	6	0.97	0.11
1	Wrench-Allen	H-302	5/64 tk.	45/64	61/64	0.60	0.01
2	Instruction Book for Radiac Set AN/PDR-27G	NAVSHIPS-92071	1/4 tk.	5-1/2	7-1/2	20.6	0.5
1	Tube (spare)	BS-101	1/4 dia.		2-3/4	.....	0.04
1	Tube (spare)	BS-1	1-1/4 dia.		7	.....	0.17
1	Tube (spare)	BS-2	3/8 dia.		4	.....	0.02
1	Maintenance Parts Set	Kit	4.0	6-1/2	7.0	182.	1.74
						2674.**	21.49**

Dimensions are in inches; volume, cubic inches; weight, pounds. All weights less batteries.

\*\*Totals do not include the Radiac Detector as it is part of the Radiacmeter.

for Navy type **BS-2** tube (figure 1-4). All joints between castings are made watertight by the use of rubber gaskets, and screws to draw the joints tight,

TABLE 1-2. EQUIPMENT REQUIRED BUT NOT SUPPLIED  
(To be drawn from Supply Department)

Quantity per Equipment	Name of Unit	Standard Navy and (Signal Corps) Stock No.	Required Use
2	Batteries, <b>BA-416/U</b>	<b>N17-B-60513-9657</b> <b>3A275-416</b>	1 operating; 1 spare
2	Batteries, <b>BA-413/U</b>	<b>N17-B-59196-1685</b> <b>3A275-413</b>	1 operating; 1 spare
4	Batteries, <b>BA-401/U</b>	<b>N17-B-58747-3197</b> <b>3A275-401</b>	2 operating; 2 spares

Mounted on the panel are: a four range indicating meter, a range switch, a push button switch assembly for the meter light, and a headset jack. Mounted to the underside of the panel (figures 1-5 and 1-6) are the electronic elements of the equipment including a plug-in unit, **Z-101**, (figure 1-5) containing three subminiature tubes and their associated circuit elements.

The plug-in unit contains the circuit elements shown within the dotted box on figure 7-8. Electrical contact to the plug-in unit is made through 11 base pins, the shell, and one spring-clamp connection. This unit is removable for repair or replacement.

The indicating meter face has a window behind which is placed a meter card with four colored scales (figure 1-3). The meter card is carried on a shaft turned by a sprocket gear. Rotation of the card shaft places the scales, one at a time, within the meter face window; only one scale at a time is visible.

The range switch is a three-wafer, five-section switch with six operating positions selected by switch shaft detents. Mounted on

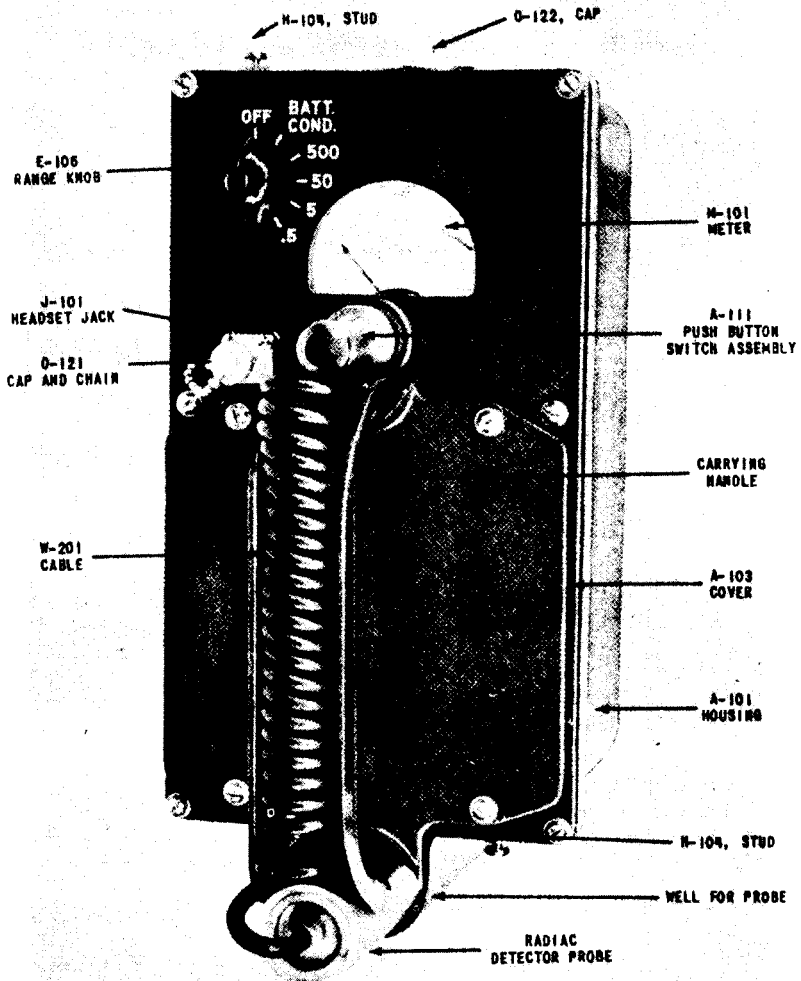

Figure 1-3, Radiacmeter IM-74B/PDR-27C



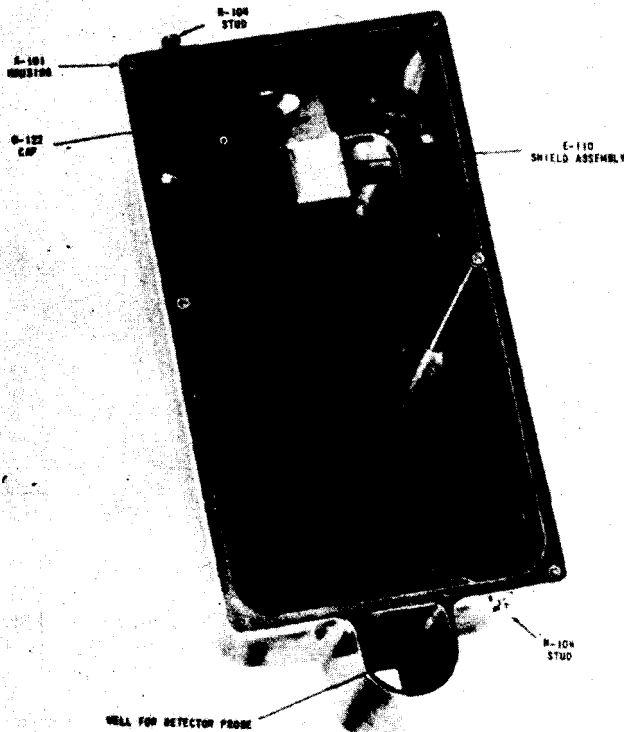

Figure 1-4. **Radiometer Waterproof** Housing

the switch shaft is a sprocket gear 0101 (figure 7-4), connected by a spring-loaded chain with the gear on the card shaft of the meter. As the range switch is turned to the various operating positions, the card shaft positions the corresponding scales of the meter card in the meter face window.

“The battery power is conveyed to the electronic chassis through the wall of the battery compartment by means of a waterproof feed-through, terminal strip. Two single cell filament batteries are mounted in a special molded bakelite holder to facilitate battery **changing** and provide a method for making contact to these batteries. Connection is made to the other batteries by means of two octal plugs, P101.

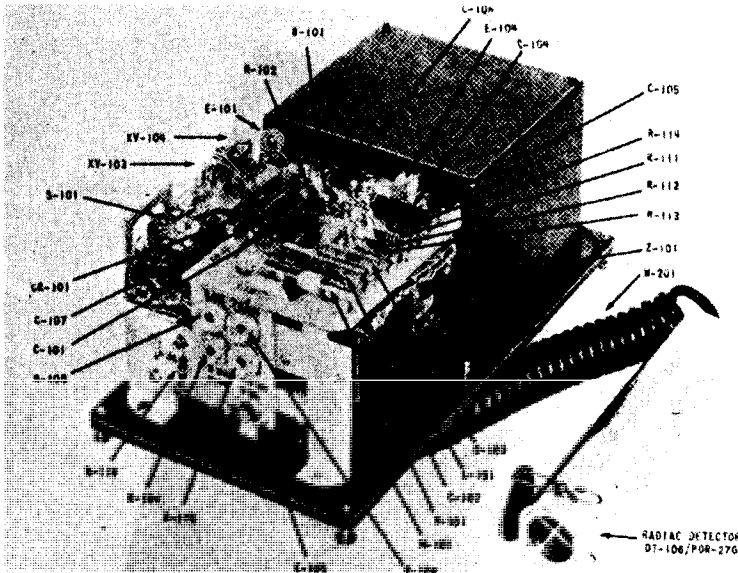
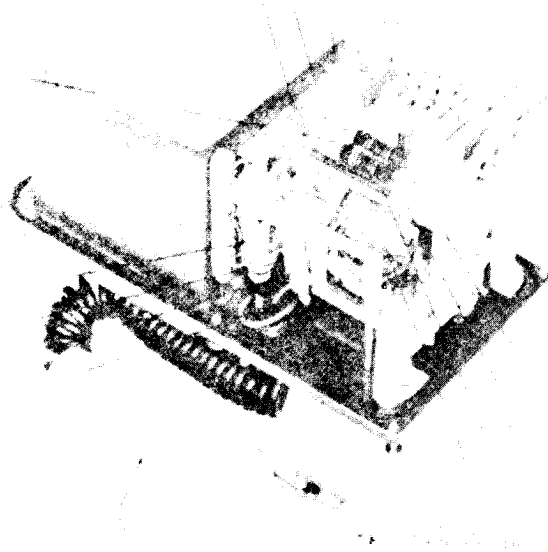

Figure 1-5. Radiacmeter, Right Side and Rear

The carrying handle is constructed to allow space for the radiac detector retractable self coiling cable when the detector is stowed in its well.

c. RADIAC DETECTOR DT-106/PDR-27G (See figure 1-5.) – The radiac detector is a probe consisting of a Navy Type BS- 1 G-M tube contained in a cylindrical metal housing. At one end, the housing is closed by a threaded ring which secures a packing gland for the connection cable; at the other end a threaded ring secures the body of the G- M tube leaving the mica window exposed. The G-M tube is supported by a rubber gasket at the mica window end and further supported inside the housing by a spring mounting cylinder, 0208. Electrical connection to the tube is made by a kinkproof flexible cable which passes through the waterproof packing gland in the threaded plug at the end of the housing. A spring-retained metal shield covers the mica window of the G-M tube. When the shield is over the window, beta radiations are prevented from entering the tube; the shield may be swung aside when beta-plus-gamma radiations are to be detected. A metal guard is secured directly over the window.



*Figure 1-6. Radiacmeter Panel, Left Side and Rear*

## CAUTION

Since the mica window is only 0.0005-inch thick, it is extremely fragile. Do not touch window under any circumstances, as damage to the tube will result. Do not rely on the guard to protect the mica window; the guard openings are large enough so that sharp objects can pass through and pierce the window.

d. HEADSET H-43. (See figure 1-1.)—The headset provides the operator with aural indications of radiation intensity when plugged into the jack on the radiacmeter front panel.

e. HARNESS ST-125A/PDR-27E. (See figure 1-1.)—The shoulder and waist harness, two adjustable straps made of a non-absorbent plastic, is used for carrying the radiacmeter and probe

during operation. Metal clips on the harness fasten to harness buttons secured to the radiacmeter housing (figure 1-3).

f. RADIOACTIVE TEST SAMPLE **MX-1083 B/P DR-27**. (See figure 1-1.)—The radioactive test sample consists of a plastic tube containing approximately 5 microcuries of **radium 226**. The tube is flattened at one end to facilitate handling. The **radium 226** provides a radiation source that permits the operator to ascertain the operating condition of the radiac set when no known radiation field is available.

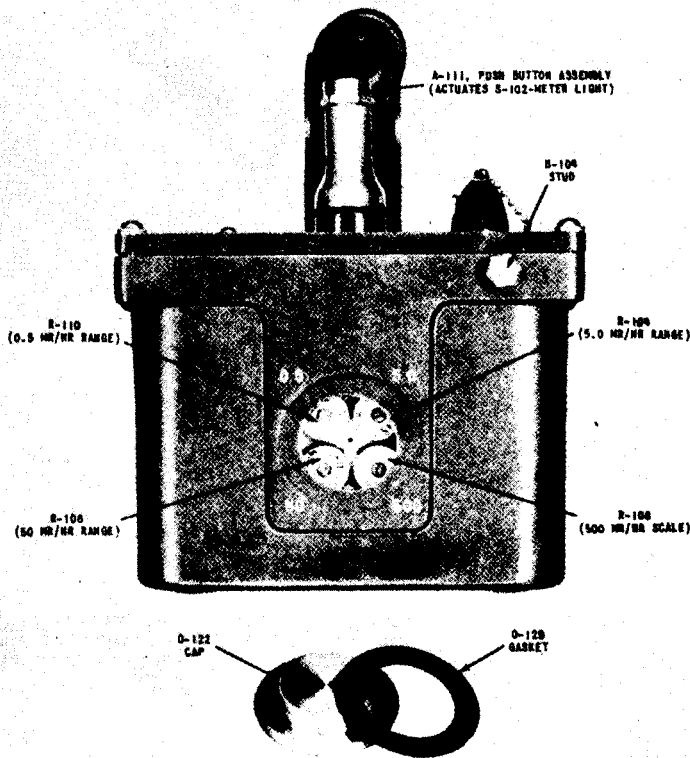

Figure 1-7. **Radiacmeter, Showing Calibration Part and Push Button Assembly**

## WARNING

Because radim 226 is potentially dangerous, serious skin and internal burns may result if the test sample is held close to the skin for prolonged periods. When using the test sample, handle it only long enough to ascertain the operating condition of the radiac set; then replace it in its storage compartment in the carrying case. If the radioactive test sample is broken, notify the officer-in-charge immediately and request disposal instructions.

g. **EQUIPMENT MAINTENANCE PARTS.**- The field maintenance repair parts, consisting of spare batteries, G-M tubes, and a corona-discharge voltage regulator tube are carried in the two small corner compartments of the carrying case (fig. 1-1). In addition, the maintenance Parts Kit (table 8-3) is supplied as a separate package with each Radiac Set (see fig. 3-1).

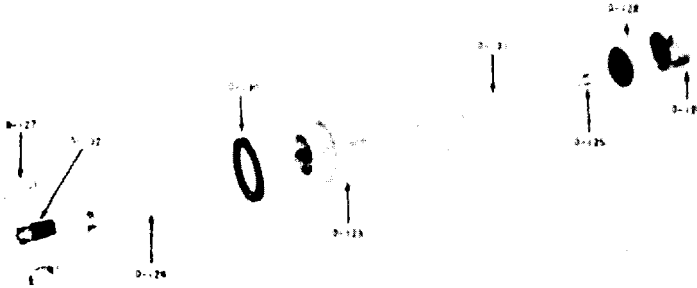

Figure 1-8. Push Button Switch Assembly, Exploded View

### 3. REFERENCE DATA

Reference data applicable to the radiac sets is as follows:

- a. **NOMENCLATURE:** Radiac Set AN/PDR-27G
- b. **CONTRACT NUMBER AND DATE:** NObsr 631-59, December 19, 1952; NObsr 63185, May 14, 1953; NObsr 75734, March 9, 1959; NObsr 75773, May 7, 1959
- c. **CONTRACTOR:** Specialty Electronics Development Corp., Syosset N. Y.

1 **Section**  
Paragraph **3d AN/PDR-27G**

GENERAL  
DESCRIPTION

d. COGNIZANT NAVAL INSPECTOR: Inspector of Naval Material, New York, New York

e. PACKAGES PER SHIPMENT: One

f. CUBICAL CONTENTS: 2.0 cubic feet (including eqpt spares) -

g. WEIGHT:

packed, without batteries -----	38.4 pounds	
unpacked, without batteries -----	20.8 pounds	<b>AN/PDR-27G</b>
unpacked, with batteries -----	23.6 pounds	

Above weights include equipment spares.

h. RANGES: Four sensitivity ranges: 0.5, 5, 50, and 500 mil-liroentgens per hour.

i. TYPE OF DETECTION: Field intensity of gamma radiations alone, or gamma and beta radiations together.

j. TYPE OF DETECTORS: Geiger- Muller tubes, Navy types **BS-1** and **BS-2**.

k. POWER SUPPLY: Dry batteries:

Number Req.	Type	D-C Voltage (volts)	Standard Navy and (Signal Corps) Stock No.
1	<b>BA-416/U</b>	135.0	<b>N17-B-60513-9657</b> (3 <b>A275-416</b> )
1	<b>BA-413/U</b>	22.5	<b>N17-B-59196-1685</b> (3 <b>A275-413</b> )
2	<b>BA-401/U</b>	1.5	<b>N17-B-58747-3197</b> (3 <b>A275-401</b> )

1. HEAT DISSIPATION: Negligible.

TABLE 1-3. SHIPPING DATA

Ship- ping Box No.	CONTENTS Name and Designation	OVER-ALL DIMENSIONS			Volume	Weight
		Height	Width	Length		
1	Radiac Set <b>AN/PDR- 27G</b> (including <b>eqpt</b> spares)	<b>2-1/4</b>	4-3/8	22-1/4	<b>2.0</b>	<b>*38.4</b>

Dimensions are in inches; volume in cubic feet; weight in pounds  
\*Less batteries

4. EQUIPMENT SIMILARITIES. (See table 1-4, pages 1-14 and 1-15.)

TABLE 1-4. EQUIPMENT SIMILARITIES

Equipment Nomenclature	Batteries Required	Trigger Amplifier	Dial Lamp	Calibration Port	High Voltage Power Supply	Energy Independence	Radiac Detector	Carrying Case	Radio Active Test Sample	Wrench
AN/PDR-27	1. National Carbon No. 413  2. National Carbon No. 457  4. Gendry Bat No. RG-4	Ref Symbol Z201 GE. part/dwg no. ML-112J11761  Standard Navy Stock No. N16-R-18301-1008	Turned on by tilting Radiacmeter	None	Uses reactor		DT-53/PDR-27 Cable entrance on side	CY-844/PDR-27	HX-1083/PDR-27 Uses cobalt 60 source	Ref Symbol N111, K112, J86P1
AN/PDR-27A	1. JAN Type BA-416/U  1. JAN Type BA-413/U  2. JAN Type BA-401/U		Turned on by tilting Radiacmeter	None	Uses reactor		DT-53B/PDR-27	CY-963/PDR-27A	HX-1083/PDR-27	
AN/PDR-27B	Same as AN/PDR-27A		Turned on by tilting Radiacmeter	None	Uses reactor					
AN/PDR-27C	Same as AN/PDR-27A	Ref Symbol Z101 Admiral part/dwg GB-162  Standard Navy Stock Number N16-A-35201-1011	Turned on by tilting Radiacmeter	None	Uses reactor	Has lead shields over geiger tubes to assist in energy-independence	DT-53B/PDR-27 Cable entrance on side	CY-963A/PDR-27A	HX-1083B/PDR-27 Uses radium source	Ref Symbol K301 Admiral part/dwg S15A65
AN/PDR-27D	Same as AN/PDR-27A	Ref Symbol A201 Hoffman Radio part/dwg JEA-387  Standard Navy Stock Number N16-A-35201-1012	Turned on by tilting Radiacmeter and by pressing button on handle	Has 4 Calibration access holes	Uses reactor	Has lead shields over geiger tubes to assist in energy-independence	DT-53C/PDR-27 Cable entrance on side	CY-1170/PDR-27D 9-13/16 in. by 18-3/16 in. by 9-7/8 in. weighs 6.44 lb.	HX-1083A/PDR-27 Uses radium source	Ref symbol W401 Hoffman Radio part/dwg JVN-6



GENERAL  
DESCRIPTION AN/PDR-27G

AN/PDR-27E	Same as AN/PDR-27A	Ref Symbol Z101 Admiral part/dwg 9C-329  Standard Navy Stock Number N16-A-35201-1011  This unit interchangeable between 27A, C, and E	Turned on by tilting Radiometer and by using panel push button	Has port	Uses auto-transformer	Has lead shields over geiger tubes to assist in energy-independence	Cable entrance on end, has internal shock mount for tube	CY-9638/PDR-27A Waterproof	MX-10838/PDR-27	Ref Symbol N301 Admiral part/dwg 95154174
AN/PDR-27F	1. JAN Type BA-261/U  2. Gendry Bat No RG-4(B)  3. National Carbon No. 457	Same as AN/PDR-27E	Turned on by tilting Radiometer and by using panel push button	Has port	Uses auto-transformer	Has lead shields over geiger tubes to assist in energy-independence	DT-101/PDR-27F 7-1/8 in lg by 1-3/8 in. dia weighs 1.0 lb	CY-1296/PDR-27F Waterproof, 9-7/8 in. by 10-1/2 in. by 11-1/2 in. weighs 8.13 lb.	MX-10838/PDR-27	Ref symbol N301 Admiral part/dwg 95154174
AN/PDR-27G	Same as AN/PDR-27A	Ref Symbol Z101 Natl Elec Mach Part No. AD-12390. Standard Navy Stock Number N16-A-35201-1028 This is repairable assembly interchangeable between 27A, C, E, and G	Panel push button, no tilt switch	Has port	Uses reactor	Has lead shields over geiger tubes to assist in energy-independence	DT-106/PDR-27G Cable entrance at end, internal shock mount for tube, cap mounts by wire spring	CY-963C/PDR-27A Splashproof 9-5/8 in by 11-11/32 in. by 16-3/16 in. weighs 7.5 lb.	MX-10838/PDR-27	Ref Symbol N301 Nat Elec Mach part/dwg 9A-11801

NOTES:

1. The equipments in the AN/PDR-27 series are basically electrically and mechanically interchangeable; the major difference is in the battery complement.
2. The lead and phosphor bronze shields tend to make the equipment energy independent.

## **SECTION 2 THEORY OF OPERATION**

### **1. RADIOACTIVITY AND ITS DETECTION**

a. **INTRODUCTION.** -With the arrival of atomic energy as an important factor in national defense, naval personnel are called upon to take part in the handling, measurement, and detection of radioactive materials. The following paragraphs will acquaint **user** personnel with the nature of atomic radiations, the **neces-**sity for detecting them, and methods of detection.

b. **ATOMIC RADIATION.** -Many chemical elements, such as radium and uranium, and materials exposed to powerful radioactive disintegrations have the property of expelling minute particles of radiations, which are invisible to the eye. Some of these can penetrate the human body and, if they are of sufficient intensity or duration, can cause serious injury and death. To prevent exposure to damaging concentrations of radioactive materials and to prevent exposure to damaging radiation fields, equipment is provided which detects the presence of these radiations and measures their intensity.

Emissions by radioactive substances are generally composed of **alpha**, beta, and gamma radiations. Certain characteristics of these radiations are important aids in their detection and measurement. The alpha radiation carries a positive charge; it ionizes gases strongly, but it possesses weak penetrating power. The beta radiation carries a negative charge; it does not ionize gases as readily as the alpha radiation, but its penetrating power is much greater. The gamma radiation carries no charge; it ionizes gas molecules by reaction with them, and its **penet** rating power is much stronger than that of the alpha and beta radiations.

c. **DETECTION OF RADIATION.** -The ability of alpha, beta, and gamma radiation to ionize gases is the characteristic most frequently used to detect the presence of radiation. A simple device **for** such detections is a G-M tube (figure 2-1). The tube is filled with a gas mixture at low pressure. A thin wire, the anode of the tube, is oriented axially to a cylinder and insulated from it. A voltage is impressed across the tube so that the wire is positive with respect to the cylinder. The magnitude of the impressed

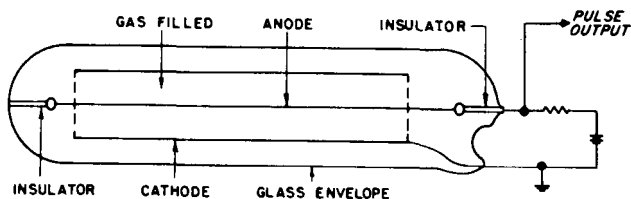
Figure 2-1. Typical **Geiger-Muller** Tube

voltage is just below that necessary to ionize the gas molecules and cause conduction. Therefore, in the dormant condition, no current flows. When radiation is present in the vicinity of the tube, an incoming radiation usually ionizes some molecules of gas within the tube. The ionized gas particles are attracted toward either the cylinder or the wire, depending on their charge. On their way through the gas, these ionized gas particles collide with non-ionized gas molecules and ionize them. As a result of this action, a large portion of the gas becomes ionized, thus **producing** a large current flow. This current flow is quenched quickly, either by a small amount of organic vapor which is included in the gas mixture or by the use of external circuits which reduce the potential between the tube elements after **conduction**. As soon as tube conduction stops, the voltage across the tube is returned to the original pre-ignition value, and the tube awaits the next **ionizing** event. The duration of tube conduction is short compared to the average time between ionizing events and, therefore, the tube output is in the form of a series of pulses. Because of the fluctuating intensity of the ionizing radiations, the **random time interval** between ionizing events, and the chance arrangement of the gas molecules **in the** G-M tube, **the pulses** produced by the tube vary in amplitude (1/2 volt to 50 volts) and duration (50 to 100 microseconds), and occur **at** random time intervals. These pulses are generally used to activate various indicating devices.

d. MEASUREMENT OF RADIATION. —The unit of measurement of radiation is called the 'Roentgen,' or "**r**," and is defined as the amount of gamma radiation that will produce one electrostatic unit of charge in one cubic centimeter of air that is surrounded by an infinite mass of air at standard conditions. Radiation values are usually expressed as milliroentgens per hour, **or mr/hr**. Human tolerance to radiation is usually defined in terms of these units. Radiation intensity (in **mr/hr**) decreases rapidly as the distance from the radioactive object is increased.

2. GENERAL CIRCUIT DESCRIPTION

(See figure 2-2.)

Dry batteries supply **+135-volt** d-c power to the high-voltage power supply and the shunt voltage regulator circuits, 1.5 volt d-c filament power to the high-voltage power supply, the shunt voltage regulator, and the pulse shaper and amplifier circuits, and a 22- **1/2-volt** d-c bias voltage regulator circuit. The batteries are the source of all power for the equipment and, at **25°C.** (77 °F.), can **power** it for **approximately** 40 hours of continuous operation.

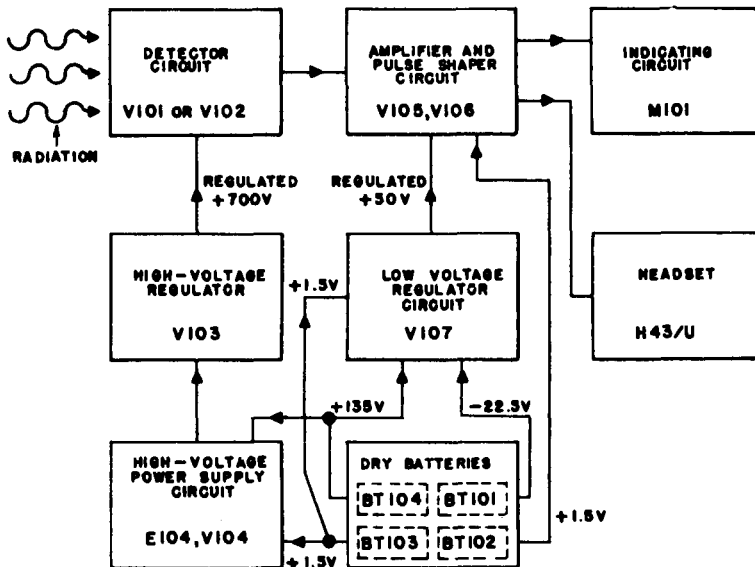

Figure 2-2. Radiac Set AN/PDR-27G, Block Diagram

The high-voltage power supply circuit converts the **+135-volt** d-c power from the batteries into regulated +700- volt d-c power that is fed to the G-M tubes in the detector circuit. The power supply circuit operates on the "fly-back" principle, and utilizes a corona-discharge regulator tube to maintain the output voltage relatively constant.

The G-M tubes generate voltage pulses when exposed to radioactivity. The average repetition rate of these pulses is proportional

to the average radiation field intensity in the vicinity of the tubes, and this rate is used in the radiac set to measure the radiation intensity. The pulses generated in the G-M tubes are of random amplitude and random duration and are fed to the amplifier and pulse shaper circuit. This circuit is a one-shot multivibrator which converts the G-M pulses into pulses of constant area and feeds them to the indicating circuit. The duration of these pulses is different for each sensitivity range.

The indicating circuit converts the pulses fed from the pulse shaper and amplifier circuit to a meter reading proportional to the pulse reception rate. The factor of proportionality depends on the sensitivity range selected by means of the range switch. The meter scales are changed automatically when the sensitivity range of the radiac set is changed by operation of the range switch. Consequently, the meter is always direct-reading.

The shunt voltage regulator circuit maintains the plate voltage of the pulse shaper and amplifier circuit at a relatively constant value as the battery voltage decreases with age.

3. CIRCUIT ANALYSIS

a. DETECTOR CIRCUIT. (See figure 2-3. )—The detector circuit consists of G-M tubes **V101** and **V102**, anode load resistor **R101**, coupling capacitors C1 13, and section **S101A** of range switch **S101**.

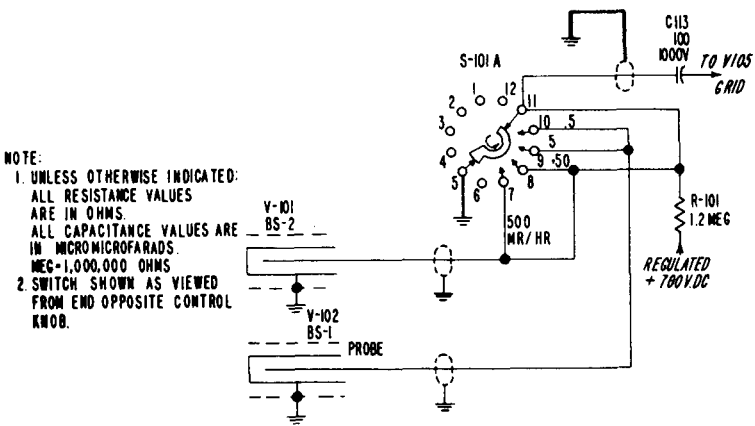

Figure 2-3. **Detector** Circuit

The two G-M tubes are used as radiation detectors. Tube **V102**, a Navy type **BS-1** tube, is the more sensitive of the two and is used in the probe. When **S101A** is in any of the four range positions **V101** is connected to the radiacmeter. When **S101A** is in either the 0.5 or 5.0 position **V102** is also connected to the radiacmeter.

When **S101A** is turned to one of the range positions, regulated +700-volt d-c power is applied through anode load resistor **R101** to the anode of the selected G-M tube. When the G-M tube conducts under the influence of an ionizing event, a voltage pulse is developed across resistor **R101**. This pulse is capacitively coupled through **C113** to the input grid of **V105** in the pulse shaper and amplifier circuit. The output of the G-M tube is a series of negative-going pulses, one for each ionizing event that occurs within the tube. The approximate average duration of these pulses is 80 microseconds, and their average amplitude is approximately 5 volts, although pulse amplitudes of 50 volts occur occasionally.

b. PULSE SHAPER AND AMPLIFIER CIRCUIT. (See figure 2-4.)—The pulse shaper and amplifier circuit consists of tubes **V105** and **V106**, section **S101B** (front) of range switch **S101**, and associated resistors and capacitors. This circuit converts the random-amplitude, random-duration pulses from the detector circuit into pulses of constant amplitude and constant duration and feeds them to the indicating circuit. The amplitude and duration of the output pulses are seriously affected by changes in the plate supply voltage of **V105** and **V106**. To eliminate this effect, the plate supply voltage for both tubes is regulated.

Tubes **V105** and **V106** (connected as triodes) comprise a single-shot multivibrator. In the dormant state—that is, when no pulses are received from the detector circuit—**V105** is conducting and **V106** is cut off. Resistor **R119** is the plate load for **V105** which is made to operate as a triode by connection of its screen grid to its plate. Resistors **R117** and **R118** comprise a voltage divider; these resistors, in conjunction with common cathode resistor **R120**, establish the steady-state grid bias for **V105**. As a result of this bias, **V105** conducts in the dormant state. Tube **V106** is also connected as a triode amplifier. The control grid of **V106** is connected, via one of the resistance paths, through **S101 B** (front) to ground. The cathode of **V106** is connected to the cathode of **V105** and is, therefore, held positive by the steady-state current through **V105**; thus, **V106** is held in the cut-off condition during the dormant state.

The negative going pulses from the detector circuit are applied to the control grid of **V105**. These pulses drive the grid of **V105**

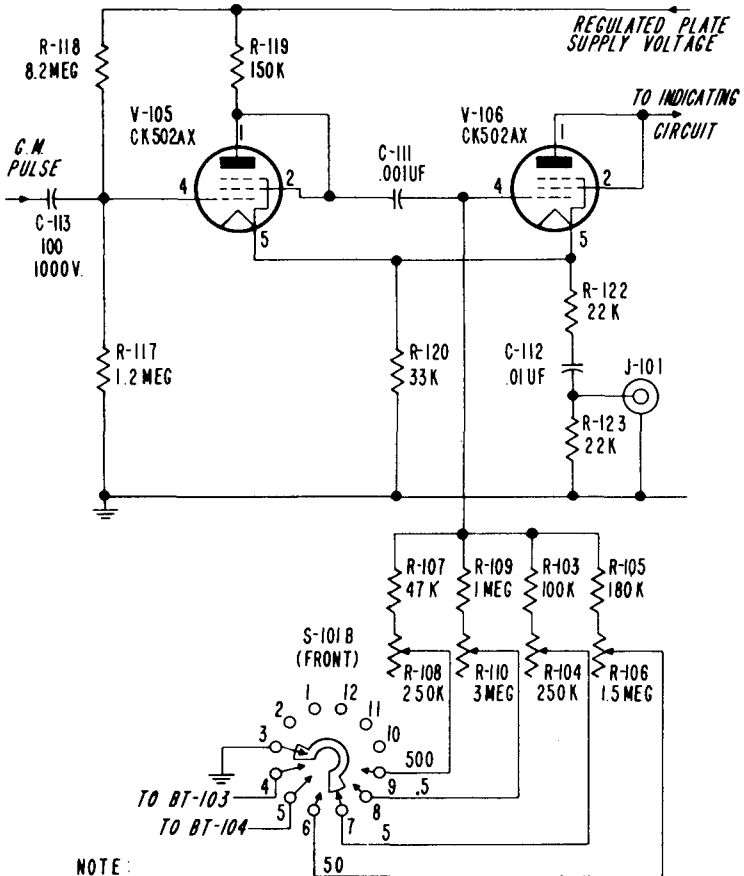

NOTE:  
 1. UNLESS OTHERWISE INDICATED:  
 ALL RESISTANCE VALUES ARE IN OHMS  
 ALL CAPACITANCE VALUES ARE IN MICROMICROFARADS  
 K=1,000 OHMS  
 MEG=1,000,000 OHMS  
 UF= MICROFARADS  
 2. SWITCH SECTION, AS VIEWED, ROTATES COUNTERCLOCKWISE.

Figure 2-4. Puke Shaper and Amplifier Circuit

more negative. The resulting rise in the plate potential of V105 is coupled through capacitor C111 to the control grid of V106, causing V106 to conduct heavily and charging C111. Plate voltage for

**V106** is applied through components of the indicating circuit. As long as **V106** conducts, **V105** is held at cut-off by the rise in cathode potential caused by the plate current flow of **V106** through common cathode resistor **R120**. Capacitor **C11** now discharges to ground through the selected resistance path and **S101B** (front). Tube **V106** conducts until the discharge of **Cl 11** has lowered its control grid voltage to cut-off. The length of time that **V106** conducts is determined by the R-C time constant of **Cl 11** and the selected resistance path to ground. Four separate resistance paths to ground from the **V106** grid are provided by **R103** and **R104**, **R105**, and **R106**, **R107**, and **R108**, and **R109** and **R110**. Potentiometers **R104**, **R106**, **R108**, and **R110** are provided for calibration of the equipment on the four ranges.

When **V106** reverts to cut-off, the corresponding drop in its cathode potential, directly coupled of **V105**, permits **V105** to conduct its steady-state current again. Since the average time between successive pulses from the detector circuit is considerably longer than the duration of the conduction of **V106**, the entire circuit reverts to its steady-state condition after each input pulse.

The output of **V106**, a series of current pulses, is fed to the indicating circuit. The duration of the **V106** output pulses is determined primarily by the constant of the selected coupling circuit, and is thus constant for any particular range; each range has a different time constant because the grid to ground resistance of **V106** is changed by **S101B** whenever ranges are changed. Consequently, the duration of the output pulse changes when ranges are changed.

The pulsed fluctuations of the **V105** and **V106** cathodes are applied to a voltage divider circuit consisting of **R122**, **Cl 12**, and **RI 23**. The a-c component of the cathode fluctuations generates a voltage across **R123**, and this voltage is applied to jack **J101**. A headset may be connected to **J101** for aural monitoring of the radiation intensity.

c. INDICATING CIRCUIT. (See figure 2-5.)—The indicating circuit consists of capacitor **C103**, resistor **R121**, and meter **M101**. Capacitor **C103** is connected in parallel with **M101**. The complete circuit is connected between the plate of **V106**, in the pulse shaper and amplifier circuit, and the **V106** plate supply. When **V106** conducts, the current pulse charges **C103** and causes a meter deflection. During the interpulse interval, **V106** is cut off, causing **C103** to discharge through **M101** and thus to maintain the deflection nearly constant, so long as the radiation strength is unchanged.



The function of the indicating circuit is to convert the output pulses of **V106** into a relatively steady meter deflection proportional to the radiation intensity. The pulsed output of **V106** is stored in **C103** which acts with **R121** to form a fairly steady current in the meter. Meter inertia aids in maintaining the deflections nearly constant for a given radiation strength. The average current through **M101** depends on the following factors:

1. The number of pulses per second received from **V106**.
2. The amplitude and duration of each pulse.

Since the number of pulses per second is proportional to the radiation intensity, the average meter current will be proportional to the radiation intensity as long as the amplitude and duration of each pulse remain the same. i. e., at any one position of range switch **S101**. When ranges are changed, the amplitude and duration of the pulses from **V106** change; consequently, the meter current per puke per second also changes.

The meter deflection is proportional to the average meter current; this current is proportional to the number of pulses per second, and the number of pulses per second is, in turn, proportional to the radiation intensity for a given type of radiation. Consequently, the meter scale can be calibrated to indicate mr/hr (milli-roentgens per hour) directly.

d. RANGE SWITCH CIRCUITS. -The functions performed by each of the five range switch **S101** sections are shown in figure 2-6.

e. FILAMENT POWER SUPPLY CIRCUIT. -Battery **BT102** provides 1.5 volts for the filaments of **V105** and **V106**, and is connected to these filaments in all positions, except OFF, of range switch **S101B** (rear). This battery "floats" with respect to the chassis, thus permitting a potential difference to exist between the filaments and chassis.

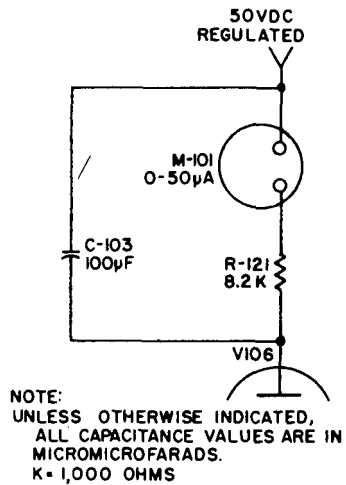

Figure 2-5. Indicating Circuit

Switch Position	Section S101A front	Section S101B rear	Section S101B front	Section S101C front	Section S101C rear
OFF	Grounds output side of high voltage power supply filter through R101.	Disconnects BT102 from V105 and V106 filaments.	Grounds V106 control grid circuit.	Applies direct short circuit to M101 terminals.	Grounds negative of M101.
BATT COND	None.	Connects BT102 to V105 and V106 filaments.	Grounds negative of BT103; grounds V106 control grid circuit.	Connects positive of BT103 to positive of M101.	Connects negative of BT103, through R111 to negative of M101.
500	Connects cap of Z101 and high voltage power supply output to V101.	Connects BT102 to V105 and V106 filaments.	Grounds negative of BT103, BT104; grounds V106 control grid through R107 and R108.	Connects positive of M101 to regulated voltage output of voltage regulator V107.	Connects negative of M101 to output of pulse shaper V106 through R121.
50	Same as 500 position.	Same as 500 position.	Grounds negative of BT103 and BT104; grounds V106 control grid through R105 and R106.	Same as 500 position.	Same as 500 position.
5	Connects cap of Z101 and high voltage power supply output to V102 and V101.	Same as 500 position.	Grounds negative of BT103 and BT104; grounds V106 control grid through R103 and R104.	Same as 500 position.	Same as 500 position.
.5	Same as 5 position.	Same as 500 position.	Grounds negative of BT103 and BT104; grounds V106 control grid through R109 and R110.	Same as 500 position.	Same as 500 position.

Figure 2-6. Circuit Connections for Different Positions of S101

Battery **BT103** provides 1.5 volts for the filaments of **V104** and **V107**; this battery is connected to these filaments in all positions, except OFF, of **S101B** (front). In the BATT COND position of **S101C** (rear), **M101** and resistor **R111** are connected in series across the battery to provide an indication of battery condition. A black line, marked BATT, on the meter face indicates the minimum operating voltage of the battery.

f. HIGH-VOLTAGE POWER SUPPLY CIRCUIT. (See figure 2-7.)—The high-voltage power supply circuit consists of a relaxation oscillator circuit, a power amplifier circuit, a rectifying and filtering circuit, and a regulating circuit.

(1) RELAXATION OSCILLATOR CIRCUIT. (See figure 2-7.)—In this circuit, +135-volt d-c power from **BT104** is applied through resistor **R112** to capacitor **C104**. Tube **E104**, a cold-cathode glow-discharge tube, is connected across **C104**. Capacitor **C104** charges slowly until it reaches a value equal to the striking voltage, approximately 90 volts, of **E104**. As soon as 90 volts is reached, **E104** conducts heavily and discharges **C104** almost instantaneously. Capacitor **C104** then starts to charge again, and the cycle is repeated as long as the equipment is operating. The sawtooth voltage across **C104** is coupled through capacitor **C105** to the control grid of **V104** in the high voltage amplifier circuit.

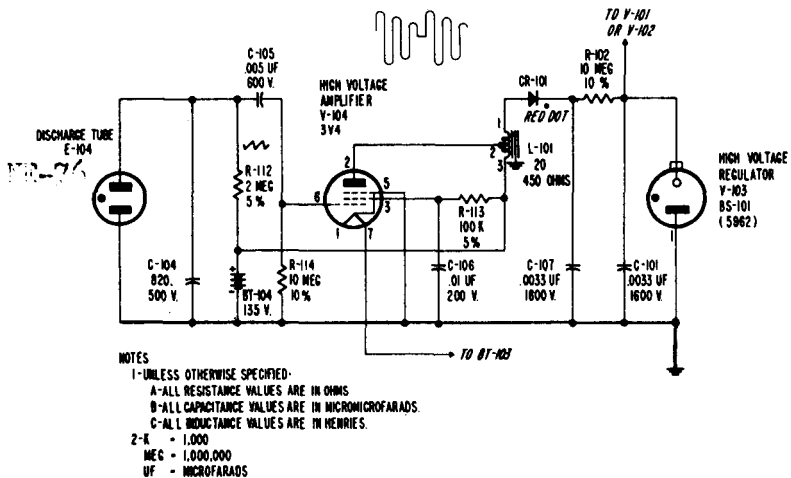

Figure 2-7. High Voltage. Power Supply Circuit

(2) HIGH VOLTAGE AMPLIFIER CIRCUIT. (See figure 2-7.)  
—In the high voltage amplifier circuit, **+135-volt** d-c power is fed to the high voltage amplifier tube **V104** through the center tap of reactor **L101**. Resistor **RI 13** and capacitor **C106** provide the screen grid bias of **V104**. The positive-going part of the sawtooth voltage applied to the grid of **V104** causes the **V104** plate current to buildup gradually, then the negative-going portion of the sawtooth voltage drives the grid rapidly beyond cut -off. When the plate current of **V104** increases during the slow rise of its grid voltage, energy is stored in the magnetic field of **L101**. As soon as the plate current of **V104** is cut off by the sharp fall of grid voltage, the collapse of the magnetic field of **L101** causes a damped oscillating voltage to exist on the **V104** plate. The amplitude of the oscillations is large because of the large inductance of **L101** and the sudden current change. This voltage is stepped up by auto-transformer action and applied to the rectifying and filtering circuit.

(3) Rectifying AND FILTERING CIRCUIT. (See figure 2-7. )—In the rectifying and filtering circuit, the oscillations of **L101** are rectified. Half-wave rectification is provided by selenium rectifier **CR101**; the rectified voltage is filtered in a network consisting of resistor **R102** and capacitors **C107** and **C101**. The rectified oscillations provide approximately **900-volt** d-c power at the junction of **R102** and **C101**. This output is applied to the regulating circuit.

(4) REGULATING CIRCUIT. (See figure 2-7.)—The regulating circuit consists of resistor **R102** in series with corona-discharge tube **V103**. Tube **V103** functions in a manner similar to the standard gaseous discharge voltage regulator tubes, except that it regulates at 700 volts. Resistor **R102** limits the current through **V103**. Capacitor **C101**, in parallel with **V103**, bypasses noise and stray voltages induced in the wires. Regulated **700-volt** d-c power is fed from the junction of **R102** and **V103**, through **R101** in the detector circuit, to either **V101** or **V102**. Note that **R102** serves a dual function. It is common to the filter circuit and to the regulating-circuit.

g. REGULATED PLATE VOLTAGE POWER SUPPLY CIRCUIT. (See figure 2-8. ) —The regulated plate voltage power supply circuit consists of battery **BT104**, a shunt voltage regulator circuit, and capacitor **C102**. Battery power is applied through resistor **R127** to a voltage divider consisting of resistors **R124** and **R125**. The control grid of shunt voltage regulator **V107** is held at a potential 22- 1/2 volts below the potential existing at the junction of

**R124** and **R125** by means of battery **BT101**. Tube **V107** is connected as a triode. The voltage existing on the plate of **V107** depends on the potential drop caused by the **V107** plate current through **R127** and **R126**. The plate current of **V107** is, in turn, governed by the potential on the control grid.

As the batteries age, their output voltage decreases, causing a corresponding decrease in the potential applied to the **V107** grid. The resulting decrease in **V107** plate current causes a corresponding decrease in the potential drop across **R127** and **R125**. Thus, as the battery voltage decreases, the potential drop across **R127** and **R125** decreases; this action tends to maintain the voltage at the plate of **V107** at a constant value throughout the usable life of the batteries.

The load of this power supply consists of a series of short-duration, high-current pulses, separated by relatively long periods of zero current. The shunt voltage regulator and batteries alone are not capable of supplying the pulse current requirements without serious decreases in voltage. However, the supply voltage must remain constant during the pulse. Therefore, **C102**, connected across **V107**, is used to maintain the voltage at constant level. During each current pulse, **C102** acts as a low-impedance source of power; during the interpulse interval, the charge on **C102** is replenished. Capacitor **C102** is sufficiently large to prevent a substantial decrease in voltage during the load-current pulse.

h. **METER ILLUMINATION CIRCUIT.** (See figure 7-10.)—The meter illumination circuit consists of a push button switch **S102**, glow discharge lamp **E105**, and resistor **R116**. Resistor **R116** limits the current through **E105** to its operating value. Pushing the rubber capped plunger operates switch **S102** and closes the meter illuminating circuit if the range switch knob is in any one of the four Operating ranges. The light is intended for use only when readings must be made in dimly lighted areas.

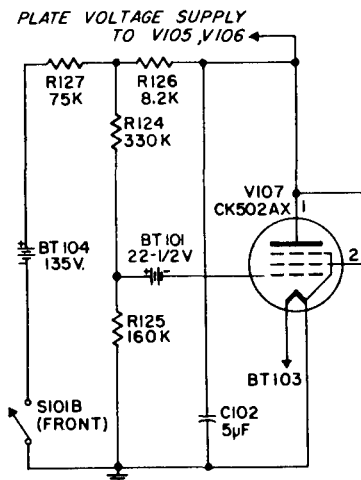

NOTE:  
UNLESS OTHERWISE INDICATED:  
ALL RESISTANCE VALUES ARE IN OHMS.  
ALL CAPACITANCE VALUES ARE IN  
MICROMICROFARADS.  
K = 1,000 OHMS

Figure 2-8. Regulated Plate Voltage  
Power Supply Circuit

## SECTION 3 INSTALLATION

### 1. UNPACKING

(See figure 3-1)

**The** radiac set is shipped in a two compartment corrugated shipping case. One compartment contains the radiac set with spare tubes and tools. The other compartment contains a box of replacement parts for maintaining the set. No batteries are included.

1. Be sure the case is right side up. Cut through the tape on the top cover and open the shipping case.

2. The shipping case holds two unit containers, one for the radiac set, one for spare parts. The larger of these is the radiac set, so labeled.

3. The unit container for the radiac set consists of an outer carton, inside of which is a sealed barrier bag, and inside of this bag is an inner unit carton.

4. The spare parts container is a corrugated carton which is packed in the same shipping container and marked Maintenance Parts Kit.

### 2. INSTALLATION

Batteries must be installed in the radiac set before the set can be operated. In addition, one set of spare batteries should be placed in the carrying case; these batteries are to be used as field spares. When installing batteries, perform the following steps:

- Step 1. Obtain batteries listed in Table 1-2 from Supply Department.
- Step 2. Place spare batteries in the spare battery compartment of the carrying case.
- Step 3. Remove the **radiacmeter from** the carrying case. Remove the four screws securing the handle and cover of the battery compartment. Remove the cover.

3-0

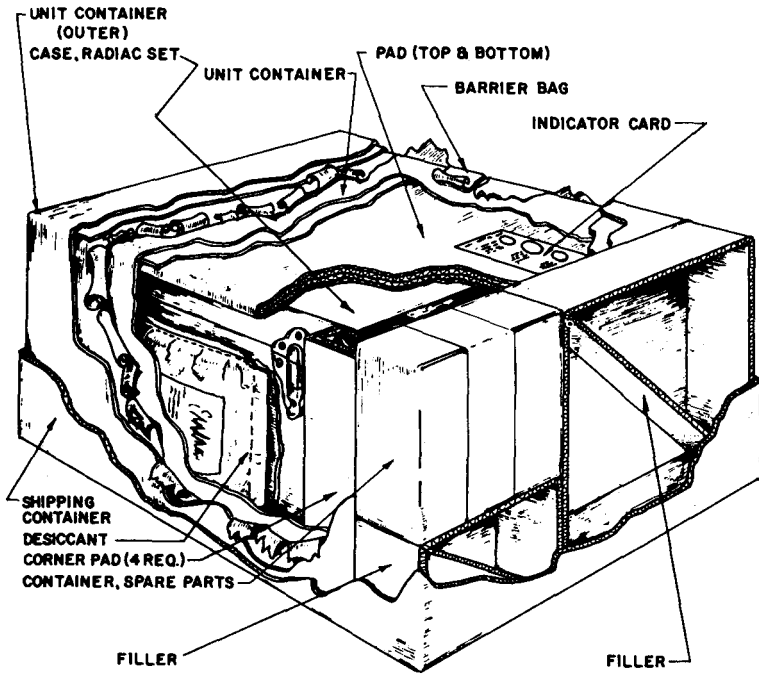

Figure 3-1. Shipping Container, Cutaway View

- Step 4. Place the batteries in the battery compartment as shown on diagram inside battery compartment and in figure 3-2.
- Step 5. Replace the cover.
- Step 6. Replace the screws securing the cover and tighten. Screws must be tightened equally on all sides, or rubber gasket may be damaged.

### CAUTION

Do not use excessive force in tightening screws. Breakage may result.

### 3. INITIAL TESTING

(See figure 3-3.)

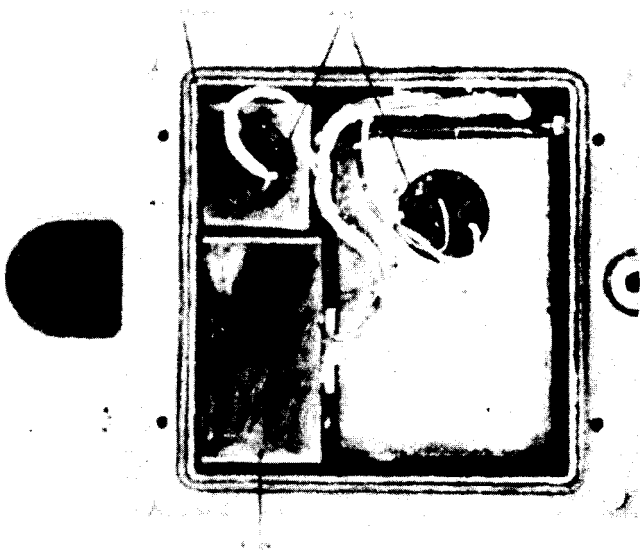

Figure 3-2. Radiacmeter, Battery Compartment Details

Test the radiac set before placing the unit in operation by performing the following steps:

### WARNING

Steps 4 through 9, below, involve handling of the radioactive test sample containing radium 226. Exercise the utmost caution in handling the test sample. Obey all safety regulations. Perform steps 4 through 9 as rapidly as possible to avoid prolonged exposure to the radiation.

- Step 1. Remove the radiacmeter from the carrying case.
- Step 2. Turn the range switch to BATT COND. The indicating meter pointer should now rest to the right of the black line marked BATT.



Step 3. Turn the range switch to 500. The meter reading should be zero.

Step 4. Remove the radioactive test sample from the carrying case.

**NOTE**

A dimple is provided on the bottom surface of the radiacmeter housing. When the active end of the radioactive test sample is placed in this dimple, maximum meter deflection is obtained.

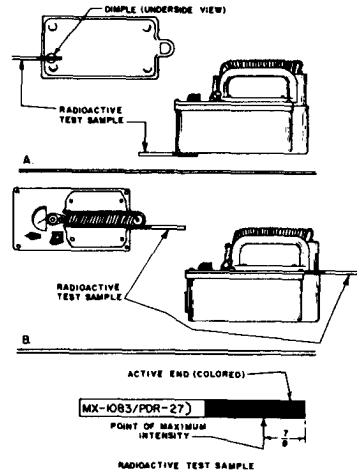

Step 5. Place the test sample in the dimple under the radiacmeter housing as shown in figure 3-3. The meter reading should be 10 to 30 mr/hr.

Step 6. Turn the range switch to 50. Place the test sample in the dimple under the radiacmeter housing as shown in figure 3-3A. The meter reading should be 5 to 15 mr/hr.

Step 7. Turn the range switch to 5. Hold the active end of the test sample near the radiacmeter probe as shown in figure 3-3B. The meter reading should be 1 to 3 mr/hr.

Step 8. Turn the range switch to .5. Hold the test sample near the radiacmeter probe, as shown in figure 3-3B, with the active end of the sample pointing away from the probe. The meter reading should be 0.10 to 0.30 mr/hr.

Step 9. Replace the test sample in the carrying case.

Step 10. Turn the range switch to OFF.

Figure 3-3. Initial **Test Setup** for **Radiacmeter**

**3 Section**  
**Paragraph 3 AN/PDR-27G**

INSTALLATION

When the meter readings specified in steps **2, 3, 5, 6, 7,** and **8** are obtained, the **radiac** set is in proper operating condition. If any of the meter readings are incorrect, trouble shoot the **radiac** set as instructed in Section **7**.

**NOTE**

To obtain more exact readings of the meter refer to the calibration procedure **in Section 7-6a** and Section **7-6b**.

## SECTION 4 OPERATION

### 1. GENERAL

This section contains the procedures for starting the **radiac** set, for operating it to detect and measure atomic radiation and to locate radioactive objects or areas, and for stopping the set. The **radiac** set indicates the presence of radiation by clicks in the headset and by the reading shown on the radiacmeter panel meter. The meter reading and the frequency of the clicks are proportional to the radiation intensity.

### 2. STARTING THE EQUIPMENT

- Step 1. Remove the radiacmeter harness and headset from the carrying case.
- Step 2. Hold the shoulder strap of the harness (long strap) at approximately the center point with the shoulder strap held above the waist strap and with the strap ends at the hooks facing away from the operator.
- Step 3. Place one arm through the opening and slip the long shoulder strap over the shoulder. Do not place the head through this opening.
- Step 4. Hold the radiacmeter against the body in the position it will be carried. (See figure 4-1. ) The unit may be placed on the edge of a bench to facilitate attachment of the strap hooks.
- Step 5. Place **the shoulder** strap hook, positioned at the front of the body, over the adjacent stud on the side of the radiacmeter.
- Step 6. Reach in back of the body for the other strap hook and slip it over the stud positioned on the other side of the radiacmeter. The radiacmeter may now be shifted to a comfortable position.
- Step 7. The shoulder strap and waist strap are adjustable for proper length to fit the individual carrying the unit. Lengthen or shorten the straps as required.

4 Section  
Paragraph 2 AN/PDR-27G

OPERATION

Step 8. When aural indications are desired, put on the headset and connect its plug to the jack on the radiacmeter panel.

see ch 1 ADD  
see ch 1 8.1 ADD



Figure 4-1. Attachment of Harness

Step 9. Observe the meter indication. If the pointer rests at the left of the center line, marked BATT, on the meter face, replace all batteries in the radiacmeter as instructed in Section 3, par. 2.

Step 10. Turn the range switch to 500.

### 3. RADIATION DETECTION AND MEASUREMENT

Step 1. Listen for clicks in the headset or observe the meter reading while approaching the radioactive object or area.

#### NOTE

When the radiacmeter is used in a dimly lighted area, the meter dial may be illuminated by pressing the switch button. This button is on top of the switch post located between the carrying handle and the meter. The light does not operate except when the range switch is on one of the selected scale ranges.

Step 2. Turn the range switch to a lower (more sensitive) range whenever the meter reading is less than 5 divisions; turn

it to a higher (less sensitive) range if the meter pointer approaches the high end of the scale.

- Step 3. When using only the headset for detection, keep the range switch at 500. When the radiation intensity is relatively weak, turn the switch to 5.
- Step 4. When it is desired to locate a radioactive object or the center of a radioactive area, move the radiacmeter in the direction that produces an increase in the meter reading or in the frequency of the clicks in the headset. Continue moving in this direction until the point of maximum radiation intensity is found.
- Step 5. To facilitate detection and measurement when the object or area to be investigated is relatively inaccessible, lift the radiac detector out of the well on the radiacmeter. Set the range switch at .5 or 5 whenever the **radiac** detector is used in this manner.
- Step 6. When the radiation from an object or area is extremely weak, bring the radiation detector within a few inches of the object in order to obtain an indication of the radiacmeter, because the radiation intensity decreases rapidly with distance.
- Step 7. To check the combined beta and gamma radiation of an object, turn the range switch to .5 or 5, lift the radiac detector out of the well on the radiacmeter, and move aside the beta shield at the end of the radiac detector probe. Point the exposed end of probe at the object to be investigated and move it, slowly, until a readable meter indication is obtained.
- Step 8. If the equipment has been used, continuously for more than 20 hours, check the condition of the batteries in the radiac meter by turning the range switch to BATT **COND**. When the meter pointer rests to the left of the center line, marked BATT, on the meter face, replace all batteries as instructed in Section 3, par. 2.

#### 4. STOPPING THE EQUIPMENT

- Step 1. Turn the range **switch** to OFF.
- Step 2. Disconnect the headset plug from the jack on the radiacmeter panel, and remove the headset (if used).

## 4 Section

### Paragraph 4

### AN/PDR-27G

## OPERATION

- Step 3. Stow the **radiac** detector in the well on the **radiacmeter**. If the detector does not slide easily into the well, or if the cable does not coil tightly over the handle, rotate the probe so as to add or subtract turns to the coiled cable until the detector can be readily stowed.
- Step 4. Unhook the **radiacmeter** from the shoulder harness, and remove the harness.
- Step 5. Stow the radiacmeter, harness, and headset in the case.

### 5, SUMMARY OF OPERATION

- Step 1. Remove the equipment from the case, attach the shoulder harness, and plug in the headset.
- Step 2. Check the battery condition by turning the range switch to BATT **COND**. The meter pointer should rest at the right of the center line, marked BATT, on the meter face.
- Step 3. Set the range switch at either 500, 50, 5 or .5, depending on the intensity of the radiation.
- Step 4. Check for the presence and the intensity of radiation by observing the meter reading or the frequency of the clicks in the headset.
- Step 5. When necessary, illuminate the meter face by using the push button switch located on the meter panel just below the meter.
- Step 6. When the combined beta and gamma radiation from an object is to be measured, turn the range switch to .5 or 5, remove the **radiac** detector from the well of the radiacmeter, move aside the beta shield on the probe, point the probe at the object to be investigated, and move the probe close enough to the object to obtain a meter indication.
- Step 7. Stop the equipment by turning the range selector switch to OFF. Remove the harness and headset from the radiacmeter, replace the radiac detector in the well of the radiacmeter, and stow all items in the carrying case.

### CAUTION

~~The batteries should be removed from the radiacmeter and from the case if the equipment is not to be used for a prolonged period (approximately three months or more).~~

See ch 1 Substitute

## SECTION 5 OPERATORS MAINTENANCE

### 1. BATTERY CHECK

Check the condition of the batteries by turning range switch **S101** to BATT COND position. The pointer on meter **M101** should read to the right of the thin black line marked BATT in the center of the meter scale. If the meter reading is low, the batteries are weak, and should be replaced as instructed in Section 3, par. **2**.

Note that the above check tests the condition of battery **BT103** only. However, since the batteries are rated for approximately equal life, all batteries will normally be in the same condition unless the other batteries were recently replaced. Therefore, whenever battery replacement is required, replace the complete set of batteries.

### 2. EMERGENCY MAINTENANCE

#### NOTICE TO OPERATORS

DO not perform the following emergency maintenance procedure without proper authorization.

Replacement of tubes in the radiacmeter or **radiac** detector is the only emergency maintenance possible during operation of the **radiac** set. Replace tubes as instructed in Section 7. Exact procedures must be followed for **G-M** tubes to avoid damage. Read special instructions under 7-7.

## SECTION 6

### PREVENTIVE MAINTENANCE

#### 1. SCOPE OF OPERATOR ' S PREVENTIVE MAINTENANCE

The preventive maintenance duties assigned to the operator of Radiac Set AN/PDR-27G are listed below. The only tool required other than the tools issued with the set is a brush for cleaning.

- a. Operator's daily preventive maintenance checks and services.
- b. Operator's weekly preventive maintenance checks and services.
- c. Cleaning (para 5).

#### 2. MATERIALS REQUIRED

- a. Cleaning compound.
- b. Fine sandpaper.
- c. Textile cloth.

#### 3. OPERATOR'S PREVENTIVE MAINTENANCE

Preventive maintenance is the systematic care, servicing, end inspection of equipment to prevent the occurrence of trouble, to reduce downtime, and to insure that the equipment is serviceable.

a. **SYSTEMATIC CARE.** The procedures in tables 6-1 and 6-2 and paragraph 5 cover routine systematic care and cleaning essential to proper upkeep and operation of the equipment.

b. **PREVENTIVE MAINTENANCE CHECKS AND SERVICES.** The preventive maintenance checks and services tables outline functions to be performed at specific intervals. These checks and services are to maintain equipment in a serviceable condition; that is, in good general (physical) condition and in good operating condition. To assist operators in maintaining serviceability, the tables indicate the items to be inspected; the References column lists the sections and paragraphs that contain detailed repair or replacement procedures. If a defect cannot be corrected by the operator, a higher level of maintenance is required. Records and reports of these checks and services must be made in accordance with the requirements set forth in TM 38-750.

#### ~~CAUTION~~

*check 1* ~~Remove batteries from equipment that is to be removed from service for 2 weeks or longer. Instructions for removing the battery compartment cover are contained in section 3, paragraph 2.~~ *del*



#### 4. OPERATOR ' S **PREVENTIVE MAINTENANCE** CHECKS AND SERVICES PERIODS

a. Preventive **maint enance** checks and services of **Radiac Set AN/PDR -27G** are required dally and weekly. Table **6-1** specifies checks and services that must be **accomplished** daily. In addition to the routine daily checks and services, check and service the **equipment** immediately before going on a **mission** and as soon as possible after **completion** of the mission.

b. Table **6-2** specifies additional checks and services that must be performed once each week.

TABLE 6-1. OPERATOR'S DAILY PREVENTIVE MAINTENANCE CHECKS AND SERVICES

Sequence No.	Item to be inspected	Procedure	References
1	Exterior surfaces	Inspect exterior surfaces (fig. 1-3) for dust, dirt, and grease.	Para 5.
2	Operation	During normal operation:  a. Check range switch for binding or looseness.  b. Check pushbutton switch All1 for binding.  c. Check meter M101 for sticking pointer.  d. Check for meter M101 indication to right of BATT while range switch is in BATT COND. position.	a. None.  b. None.  c. None.  d. Sect. 3, para 2.

TABLE 6-2. OPERATOR'S WEEKLY PREVENTIVE MAINTENANCE CHECKS AND SERVICES

Sequence No.	Item to be inspected	Procedure	References
1	Calibration port cap 0122 (fig. 1-7)	Clean dirt from calibration port cap 0122; tighten cap with wrench H301 (fig. 1-1).	
2	Batteries and battery compartment (fig. 3-2)	Inspect batteries for leakage; inspect battery compartment for corrosion. <i>As per Section - 3-2-1</i>	Sect. 3, para 2.
3	Meter M101	^ Inspect meter M101 for cracked or broken glass.	

## 5. CLEANING

### CAUTION

Do not press on the meter face (glass) when cleaning; the meter may become damaged.

a. Remove dust and loose dirt with a clean soft cloth or a brush. If it is difficult to remove dirt, dampen the cloth with water; mild soap may be used to make the cleaning more effective.

### WARNING

Prolonged breathing of cleaning compound is dangerous; make certain that adequate ventilation is provided. Cleaning compound is flammable; do not use near a flame. Avoid contact with the skin; wash off any that spills on your hands.

b. Remove grease and ground-in dirt with a cloth moistened (not wet) with Cleaning Compound (FSN 7930-395-9542).

## 6. ORGANIZATIONAL PREVENTIVE MAINTENANCE

Preventive maintenance is the responsibility of all categories of maintenance concerned with the equipment. It includes inspection and tests, and the repair or replacement of parts, subassemblies, or units that these inspections and tests indicate would probably fail before the next scheduled periodic service. Preventive maintenance checks and services of the AN/PDR -27G at the organizational level are made at quarterly intervals at the same time that the daily and weekly checks and services are made, unless otherwise directed by the commanding officer. No lubrication is required.

## 7. MONTHLY MAINTENANCE

Perform the maintenance functions indicated in the organizational maintenance monthly preventive maintenance checks and services table once each month. A month is defined as approximately 30 calendar days of 8-hour-per-day operation. If the equipment is operated 16 hours a day, the monthly preventive maintenance checks and services must be performed at 15-day intervals. Adjust the maintenance interval to compensate for any unusual operating conditions. Equipment maintained in a standby (ready for immediate operation) condition must have monthly preventive maintenance. Equipment in limited storage (requires service before operation) does not require monthly preventive maintenance.

TABLE 6-3. ORGANIZATIONAL MAINTENANCE MONTHLY PREVENTIVE MAINTENANCE CHECKS AND SERVICES

Sequence No.	Item to be inspected	Procedure	References
1	Cable W201 and its retaining hardware	Inspect cable W201 for cut or cracked insulation; inspect packing nuts at each end of cable W201 and retaining ring 0202 (fig. 7-6) for looseness.	Para 5.
2	Headset H-43B/U	Inspect Headset H-43B/U (fig. 1-1) for dirt and grease; check for loose screws and connections.	
3	Operation	Check operation of AN/PDR-27G with Radioactive Test Sample MX-1083B/PDR-27 (sec 3, para 3).	

## 8. QUARTERLY MAINTENANCE

Quarterly preventive maintenance checks and services on **Radiac** Set AN/pdr-27G are required. Periodic monthly services constitute part of the quarterly preventive maintenance checks and services and must be performed concurrently. All deficiencies or short comings will be recorded in accordance with the requirements of TM 38-750. **Perform** all the checks and services listed in the organizational maintenance quarterly preventive maintenance checks and services table in the sequence listed.

TABLE 6-4. ORGANIZATIONAL MAINTENANCE QUARTERLY PREVENTIVE MAINTENANCE CHECKS AND SERVICES

Sequence No.	Item to be inspected	Procedure	References
1	Completeness	Check equipment, including spare parts, for completeness (appx II).	
2	Publications	See that all publications are complete, serviceable, and current.	DA Pam 310-4.
3	Modifications	Check DA Pam 310- <del>4</del> <sup>7</sup> to determine whether new applicable MWO's have been published. All URGENT MWO's must be applied immediately; all NORMAL MWO's must be scheduled.	See 26 1
4	Gaskets	<p>Inspect the following gaskets for cracks and deterioration:</p> <ul style="list-style-type: none"> <li>a. Cable W201 (fig. 1-3) gasket at radiacmeter end.</li> <li>b. Gasket (0129) for calibration port cap 0122 (fig. 1-7).</li> <li>c. Seal for pushbutton assembly A111.</li> <li>d. Seal at headset jack J101 (fig. 1-3).</li> <li>e. Seal between radiacmeter cover and housing.</li> <li>f. Seal between radiacmeter cover and battery well.</li> </ul>	

6-7

TABLE 6-4. ORGANIZATIONAL MAINTENANCE QUARTERLY PREVENTIVE MAINTENANCE CHECKS AND SERVICES (Continued)

*see ch 1*  
*Para. 9*

Sequence No.	Item to be inspected	Procedure	References
5	Preservation	a. Check all painted surfaces for bare spots, rust, and corrosion.  b. Remove rust and corrosion by lightly sanding surfaces with fine sandpaper. Brush two thin coats of paint on bare metal to protect it from further corrosion.	a. None.  <del>b. SB 11-573; TB SIG 364.</del>
	*6 ADDED		

8-9

*see ch 1* Para. 9. ADDED



## SECTION 7

### CORRECTIVE MAINTENANCE

#### 1. GENERAL

This section describes the symptoms produced by malfunctioning of the **radiac** set and the procedures used for localizing and correcting troubles. The most common cause of failure will be dead batteries. Always check the battery condition by turning the meter switch to BATT COND when the radiacmeter is inoperative. When the indicating meter pointer rests to the left of the black line marked BATT, the batteries are depleted and should be replaced. This test, however, checks the condition of **BT103** only. Since it is possible that the other batteries are defective, it is advisable to replace all of the batteries before attempting to trouble shoot the equipment unless the other batteries were recently replaced.

Note that the operation of the radiacmeter, **radiac** detector, and headset can be checked with the radioactive test sample. (See Section 3, par. 3.) This test will yield a qualitative estimate of the performance of the equipment; however, the absolute accuracy of the calibration cannot be determined by this means. The test should be made whenever the existence of trouble is suspected. If an incorrect indication is obtained, note the symptoms of the trouble, then localize the fault as instructed in paragraph 2, below.

#### 2. THEORY OF LOCALIZATION

The radiac set consists essentially of the G-M tubes, the **high-voltage** supply circuit, the pulse shaper and amplifier circuit, the indicating circuit, the headset, and the battery power supply. (See figure 2-2.) Careful consideration of trouble symptoms will usually make it possible to localize the trouble to one or more of the above circuit groups.

Because both aural and visual indications of radiation intensity are provided, troubles can be readily localized by observing whether the fault affects the indicating meter reading, the clicks in the headset, or both. If the headset is inoperative when the meter is indicating the presence of radiation correctly, the fault must lie in the headset and its associated components. If the meter is inoperative when clicks are being obtained in the headset, the



fault must lie in the meter and associated circuit. However, if neither the headset nor the meter respond, the fault must lie in the circuits common to both. In this case, replace **Z101, V104, V103, V102**, and **V101**, one at a time, in the sequence listed, and check for proper operation after each replacement. If the fault persists replace the original tubes and **Z101**, then use the data contained in the voltage-resistance chart (figure 7-1) and in the wave-form chart (figure 7-2) to trouble shoot the **pulse shaper** and amplifier circuit, the high voltage power supply circuit, indicating circuit, and G-M tubes.

If the radiacmeter is inoperative or gives erratic indications on one or two of the ranges only, the trouble can be readily localized by reference to the complete schematic diagram of the radiac set (figure 7-10). Trouble on one range only indicates that section **S101B** (front) of the range switch or the associated resistors are defective. Troubles on both the 0.5 and **5 mr/hr** ranges indicate that **V102** or the probe cable is defective; similarly, trouble on both the **50 and 500 mr/hr** ranges indicates that **V101** is defective.

Note that the voltages applied to the G-M tubes and the pulse shaper and amplifier circuit are regulated. This is done in order to prevent erratic readings as a result of battery aging and other causes. Therefore, if meter readings are erratic, look for trouble in the voltage regulator circuits, and the meter damping circuit.

### 3. **VOLTAGE-RESISTANCE CHART**

(See figure 7-1.)

## CAUTION

Remove batteries from the **radiacmeter** before measuring resistance. Failure to observe this precaution may damage the ohmmeter as well as meter M 101.

Magnitudes of voltage and resistance to ground from the pins at the socket of plug-in unit Z101 and all accessible tubes are contained in the voltage-resistance chart. The conditions under which these readings should be obtained are given in figure 7-1.

### 4. **WAVEFORM CHART**

(See figure 7-2.)

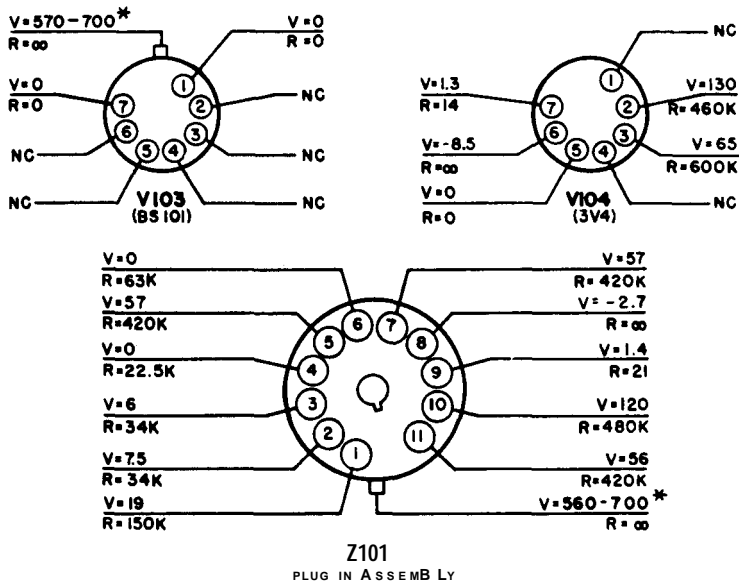
**NOTES:**

1. RESISTANCE MEASUREMENTS FOR Z101 MADE WITH RANGE SWITCH ON 500 AND BATTERIES DISCONNECTED,
2. ALL VOLTAGE READINGS MADE WITH A 20,000  $\Omega/V$  VOLTMETER EXCEPT (\*) IN WHICH CASE THE HIGHER MEASUREMENT WAS MADE WITH AN ELECTRO-STATIC VOLTMETER.
3. ALL RESISTANCES ARE IN OHMS UNLESS OTHERWISE NOTED.
4. ALL VOLTAGES ARE D.C.
5. K = 1000 OHMS.
6. MEG = 1,000,000 OHMS.
7. NC = NO CONNECTION.
8.  $\infty$  = INFINITY.

Figure 7-1. Voltage-Resistance Chart



WAVEFORM	OSCILLOSCOPE LEAD BETWEEN GROUND AND	RANGE SWITCH POSITION	APPROX. AMPLITUDE (VOLTS-PEAK-TO-PEAK)	RADIOACTIVE TEST SAMPLE USED	REMARKS
	Signal grid, pin 6 V-104 (3V4)	500	25	No	None
	Screen grid, pin 3, V-104 (3V4)	50	20	No	None
	Plate, pin 2, V-104 (3V4)	500	2	No	Clip over lead insulation (no direct contact)
	Cap, Z-101	500	15	Yes	Amplitude varies with max 50 volts
	J-101	500	2	Yes	Headset dis-connected
	Pin 6, Z-101	50	12	Yes	None

Figure 7-2. Waveform Chart

Waveforms obtained at significant points in the radiacmeter under normal operating conditions, and the test conditions under which these waveforms are to be obtained are shown in figure 7-2. Be sure to duplicate these conditions accurately when observing the waveforms; if this is not done, the waveforms obtained may differ from those shown in figure 7-2 even though the equipment is operating correctly. These waveforms were obtained with an oscilloscope having a **10-megacycle** band width.

#### 5. TROUBLE SHOOTING CHART

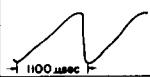
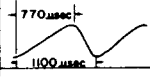
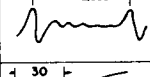
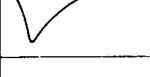
(See table 7-1.)

Commonly encountered trouble symptoms, probable location of faults, and procedures for locating defective components are contained in the trouble shooting chart. Refer to figures 7-3, 7-4, 7-8 and 7-10 for the location of components mentioned in table 7-1.

TABLE 7-1. TROUBLE SHOOTING CHART

Symptom	Probable Location of Fault	Procedure**
1. Meter reads zero with range switch at BATT COND.	Battery connections	Check battery connections for corrosion and loose or broken leads.
	Range switch S101	Check contacts on S101C (front) and S101C (rear). Clean or tighten contacts if necessary
	Meter M101 or multiplier R111	Check M101 and R111.
2. No clicks in headset or indication on meter on any range when unit is tested with radioactive sample.	**High voltage supply circuit	**Measure voltage from cap of V103 to ground, using a 20,000 ohms per volt voltmeter. If less than 435 volts, measure voltages and resistances at V104 socket. For more accurate checking of regulated output voltage, connect a microammeter in series with the cap of V103. (OBSERVE VOLTAGE WARNING**, and POLARITY). If less than 10 microamperes check other components in the high voltage supply circuit (fig 2-7).
	Plug-in unit Z101	Check voltages at socket of plug-in unit Z101. If incorrect,* replace Z101. If fault persists, replace original plug-in unit, and check R101.
	Range switch S101 & headset Jack J101.	Check contacts of S101. Clean or tighten contacts if necessary. Check J101 and C102.

3. No clicks in headset, meter indicates, on any range when unit is tested with radioactive sample.	Headset and J101	Check head set. Check J101.
	Plug-in unit Z101	Check voltages at socket of plug-in unit Z101. If incorrect,* replace Z101. If fault persists, replace original plug-in unit.
4. Clicks in headset on any range but no meter indication, when unit is tested with radioactive sample.	Indication circuit	Check voltages at socket of plug-in unit Z101; if incorrect,* replace Z101. If fault persists, restore original plug-in unit. Check C103, S101C (front), and S101C (rear).
5. No clicks in headset and no meter indication, on one or more ranges when unit is tested with radioactive sample.	G-M tubes	If fault occurs in both 0.5 and 5 mr/hr ranges, replace V102; if fault persists, check probe cable. If fault occurs in both 50 and 500 mr/hr ranges, replace V101. If fault persists restore original tubes.
	Range switch S101 or calibrating resistors	Check contacts on S101A (front) and S101B (front); clean or tighten if necessary. Check R103 through R110.
6. Constant meter reading on all ranges, independent of radiation intensity.	Plug-in unit Z101	*Replace Z101.

\*One spare Z101 is provided in the Maintenance Parts Kit; repairs to the defective Z101 can be made by following instructions contained in par. 7d and 7e.

\*\*WARNING. HIGH VOLTAGE. Avoid bodily contact with high voltage power supply circuit including cap of V103; terminals for CR101, R101, R102, and C101; S101A; anode of BS-2 and cap connector to Z101.

TABLE 7-1. TROUBLE SHOOTING CHART (Continued)

Symptom	Probable Location of Fault	Procedure**
7. Meter reading erratic or abnormally high when unit is tested with radioactive test sample. Note: Do not confuse the normal (slight) fluctuations of the meter pointer with the erratic operation indicated here.	Plug-in unit Z101	Check voltages and waveforms at socket of Z101 if incorrect,* replace Z101. If fault persists, restore original plug-in unit.
	Range switch S101 or calibrating resistors	Check contacts on S101B (front), S101C (front), and S101C (rear); clean and tighten if necessary. Check R103 through R110. Check V103.
8. Meter scales do not change when range switch is rotated.	Meter card positioning mechanism	Check sprocket chain and its spring. Tighten setscrews on sprocket gears.
9. Meter face not illuminated when button on switch is pushed.	Meter illuminating circuit	Check E105, S102, and R116.
10. Meter indicates upscale when turned on, although no radiation energy present.	V105, V106, R117, R118 or R120 in plug-in unit Z101.	*Check resistance between pin 2 of XZ101 and ground; if not between 31K and 35K replace R120 in plug-in unit (See par. 7-d). If normal, remove assembly from can and check other related parts.
	Battery box (A104)	Check for high resistance current path of corrosive material between the terminals of BT102 and BT103; clean if necessary.



<p>11. Meter indication abnormally high; meter appears to be out of calibration</p>	<p>V107 or other parts of low voltage regulating circuit in plug-in Z101.</p>	<p>*Before disassembly of Z101 check voltage at pins 5, 7, and 11; if abnormal remove assembly from can (See par. 7-d) and check individual components.</p>
---	---	---

\*One spare Z101 is provided in the Maintenance Parts Kit; repairs to the defective Z101 can be made by following instructions contained in par. 7d and 7e.

\*\*WARNING. HIGH VOLTAGE. Avoid bodily contact with high voltage power supply circuit including cap of V103; terminals for CR101, R101, R102, and C101; S101A; anode of BS-2 and cap connector to Z101.

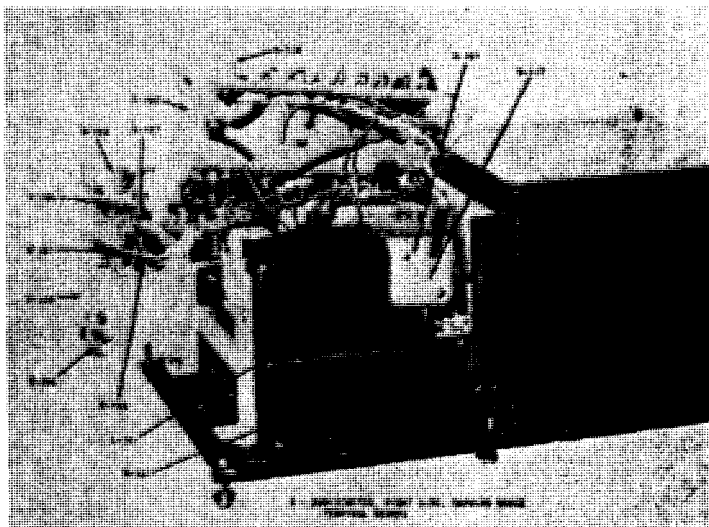
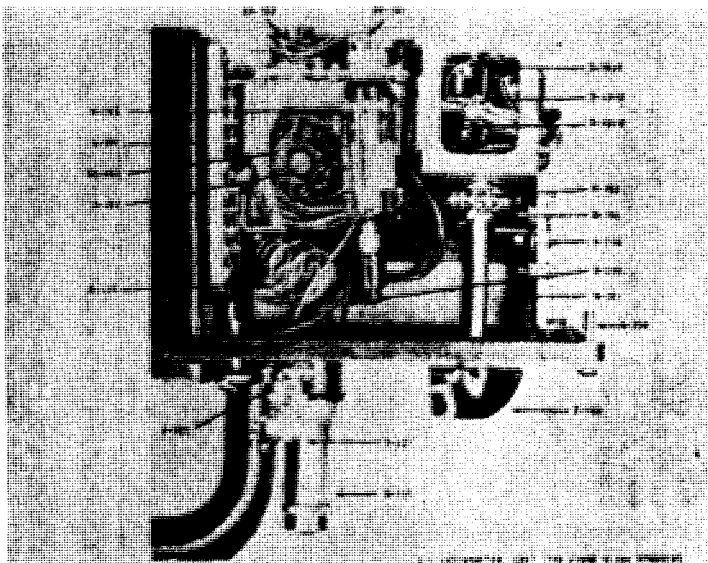

Figure 7-3. Radiometer, Showing Principal Components

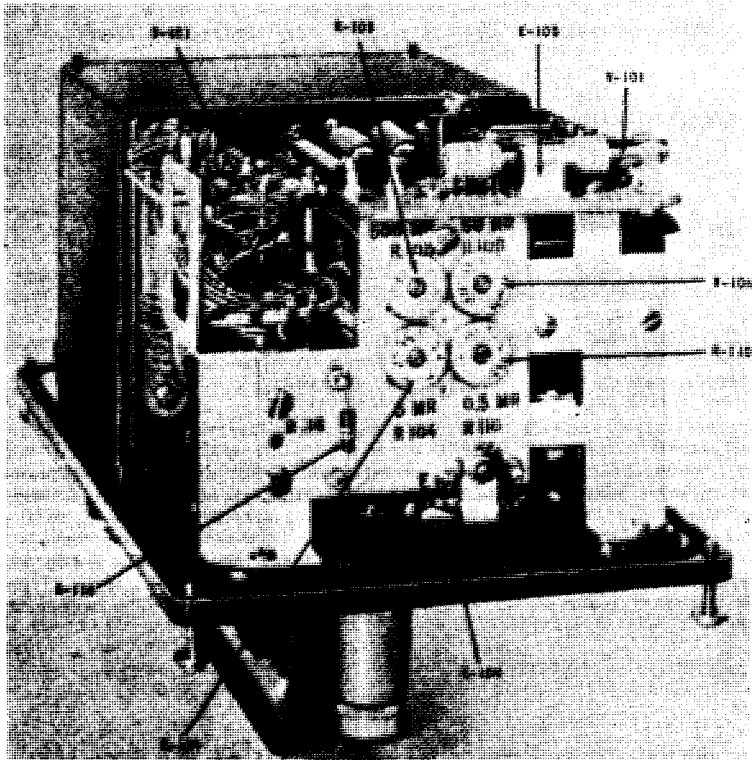

Figure 7-4. Radiacmeter, End View, Showing  
Calibration Potentiometers

6. ~~CALIBRATION~~ *DEIOT CALIBRATION*

**NOTE**

Perform calibration at authorized calibration stations only.

a. GENERAL. -Radiac Set AN/PDR-27G was calibrated when manufactured. Although recalibration may be necessary after replacement or repair of plug-in unit Z 101 or one of the G-M tubes, it is not necessary, ordinarily, when other components or tubes are replaced. Calibration is a tedious and difficult undertaking.

AN/PDR-27G

and, should not be done unless extreme accuracy of indication is required.

The following equipment is required for complete calibration:

Either

*See ch 1* (1) Radiac Calibrator Set AN/UDM-1. *or AN/UDM-1A*

or

(2) (a) An accurately calibrated radium source weighing two (or more) milligrams, or equivalent, and

(b) Accurate rulers or tapes for measuring the distance between the radium source and the radiacmeter.

Calibration must be performed in an area free of large metallic objects. This precaution is necessary in order to avoid inaccuracies in the calibration due to secondary radiation effects.

The mechanical zero of meter M101 has been deliberately suppressed approximately 1 scale division (2 percent of full scale) below the 0 mark on the scale. This has been done to compensate for nonlinearity inherent in G-M tubes. Because of the suppression of the mechanical zero of the meter, the scale indications between 5 percent and 100 percent of full scale represent more accurately the true radiation intensity. Therefore, before performing calibration under paragraph 6b, below, see that the meter pointer rests approximately 1 scale division below the 0 mark on the scale. Move the zero adjust lever on the side of the meter if necessary to effect this setting.

#### b. CALIBRATION PROCEDURE

#### WARNING

Calibration of this equipment necessitates the use of a radioactive substance. Exercise due caution in the handling of the source. Obey all radiation safety precautions. Perform the calibration as rapidly as possible to avoid prolonged exposure to the radiation.

Step 1. Remove the calibration port. Check to see that the beta shield covers the end of the radiac detector, then slip the detector into the well of the radiacmeter.

Step 2. If a Radiac Calibrator Set AN/UTM-1 is not available arrange the equipment as indicated in figure 7-5. Measure and adjust each distance carefully, then observe the radiacmeter indication; if it differs by more than 10 percent from the specified value, adjust the proper calibration potentiometer until the correct value is indicated on the meter. If the weight of the radium source is not 2 milligrams, or if it is desired to calibrate the radiacmeter at intensities not shown in figure 7-5, use the following formula to find the relation between meter indication and distance between radiacmeter and radium source:

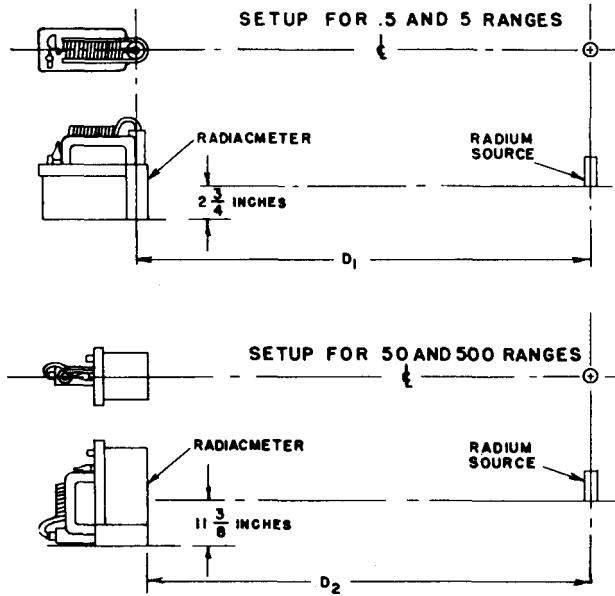

CHECK	RANGE	D <sub>1</sub> INCHES	D <sub>2</sub> INCHES	ADJUST	TO READ MR/HR
1	.5	80.6	—	R-110	.40
2	5.	25.4	—	R-104	4.
3	50.	—	8.06	R-106	40.
4	500.	—	2.54	R-108	400.

NOTE 1. ABOVE VALUES APPLY ONLY TO CALIBRATION BY  
2-MILLIGRAM RADIUM SOURCE.  
NOTE 2. RADIUM SOURCE MUST BE SET UP IN LINE WITH  
DIMPLE IN STEPS 3 AND 4.

Figure 7-5. Calibration Set-Up and Values

$$D = \sqrt{\frac{1.3 \times w}{R/\text{hr}}}$$

where

R/hr = radiation intensity in roentgens per hour

w = weight of radium source in milligrams

D = distance between radiacmeter and radium source  
in inches

- Step 3. After adjusting all ranges, turn range switch to OFF.
- Step 4. Return the radium source to a safe location or remove the equipment from the radiation field of the source.
- Step 5. Replace the calibration port using rounded side of the special wrench.

## 7. REMOVAL AND REPLACEMENT OF PARTS

- a. REMOVAL OF V102. (See figure 7-6.)

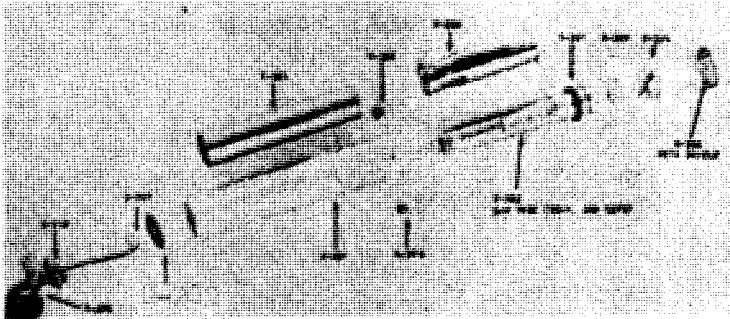

*Figure 7-6. Radiac Detector DT-106/PDR-27G, Exploded View*

- Step 1. Turn the range switch to OFF.
- Step 2. Lift the radiac detector out of the well.
- Step 3. It is not necessary to remove the beta shield 0206, however if desired it may be removed by unscrewing and removing the two screws H208.
- Step 4. Using the spanner end of the special wrench H301 (See figure 1-1) furnished with the equipment, unscrew the retaining ring (0205) and remove it.

### CAUTION

The mica window of V102 is 0.0005-inch thick. Do not touch this window under any conditions. Damage to the tube will result.

7-14

6.1 ADDED

- Step 5. Being careful not to touch the mica window of V102, lift out the guard H204.
- Step 6. Unscrew threaded ring at the cord end of the probe using the spanner end of the special wrench. Remove the cap; be careful not to lose the "O" ring.
- Step 7. Using long-nosed pliers, remove the anode clip 0207 from the V102 anode cap.
- Step 8. With your thumb, push the anode cap lightly into the housing, causing V102 to slide out of the front end of the probe housing. To prevent damage to the lead Shield E201, care should be taken to prevent the mounting cylinder 0208 from sliding out with V102.

b. REPLACEMENT OF V102. (See figure 7-6.)

- Step 1. Slip the "O" ring over the anode end of V102, then roll the ring 0201 along the tube to within 1/2-inch of the flange near the mica window.
- Step 2. Slide V102 into the housing until it is stopped by the "O" ring. Do not attempt to install the tube in any other manner. The 1/2-inch spacing of the "O" ring on the tube is essential so that the ring may slip into its proper position when the tube is inserted in its housing.
- Step 3. Use a large flat surface, being careful not to touch the mica window. Hold the probe in a vertical position, with the window end of the tube against the flat surface. Exert light pressure until V102 rolls into its housing.
- Step 4. Still holding the probe with the window facing down, replace the guard in the retaining ring. Screw the retaining ring into the housing and tighten with the spanner end of the special wrench.
- Step 5. Insert the "O" ring in the rear of the housing,
- Step 6. Using long nosed pliers, place the anode clip on the V102 anode cap.
- Step 7. Screw the threaded ring into the rear of the housing. Using the spanner end of the special wrench, tighten the cap. Then tighten the cable packing nut.

Step 8. Replace the beta shield on the front of the probe.

c. REPLACING HIGH VOLTAGE AMPLIFIER V104 (3V4) TUBE. -In some 3V4 tubes, the plate current will not cut off at high voltages as required for proper operation in this equipment. In such cases the current through the High Voltage Regulator V103 (BS-101) will be less than 15 microampere, which is the minimum requirement for proper operation.

Therefore, when replacing the 3V4 tube it may sometimes be necessary to try several tubes in order to select one which will give satisfactory operation.

d. REMOVAL AND DIS-ASSEMBLY OF Z101 (See fig 7-3 and 7-7).

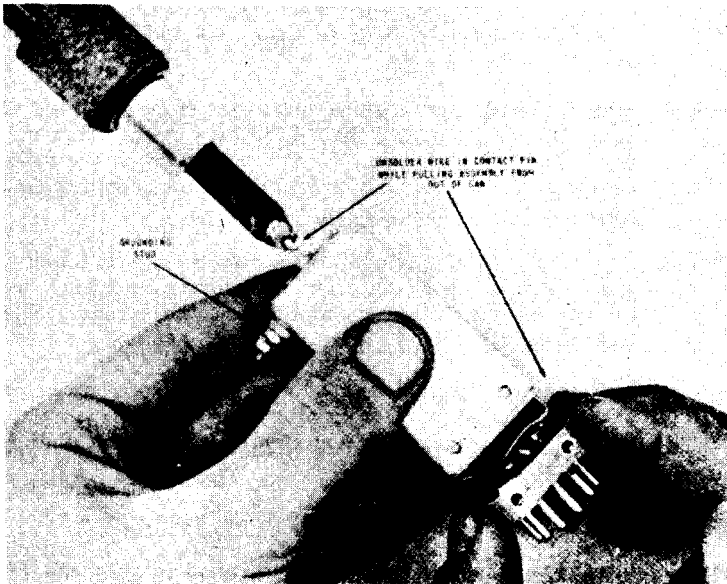

Figure 7-7. Trigger Amplifier Z-101, Disassembly

Step 1. Turn range switch to OFF.



- Step 2. Remove radiacmeter assembly from housing and lift clip 0117 from cap of Z101.
- Step 3. Using wrench H301, loosen nut which grounds and holds stud of Z101 to chassis frame. If difficult to grasp Z101 to pull out of socket, use blunt end of pencil to push on locating pin end of Z101 while working top of the unit gently side to side and out.
- Step 4. After removal from the radiacmeter, remove the four screws around the base of Z101. Do not remove grounding stud.
- Step 5. Apply hot soldering iron to contact pin while pulling assembly from out of the can (fig. 7-7).
- Step 6. To gain access to the innermost parts of the assembly, pull the side pieces of the assembly out of their slots; all components are then accessible for replacement if necessary (See fig. 7-8).

e. RE -ASSEMBLY AND REPLACEMENT OF Z101 (fig. 7-9)

- Step 1. Replace side pieces by fitting into slots provided, being careful to fit all parts snugly together.
- Step 2. Connect a piece of #20 gauge solid tinned bus wire approximately 4 inches long to the projecting lead of C113 (See figures 7-8 and 7-9). Bend the soldered joint carefully in the manner shown in figure 7-8.
- Step 3. Try the bus wire in the hole in the contact pin. If the wire does not go thru the hole easily use hot soldering iron to free excess solder from the hole.
- Step 4. Position the teflon tape inside the can as shown in figure 7-9 and orient the base assembly properly with respect to the grounding stud on the can. Also check that the ground clip at the base of Z101 is properly located.
- Step 5. Start the bus wire up thru the hole in the contact pin and slide the assembly gently into the can. CAUTION - the assembly should slide snugly into the can, if abnormally tight remove from can and check to see that all parts are snugly positioned in slots and soldered connections do not project.

# 7 Section

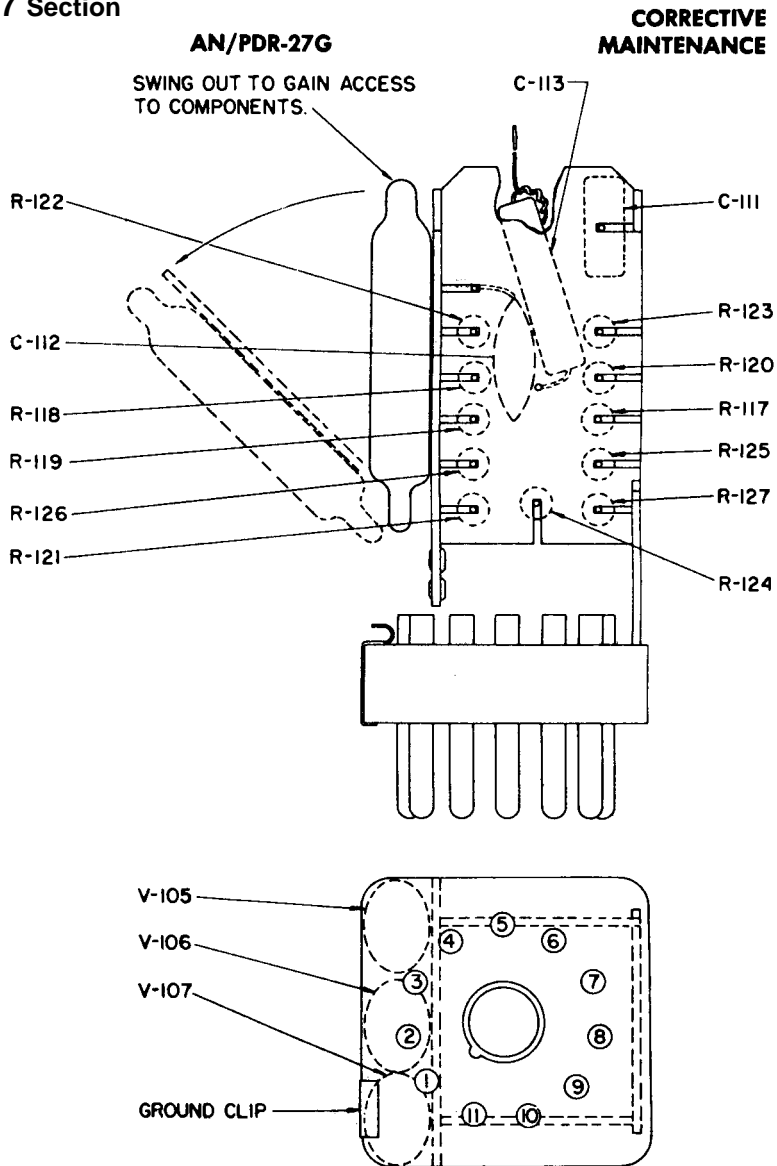

Figure 7-8. Trigger Amplifier Z-101, Internal Components Layout

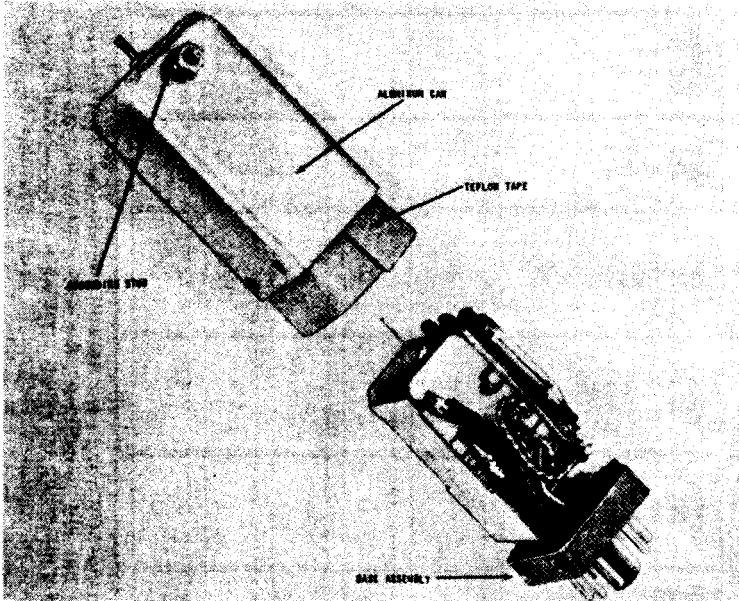

Figure 7-9. Trigger Amplifier Z-101, Preparation for Re-assembly

**Step 6.** After assembly into the can, replace the four screws at the base of the can, checking that the ground clip is properly mounted. Before replacing in radiacmeter, check resistance measurements for agreement with those given in figure 7-1.

**Step 7.** Plug into socket, tighten nut on grounding stud, and replace clip to the contact pin.

#### 8. COMPONENT CHARACTERISTICS

a. ELECTRON TUBES - Table 7-2 lists the operating voltages and currents of all tubes in the radiac set. Table 7-3 lists the characteristics of all the tubes in the radiac set.

#### NOTE

All tubes of a given type supplied with the equipment shall be consumed prior to employment of tubes from general stock.

TABLE 7-2. TUBE OPERATING VOLTAGES AND CURRENTS(a)

Tube Type	Function	Plate (V)	Plate (Ma)	Screen (V)	Screen (MA)	Cathode (V)	Grid (V)	Heater DC (V)
3V4	High-voltage power supply amplifier tube	135 to 110	1.5	86 to 62	0.13 to 0.03(d)	0 (b)	-6.0 (c)	1.3
BS-1	Radiation detector (Low sensitivity)	430 to 635 (e)	*700 (e)	0		0		
BS-2	Radiation detector (High sensitivity)	430 to 635 (f)	*700 (f)	0		0		
BS-101	High voltage regulator	440 to 635	*700	.025		0		
CK502AX	(V105) Pulse shaper and amplifier	20		.018		6.8	3.7	1.5
CK502AX	(V106) Pulse shaper and amplifier	57		0		6.8	0	1.5
CK502AX	(V107) Shunt voltage regulator	57		.305		0	-2.7	1.5

\*Electrostatic voltmeter measurement. (a) Unless indicated by (\*) all measurements made with 20,000 ohms/volt meter. (b) At pin #5. (c) Voltmeter set on 50V range for this measurement. (d) Screen current of 3V4 not significant due to wide variance caused by different constants of associated components. (e) With radiacmeter range switch on the 5 or .5 MR/H range. (f) With radiacmeter range switch on any of the 4 active ranges.

TABLE 7-3. TUBE CHARACTERISTICS

Characteristics	Tube Type				
	3V4	BS-1	BS-2	BS-101	CK502AX
Filament Voltage (V)	1.4				1.5
Filament Current (A)	0.05				
Plate Voltage (V)	90	700	700	700	45
Grid Bias (V)	-4.5				-1.5
Screen Voltage (V)	90				45
Plate Current (Ma)	7.7	(too small to be measured)	(too small to be measured)	0.020	0.6
Screen Current (Ma)	1.7				0.15
A-C Plate Resistance (Ohms)	120,000				200,000
Transconductance (Micromhos)					
Normal	2000				550
Minimum	1500				---

TABLE 7-4. APPLICABLE COLOR CODES AND MISCELLANEOUS DATA

### CAPACITOR COLOR CODES

**RMA 3-DOT COLOR CODE FOR MICA-DIELECTRIC CAPACITORS**

**JAN 6 DOT COLOR CODE FOR PAPER-DIELECTRIC CAPACITORS**

**RMA 6-DOT COLOR CODE FOR MICA-DIELECTRIC CAPACITORS**

**JAN 8-DOT COLOR CODE FOR MICA-DIELECTRIC CAPACITORS**

**RMA COLOR CODE FOR TUBULAR CERAMIC-DIELECTRIC CAPACITORS**

**JAN COLOR CODE FOR FIVED CERAMIC-DIELECTRIC CAPACITORS**

**JAN COLOR CODE FOR FIVED CERAMIC-DIELECTRIC CAPACITORS**

**RMA RADIO MANUFACTURERS ASSOCIATION  
JAN - JONV - ARMY - NAVY**

RESISTORS				CAPACITORS				
TOLERANCE	MULTIPLIER	SIGNIFICANT FIGURE	COLOR	RMA MICA AND CERAMIC-DIELECTRIC	JAN MICA AND PAPER-DIELECTRIC	JAN CERAMIC-DIELECTRIC	VOLTAGE RATING	TEMPERATURE COEFFICIENT
	1	0	BLACK	1	10	10	100	A
	10	1	BROWN	10	100	100	200	B
	100	2	RED	100	1000	1000	300	C
	1000	3	ORANGE	1000	10000	10000	400	D
	10000	4	YELLOW	10000	100000	100000	500	E
	100000	5	GREEN	100000	1000000	1000000	600	F
	1000000	6	BLUE	1000000	10000000	10000000	700	G
	10000000	7	VIOLET	10000000	100000000	100000000	800	
	100000000	8	GRAY	100000000	1000000000	1000000000	900	
	1000000000	9	WHITE	1000000000	10000000000	10000000000	1000	
3	0.1		GOLD	0.1	0.1	0.1	500	
10	0.01		SILVER	0.01	0.01	0.01	2000	
20			NO COLOR				500	

### RESISTOR COLOR CODES

**RMA COLOR CODE FOR FIVED COMPOSITION RESISTORS**

**RADIAL TYPE**

**JAN COLOR CODE FOR FIVED COMPOSITION RESISTORS**

**RADIAL TYPE NON-INSULATED**

AN/PDR-27G

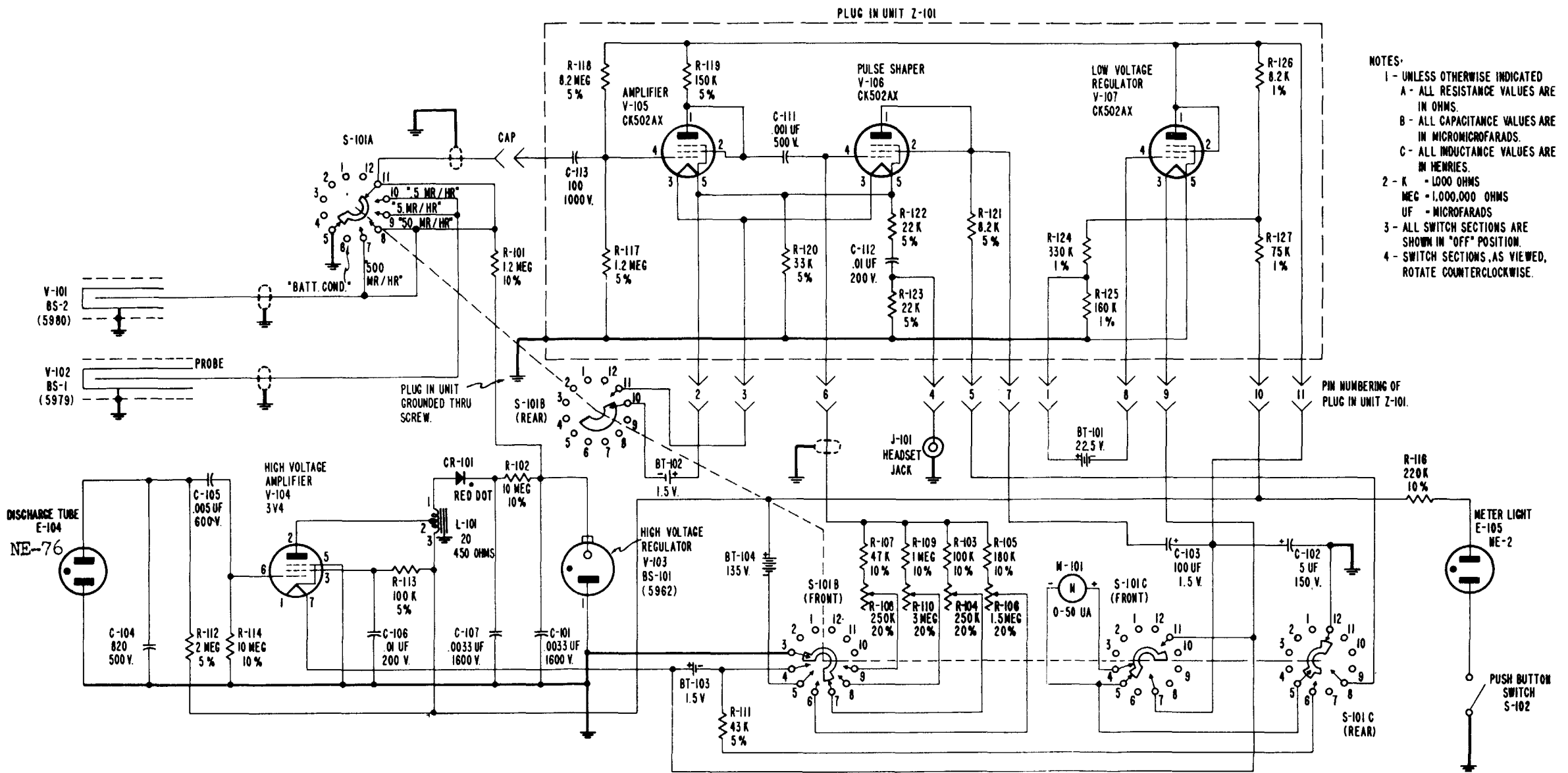

Figure 7-10. Radiac Set AN/PDR-27G, Schematic Diagram

AN/PDR-27G

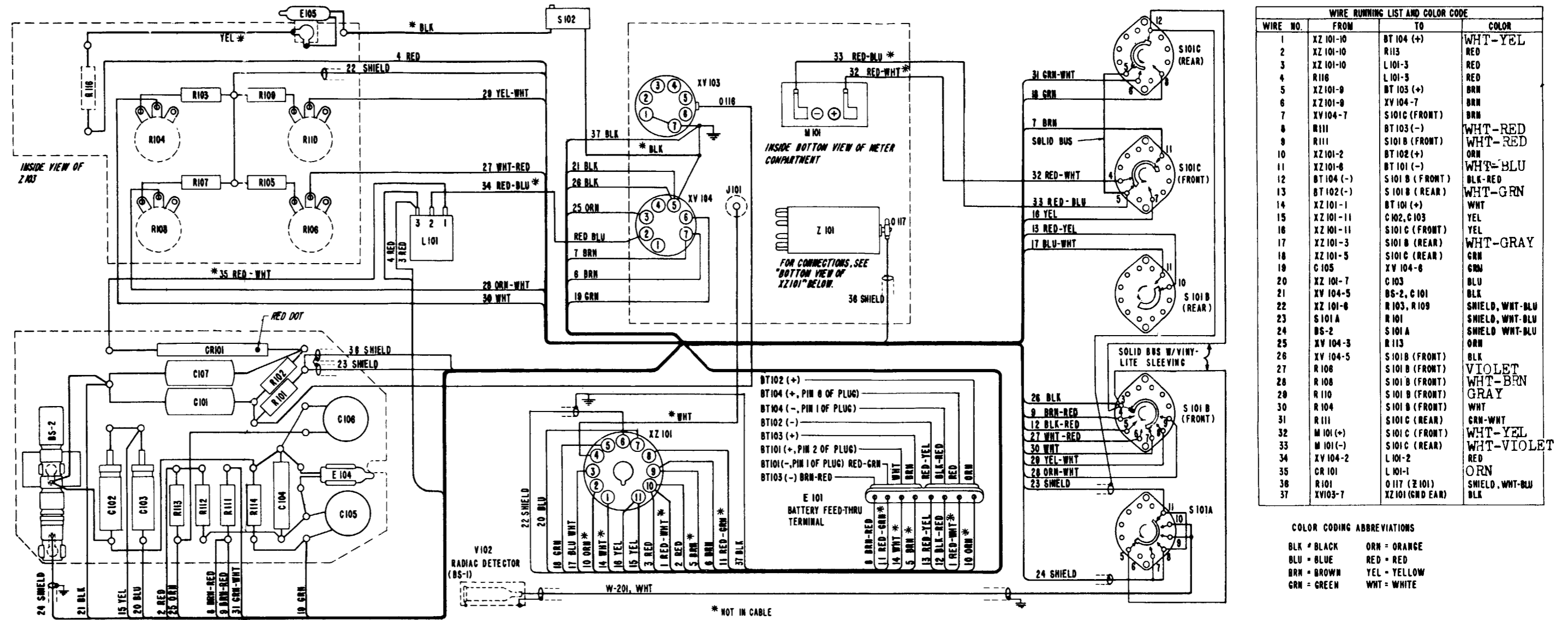

Figure 7-11. Radiac Set AN/PDR-27G, Wiring Diagram



## REFERENCES

---

Following is a list of applicable references available to the operating and maintenance personnel of Radiac Set AN/PDR-27G.

AR 700-52	Logistics: Licensing and Control of Radioactive Materials.
AR 755-380	Disposal of Supplies and Equipment: Disposal of Unwanted Radioactive Material.
DA Pamphlet 310-4	Index of Technical Manuals, Technical Bulletins, Supply Manuals (Types 7, 8, and 9), Supply Bulletins, Lubrication Orders, and Modification Work Orders.
SB 11-573	Painting and Preservation Supplies Available for Field Use for Electronics Command Equipment.
SB 38-100	Preservation, Packaging, and Packing Materials, Supplies, and Equipment Used by the Army.
TB 11-6625-274-12/1	Test Data for Electron Tube Test Sets TV-7/U, TV-7A/U, TV-B/U, and TV-7D/U.
TB SIG 225	Identification and Handling of Radioactive Signal Item.
TB SIG 364	Field Instructions for Painting and Preserving Electronics Command Equipment.
TM 11-1176	Radiac Calibrator Set AN/UDM-1.
TM 11-1214	Instruction Book for Oscilloscope os-8A/U.
TM 11-1214A	Oscilloscope os-8c/U.
TM 11-5527	Multimeters TS-352/U, TS-352A/U, and TS-352B/U.

TM 11-6625-274-12	Operator's and Organizational Maintenance Manual: Test Sets, Electron Tube TV-7/U, TV-7A/U, TV-7B/U, and TV-7D/U.
TM 11-6625-316-12	Operator and Organizational Maintenance Manual: Test Sets, Electron Tube TV-2/U, TV-2A/U, TV-2B/U, and TV-2C/U.
TM 11-6665-204-12	Operator and Organizational Maintenance Manual: Calibrator Sets, Radiac TS -784/PD and TS-784A/PD.
TM 38-750	Army Equipment Record Procedures.

APPENDIX II  
BASIC ISSUE ITEMS LIST

Section I. INTRODUCTION

1. General

~~a. This appendix lists items supplied for initial operation. The list includes tools, parts, and material issued as part of the major end item. The list includes all items authorized for basic operator maintenance of the equipment. End items of equipment are issued on the basis of allowances prescribed in equipment authorization tables and other documents that are a basis for requisitioning.~~ *Suppl. Cont. 1*

~~b. Columns are as follows:~~

- ~~(1) Federal stock number. This column lists the 11-digit Federal stock number.~~
- ~~(2) Designation by model. Not used.~~
- ~~(3) Description. Nomenclature or the standard item name and brief identifying data for each item are listed in this column. When requisitioning, enter the nomenclature and description.~~
- ~~(4) Unit of issue. The unit of issue is each unless otherwise indicated and is the supply term by which the individual item is counted for procurement, storage, requisitioning, allowances, and issue purposes.~~
- ~~(5) Expendability. Nonexpendable items are indicated by NX. Expendable items are not annotated.~~
- ~~(6) Quantity authorized. Under "Items Comprising an Operable Equipment", the column lists the quantity of items supplied for the initial operation of the equipment.~~
- ~~(7) Illustration. The "Item No." column lists the reference designations that appear on the part in the equipment. These same designations are also used on any illustrations of the equipment. The numbers in the "Figure No." column refer to the illustrations where the part is shown.~~

2. Batteries

~~Dry batteries shown are used with the equipment but are not considered part of the equipment. They will not be preshipped automatically but are to be requisitioned in quantities necessary for the particular organization, in accordance with SB 11-6.~~



## SECTION II. BASIC ISSUE ITEMS LIST

FEDERAL STOCK NUMBER	DESIGNATION BY MODEL	DESCRIPTION	UNIT OF ISSUE	EXP	QTY AUTH	ILLUSTRATION	
						FIGURE NO.	ITEM NO.
6665-543-1443		RADIAC SET AN/PDR-27G: For detecting and measuring rate of received beta and gamma radiations together, or gamma radiations alone. Range of detector 0-500 milliroetgens per hour. Scale 0-.5, 0-5, 0-50, 0-500 MR/hr.		NX			
		ITEMS COMPRISING AN OPERABLE EQUIPMENT					
ORD THRU AGC		TECHNICAL MANUAL TM11-6665-228-15			2		
6665-547-1040		CASE CY-963A,B,C/PDR-27A		NX	1	1-1	
6665-392-7466		HARNESS ST-125A/PDR-27E			1	1-1	
6665-515-5891		RADIACMETER IM-74B/PDR-27C		NX	1	1-3	
6665-694-2021		RADIOACTIVE TEST SAMPLE MX-1083B/PDR-27			1	3-3	
6135-164-8753		RADIACMETER IM-74B/PDR-27C					
6135-164-8753		BATTERY, DRY BA-401/U: (For reference only)				1-1	BT102 BT103
6135-164-8754		BATTERY, DRY BA-413/U: (For reference only)				3-2	BT101
6135-164-8768		BATTERY, DRY BA-416/U: (For reference only)				1-1	BT104
5120-383-0964		WRENCH, OPEN END, FIXED: Admiral p/n 515A174, Specialty p/n MI-3		NX	1	1-1	H301
5120-224-2504		WRENCH, SOCKET HEAD, HEX: 5/64 in across flats, 1-31/32 in lg, for No. 8 setscrew		NX	1	1-1	H302
		RUNNING SPARE ITEMS					
		NO PARTS AUTHORIZED FOR STOCKAGE AT OPERATOR'S LEVEL					

ATI-2

APPENDIX III

MAINTENANCE ALLOCATION

---

Section I. INTRODUCTION

1. General

a. This appendix assigns maintenance functions to be performed on components, assemblies, and subassemblies by the lowest appropriate maintenance category.

b. Columns in the maintenance allocation chart are as follows:

- (1) **Part or component.** This column shows only the nomenclature or standard item name. Additional descriptive data are included only where clarification is necessary to identify the component. Components, assemblies, and subassemblies are listed in top-down order. That is, the assemblies which are part of a component are listed immediately below that component, and subassemblies which are part of an assembly are listed immediately below that assembly. Each generation breakdown (components, assemblies, or subassemblies) is listed in disassembly order or alphabetical order.
- (2) **Maintenance function.** This column indicates the various maintenance functions allocated to the categories.
  - (a) **Service.** To clean, to preserve, and to replenish lubricants.
  - (b) **Adjust.** To regulate periodically to prevent malfunction.
  - (c) **Inspect.** To verify serviceability and detect incipient electrical or mechanical failure by scrutiny.
  - (d) **Test.** To verify serviceability and to detect incipient electrical or mechanical failure by use of special equipment such as gages, meters, etc.
  - (e) **Replace.** To substitute serviceable components, assemblies, or subassemblies, for unserviceable components, assemblies, or subassemblies.
  - (f) **Repair.** To restore an item to serviceable condition through correction of a specific failure or unserviceable condition. This function includes but is not limited to welding, grinding, riveting, straightening, and replacement of parts other than the trial and error replacement of running spare type items such as fuses, lamps, or electron tubes.
  - (g) **Align.** To adjust two or more components of an electrical system so that their functions are properly synchronized.

- (h) Calibrate. To determine, check, or rectify the graduation of an instrument, weapon, or weapons system, or components of a weapons system.
- (i) Overhaul. To restore an item to completely serviceable condition as prescribed by serviceability standards developed and published by heads of technical services. This is accomplished through employment of the technique of "Inspect and Repair Only as Necessary" (IROAN). Maximum utilization of diagnostic and test equipment is combined with minimum disassembly of the item during the overhaul process.
- (j) Rebuild. To restore an item to a standard as near as possible to original or new condition in appearance, performance, and life expectancy. This is accomplished through the maintenance technique of complete disassembly of the item, inspection of all parts or components, repair or replacement of worn or unserviceable elements using original manufacturing tolerances and/or specifications and subsequent reassembly of the item.
- (3) Operator, organizational, direct support, general support, and depot. The symbol X indicates the categories responsible for performing that particular maintenance operation, but does not necessarily indicate that repair parts will be stocked at that level. Categories higher than those marked by X are authorized to perform the indicated operation.
- (4) Tools required. This column indicates codes assigned to each individual tool equipment, test equipment, and maintenance equipment referenced. The grouping of codes in this column of the maintenance allocation chart indicates the tool, test, and maintenance equipment required to perform the maintenance function.
- (5) Remarks Entries in this column will be utilized when necessary to clarify any of the data cited in the preceding Column.

c. Columns in the allocation of tools for maintenance functions are as follows:

- (1) Tools required for maintenance functions. This column lists tools, test, and maintenance equipment required to perform the maintenance functions.
- (2) Operator, organizational, direct support, general support, and depot. The dagger (†) symbol indicates the categories normally allocated the facility.
- (3) Tool code. This column lists the tool code assigned.

## 2. Maintenance by Using Organizations

When this equipment is used by signal services organization organic to theater headquarters or communication zones to provide theater communications, those maintenance functions allocated up to and including general support are authorized to the organization operating this equipment.





## SECTION II. MAINTENANCE ALLOCATION CHART

PART OR COMPONENT	MAINTENANCE FUNCTION	MAINTENANCE CATEGORY					TOOLS REQUIRED	REMARKS
		O/C	O	DS	GS	D		
RADIAC SET AN/PDR-27G	service	X						Batteries
	inspect	X					1,2,3,6	
	test				X		1,2,3,4,5,10	
	replace	X				X	7	
	repair		X				7,9	
	calibrate				X		1,2,5,7,8,9	
CASE CY-963, A,B,C/PDR-27A	rebuild				X	X	1,2,3,4,5	Depot Facilities & Parts Fabrication
	overhaul				X	X	1,2,3,6 1,2,3,4,5,7,8,9	
CASE CY-963, A,B,C/PDR-27A	replace	X						For Maint Allocation See TM 11-5965-247-12P
repair						X		
HEADSET, ELECTRICAL H-43B/U	replace		X					
RADIACMETER IM-74B/PDR-27C	replace		X					7.9
	repair		X					

## SECTION III. ALLOCATION OF TOOLS FOR MAINTENANCE FUNCTIONS

TOOLS REQUIRED FOR MAINTENANCE FUNCTIONS	MAINTENANCE CATEGORY					TOOL CODE	TYPE CLASS
	O/C	O	DS	GS	D		
AN/PDR-270 (Continued)							
MULTIMETER TS-352/U				+	+	1	ARMY, STD A
OSCILLOSCOPE OS-8/U				+	+	2	NAVY, STD A
RADIAC CALIBRATOR TS-784/PD				+	+	3	ARMY, STD A
RADIAC CALIBRATOR SET AN/UDM-1					+	4	NAVY, STD A
TEST SET, ELECTRON TUBE TV-2/U					+	5	ARMY, STD A
TEST SET, ELECTRON TUBE TV-7/U				+		6	ARMY, STD A
SCREWDRIVER TL-358/U	+	+		+	+	7	ARMY, STD A
TOOL KIT TK-87/U				+	+	8	ARMY, STD A
WRENCH TL-111/U			+	+	+	9	ARMY, STD A
ELECTROSTATIC VOLTMETER 1500V					+	10	(COMMERCIAL-SENSITIVE RESEARCH CCAM No. E.S.D. ELECTA)

## APPENDIX IV

### ORGANIZATIONAL, DIRECT AND GENERAL SUPPORT AND DEPOT REPAIR PARTS LISTS

---

#### Section I. INTRODUCTION

##### 1. General

a. This appendix contains organizational, direct and general support and depot repair parts and special tools lists.

- (1) The Organizational maintenance repair parts and special tools list lists repair parts authorized for organizational maintenance and is a basis for requisitioning by organizations which are authorized the major item of equipment. End items of equipment are issued on the basis of allowances prescribed in equipment authorization tables and other documents that are a basis for requisitioning.
- (2) The direct and general support and depot, maintenance repair parts and special tools list lists the quantities of repair parts authorized for direct and general support maintenance and is a basis for requisitioning authorized parts. It is also a guide for depot maintenance in establishing initial levels of spare parts.

##### **b. Columns are as follows:**

- (1) Source, maintenance, and recoverability code. Source, maintenance, and recoverability codes indicate the technical service responsible for supply, the maintenance category at which an item is stocked, categories at which an item is installed or repaired, and whether an item is repairable or salvageable. The source code column is divided into four parts.
  - (a) Column A. This column indicates the materiel code and designates the area of responsibility for supply. AS 310-1 defines the basic numbers used to identify the materiel code. If the part is Signal materiel responsibility, the column is left blank.
  - (b) Column B. This column indicates the point within the maintenance system where the part is available. "P" indicates that the repair part is a high mortality part; procured by technical services, stocked in and supplied from the technical service depot system, and authorized for use at indicated maintenance categories. "P1" indicates that the repair part is a low mortality part; procured by technical services, stocked only in and supplied from technical service key depots, and authorized for installation at indicated maintenance categories.

- (c) Column C. This column indicates the lowest maintenance category authorized to install the part.  
"O" - Organizational maintenance (operator and organizational).  
"H" - Direct support maintenance.
- (d) Column D. Not used.
- (2) Federal stock number. This column lists the 11-digit Federal stock number.
- (3) Designation by model. Not used.
- (4) Description. Nomenclature or the standard item name and brief identifying data for each item are listed in this column. When requisitioning, enter the nomenclature and description.
- (5) Unit of issue. The unit of issue is each unless otherwise indicated and is the supply term by which the individual item is counted for procurement, storage, requisitioning, allowances, and issue purposes.
- (6) Expendability. Nonexpendable items are indicated by NX. Expendable items are not annotated.
- (7) Quantity incorporated in unit. This column lists the quantity of each part found in a given assembly, component, or equipment.
- (8) Organizational. An asterisk (\*) indicates that an item is not authorized for stockage but if required, may be requisitioned for immediate use only.
- (9) Direct support. No parts authorized for stockage.
- (10) General support. The numbers in this column indicate quantities of repair parts authorized- for initial stockage for use in general support maintenance. The quantities are based on 100 equipments to be maintained for a 15-day period.
- (11) Depot. The numbers in this column indicate quantities of repair parts authorized for depot maintenance and for initial stockage for maintenance, and for supply support to lower categories. The entries are based on the quantity required for rebuild of 100 equipments.
- (12) Illustration. The "Item No." column lists the reference designations that appear on the part in the equipment. These same designations are also used on any illustrations of the equipment. The numbers in the "Figure No." column refer to the illustrations where the part is shown,

## 2. Parts for Maintenance

When this equipment is used by signal service organizations organic to theater headquarters or communication zones to provide theater communications, those repair parts authorized up to and including general support are authorized for stockage by the organization operating this equipment.

## 3. Electron Tubes

The consumption rates given for tubes are conservative theoretical estimates and are provided for use only when more complete information, such as data based on operating experience, is not available. These figures are based on levels and requirements for equipment actually in use, not on authorizations or equipment stored in depots.

### b. Requisitioning Information

a. The allowance factors are based on 100 equipments. In order to determine the number of parts authorized for initial stockage for the specific number of equipments supported, the following formula will be used and carried out to two decimal places.

$$\text{specific number of equipments supported} \times \frac{\text{allowance factor}}{100} =$$

Number of parts authorized for initial stockage.

b. Fractional values obtained from above computation will be rounded to whole numbers as follows:

- (1) When the total number of parts authorized is less than 0.5, the quantity authorized will be zero.
- (2) When the total number of parts authorized is between 0.5 and 1.0, the quantity authorized will be one.
- (3) For all values above one, fractional values below 0.5 will revert to the next lower whole number and fractional value 0.5 and above will advance to the next higher whole number.

c. The quantities determined in accordance with the above computation represent the initial stockage for a 15-day period.



## SECTION II. ORGANIZATIONAL FUNCTIONAL PARTS LIST

FEDERAL STOCK NUMBER	DESIGNATION BY MODEL	DESCRIPTION	UNIT OF ISSUE	EXP	QTY IN UNIT	ORGANIZATIONAL	ILLUSTRATION	
							FIGURE NO.	ITEM NO.
6665-543-1443		RADIAC SET AN/PDR-27G: For detecting and measuring rate of received beta and gamma radiations together, or gamma radiations alone. Range of detector 0-500 milliroetgens per hour. Scale 0-.5, 0-5, 0-50, 0-500 MR/hr.		NX			1-1	
5355-284-4571		RADIAC METER IM-74B/PDR-27G KNOB: Rogan Bros p/n RB-41 (range switch)			1	*	1-3	E106



## SECTION III. GENERAL SUPPORT AND DEPOT FUNCTIONAL PARTS LIST

SOURCE CODE				FEDERAL STOCK NUMBER	DESIGNATION BY MODEL	DESCRIPTION	UNIT OF ISSUE	EXP	QTY IN UNIT	DIRECT SUPPORT	GENERAL SUPPORT	DEPOT	ILLUSTRATION	
													FIGURE NO.	ITEM NO.
A	B	C	D											
				6665-543-1443		RADIAC SET AN/PDR-27G: For detecting and measuring rate of received beta and gamma radiations together, or gamma radiations alone. Range of detector 0-500 milliroetgens per hour. Scales 0-.5, 0-5, 0-50, 0-500 MR/hr.  CASE CY-963 A, B, C/PDR-27A		NX					1-1	
	Pl	H		6665-880-1208		HOLDER, RADIAC SAMPLE: Specialty Electronics dwg No. M1-1J  RADIACMETER IM-74B/PDR-27C			1		0.2	3.0	1-1	
	P	H		6665-392-7468		AMPLIFIER, TRIGGER: Admiral p/n GC329			1		4.2	4.0	7-3	Z101
	P	H		5910-649-4447		CAPACITOR, FIXED, CERAMIC DIELECTRIC: 3000 mmf +100%, -0%, 1600 vdcw, Centralab p/n DD16-302			2		4.2	10.0	1-5	C101, C107
	P	H		5910-280-7037		CAPACITOR, FIXED, CERAMIC DIELECTRIC: 5000 mmf, 600 vdcw, Centralab type No. DD-502			1		4.2	5.0	1-5	C105
	P	H		5910-666-8075		CAPACITOR, FIXED, CERAMIC DIELECTRIC: Admiral dwg No. 565A1-3			1		4.2	5.0	1-5	C106
	P	H		5910-101-4032		CAPACITOR, FIXED, MICA DIELECTRIC: MIL type CM25B821J			1		4.2	5.0	1-5	C104
	P	H		5910-270-9489		CAPACITOR, FIXED, ELECTROLYTIC: 5 mf, 150 vdcw, Cornell-Dublier p/n BBR-5-150			1		4.2	5.0	1-5	C102
	P	H		5910-281-0714		CAPACITOR, FIXED, ELECTROLYTIC: Cornell-Dublier p/n BBR-100-1.5			1		4.2	5.0	1-5	C103
	Pl	H		4010-141-7642		CHAIN: Fed Spec No. RR-C-271, type B			1		0.5	3.0	7-3	H101
	Pl	H		5940-259-4989		CLIP, ELECTRICAL: Hughes Aircraft p/n 420-53-4139			1		0.5	4.0		0113
	Pl	H		5940-151-4035		CLIP, ELECTRICAL: Littlefuse p/n 123002			1		0.5	4.0		0109
	Pl	H		5940-295-5769		CLIP, ELECTRICAL: Hoffman p/n AS-944			1		0.5	4.0	7-3	0110

5-AIV

SOURCE CODE				FEDERAL STOCK NUMBER	DESIGNATION BY MODEL	DESCRIPTION	UNIT OF ISSUE	EXP	QTY IN UNIT	DIRECT SUPPORT	GENERAL SUPPORT	DEPOT	ILLUSTRATION	
													FIGURE NO.	ITEM NO.
A	B	C	D			AN/PDR-27G (Continued)								
	PIH			6665-500-5409		CLIP, ELECTRICAL: Admiral p/n 590A3-2			1		0.5	4.0	1-6	0116
	PIH			5940-242-4955		CLIP, ELECTRICAL: Millen Mfg. Co. p/n 36021			1		0.5	4.0	7-3	0117
	P	H		5935-237-6663		CONNECTOR, PLUG, ELECTRICAL: Eby p/n 9706-3			2		4.2	10.0	3-2	P101, P102
	P	H		5935-201-3511		CONNECTOR, RECEPTACLE, ELECTRICAL: Type UG-290A/V			1		4.2	5.0	1-3	J101
	P	H		6665-228-4278		CORD ASSEMBLY: Whitney Blake p/n 192-1			1		4.2	10.0	1-3	W201
	PIH			5935-258-1767		COVER, ELECTRICAL CONNECTOR: Type CW-123A/U			1		0.5	3.0	1-3	0121
	P	H		6665-171-6167		DETECTOR, RADIAC: DT-106/PDR-27G		NX	1		4.2	4.0	1-5	
	P	H		5960-686-9101		ELECTRON TUBE: MIL type 5979, Navy type BS-1			1		4.2	100.0	7-6	V102
	P	H		5960-296-1640		ELECTRON TUBE: Jan type 5980, Navy type BS-2			1		4.2	100.0	1-5	V101
	P	H		5960-188-6592		ELECTRON TUBE: MIL type 5962			1		8.0	100.0	1-6	V103
	P	H		5960-188-3524		ELECTRON TUBE: MIL type 3V4			1		4.2	100.0	1-6	V104
	PIH			5330-641-2381		GASKET: Admiral p/n 512AZ0			1		0.5	10.0		0108
	PIH			6665-387-7035		GASKET: Admiral p/n 512A21A			1		0.5	10.0		0114
	PIH			6665-387-8054		GASKET: Admiral p/n 512A23			1		0.5	10.0		0111
	PIH			6665-399-7312		GASKET: Admiral p/n 512A22			1		0.5	10.0		0112
	PIH			6665-351-6974		GUARD: Admiral p/n 515A139			1		0.5	3.0	7-6	H204
	PI0			5355-284-4571		KNOB: Rogan Bros. p/n RB-41			1		0.2	5.0	1-3	E106
	P	H		6240-179-1811		LAMP, GLOW: LM-54			1		4.2	50.0	1-4	E105
	P	H		6240-539-8959		LAMP, GLOW: GE p/n NE-76			1		4.2	50.0	1-5	E104
	P	H		6665-171-9567		METER, ROENTGEN RATE: Admiral p/n 559B1			1		4.2	5.0	1-5	M101

SOURCE CODE				FEDERAL STOCK NUMBER	DESIGNATION BY MODEL	DESCRIPTION	UNIT OF ISSUE	EXP	QTY IN UNIT	DIRECT SUPPORT	GENERAL SUPPORT	DEPOT	ILLUSTRATION	
A	B	C	D										FIGURE NO.	ITEM NO.
						AN/PDR-27G (Continued)								
P1	H			5310-392-8281		NUT, PACKING: Admiral p/n 520A15-1-3			2		0.5	20.0		H102, H201
P1	H			5330-187-3638		PACKING, PREFORMED: Admiral p/n 512A2-5			2		0.5	20.0	7-6	0201, 0202
P1	H			5330-291-5595		PACKING: Admiral p/n 512A2-2			1		0.5	10.0		0104
P1	H			5330-050-1211		PACKING, PREFORMED: Admiral p/n 512A2-11			1		0.5	10.0		0108
P1	H			5330-559-1291		PACKING, PREFORMED: Non-metallic 'O' Ring, 5/32 in ID x 9/32 in o/d x 1/16 in thk, MIL-P-5516, MIL type 6227-2			2		0.5	20.0		0105
P	H			5950-647-6439		REACTOR-TRANSFORMER: Admiral p/n 574B4-1			1		4.2	3.0	1-5	L101
P	H			6130-635-6195		RECTIFIER, METALLIC: International Rectifier p/n U45HP			1		4.2	5.0	1-5	CR101
P	H			5905-195-6761		RESISTOR, FIXED, COMPOSITION: MIL type RC20GF104J			3		4.2	15.0	7-3 1-5	R103, R113, R128
P	H			5905-192-0390		RESISTOR, FIXED, COMPOSITION: MIL type RC20GF105J			1		4.2	5.0	7-3	R109
P	H			5905-279-1866		RESISTOR, FIXED, COMPOSITION: MIL type RC20GF106K			2		4.2	10.0	1-5 1-6	R102, R114
P	H			5905-239-0583		RESISTOR, FIXED, COMPOSITION: MIL type RC20GF125K			1		4.2	5.0	1-5	R101
P	H			5905-192-0662		RESISTOR, FIXED, COMPOSITION: MIL type RC20GF184K			1		4.2	5.0	7-3	R105
P	H			5905-279-1875		RESISTOR, FIXED, COMPOSITION: MIL type RC20GF205J			1		4.2	5.0	1-5	R112
P	H			5905-295-3409		RESISTOR, FIXED, COMPOSITION: MIL type RC20GF224K			1		4.2	5.0	7-4	R116
P	H			5905-279-3498		RESISTOR, FIXED, COMPOSITION: MIL type RC20GF433J			1		4.2	5.0	1-6	R111
P	H			5905-295-3410		RESISTOR, FIXED, COMPOSITION: MIL type RC20GF473K			1		4.2	5.0	7-3	R107

SOURCE CODE				FEDERAL STOCK NUMBER	DESIGNATION BY MODEL	DESCRIPTION	UNIT OF ISSUE	EXP	QTY IN UNIT	DIRECT SUPPORT	GENERAL SUPPORT	DEPOT	ILLUSTRATION	
													FIGURE NO.	ITEM NO.
A	B	C	D											
				AN/PDR-27G (Continued)										
P	H			5905-232-2973		RESISTOR, VARIABLE: Centralab part Radiohm Model No. 1, 250,000 ohms, ±20%, 1/10 w			2		4.2	16.0	7-4 7-4	R104, R108
P	H			5905-232-2981		RESISTOR, VARIABLE: 1.5 meg, ±20%, 1/10 w, Centralab Radiohm Model No. 1			1		4.2	8.0	7-4	R106
P	H			5905-284-3444		RESISTOR, VARIABLE: 3 megohms, ±20%, 1/10 w, Centralab Radiohm Model No. 1			1		4.2	8.0	7-4	R110
Pl	H			6140-242-9167		RETAINER, BATTERY: Kelley-Koett p/n IDC-4789			1		0.5	3.0	3-2	A104
Pl	H			5305-206-5278		SCREW, CAPTIVE: Admiral p/n 501A5-1-52			10		1.4	100.0	7-3	H106
Pl	H			6665-663-8124		SHIELD, RADIAC DETECTOR: Admiral p/n GA-158-1			1		0.2	10.0	7-6	O206
P	H			5935-296-8430		SOCKET, ELECTRON TUBE: Eby type No. 8323			2		4.2	10.0	1-5 1-5	XV103, XV104
P	H			5935-201-3191		SOCKET, ELECTRON TUBE: Amphenol p/n 77-MIP-11TM			1		4.2	5.0		X201
Pl	H			6665-288-2272		SPROCKET, WHEEL: Boston Gear Wks p/n CBA-12MOD, Admiral p/n 530A4-1			2		0.5	4.0	7-3	O101
P	H			5930-548-4616		SWITCH, ROTARY: Oak p/n 42065-F3			1		4.2	7.0	7-3	S101
P	H			5930-646-4619		SWITCH, SENSITIVE: SPDT, MIL-S-6743, type MS250085-1			1		4.2	7.0	1-8	S102
Pl	H			5940-227-7182		TERMINAL BOARD: Cinch Mfg Co p/n 19F16780			1		0.5	5.0	1-5	E101
				RADIAC DETECTOR DT-106/PDR-27G										
P	H			5995-392-6836		CABLE ASSEMBLY: Admiral p/n 589B9			1		4.2	10.0	1-5	W201
Pl	H			5940-989-0041		CLIP, ELECTRICAL: Specialty Electronics p/n A17-C-1120			1		0.5	4.0	7-6	O207
El	H			6665-021-2069		COVER, RADIAC PROBE: Specialty Electronics p/n AML-5F-5			1		0.5	3.0		
P	H			5960-686-9101		ELECTRON TUBE: MIL type 5979, Navy type BS-1			1		6.0	100.0	7-6	V102

SOURCE CODE				FEDERAL STOCK NUMBER	DESIGNATION BY MODEL	DESCRIPTION	UNIT OF ISSUE	EXP	QTY IN UNIT	DIRECT SUPPORT	GENERAL SUPPORT	DEPOT	ILLUSTRATION	
													FIGURE NO.	ITEM NO.
A	B	C	D											
						AN/PDR-27G (Continued)								
	P1H			6665-351-6980		MOUNTING, ELECTRON TUBE: Admiral p/n 518B43			2		0.5	4.0	7-6	0208, 0209
	P1H			5330-559-1291		PACKING, PREFORMED: MIL type 6227-2			1		0.5	10.0		0203
	P1H			5330-187-3638		PACKING, PREFORMED: MIL type 6227-17			2		0.5	20.0	7-6	0201, 0202
	P1H			6665-351-6985		RING: Admiral p/n 257A87			1		0.5	2.0	7-6	0205
	P1H			6665-663-8124		SHIELD, RADIAC DETECTOR: Admiral p/n GA-158-1			1		0.5	10.0	7-6	0206
	P1H			5310-523-5908		WASHER, FLAT: Kelley-Koett p/n IDA-4781-1			1		0.5	10.0		H203

**By Order of the Secretary of the Army:**

**HAROLD K. JOHNSON,**  
*General, United States Army,*  
*Chief of Staff.*

**Official:**

**J. C. LAMBERT,**  
*Major General, United States Army,*  
*The Adjutant General.*

**Distribution:**

*Active Army:*

USASA (2)	Svc Colleges (2)
CNGB (1)	Br Svc Sch (2) except
CC-E (7)	USACMLCS (5)
Dir of Trans (1)	MFSS (5)
CofEngrs (1)	USAQMS (5)
TSG (1)	USA Ms & Ammo Cen and
CofSptS (1)	Sch (5)
USACDCEA (1)	WSMR (5)
USACDCCBRA (1)	WRAMC (5)
USACDCEA (1)	WBGH (5)
USACDCOA (1)	Instl (2) except
USACDCQMA (1)	Ft Monmouth (70)
USACDCTA (1)	Ft Gordon (10)
USACDCADA (1)	Ft Knox (12)
USACDCARMA (1)	Ft Hancock (4)
USACDCAVNA (1)	Ft Huachuca (10)
USACDCARTYA (1)	Ft Carson (25)
USACDCSWA (1)	Cp Desert Rock (5)
USACDCCEA, Ft Huachuca (1)	Army Pic Cen (2)
USACDCEC (10)	Army Dep (2) except
USAMC (5)	SAAD (30)
USCONARC (5)	TOAD (14)
ARADCOM (5)	FTWOAD (10)
ARADCOM Rgn (2)	LEAD (7)
OS Maj Comd (4) except	SHAD (3)
USASETAF (10)	NAAD (5)
USARHAW (10)	SVAD (5)
LOGCOMD (2)	CHAD (3)
USAMICOM (4)	ATAD (10)
USASMC (2)	LBAD (14)
USASCC (4)	Gen Dep (2)
MDW (1)	Sig Sec Gen Dep (5)
Armies (2) except	Sig Dep (12)
Third (10)	Sig Fld Maint Shops (2)
EUSA (10)	AMS (1)
Corps (2)	Edgewood Arsenal (8)
USAC (3)	USAERDAA (2)
Div (2) except	USAERDAW (12)
11th Air Aslt Div (3)	APG (5)
USATC (2)	DPG (5)
USMA (5)	USACRREL (2)

USA Engr R&D Lab (5)		8-500 (AA,	11-16
Units organized under following		AH, FB,	11-32
TOE's (2 copies each):		GC, GE,	11-57
1 - 5 8	6-405	GD, IA,	11-97
1-100	6-425	IB, ID,	11-98
1-101	6-426	IE, JA,	11-117
1-102	6-501	JB, KJ,	11-155
1-128	6-525	KL, KM,	11-157
1-145	6-526	KN, LA,	11-158
1-146	6-555	LB, MB,	11-358
1-147	6-556	MC, NA,	11-500 (AA-
1-148	6-565	NB, OA,	AC)
1-155	6-575	& RA)	11-587
1-156	6-576	8-510	11-592
1-157	6-700	8-520	11-597
1-158	6-701	8-551	12-52
1-165	6-702	8-563	12-56
1-166	6-705	8-565	17-4
1-167	6-706	8-566	17-15
3-7	6-715	8-567	17-16
3-47	6-716	8-571	17-26
3-77	6-725	8-581	17-32
3-217	6-726	8-590	17-35
3-267	6-727	8-650	17-36
3-500 (HA,	7-2	8-667	17-42
HB, HC,	7-4	9-12	17-46
IA, IB,	7-25	9-17	17-51
FA, FB,	7-26	9-22	17-52
GA, JA)	7-35	9-47	17-55
5-25	7-36	9-87	17-56
5-26	7-42	9-227	17-65
5-38	7-55	9-357	17-66
5-115	7-56	9-377	17-75
5-116	7-100	9-500 (AA,	17-76
5-127	7-102	AC, KA,	51-1
5-137	8-25	KC)	17-95
5-145	8-26	9-510	17-96
5-146	8-27	10-7	17-100
5-155	8-35	10-17	17-102
5-156	8-36	10-37	17-105
5-215	8-37	10-45	17-106
5-216	8-57	10-47	17-135
5-225	8-65	10-48	17-136
5-226	8-66	10-105	17-200
5-500 (MA)	8-67	10-107	17-201
5-600	8-112	10-349	17-205
5-601	8-122	10-445	17-206
6-100	8-127	10-447	29-1
6-101	8-128	10-467	29-5
6-300	8-137	10-500 (BH,	29-6
6-302	8-147	BI, BJ,	29-7
6-365	8-167	BK, BL,	29-11
6-366	8-187	GA, GC,	29-15
6-401	8-204	GF, GI)	29-17

29-21	55-302	29-311	44-85
29-25	57-4	30-600 (AA-	44-86
29-27	57-42	AE)	44-235
29-41	57-100	37-4	44-500 (GA)
29-45	57-102	37-42	44-535
29-46	29-65	37-100	44-536
29-51	29-75	37-102	44-544
29-56	29-77	39-51	44-545
51-2	29-85	39-401	44-546
55-111	29-86	41-2	44-547
55-121	29-87	41-500 (AA-	44-548
55-157	29-97	AC)	44-568
55-201	29-105	44-2	47-2
55-202	29-307	44-12	47-42

NG: State AG (3); units—same as Active Army except allowance is one copy to each unit.

**USAR:** None.

For explanation of abbreviations used, see AR 320-50.

Strip imprint





This fine document...

Was brought to you by me:



## [Liberated Manuals -- free army and government manuals](#)

Why do I do it? I am tired of sleazy CD-ROM sellers, who take publicly available information, slap “watermarks” and other junk on it, and sell it. Those masters of search engine manipulation make sure that their sites that sell free information, come up first in search engines. They did not create it... They did not even scan it... Why should they get your money? Why are not letting you give those free manuals to your friends?

I am setting this document FREE. This document was made by the US Government and is NOT protected by Copyright. Feel free to share, republish, sell and so on.

I am not asking you for donations, fees or handouts. If you can, please provide a link to [liberatedmanuals.com](http://liberatedmanuals.com), so that free manuals come up first in search engines:

<A HREF=<http://www.liberatedmanuals.com/>>Free Military and Government Manuals</A>

- Sincerely  
Igor Chudov  
<http://igor.chudov.com/>
- [Chicago Machinery Movers](#)