

August 1997

## BCD to Seven Segment Decoder/Driver

### Features

- TTL Compatible Input Logic Levels
- 25mA (Typ) Constant Current Segment Outputs
- Eliminates Need for Output Current Limiting Resistors
- Pin Compatible with Other Industry Standard Decoders
- Low Standby Power Dissipation . . . . . 18mW (Typ)

### Description

The CA3161E is a monolithic integrated circuit that performs the BCD to seven segment decoding function and features constant current segment drivers. When used with the CA3162E A/D Converter the CA3161E provides a complete digital readout system with a minimum number of external parts.

### Ordering Information

PART NUMBER	TEMP. RANGE (°C)	PACKAGE	PKG. NO.
CA3161E	0 to 70	16 Ld PDIP	E16.3

### Pinout

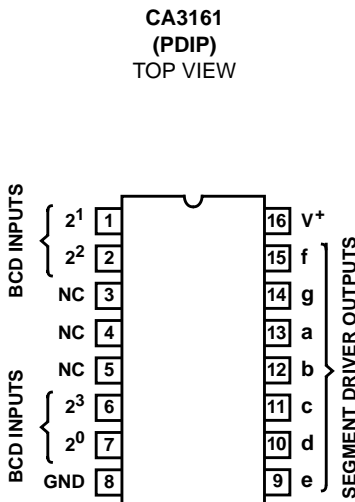

### Functional Block Diagram

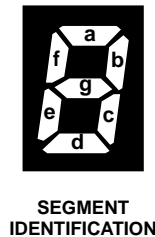
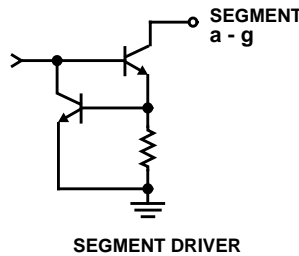
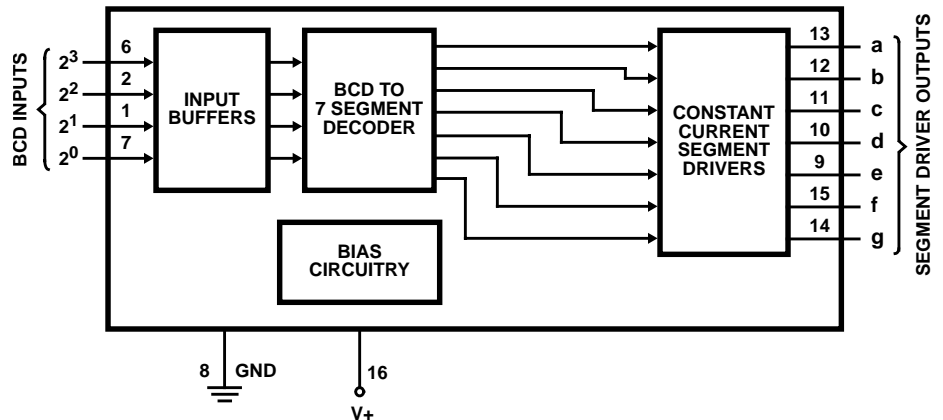

# CA3161

## Absolute Maximum Ratings

DC $V_{SUPPLY}$ (Between Terminals 1 and 10) . . . . .	+7.0V
Input Voltage (Terminals 1, 2, 6, 7) . . . . .	+5.5V
Output Voltage	
Output "Off" . . . . .	+7V
Output "On" (Note 1) . . . . .	+10V

## Thermal Information

Thermal Resistance (Typical, Note 2)	$\theta_{JA}$ ( $^{\circ}C/W$ )
PDIP Package . . . . .	100
Maximum Junction Temperature . . . . .	150 $^{\circ}C$
Maximum Storage Temperature Range . . . . .	-65 $^{\circ}C$ to 150 $^{\circ}C$
Maximum Lead Temperature (Soldering 10s) . . . . .	300 $^{\circ}C$

## Operating Conditions

Temperature Range . . . . . 0 $^{\circ}C$  to 75 $^{\circ}C$

*CAUTION: Stresses above those listed in "Absolute Maximum Ratings" may cause permanent damage to the device. This is a stress only rating and operation of the device at these or any other conditions above those indicated in the operational sections of this specification is not implied.*

### NOTES:

1. This is the maximum output voltage for any single output. The output voltage must be consistent with the maximum dissipation and derating curve for worst case conditions. Example: All segments "ON", 100% duty cycle.
2.  $\theta_{JA}$  is measured with the component mounted on an evaluation PC board in free air.

## Electrical Specifications $T_A = 25^{\circ}C$

PARAMETER	TEST CONDITIONS	MIN	TYP	MAX	UNITS
$V_{SUPPLY}$ Operating Range, $V^+$		4.5	5	5.5	V
Supply Current, $I^+$ (All Inputs High)		-	3.5	8	mA
Output Current Low ( $V_O = 2V$ )		18	25	32	mA
Output Current High ( $V_O = 5.5V$ )		-	-	250	$\mu A$
Input Voltage High (Logic "1" Level)		2	-	-	V
Input Voltage Low (Logic "0" Level)		-	-	0.8	V
Input Current High (Logic "1")	2V	-30	-	-	$\mu A$
Input Current Low (Logic "0")	0V	-40	-	-	$\mu A$
Propagation Delay Time,	$t_{PHL}$	-	2.6	-	$\mu s$
	$t_{PLH}$	-	1.4	-	$\mu s$

CA3161

TRUTH TABLE

BINARY STATE	INPUTS				OUTPUTS								DISPLAY
	2 <sup>3</sup>	2 <sup>2</sup>	2 <sup>1</sup>	2 <sup>0</sup>	a	b	c	d	e	f	g		
0	L	L	L	L	L	L	L	L	L	L	L	H	0
1	L	L	L	H	H	L	L	H	H	H	H	H	1
2	L	L	H	L	L	L	H	L	L	H	L	L	2
3	L	L	H	H	L	L	L	L	H	H	L	L	3
4	L	H	L	L	H	L	L	H	H	L	L	L	4
5	L	H	L	H	L	H	L	L	H	L	L	L	5
6	L	H	H	L	L	H	L	L	L	L	L	L	6
7	L	H	H	H	L	L	L	H	H	H	H	H	7
8	H	L	L	L	L	L	L	L	L	L	L	L	8
9	H	L	L	H	L	L	L	L	H	L	L	L	9
10	H	L	H	L	H	H	H	H	H	H	L	L	-
11	H	L	H	H	L	H	H	L	L	L	L	L	E
12	H	H	L	L	H	L	L	H	L	L	L	L	H
13	H	H	L	H	H	H	H	L	L	L	L	H	L
14	H	H	H	L	L	L	H	H	L	L	L	L	P
15	H	H	H	H	H	H	H	H	H	H	H	H	BLANK